

Service Manual

SYNTHESIZER SX-WSA1

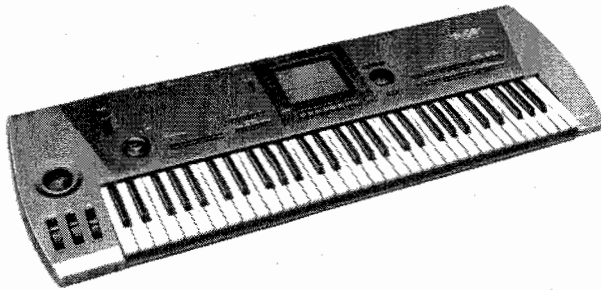

(M), (MC), (XM), (EN), (EH), (EF), (EZ), (EW), (EA),
(EP), (EK), (XL), (XR), (XS), (XD), (XT), (X), (XP)

AREAS

(M): U.S.A.	(EK): the United Kingdom
(MC): Canada	(XL): New Zealand
(XM): Mexico	(XR): Australia
(EN): Norway, Sweden, Denmark, Finland	(XS): Malaysia
(EH): Holland, Belgium	(XD): Saudi Arabia, Hong Kong, Kuwait
(EF): France, Italy	(XT): Taiwan
(EZ): Germany	(X): Thailand, Indonesia, Iran, U.A.E., Panama, Argentina, Peru, Brasil
(EW): Switzerland	(XP): Philippines
(EA): Austria	
(EP): Spain, Portugal, Greece, Singapore, South Africa	

⚠ WARNING

This service information is designed for experienced repair technicians only and is not designed for use by the general public. It does not contain warnings or cautions to advise non-technical individuals of potential dangers in attempting to service a product. Products powered by electricity should be serviced or repaired only by experienced professional technicians. Any attempt to service or repair the product or products dealt with in this service information by anyone else could result in serious injury or death.

■ Specifications

KEYBOARD	61 KEYS (WITH INITIAL/AFTER TOUCH)	
SOUND GENERATOR	ACOUSTIC MODELING SYNTHESIS	
MAXIMUM NUMBER OF NOTES PRODUCED SIMULTANEOUSLY	64 NOTES (32 PARTS MAX.)	
SOUND	PRESET (ROM): 256 SOUNDS +16 DRUM KITS, 128 COMBINATIONS USER: 256 SOUNDS + 4 DRUM KITS, 128 COMBINATIONS RE-MAP: 1, 2, 3 (GENERAL MIDI)	
BANK	USER 1, 2, ROM/EXT	
CONTROLLER	REALTIME CONTROLLER, REALTIME CREATOR, PITCH BEND WHEEL, MODULATION WHEEL 1, 2	
EDIT	SOUND	MODELING, TONE LAYER, PITCH, FILTER, AMPLITUDE, DIGITAL EFFECT, DSP EFFECT, CONTROLLER
	COMBINATION	INTERNAL SOUND, MIDI SOUND, CONFIGURE, MIXER, DSP EFFECT
DIGITAL EFFECT	12 TYPES	
DSP EFFECT	EFFECT 44 TYPES, REVERB 12 TYPES	
SEQUENCER	16 TRACKS RESOLUTION : 96 PULSES PER QUARTER-NOTE STORAGE CAPACITY : APPROX. 47000 NOTES (10 SONGS MAX.) INPUT MODES : REALTIME RECORD, STEP RECORD, MASTER RECORD FUNCTIONS : TRACK ASSIGN, EDIT, SONG SELECT/NAME, MEDLEY, AFTER TOUCH SET	
PART	INTERNAL SOUND, CONFIGURE, MIDI OUTPUT FILTER, MIXER, DSP EFFECT	
SYSTEM	TUNE & SCALE, OVERALL TOUCH SENSITIVITY, CONTROLLER ASSIGN, MIXER, DSP EFFECT, INITIAL, RE-MAP EDIT, SOUND/COMBI MANAGER, DRUMS MAP, MAIN OUT EQUALIZER	
MIDI	TOTAL MODE, REALTIME MESSAGE, INPUT & OUTPUT FILTER, PROGRAM CHANGE MIDI OUT, SYSEX BULK DUMP, GENERAL MIDI	
DISK	BUILT-IN 3.5 inch FLOPPY DISK DRIVE FOR 2HD (1.44 MB), 2DD (720 KB) DISK LOAD, DISK SAVE, MIDI FILE DIRECT PLAY, DISK FORMAT, LOAD SINGLE SOUND, LOAD SINGLE COMBINATION	
DISPLAY	LCD (320×240 DOTS) PAGE, CONTRAST, EXIT	
OTHERS	VOLUME, DATA ENTRY DIAL/KEYS, COMPARE	
TERMINALS	PHONES, MAIN OUT (R, L/MONO), SUB OUT (R, L/MONO), FOOT SW 1, 2, CONTROL PEDAL, MIDI (IN, OUT, THRU) ×2	

Technics

© 1995 Matsushita Electric Industrial CO., LTD. All rights reserved.
Unauthorized copying and distribution is a violation of law.

POWER REQUIREMENT	110 W, 100 W (CANADA), 80 W (U.S.A. AND MEXICO)
	AC120/220/240 V 50/60 Hz
	AC120 V 60 Hz (NORTH AMERICA AND MEXICO)
	AC230 V 50/60 Hz (NEW ZEALAND AND PHILIPPINES) AC230-240 V 50/60 Hz (EUROPE)
DIMENSIONS (W x H x D)	105.5 cm x 11.5 cm x 35.2 cm (41-17/32" x 4-17/32" x 13-27/32")
NET WEIGHT	13 kg (28.7 lbs.)
ACCESSORIES	AC CORD, DEMO DISK

•Specification are subject to change without notice for further improvement.

WARNING

To prevent the risk of fire, smoke, or electrical shock and to ensure safe operation, please be sure to follow the safety guidelines below.

1. At places where special caution is required, the necessary safety precautions are clearly labeled or printed, for example, on the cabinet, or on the part concerned. Please follow these safety precautions, and also those listed in the Owner's Manual.
2. Parts which have a  mark in the circuit diagram or in the parts list are essential for safety. When replacing these parts, be sure to use only the specified parts.
3. Use the specified types for internal wiring (double-insulated wiring, etc.).
4. When replacing parts on the AC primary side (power transformer, electric switch, electrical cord, noise-prevention condenser, etc.), wind the lead wire and secure it by soldering.
5. Do not let the wiring come into contact with heat-emitting devices (fuse resistor, radiator plate, etc.).
6. When replacing the wiring, make sure that it is not in contact with the unfinished or rough edge of a part.
7. When replacing the power cord (except for the plug-in type), tug it from various directions to confirm that it does not slip out of place.
8. Spacing
If soldering was done on the AC primary circuit, confirm that the interval between the soldered terminals or between the terminal and surrounding metallic parts is at least the minimum required (Between the primary circuit and the chassis: at least 6.5 mm; between primary circuit terminals: at least 4.0 mm; between primary circuit terminals and secondary circuit terminals: at least 6.5 mm.).

CONTENTS

INTRODUCTION

SAFETY PRECAUTION	I-2
INITIAL SETTING	I-3
TERMINALS	I-3
ARRANGEMENT OF CONTROL PANEL	I-4
PARTS LOCATION	I-6
KEYBOARD RANGES	I-6
DISASSEMBLY INSTRUCTIONS	I-7
MESUREMENTS AND ADJUSTMENTS	I-9
SYMPTOMS WHICH APPEAR	
TO BE SIGNS OF TROUBLE	I-10
ERROR DISPLAY	I-12
ABOUT THE SELF-DIAGNOSTIC FUNCTION	I-13
MIDI IMPLEMENTATION CHART	I-15
PRECAUTIONS BEFORE SERVICING	I-17

SCHEMATIC DIAGRAM

WIRING CONNECTION Diagram	II-1
BLOCK Diagram	II-3

MAIN MB1 MB2

MAIN/MB1/MB2 P. C. Diagram	II-7
MAIN MAIN (COMPONENT SIDE) P. C. Board	II-19
MAIN MB1 MB2 ACF MAIN (FOIL SIDE)/	
MB1/MB2/ACP P. C. Board	II-22
ACP ACP P. C. Diagram	II-25
INV INV CIRCUIT	II-26
CPC CPL CPR MOD1	
MOD2 BEND CNB CPC/CPL/CPR/	
MOD1/MOD2/BEND/CNB P. C. Board	II-27
CPC CPL CPR MOD1	
MOD2 BEND CNB CPC/CPL/CPR/	
MOD1/MOD2/BEND/CNB P. C. Diagram	II-30
MKB1 MKB2 MKB1/MKB2 Circuit	II-33

REPLACEMENT PARTS LIST

P. C. Board/WIRING	III-1
CABINET PARTS LOCATION	III-7
CABINET PARTS LIST	III-9
PACKING	III-10

SAFETY PRECAUTION (This "safety precaution" is for the U.S.A. only)

Safety Precaution

1. Before servicing, unplug the power cord to prevent an electric shock.
2. When replacing parts, use only the manufacturer's recommended components for safety.
3. Check the condition of the power cord. Replace if wear or damage is evident.
4. After servicing, be sure to restore the lead dress, insulation barriers, insulation papers, shields, etc..
5. Before returning the serviced equipment to the customer, be sure to make the following insulation resistance test to prevent the customer from being exposed to a shock hazard.

Insulation Resistance Test

1. Unplug the power cord and short the two prongs of the plug with a jumper wire.
2. Turn on the power switch.
3. Measure the resistance value with an ohmmeter between the jumpered AC plug and each exposed metal cabinet part, such as screw heads, connectors, control shafts, handle brackets, etc.. Measurements should range from 4 MΩ to infinity for all exposed parts.

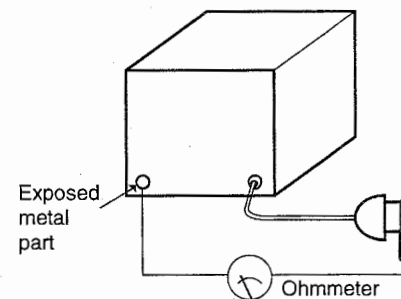

Resistance = 4MΩ to ∞

INITIAL SETTING

- The initial setting function is used to return to the original factory settings, and to reset the customer settings and misoperations.

1. Press the **POWER** button to turn off the instrument.
2. While pressing the three leftmost buttons in the **REALTIME CREATOR** section (1, 2, 3) at the same time, turn the **POWER** button on again.

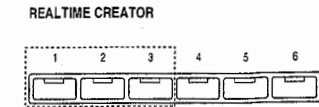
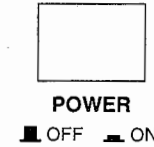

NOTE:

All stored data in the **SEQUENCER** and other setting are initialized with this operation.

TERMINALS

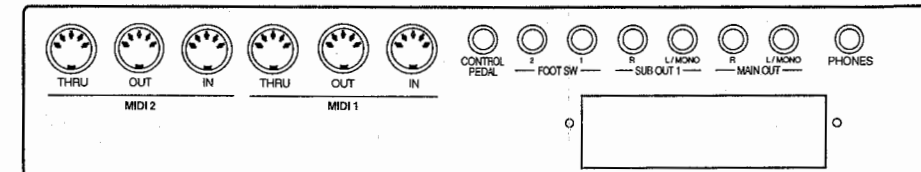

(on the rear panel)

MIDI (Musical Instrument Digital Interface)

MIDI is the standard specification that enables connection to equipment such as synthesizers and personal computers. Data transmission and reception are possible between the Technics Keyboard and other instrument provided with MIDI terminals.

IN : The terminal that receives data from external equipment.

OUT : The terminal that transmits data from this instrument to external equipment.

THRU: The terminal that transfers data from the **IN** terminal directly to other equipment.

- Use a 5-pin DIN cord (less than 15 m long) for these connections.

CONTROL PEDAL

The optional SZ-E2 Expression Pedal can be connected to this terminal to control various functions.

FOOT SW 1, 2

The optional SZ-P1 Foot Switch can be connected to this terminal to control various functions.

SUB OUT 1 (Output level 1.5 Vrms, 600 Ω)

This terminal is for sub output. To output monaural signals, connect the external equipment to the **L/MONO** terminal. (Do not connect the **R** terminal.)

MAIN OUT (Output level 1.5 Vrms, 600 Ω)

This terminal is for main output. To output monaural signals, connect the external equipment to the **L/MONO** terminal. (Do not connect the **R** terminal.)

PHONES (Use headphones with over 16 Ω impedance.)
For silent practice headphones may be used.

ARRANGEMENT OF CONTROL PANEL

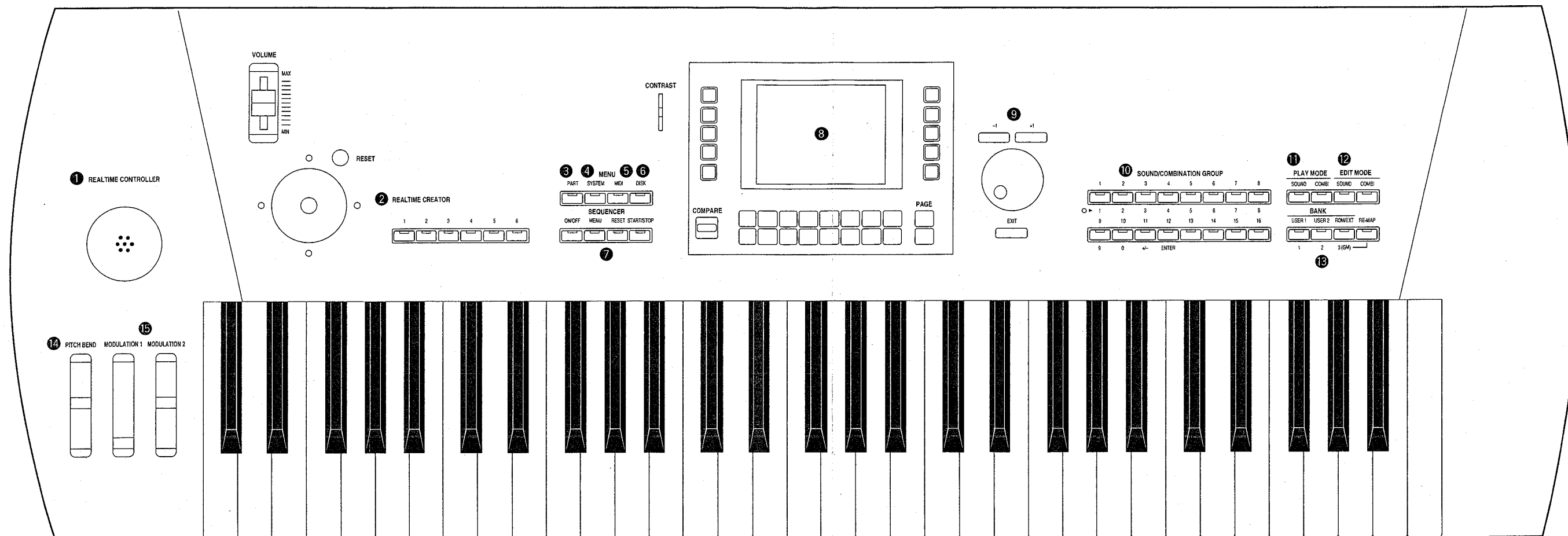

- 1 REALTIME CONTROLLER**
Modify the characteristics of the sounds during your performance. When you release your finger from this controller, it returns automatically to the neutral position.
- 2 REALTIME CREATOR**
Modify the characteristics of the sounds during your performance. You can return the sound to its original state by pressing the **RESET** button.
- 3 PART**
The settings for each part of this instrument can be adjusted to serve your personal preferences and requirements.
- 4 SYSTEM**
The settings for the whole instrument can be adjusted.
- 5 MIDI**
Select the various settings which are used for **MIDI** operation of this instrument.
- 6 DISK**
The Disk Drive enables you to store **SEQUENCER** data, sound data, etc. for future use.
- 7 SEQUENCER**
Record and play back performances.

- 8 Display**
The display shows the status of your performance and the various instrument settings at a glance.
- 9 Data entry controls**
Use these controls when setting a function and specifying a numerical value.
- 10 SOUND/COMBINATION GROUP**
Select the **SOUND** group or **COMBINATION** group used for your performance.
- 11 PLAY MODE**
Two modes are available for playing this instrument.
- 12 EDIT MODE**
Edit **SOUND** and **COMBINATION**.
- 13 BANK**
Select the bank of the **SOUND** or **COMBINATION** used for your performance.
- 14 PITCH BEND**
While pressing a key on the keyboard, move this wheel up and down to control the pitch.

- 15 MODULATION 1, 2**
While pressing a key on the keyboard, move these wheels to add effects. The **MODULATION 1** effect is off when the wheel is turned all the way down. The **MODULATION 2** effect is off when the wheel is set to the center.

PARTS LOCATION

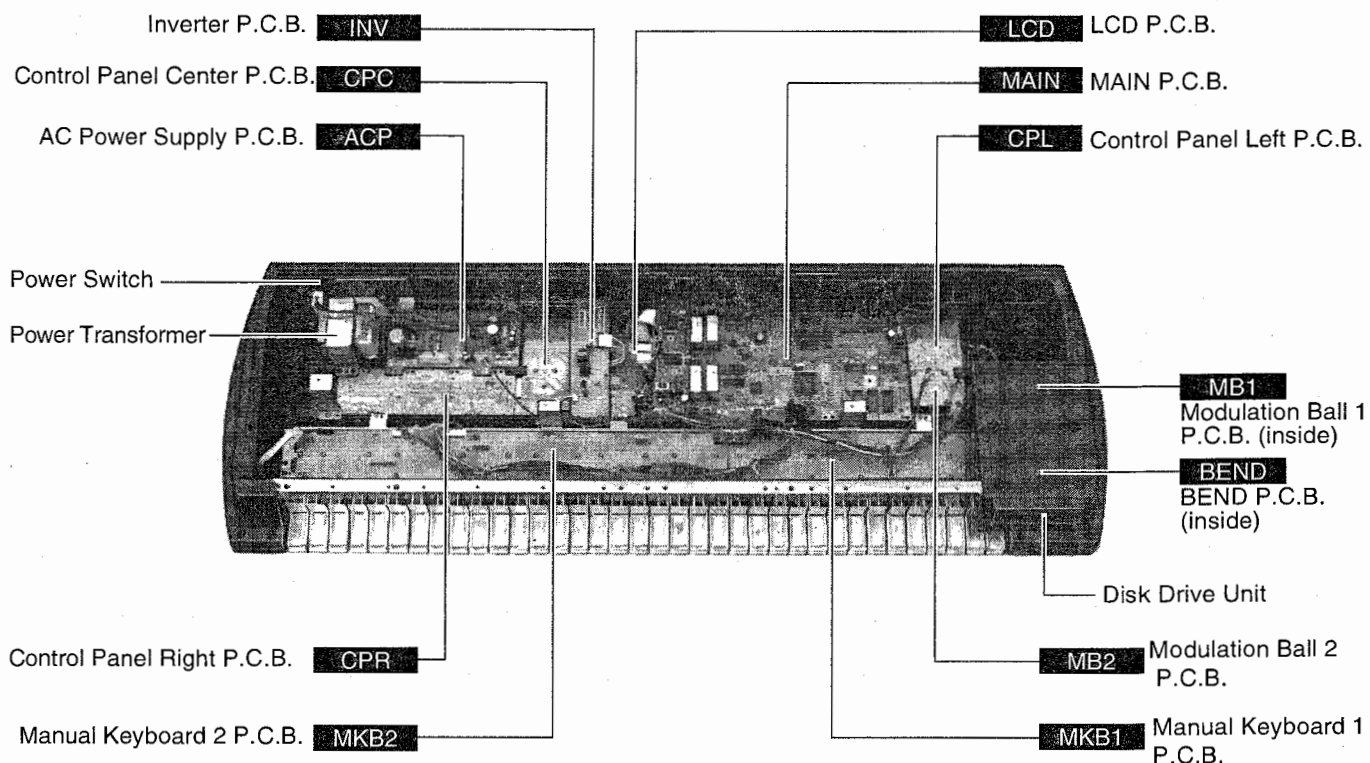

[Photo-1]

KEYBOARD RANGES

This keyboard features Touch Response, by which you control the volume by playing the keys harder or softer.

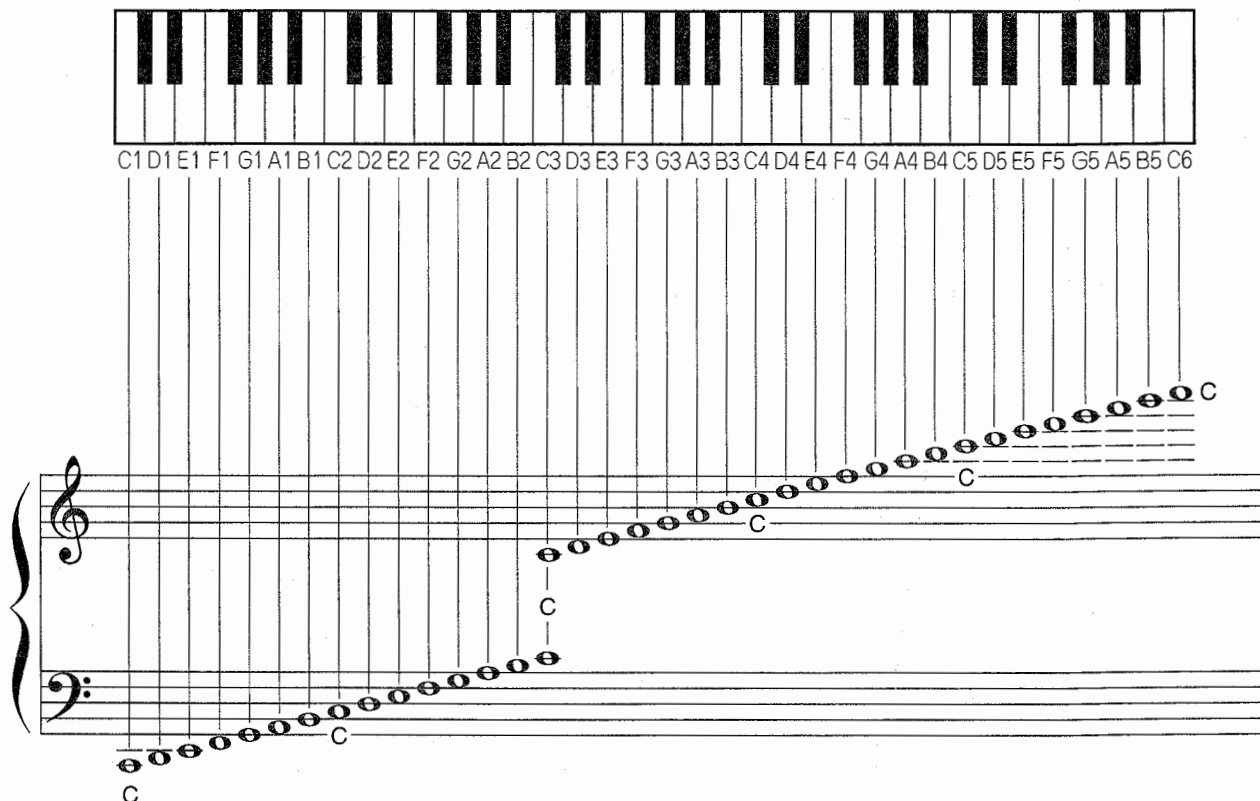

DISASSEMBLY INSTRUCTIONS

1 Opening the cabinet

1. Turn the keyboard cabinet upside down as shown in Fig. 1, and remove the bottom screws (A 19 pcs.).
2. Slide the bottom cabinet forward to remove it.

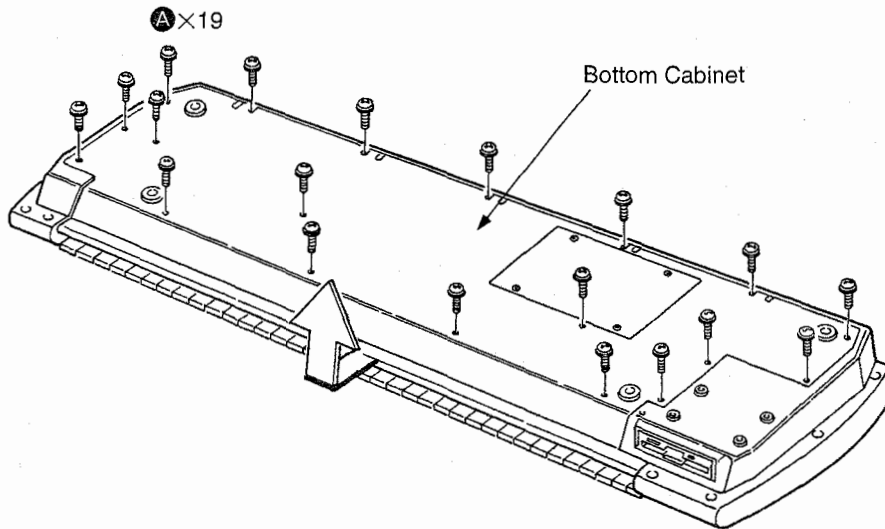

[Fig. 1]

2 Removing the keyboard unit

1. Open the cabinet (see step 1).
2. Remove the side cabinet holding screws (B 5 pcs.).
3. Remove the keyboard unit holding screws (C 8 pcs.).

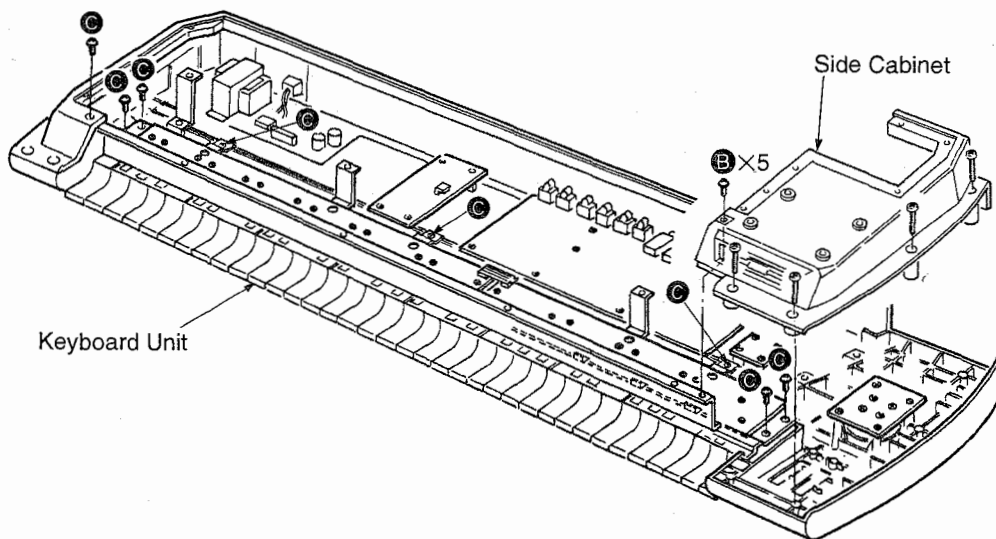

[Fig. 2]

3 Removing the printed circuit boards

- Remove the side cabinet (see step 2).

MAIN P.C.B.

- Remove the MAIN P.C.B. holding screws (D 3 pcs. and E 8 pcs.).

MB1 P.C.B.

- Remove the MB1 P.C.B. holding screws (F 4 pcs.).

MB2 P.C.B.

- Remove the MB2 P.C.B. holding screws (G 4 pcs.).

INV P.C.B.

- Remove the INV P.C.B. holding screws (H 3 pcs.).

BEND P.C.B.

- Remove the BEND P.C.B.s holding screws (I 6 pcs.).

ACP P.C.B.

- Remove the ACP P.C.B. holding screws (J 5 pcs.).

CPL, CPR, CPC, LCD P.C.B.

1. Remove the MAIN and INV P.C.B..
2. Remove the shield cover A holding screws (K 2 pcs.).
3. Remove the shield cover B holding screws (L 13 pcs.).
4. Remove the CPR P.C.B. holding screws (M 5 pcs.).
5. Remove the CPC and LCD P.C.B. holding screws (N 2 pcs., O 9 pcs. and P 3 pcs.).
6. Pull off the MAIN VOLUME knob.
7. Remove the CPL P.C.B. holding screws (Q 6 pcs.).

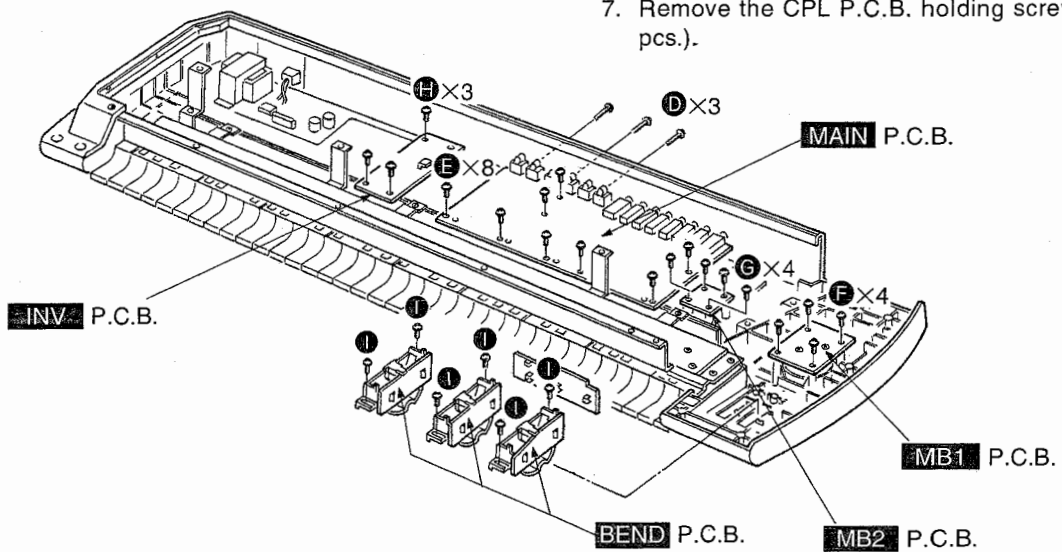

[Fig. 3]

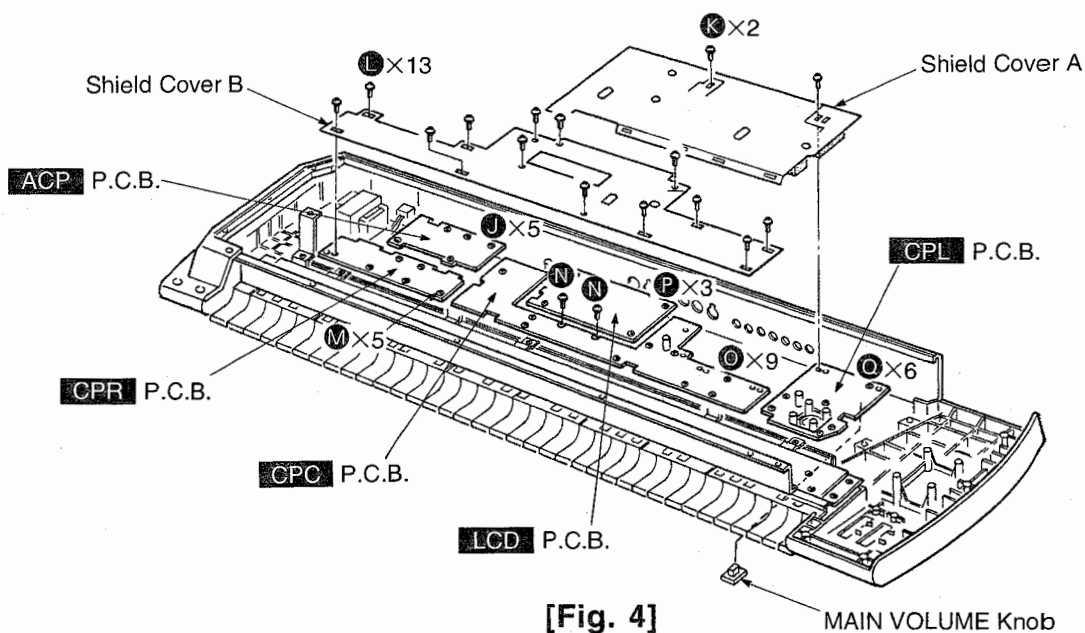

[Fig. 4]

4 Removing the digital disk recorder (DDR)

1. Remove the side cabinet (see step 2).
2. Remove the DDR mounting screws (R 4 pcs.).

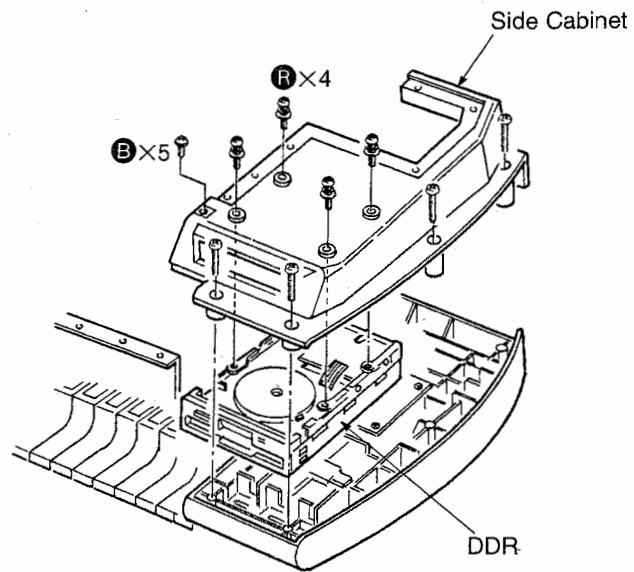

[Fig. 5]

5 Removing the keys (s)

1. Remove the keyboard unit (see step 2).
2. Press downward on the rear of the key (Fig. 6-1).
3. While pressing downward on the rear of the key, push the key forward and release it from the chassis (Fig. 6-2).
4. Lift the key and remove it from the chassis (Fig. 6-3).

NOTE:

To remove a black key, the white key to either side of it should be removed first.

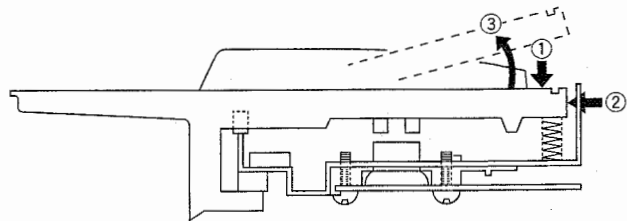

[Fig. 6]

MEASUREMENTS AND ADJUSTMENTS

ADJUSTMENT	MEASURING CONDITIONS	EQUIPMENT	ADJUSTMENT P.C.B.	ADJ. POINT	CONNECT METER TO	METER READING
AFTER TOUCH SENSOR Sensitivity	any position	Oscilloscope	MKB2 P.C.B.	VR1	CN5-3pin	5.0V
1. Press one of the any keys hardly and check the CN5-3pin voltage. The voltage will increase and became steady. 2. Adjust the voltage to 5.0V with VR1 at that time.						

SYMPTOMS WHICH APPEAR TO BE SIGNS OF TROUBLE

The following changes in performance may occur in the Technics Keyboard but do not indicate trouble.

	Phenomenon	Remedy
Sounds and effects	The buttons, keys, etc. malfunction.	<ul style="list-style-type: none"> • Turn off the POWER button once, then turn it on again. If this procedure is not successful, turn off the POWER button once. Then, while pressing the REALTIME CREATOR 1, 2 and 3 buttons at the same time (WSA1) or the REALTIME CREATOR 1-6 button and RESET button at the same time (WSA1R), turn the POWER button on again.
	No sound is produced when the keys are pressed.	<ul style="list-style-type: none"> • The VOLUME is at the minimum setting. Adjust the volume with the VOLUME control. • The volumes for the selected parts are set to the minimum levels. Set the volumes of the relevant parts to appropriate levels. • The local control for a part performed on the keyboard is set to OFF. Set the local control to ON.
	Only percussive instrument sounds are produced when the keyboard is played.	<ul style="list-style-type: none"> • The DRUM bank is selected.
	The volume is very low when the keyboard is played.	<ul style="list-style-type: none"> • The volume setting in the SEQUENCER contents is very low. Follow the INITIAL procedure to reset the settings.
	Some sounds cannot be selected.	<ul style="list-style-type: none"> • When the GENERAL MIDI status is set to on, The sounds which can be selected and operation which can be executed are limited. Turn the GENERAL MIDI status off to return the instrument to its normal operation.
	The sound you hear is different from the sound you selected.	<ul style="list-style-type: none"> • This sometimes occurs when you play back SEQUENCER data which was created on a different model, or when MIDI data is received from a connected instrument. Select the desired sounds again.
	You tried to store an edited sound, but it could not be stored.	<ul style="list-style-type: none"> • You cannot store a sound if MEMORY PROTECT is set to ON; set it to OFF.
SEQUENCER	Storage is not possible.	<ul style="list-style-type: none"> • The remaining memory capacity of the SEQUENCER is 0. Follow the SONG CLEAR or TRACK CLEAR procedure to erase the memory.
	Multi-track storage is not possible.	<ul style="list-style-type: none"> • The playback track has been selected, but the START/STOP button has not been pressed. To record one track while listening to another (playback) track, press the START/STOP button to begin playback.

Phenomenon		Remedy
Disk Drive	The Disk Drive produces a noise during recording or playback.	<ul style="list-style-type: none"> • This occurs when the Disk Drive is reading a disk. It does not indicate a problem.
	When the procedure to load from a disk is performed, the contents of the keyboard memory are erased.	<ul style="list-style-type: none"> • When performing the load operation from a disk, the keyboard memory changes to that of the data loaded from the disk. If you wish to preserve a song which is stored in the keyboard memory, save it on a disk before performing the load procedure.
Other	Noise from a radio or TV can be heard.	<ul style="list-style-type: none"> • This sometimes occurs when electrical equipment such as a radio or TV is used near the instrument. Try moving such electrical equipment further away from the instrument. • The sound may be coming from a nearby broadcast station or amateur radio station. If the sound is bothersome, consult your dealer or service center.
	The cabinet becomes warm during use.	<ul style="list-style-type: none"> • This instrument has a built-in power source that heats the cabinet to some degree. This is not an indication of trouble.

ERROR DISPLAY

No.	Contents
00	The data on the disk that you are using is for a different product.
01	An error has occurred while the disk was loading. Please try again!
02	There is no disk in the Disk Drive.
03	The file that you tried to load is empty.
05	An error has occurred while the disk was saving. Please try again!
06	The disk that you are using is write protected. Please remove the write protection and try again.
07	The disk that you are using is full. Please use another disk.
08	An error has occurred while the disk was formatting. The disk that you are using may be faulty. Please try formatting another disk.
10	The data is already copy protected.
20	A problem has occurred with your SEQUENCER Data. This might be due to a damaged or faulty disk.
21	Memory full
28	This song is too long to be saved as a MIDI file.
29	The MIDI file that you have tried to load exceeds the memory capacity of the WSA and cannot be played. The SEQUENCER memory has been cleared.
40	The Identification (ID) code of the system exclusive data received by the WSA is for a different product.
41	An error has occurred during system exclusive data reception. The data from the transmitting device may be incomplete. Please try again.
42	An error has occurred during system exclusive transmission. The data has not been received correctly. Please try again.
58	The song that you have tried to load exceeds the WSA's available memory and cannot be loaded. The selected song memory has been cleared. Please clear existing songs in the instrument's memory using SONG CLEAR to make more memory available, and try again.

ABOUT THE SELF-DIAGNOSTIC FUNCTION

This model has some self-diagnostic capabilities. When set to the self-diagnostic mode, operation of various components can be verified by following the procedures in the chart below.

No.	PCB	TEST MODE	Procedure																																																																			
1	MAIN	RAM (IC14, 15), ROM (IC11, 12) check	1. Connect the CHECKING DEVICE (refer to page I-14) to CN4 on the MAIN P.C.B., and turn on the CHECKING DEVICE switch. 2. Turn on the power switch.																																																																			
		<p>When the power switch is turned on, the LED of the CHECKING DEVICE flashes 8 times. The first 4 flashes are for the RAM check, and the latter 4 flashes are for the ROM check. The order of the LED flashes corresponds to the respective IC numbers as shown below. If an IC is defective, the corresponding flash time is longer.</p> <p>Examples</p> <table border="0" data-bbox="272 548 1431 927"> <tr> <td></td> <td></td> <td colspan="4" style="text-align: center;">RAM</td> <td colspan="4" style="text-align: center;">ROM</td> </tr> <tr> <td></td> <td></td> <td style="text-align: center;">1</td><td style="text-align: center;">2</td><td style="text-align: center;">3</td><td style="text-align: center;">4</td> <td style="text-align: center;">1</td><td style="text-align: center;">2</td><td style="text-align: center;">3</td><td style="text-align: center;">4</td> </tr> <tr> <td style="vertical-align: top;">1. RAM OK, ROM OK</td> <td style="text-align: center;">→</td> <td style="text-align: center;">●</td><td style="text-align: center;">●</td><td style="text-align: center;">●</td><td style="text-align: center;">●</td> <td style="text-align: center;">●</td><td style="text-align: center;">●</td><td style="text-align: center;">●</td><td style="text-align: center;">●</td> </tr> <tr> <td style="vertical-align: top;">2. RAM OK, ROM (IC11, 12) defective</td> <td style="text-align: center;">→</td> <td style="text-align: center;">●</td><td style="text-align: center;">●</td><td style="text-align: center;">●</td><td style="text-align: center;">●</td> <td style="text-align: center;">—</td><td style="text-align: center;">●</td><td style="text-align: center;">●</td><td style="text-align: center;">●</td> </tr> <tr> <td style="vertical-align: top;">3. RAM (IC14) defective, ROM OK</td> <td style="text-align: center;">→</td> <td style="text-align: center;">—</td><td style="text-align: center;">●</td><td style="text-align: center;">●</td><td style="text-align: center;">●</td> <td style="text-align: center;">●</td><td style="text-align: center;">●</td><td style="text-align: center;">●</td><td style="text-align: center;">●</td> </tr> <tr> <td></td> <td></td> <td style="text-align: center;">↑</td><td style="text-align: center;">↑</td> <td colspan="2"></td> <td style="text-align: center;">↑</td> <td colspan="3"></td> </tr> <tr> <td></td> <td></td> <td style="text-align: center;">IC14</td><td style="text-align: center;">IC15</td> <td colspan="2"></td> <td style="text-align: center;">IC11</td><td colspan="3" style="text-align: center;">IC12</td> </tr> </table> <p>NOTE : ● indicates short flash time — indicates long flash time</p>			RAM				ROM						1	2	3	4	1	2	3	4	1. RAM OK, ROM OK	→	●	●	●	●	●	●	●	●	2. RAM OK, ROM (IC11, 12) defective	→	●	●	●	●	—	●	●	●	3. RAM (IC14) defective, ROM OK	→	—	●	●	●	●	●	●	●			↑	↑			↑						IC14	IC15			IC11	IC12
		RAM				ROM																																																																
		1	2	3	4	1	2	3	4																																																													
1. RAM OK, ROM OK	→	●	●	●	●	●	●	●	●																																																													
2. RAM OK, ROM (IC11, 12) defective	→	●	●	●	●	—	●	●	●																																																													
3. RAM (IC14) defective, ROM OK	→	—	●	●	●	●	●	●	●																																																													
		↑	↑			↑																																																																
		IC14	IC15			IC11	IC12																																																															
2	CPC	CPU (IC1) check	1. Connect the CHECKING DEVICE to CN4 on the MAIN P.C.B. (The CHECKING DEVICE switch should be off). 2. Press and hold the two D keys shown below, and then turn on the power switch.																																																																			
		<p>When the power switch is turned on, the LED of the CHECKING DEVICE flashes 4 times. The order of the LED flashes corresponds to the CPU (IC) on the respective P.C.B.s as shown below. If an IC is defective, the corresponding flash time is longer.</p> <table border="0" data-bbox="272 1377 1431 1666"> <tr> <td></td> <td></td> <td style="text-align: center;">1</td><td style="text-align: center;">2</td><td style="text-align: center;">3</td><td style="text-align: center;">4</td> </tr> <tr> <td style="vertical-align: top;">1. CPU (IC1) OK</td> <td style="text-align: center;">→</td> <td style="text-align: center;">—</td><td style="text-align: center;">—</td><td style="text-align: center;">—</td><td style="text-align: center;">●</td> </tr> <tr> <td style="vertical-align: top;">2. CPU (IC1) defective</td> <td style="text-align: center;">→</td> <td style="text-align: center;">—</td><td style="text-align: center;">—</td><td style="text-align: center;">—</td><td style="text-align: center;">—</td> </tr> <tr> <td></td> <td></td> <td colspan="4"></td> <td style="text-align: center;">↑</td> </tr> <tr> <td></td> <td></td> <td colspan="4"></td> <td style="text-align: center;">CPU (IC1)</td> </tr> </table> <p>NOTE : ● indicates short flash time — indicates long flash time</p>			1	2	3	4	1. CPU (IC1) OK	→	—	—	—	●	2. CPU (IC1) defective	→	—	—	—	—							↑							CPU (IC1)																																				
		1	2	3	4																																																																	
1. CPU (IC1) OK	→	—	—	—	●																																																																	
2. CPU (IC1) defective	→	—	—	—	—																																																																	
						↑																																																																
						CPU (IC1)																																																																
3	CPL CPC CPR	Control Panel LED check	Press and hold the two F keys shown below, and then turn on the power switch.																																																																			
		Press the buttons on the control panel and confirm that the corresponding LEDs light.																																																																				

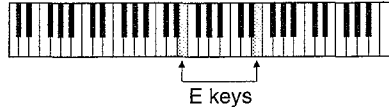
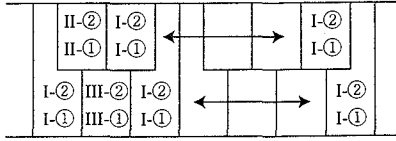
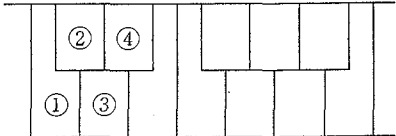
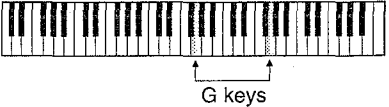
No.	PCB	TEST MODE	Procedure
4	MAIN	Wave ROM check MAIN: IC43-45, 47-49 Generator IC Outsel check	Press and hold the two E keys shown below, and then turn on the power switch. 
		When set to the self-diagnostic mode, the Wave ROM outputs a sine wave. The Wave ROMs correspond to the keyboard keys as shown in the diagram to the right. When a key is pressed, the corresponding sine wave sound is produced. If no sound is produced, or if the sound is distorted, the Wave ROM corresponding to that key is defective.	<ul style="list-style-type: none"> The key number indicates the Wave ROM number. (I-①: IC43, I-②: IC47, II-①: IC44, II-②: IC48, III-①: IC45, III-②: IC49)  <ul style="list-style-type: none"> Generator IC Outsel check (①: MAIN OUT, ②: SUB OUT 1, ③: SUB OUT 2, ④: SUB OUT 3) 
5	LCD	LCD check	Press and hold the two G keys shown below, and then turn on the power switch. 
		When set to the self-diagnostic mode, the test pattern is shown on the display. Monitor the display to confirm that the characters appear correctly.	

■ Connection between serving CHECKING DEVICE and MAIN P.C.B.

NOTE: The order of the MAIN P.C.B. terminals differs from previous models.

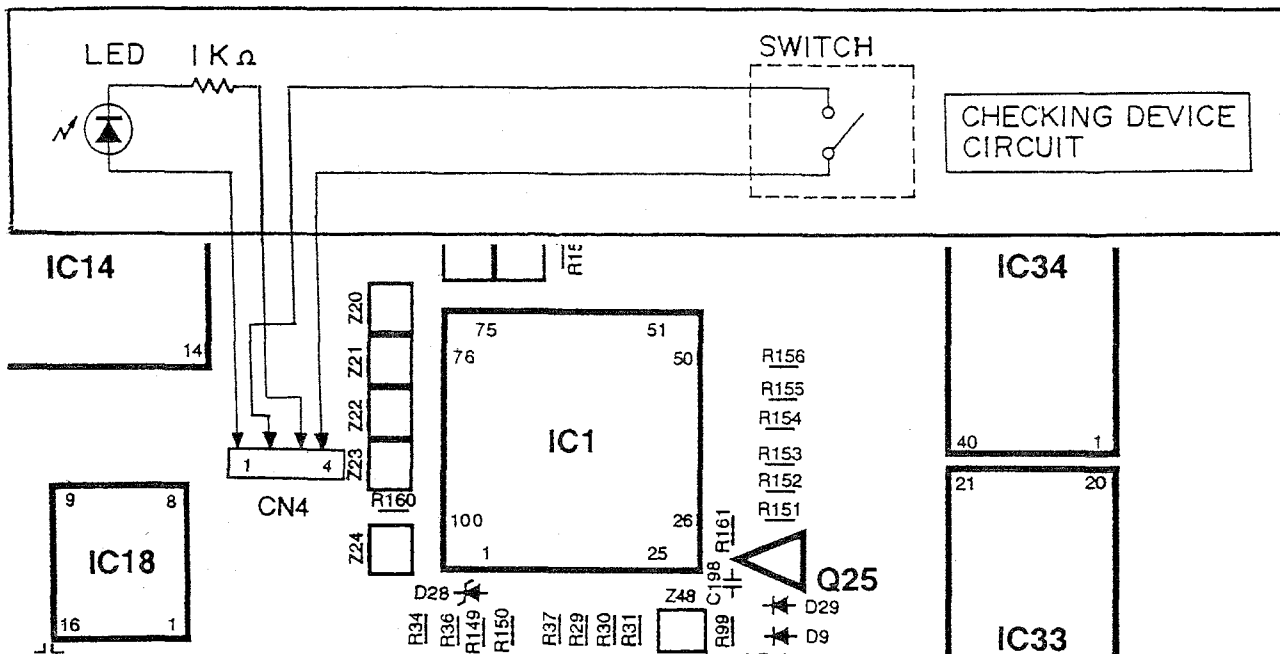

MIDI IMPLEMENTATION CHART

Synthesizer [SX-WSA1]

(Transmitted)

Function		PART1 ~ 32	Remarks
Basic Channel	Default	1-1~2-16	MIDI1: 1-1~1-16, MIDI2: 2-1~2-16
	Changed	1-1~2-16	Single Channel: 1-1~1-16
MODE	Default	3	OMNI OFF, POLY MODE
	Messages	×	
	Altered	-	
Note Number	True Voice	0-127 -	
Velocity	Note ON	○	
	Note OFF	×	
After Touch	Key's	×	
	Ch's	○×*	
Pitch Bend		○×*	
Control Change	0,32	○×*	bank select MSB, LSB
	1,2		modulation 1, 2 default
	4		control pedal default
	6,38		data entry MSB, LSB
	7		volume
	10		panpot
	11		expression
	16,17		realtime creator X, Y default
	18,19		realtime controller X, Y default
	64		hold1
	81		realtime creator SW1-6
	91		reverb depth
	93,94		effect1, 2 depth
	100,101		RPN LSB, MSB
120	all sound off		
121	reset all controllers		
Prog Change	True#	○×*	
		-	
System Exclusive		○×*	
System Common	Song Pos	○×*	MIDI 1 only
	Song Sel	○×*	MIDI 1 only
	Tune	×	
System Real time	Clock	○	
	Commands	○×*	
Aux Messages	Local ON/OFF	×	
	ALL notes OFF	×	
	Active Sense	○	
	Reset	×	
Notes	○×*.....Whether or not the data for each of these items is transmitted can be set.		

Mode1: OMNI ON,POLY
Mode3: OMNI OFF,POLY

Mode2: OMNI ON,MONO
Mode4: OMNI OFF,MONO

○:Yes
×:No

Function		PART1 ~ 32	Remarks
Basic Channel	Default	1-1~2-16	MIDI1: 1-1~1-16, MIDI2: 2-1~2-16
	Changed	1-1~2-16	Single Channel: 1-1~1-16
MODE	Default	3	OMNI OFF, POLY MODE
	Messages	×	
	Altered	-	
Note Number	True Voice	0-127	Normal Sound:12-120, Drum Sound:0-127
		12-120/0-127	
Velocity	Note ON	○	
	Note OFF	×	
After Touch	Key's	×	
	Ch's	○×*	
Pitch Bend		○×*	
Control Change	0,32	○×*	bank select MSB, LSB modulation 1, 2 default control pedal default data entry MSB, LSB volume panpot expression realtime creator X, Y default realtime controller X, Y default hold1 realtime creator SW1-6 reverb depth effect1, 2 depth RPN LSB, MSB all sound off reset all controllers
	1,2		
	4		
	6,38		
	7		
	10		
	11		
	16,17		
	18,19		
	64		
	81		
	91		
	93,94		
	100,101		
	120		
121			
Prog Change	True#	○×*	
		0-127	
System Exclusive		○×*	
System Common	Song Pos	○×*	MIDI 1 only
	Song Sel	○×*	MIDI 1 only
	Tune	×	
System Real time	Clock	○×*	
	Commands	○×*	
Aux Messages	Local ON/OFF	×	
	ALL notes OFF	○	
	Active Sense	○	
	Reset	×	
Notes	○×*.....Whether or not the data for each of these items is recognized can be set.		

Mode1: OMNI ON,POLY Mode2: OMNI ON,MONO ○:Yes
 Mode3: OMNI OFF,POLY Mode4: OMNI OFF,MONO ×:No

PRECAUTIONS BEFORE SERVICING

■ Precautions for measuring of the output waveforms.

- The waveform was measured with a "National Digital Storage Oscilloscope VP-5730A". Therefore the waveforms of musical tone signals shown may differ somewhat due to the difference in the timing of triggering.
- Since the 1/10 test probe is used, the indicated voltage value on the bottom part of each waveform photo is 1/10 of the actual value (e.g. 0.2 V/cm should be 2.0 V/cm).
- To measure the waveforms, first set this unit to the self-diagnostic mode (refer to page I-14, No. 4). The Wave ROM output will then be output as a sine wave to facilitate the servicing check.

■ Important safety notice:

Components identified by a Δ mark have special characteristics important for safety. When replacing any of these components, use only manufacturer's specified parts.

■ Symbolic Marks

The symbolic marks for resistors and capacitors which used in this circuits are classified as following TABLE-1 and TABLE-2.

1. RESISTORS

- Resistors without symbolic mark are FIXED CARBON FILM RESISTORS (ERD-type).
- All resistors are 1/4 WATT, $\pm 5\%$ TOLERANCE unless otherwise designated in schematic diagrams.

(TABLE-1)

SYMBOL	SPECIFICATION	SYMBOL	SPECIFICATION
Ⓣ	Fixed Carbon Film Resistors "FLAME-PROOF" (ERD-F-type)	Ⓣ	Fixed Metal Film Resistors "FLAME-PROOF" (ERX-type)
Ⓣ	Fixed Wire Wound Resistors "FLAME-PROOF" (ERF-type)	Ⓣ	Fuse Type Fixed Metal Oxide Film Resistors "FLAME-PROOF" (ERQ-type)
Ⓣ	Fixed Metal Oxide Film Resistors "FLAME-PROOF" (ERG-type)	Ⓣ	Fuse Type Fixed Carbon File Resistors "FLAME-PROOF" (ERD2FC-type)
Ⓣ	Fixed Metal Film Resistors (Precision and High Stability) (ERO-type)		

2. CAPACITORS

- Capacitors without symbolic mark are POLYESTER CAPACITORS. (ECQM-type, ECQG-type, $\pm 10\%$ Tolerance)
- Polarized capacitors without symbolic mark are Aluminum Electrolytic Capapcitors. (ECEA-type, $\pm 20\%$ Tolerance)

(TABLE-2)

SYMBOL	SPECIFICATION	TYPE
Ⓝ	Non-Polarized Electrolytic Capacitors	ECEA_KN_type
Ⓝ	Non-Polarized Electrolytic (for Network system)	ECEA_Y_type
Ⓝ	Tantalum Solid Electrolytic Capacitors	ECS_type
Ⓝ	Metalized Plastic Film Capacitors (TF Series)	ECQV_type
○	Temperature Compensating Ceramic Capacitors	ECC_type
	High-Dielectric Constant Ceramic Capacitors	ECK_type ECR_type
	Axial Lead Ceramic Capacitors	ECB_type
	Metalized Polyester Film Capacitors for Across the Line	ECQ_EW_type
	Aluminum Electrolytic Capacitors for Smoothing Circuit	ECES_type
	Multilayer Ceramic Chip Capacitors	ECUV_type

WIRING CONNECTION Diagram

WIRING CONNECTION Diagram

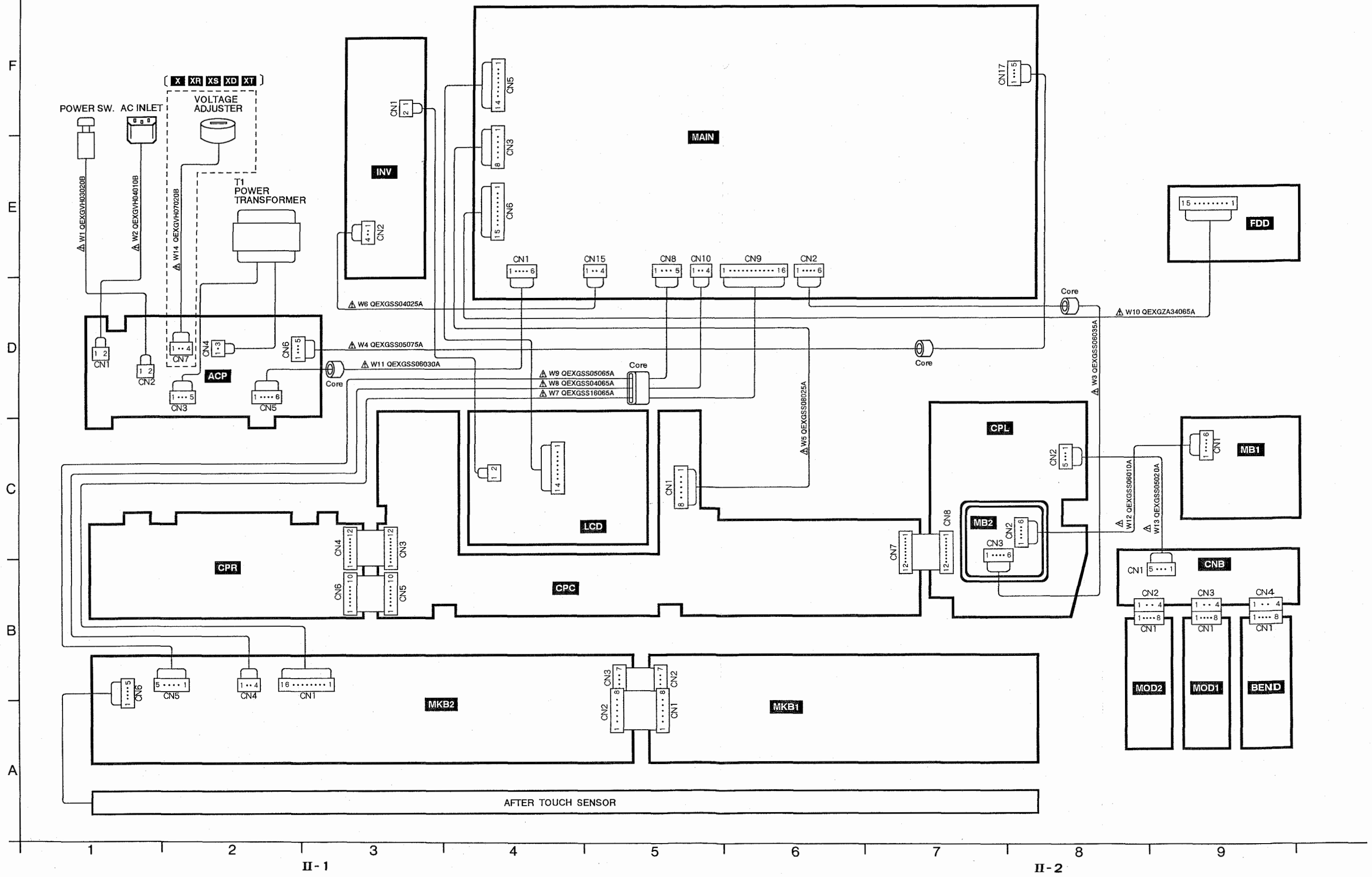

BLOCK Diagram

⇒ Tone Signal → Control Signal

F
E
D
C
B
A

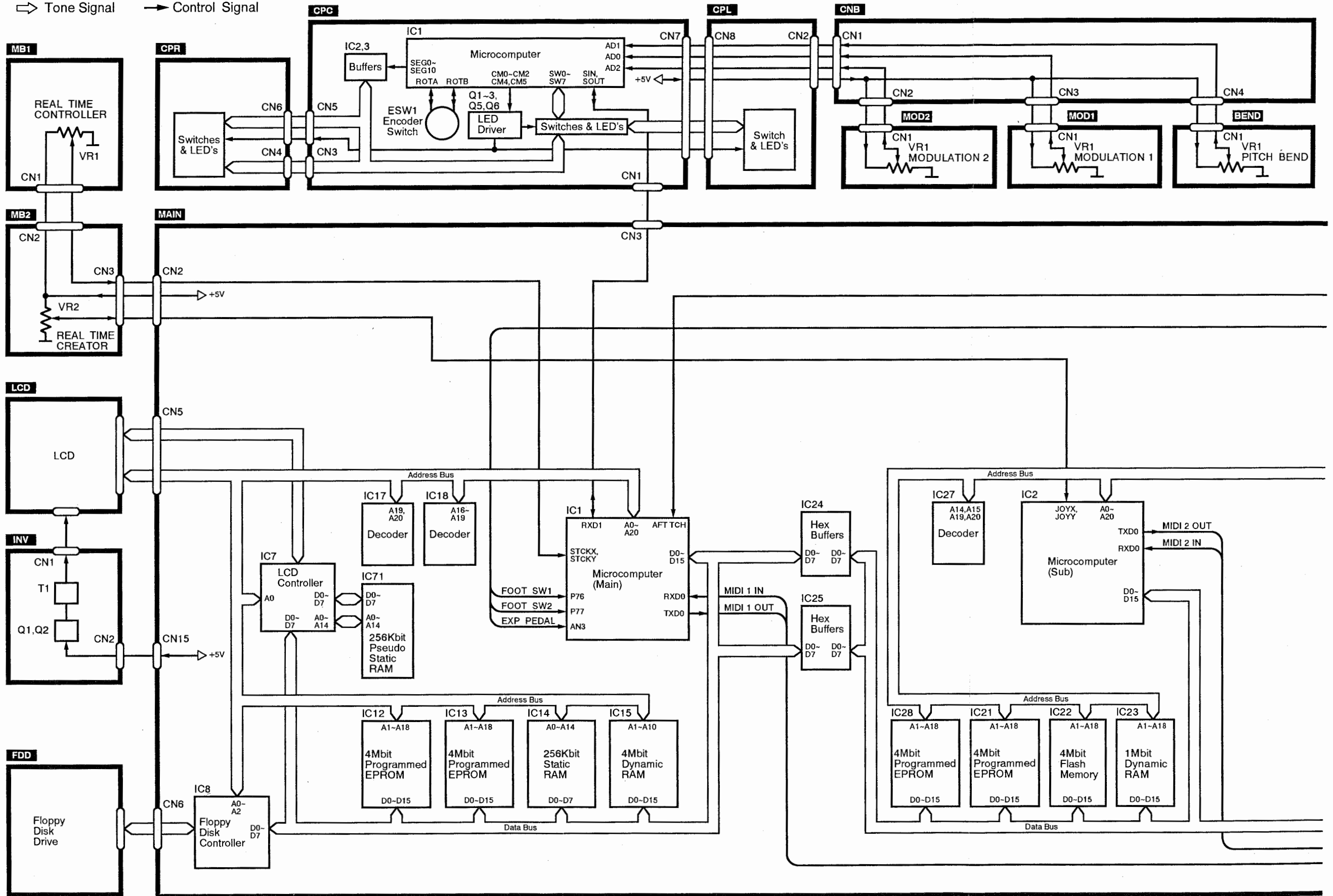

II-3

II-4

1 2 3 4 5 6 7 8 9 10

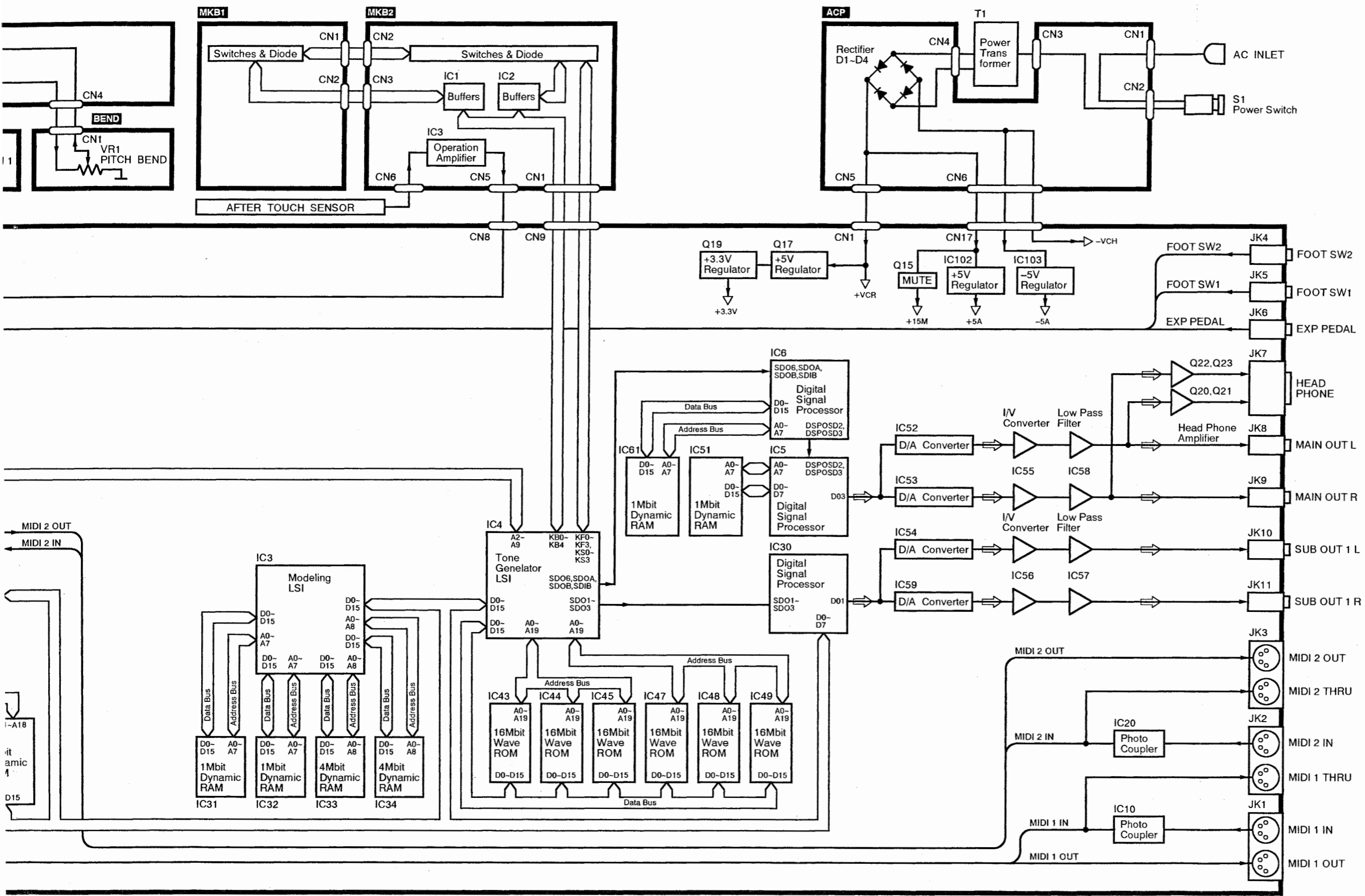

MAIN (A)/MB1/MB2 P.C. Diagram

F
E
D
C
B
A

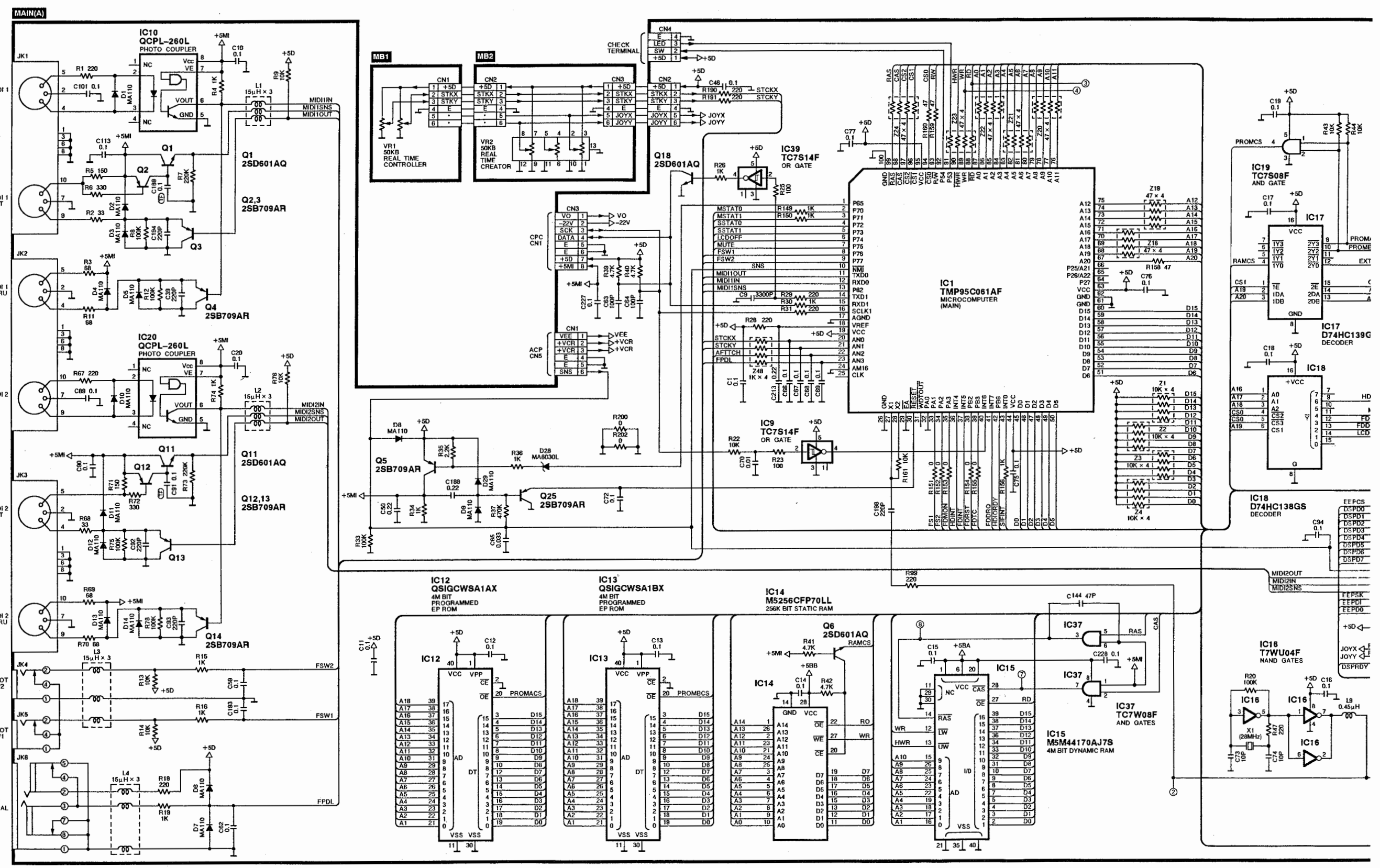

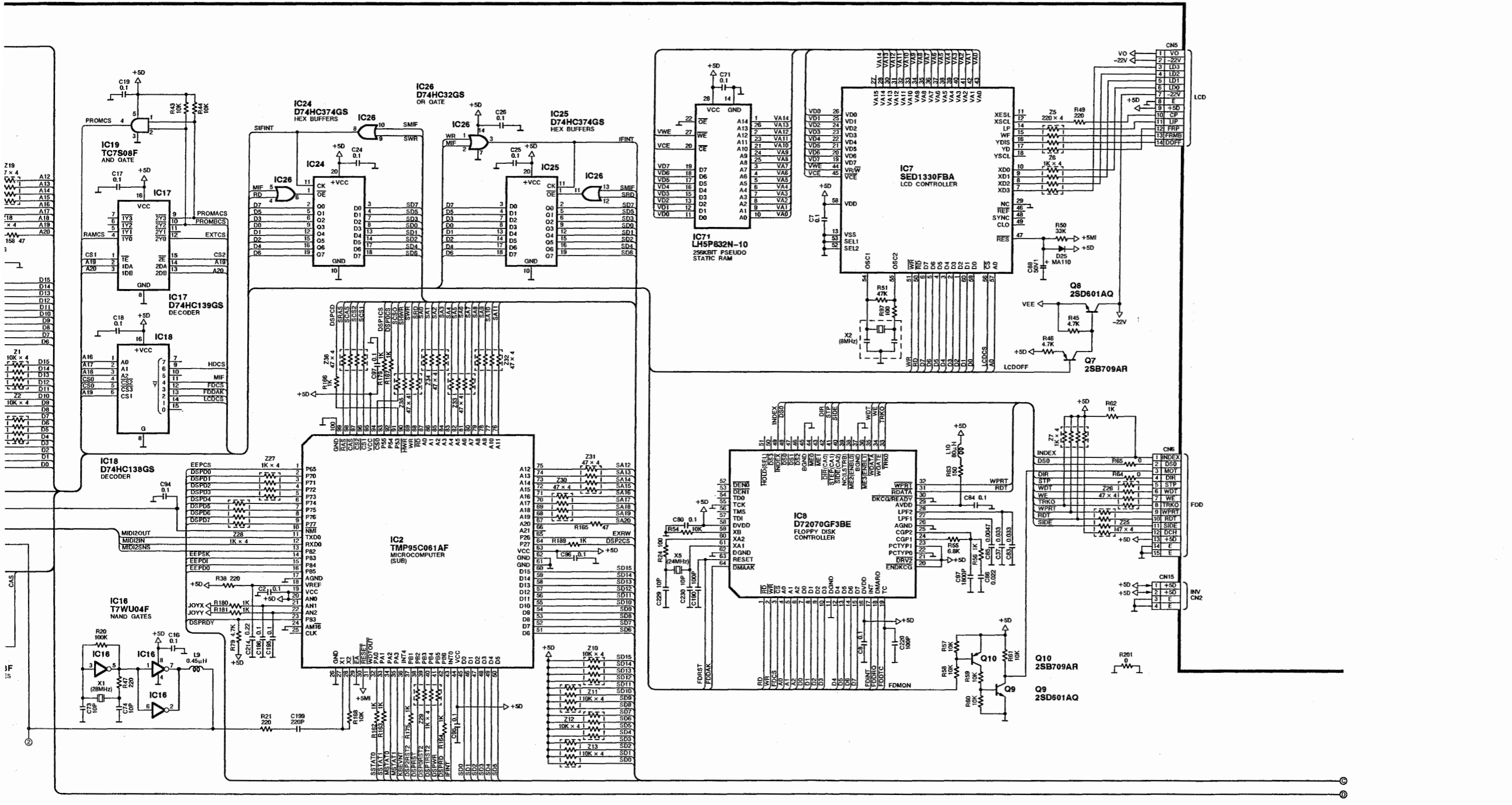

MAIN (B) P.C. Diagram

F

E

D

C

B

A

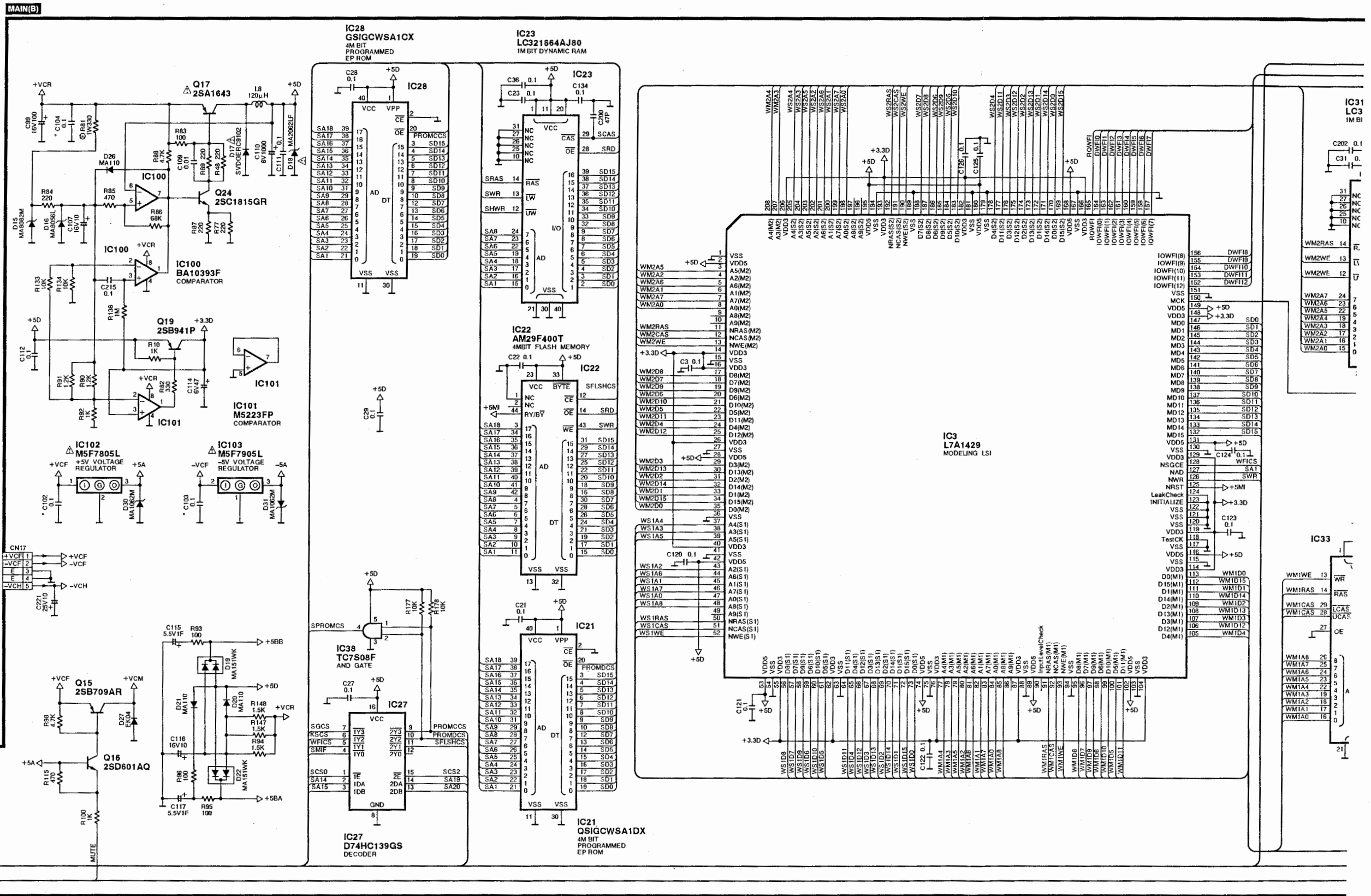

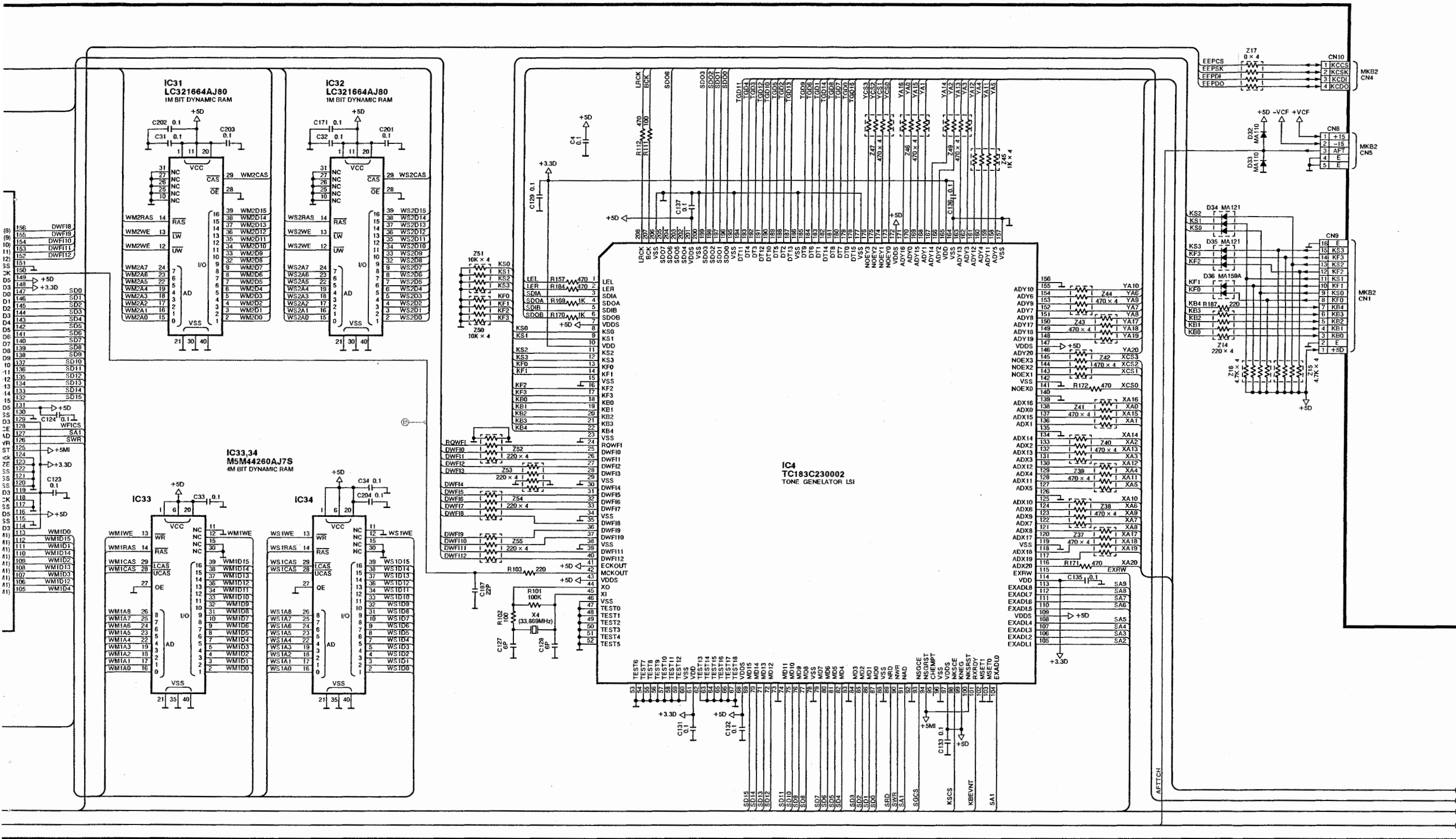

MAIN (C) P.C. Diagram

F

E

D

C

B

A

MAIN(C)

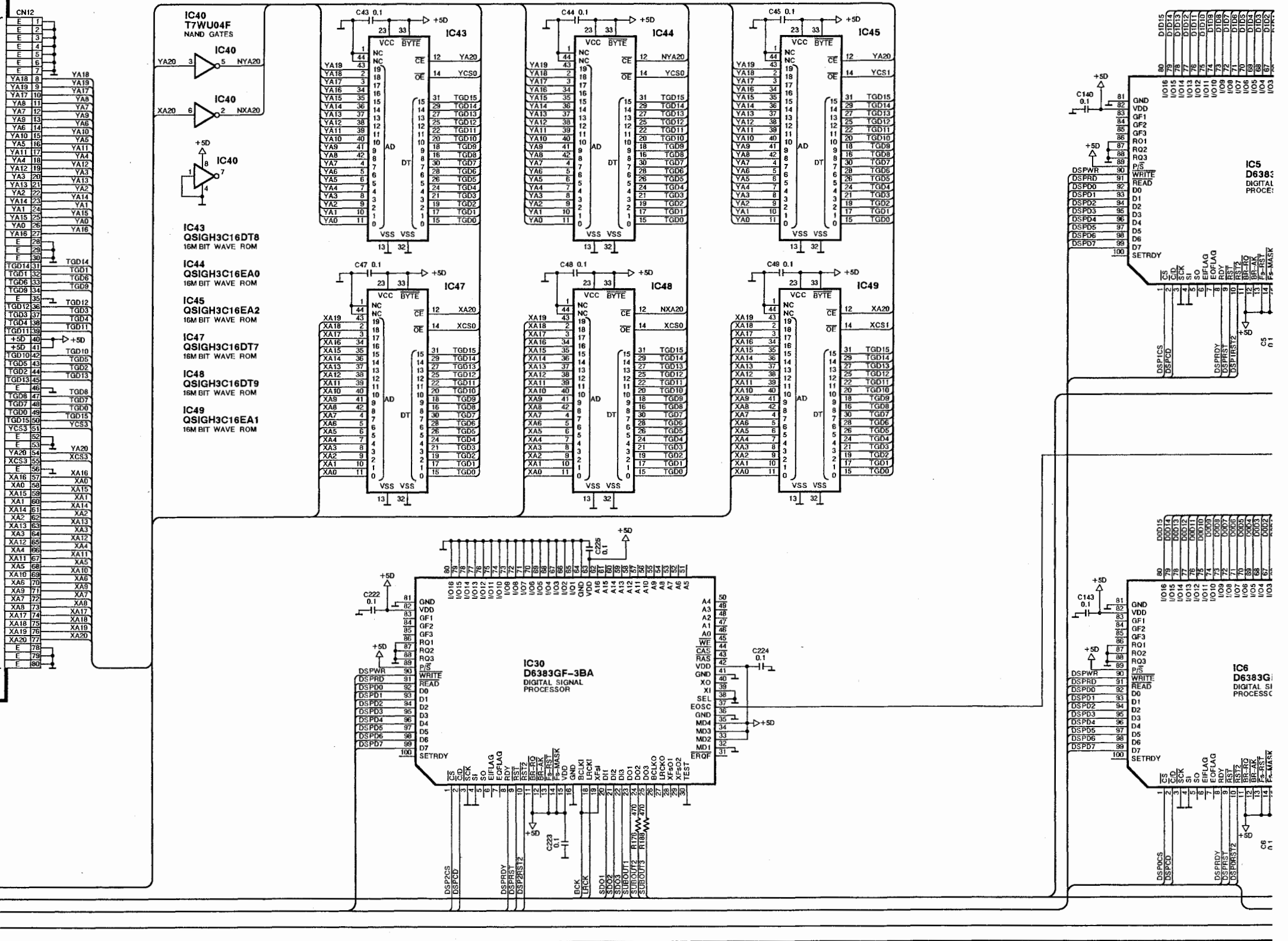

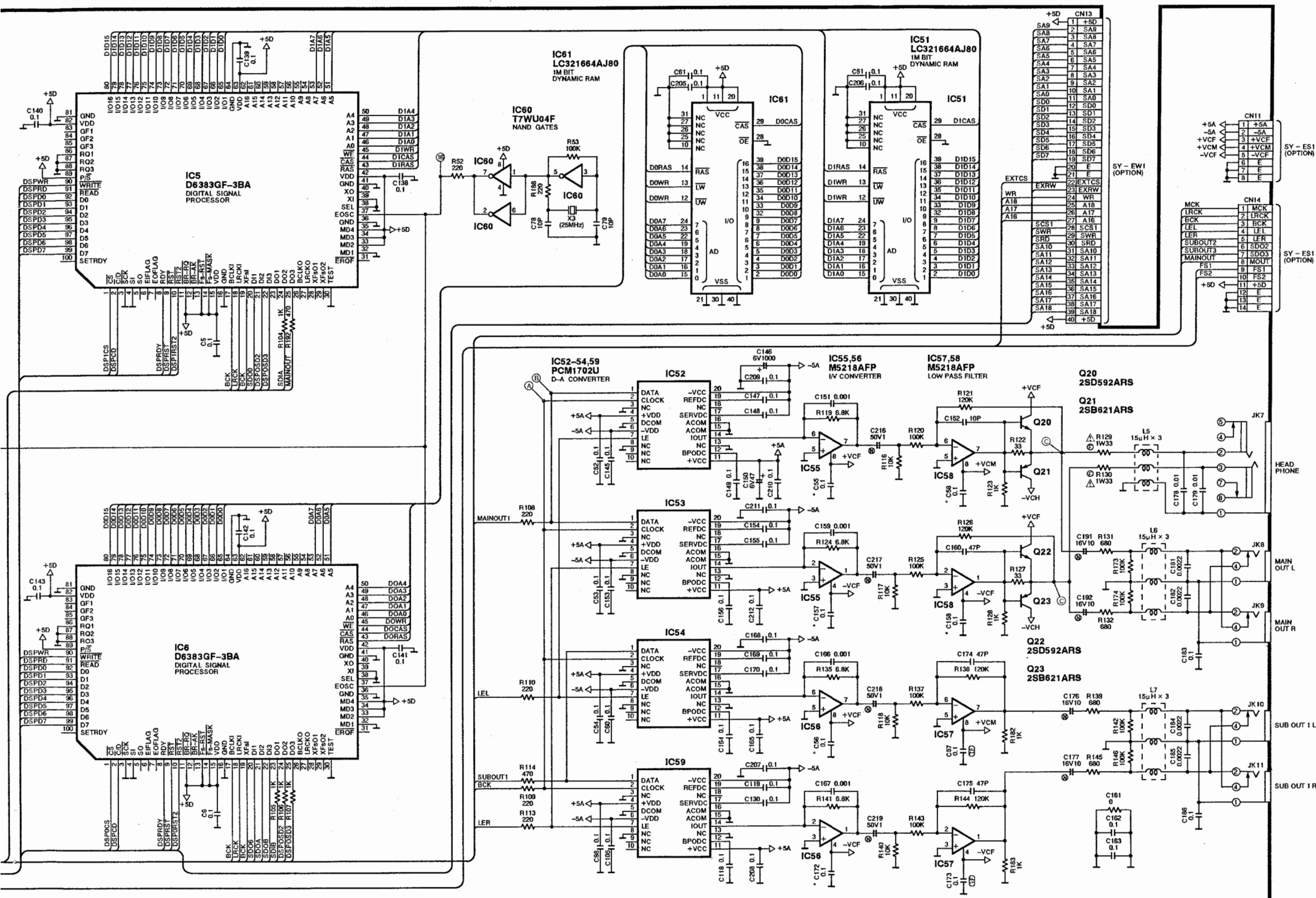

MAIN (COMPONENT SIDE) P.C. Board

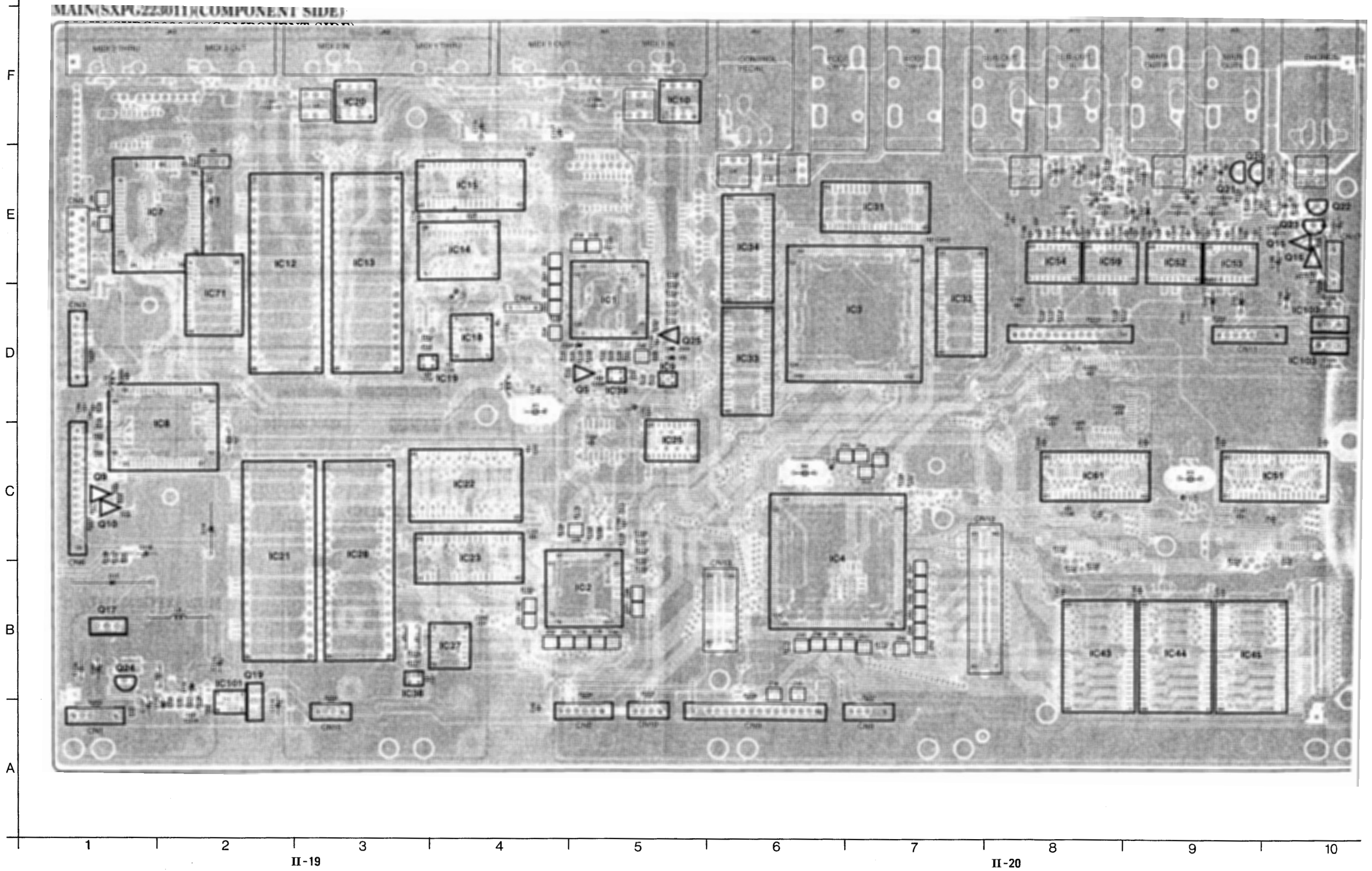

Measuring Condition

Set to the self-diagnostic mode followings.

- While pressing two E keys (E3, E4) simultaneously, turn on the power switch.
- SOUND/COMBINATION GROUP 6
- Keyboard C1

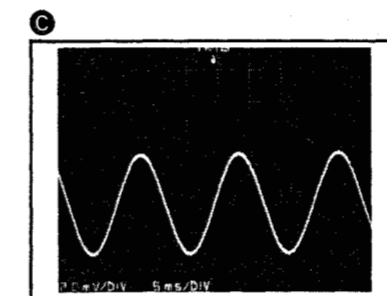
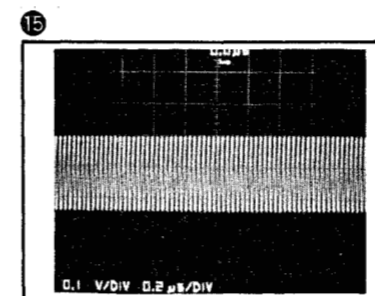
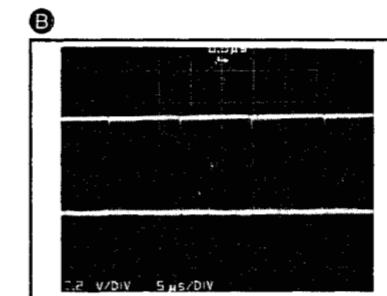
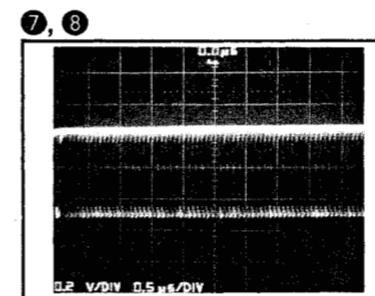
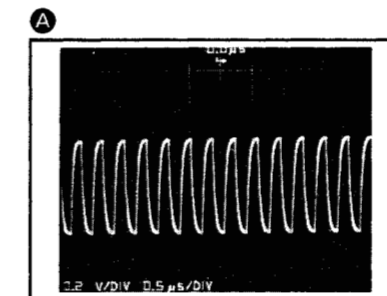
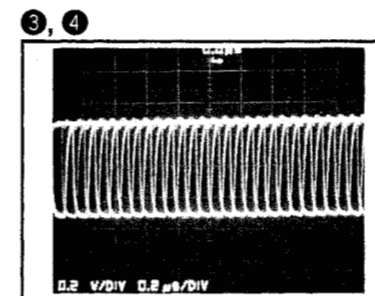
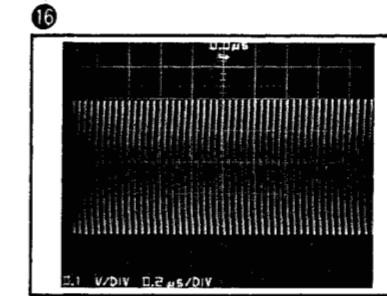
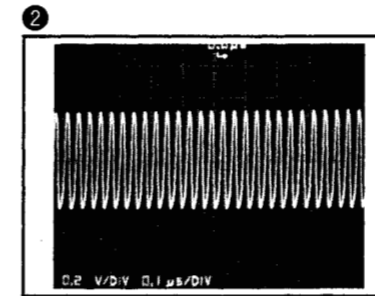
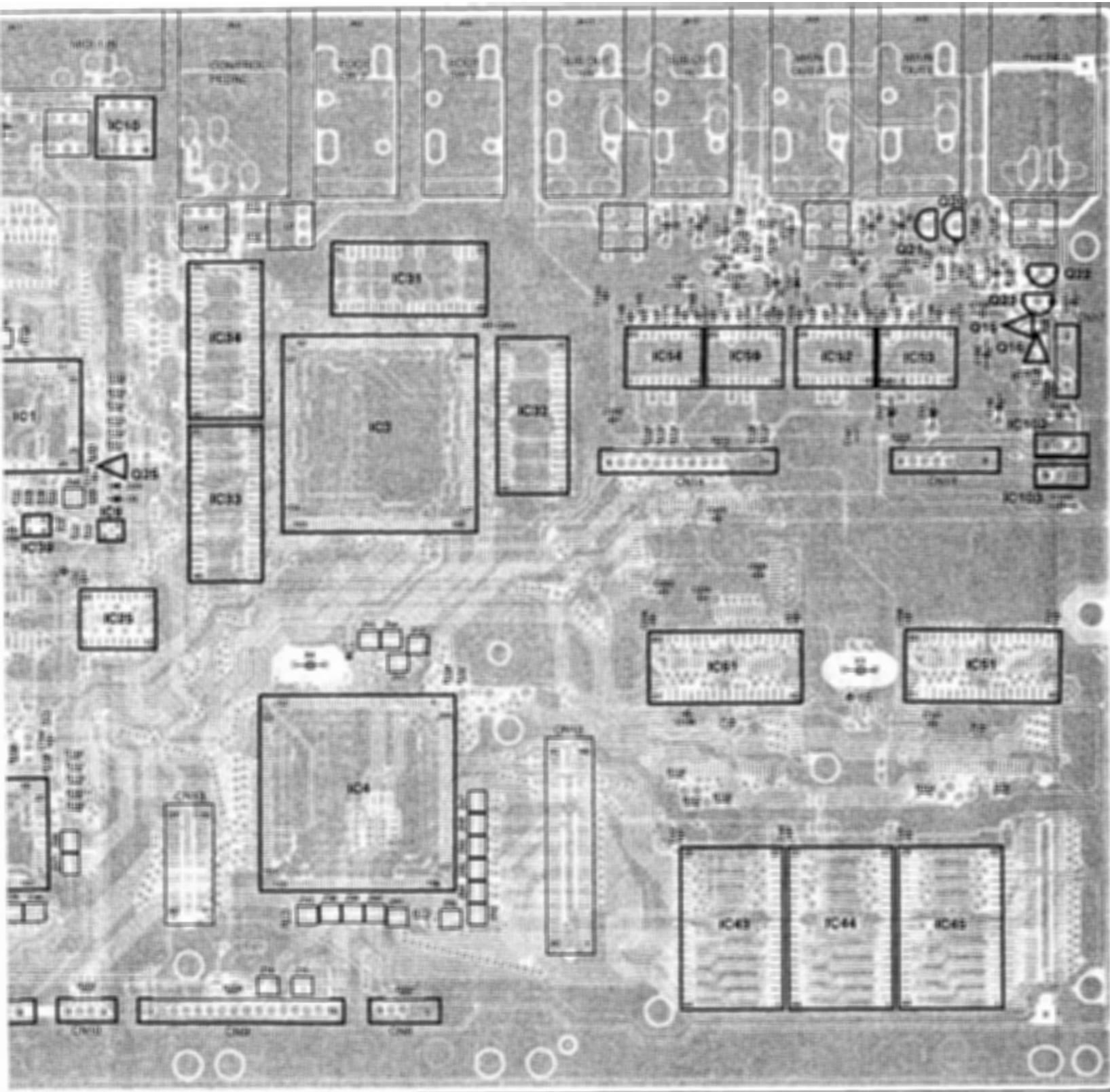

MAIN (FOIL SIDE)/MB1/MB2/ACP P.C. Board

MAIN(SXPG223011)(FOIL SIDE)

F
E
D
C
B
A

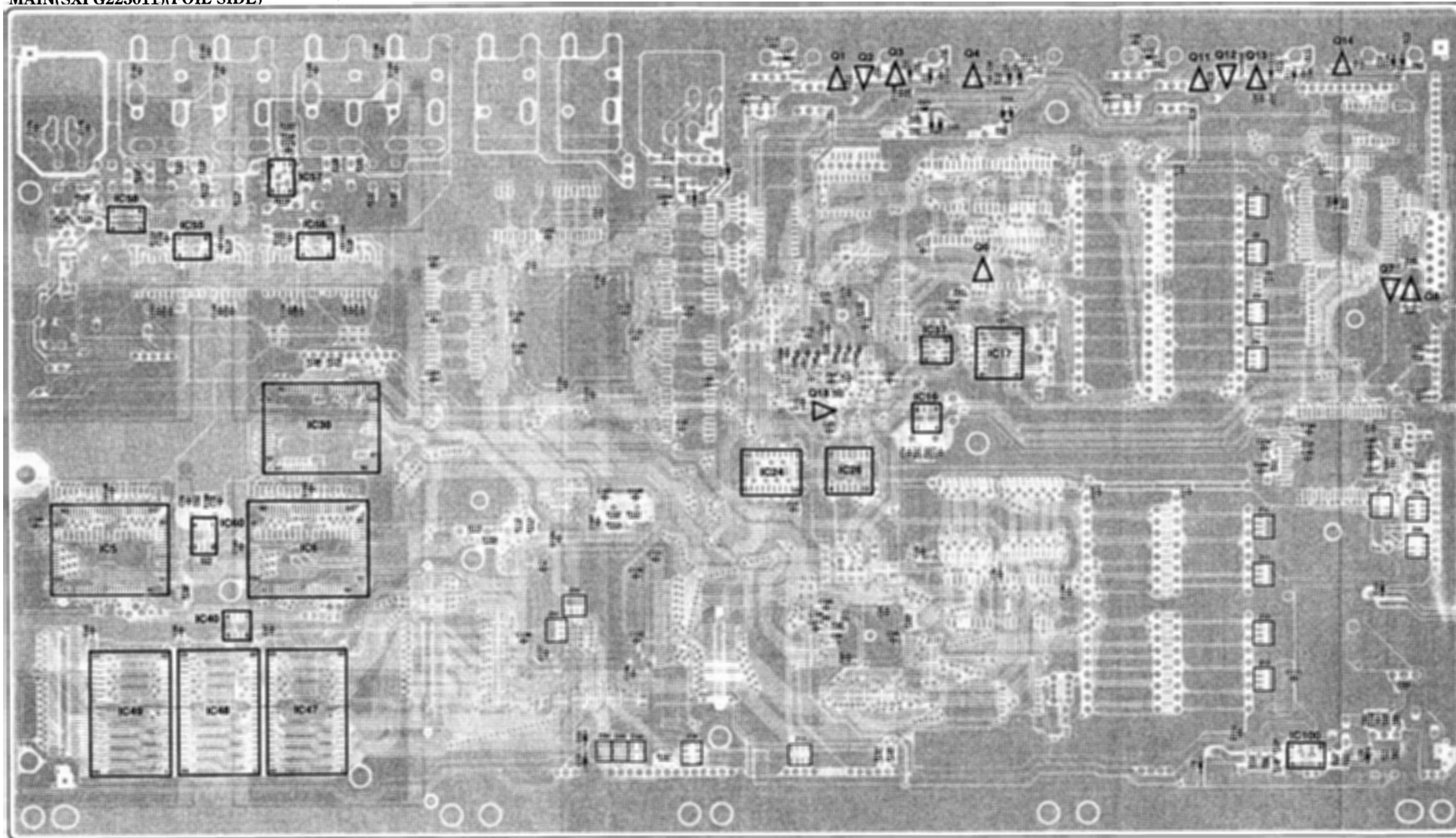

1 2 3 4 5 6 7 8 9 10

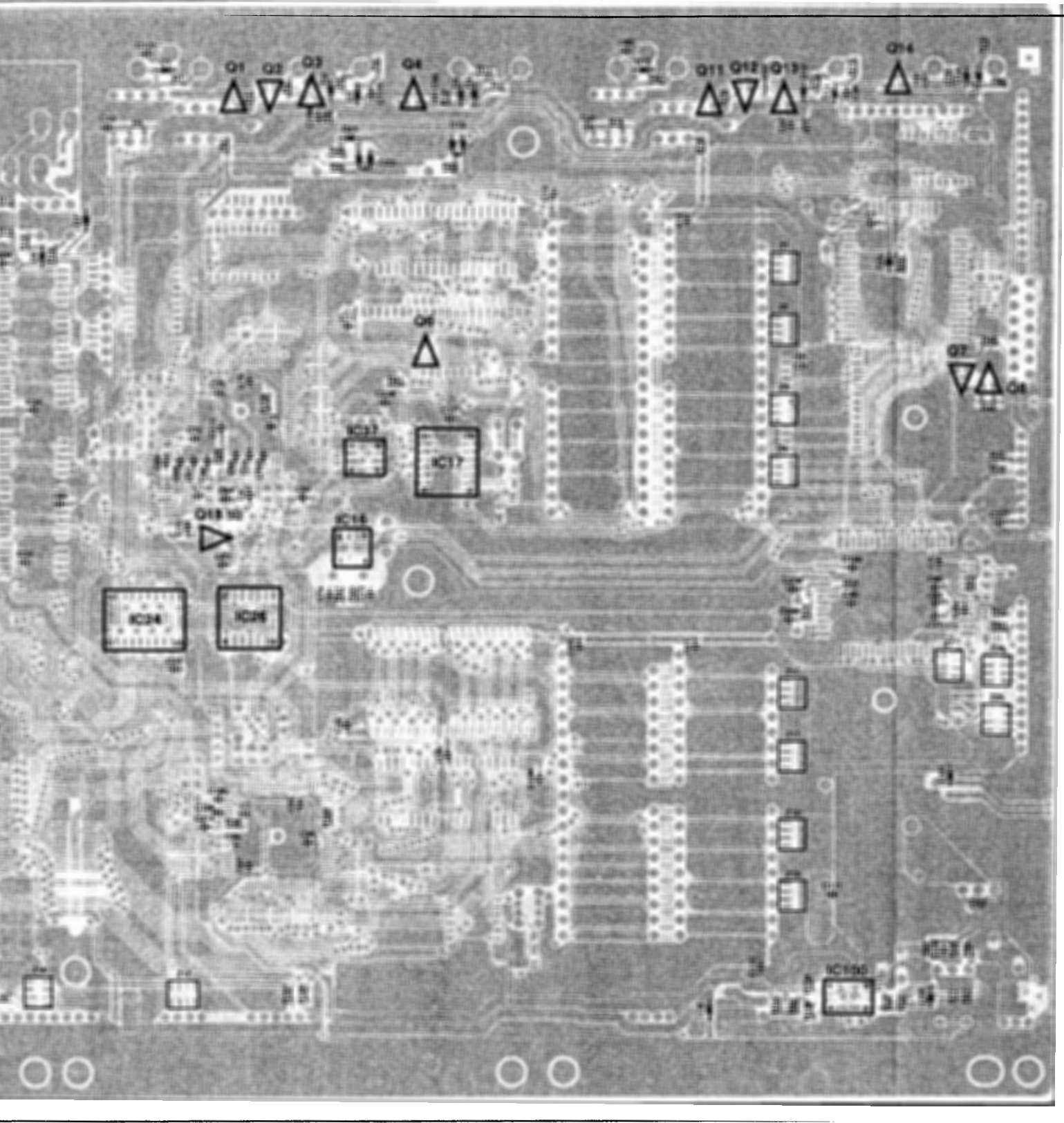

ACP **X XR XS XD XT** (SXPG223241A)

M MC XM (SXPG223231A) Others (SXPG223211A)

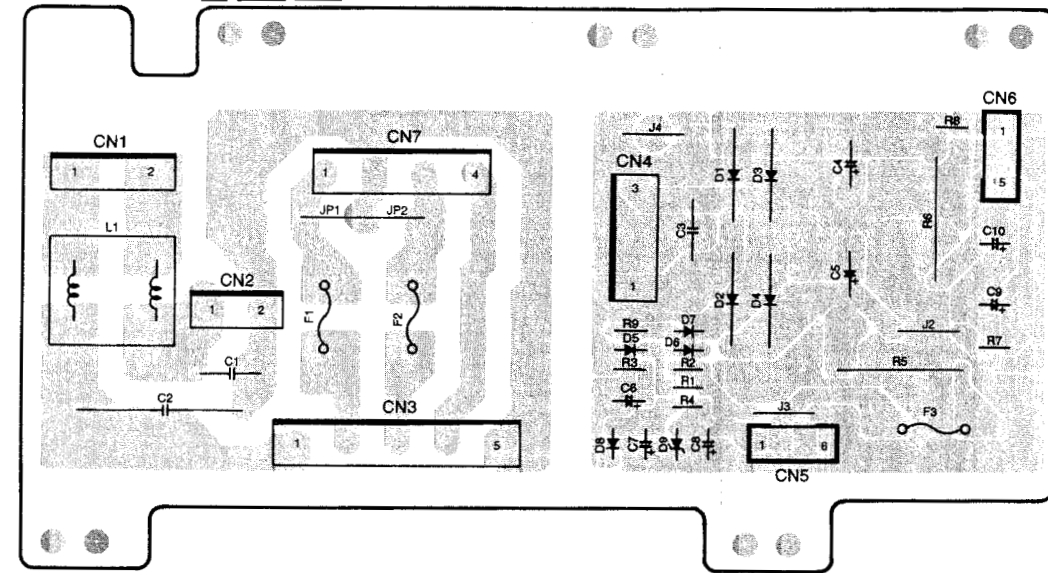

ACP P.C. Board

SXPG NO.	AREA	F1	F2	F3	CN7	JP1	JP2
223241A	X XR XS XD XT	XBA2C10TB0	XBA2C05TB0	XBA2C20TB0	○	×	×
223231A	M MC XM	XBA1C16NU100	×	XBA1C25NU100	×	○	×
223211A	Others	×	XBA2C05TB0	XBA2C20TB0	×	×	○

MB1(SXPG223211C)

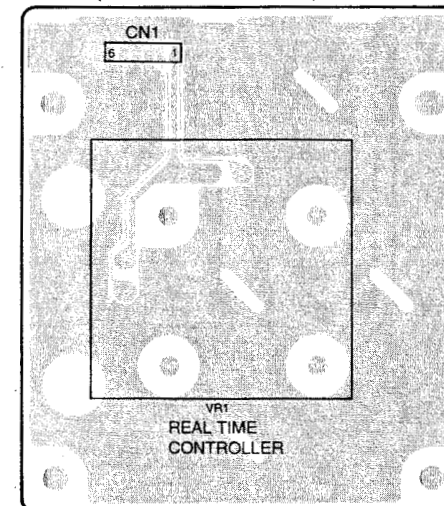

MB2(SXPG223211D)

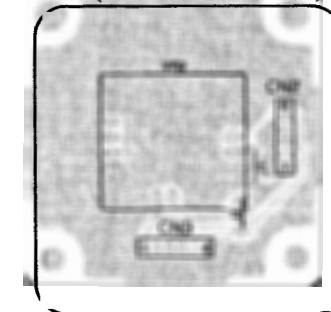

ACP P.C. Diagram

F

E

D

C

B

A

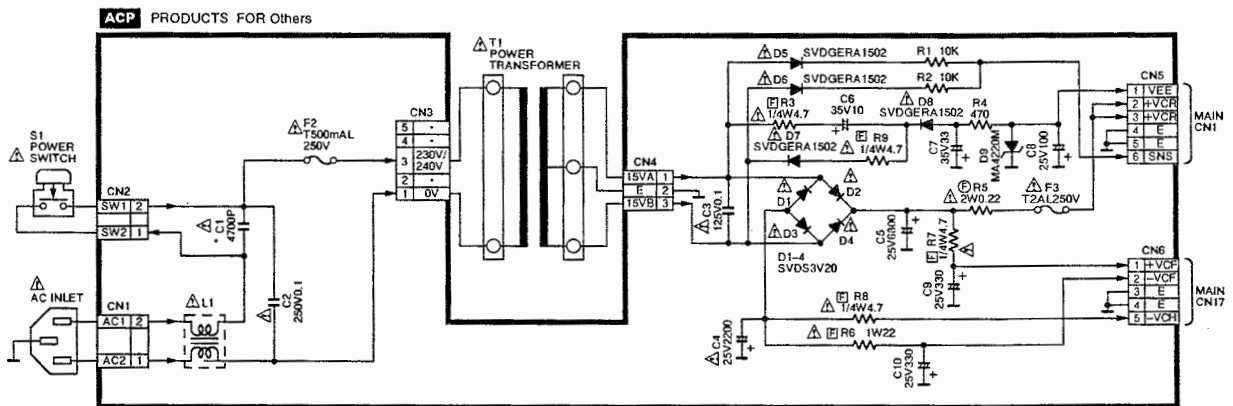
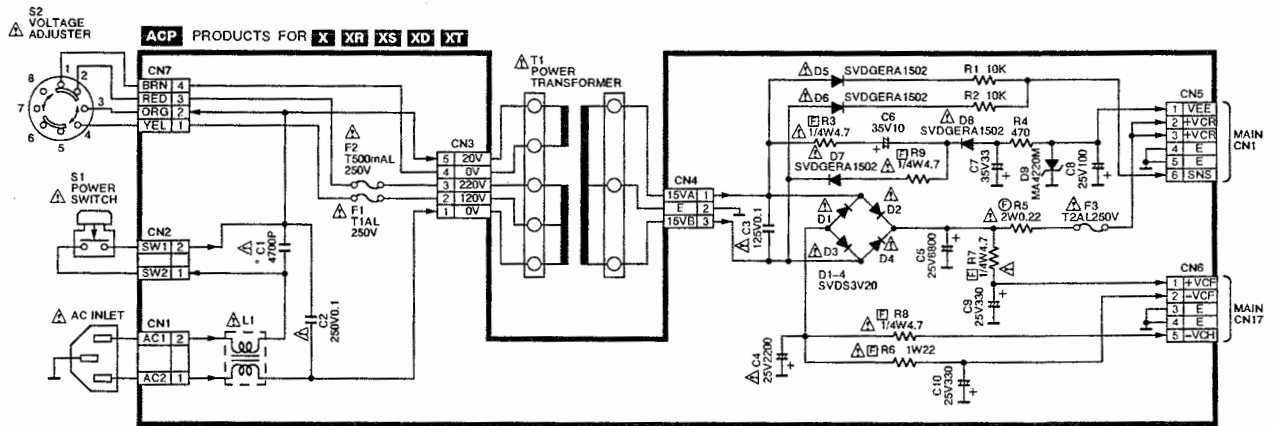
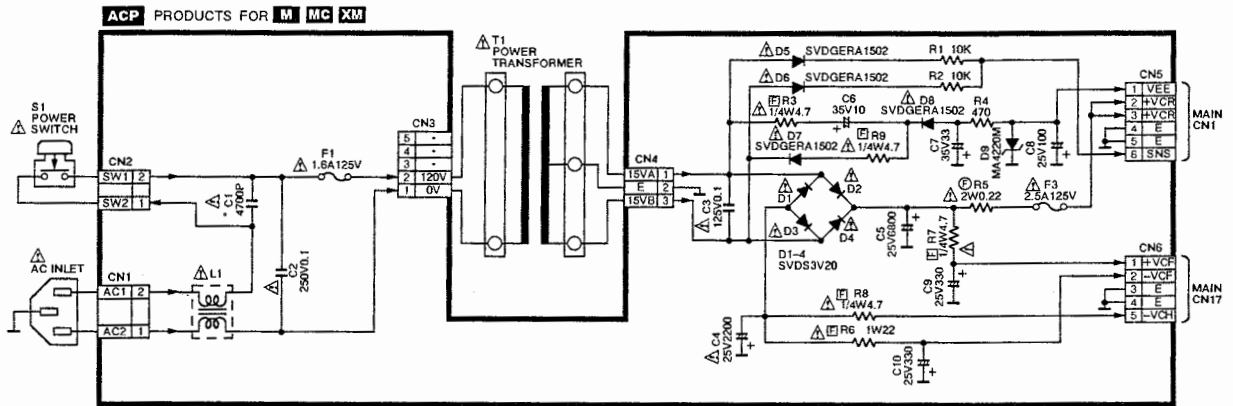

INV

INV(SXPG223211B)

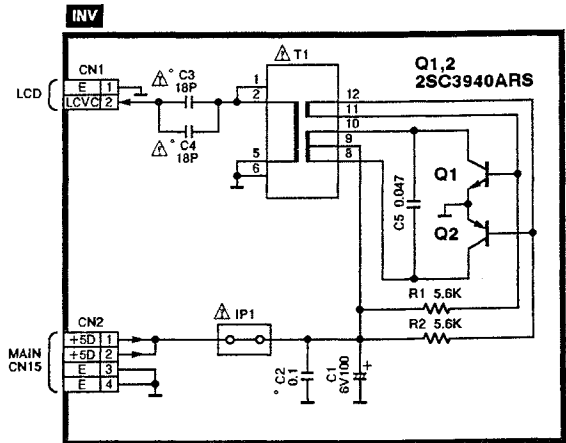
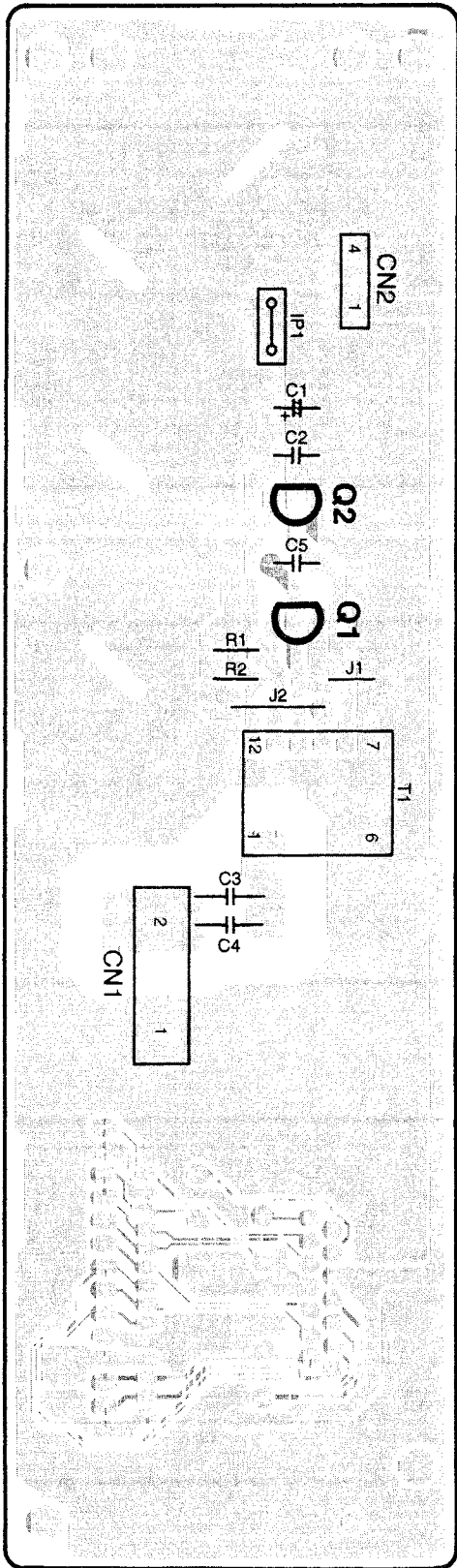

CPC/CPL/CPR/MOD1/MOD2/BEND/CNB P.C. Board

F
E
D
C
B
A

CPC(SXPG22311A)

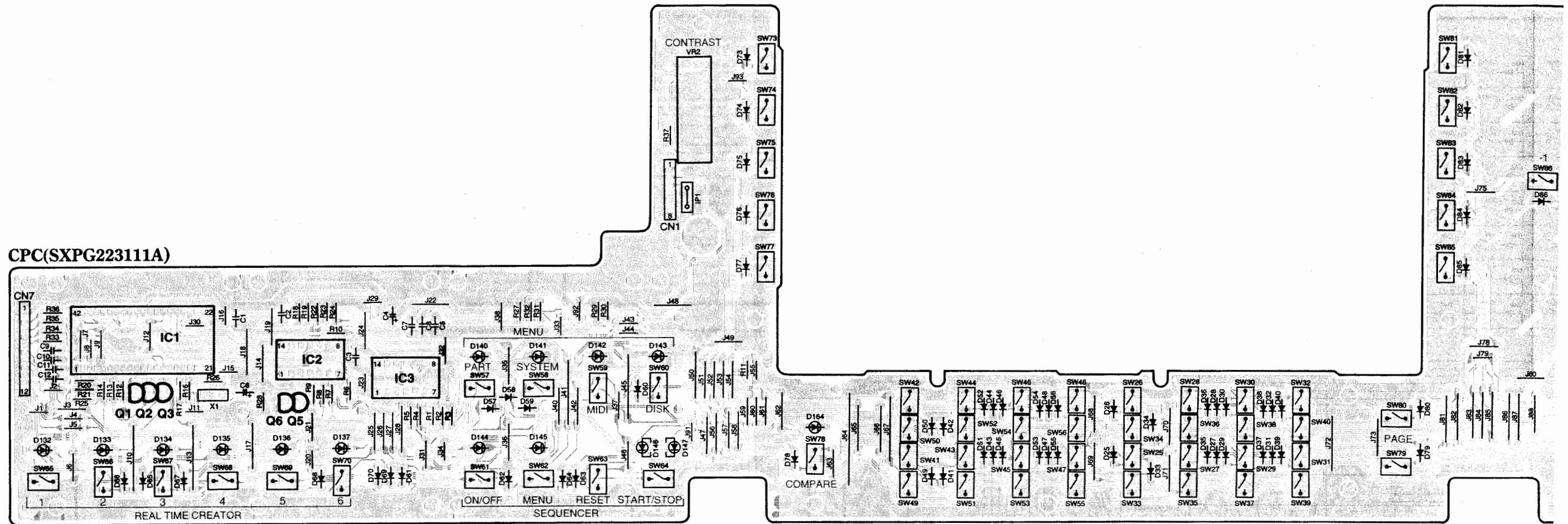

CPR(SXPG22311B)

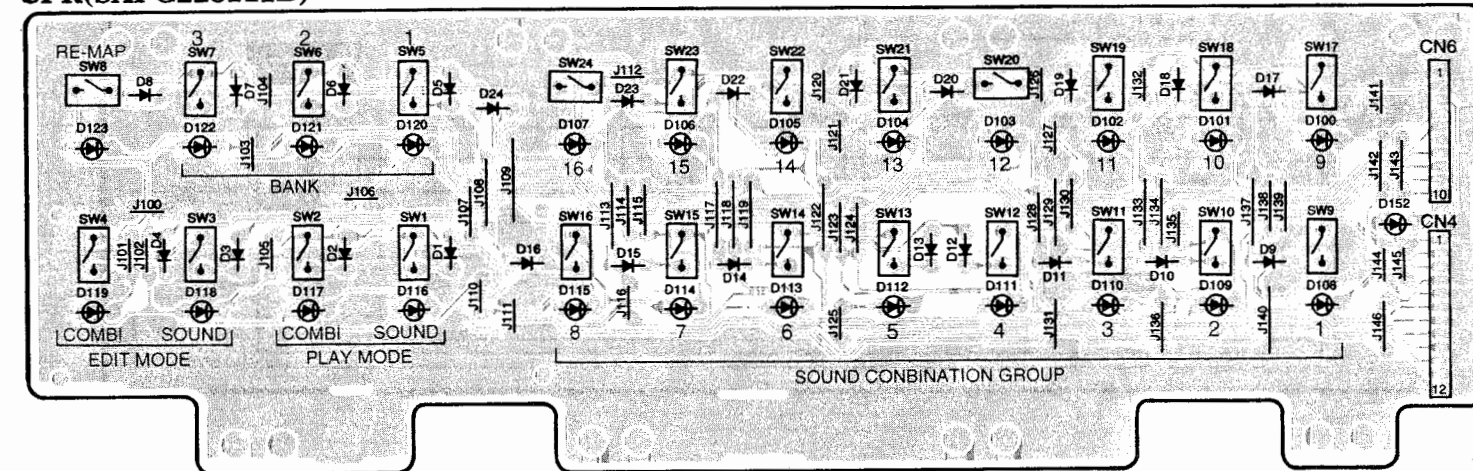

MOD1(SXPG224511B)

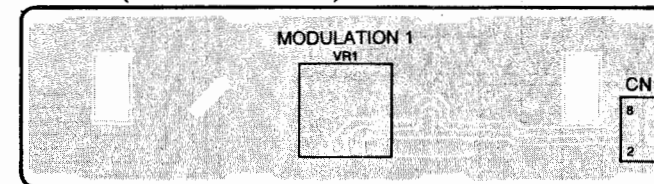

MOD2(SXPG224511C)

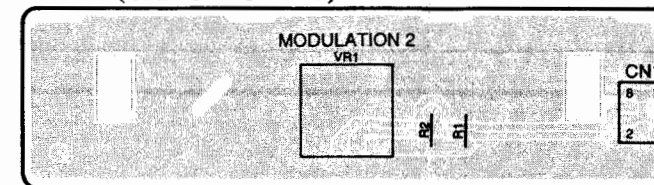

BEND(SXPG224511D)

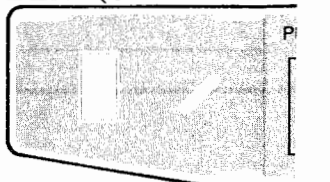

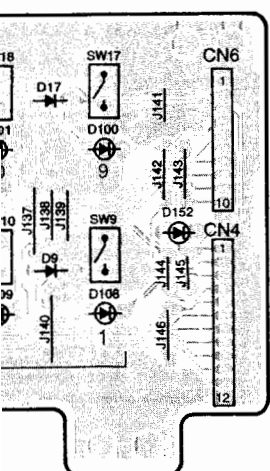
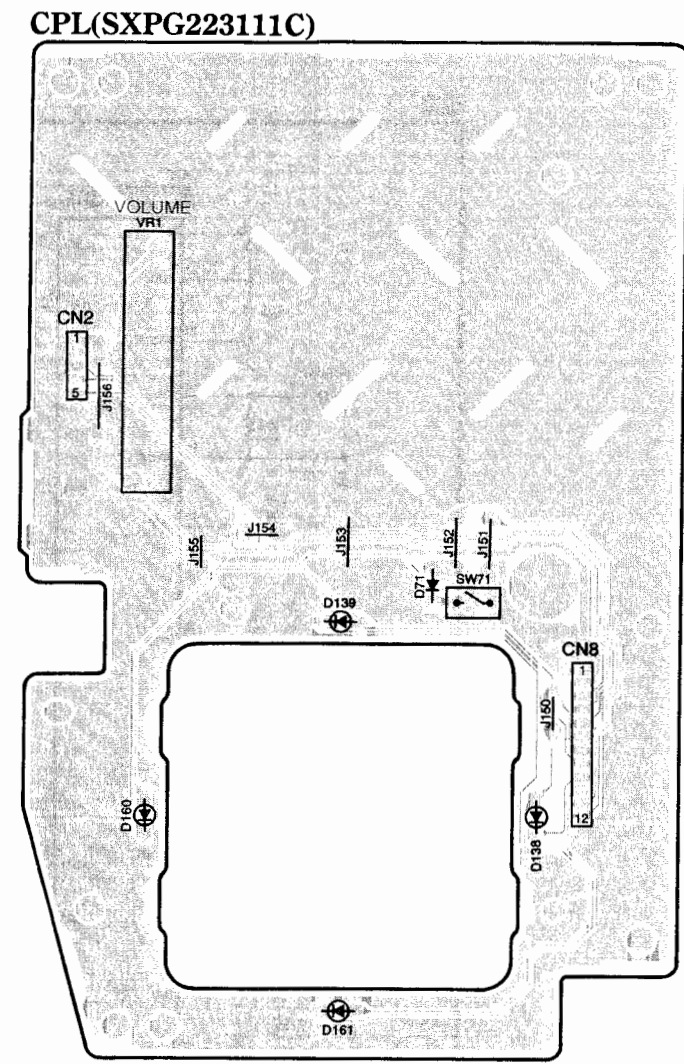
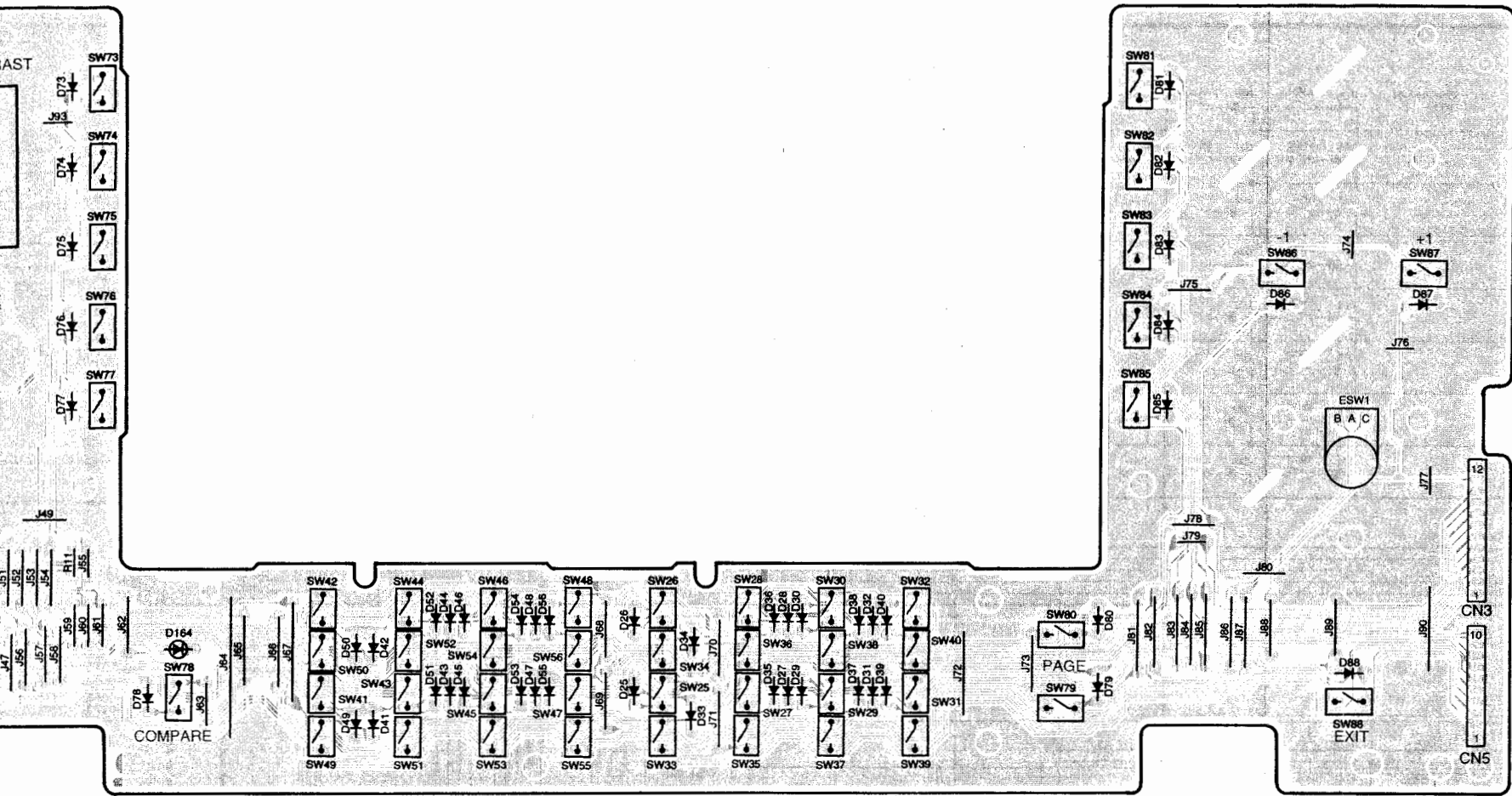

MOD1(SXPG224511B)

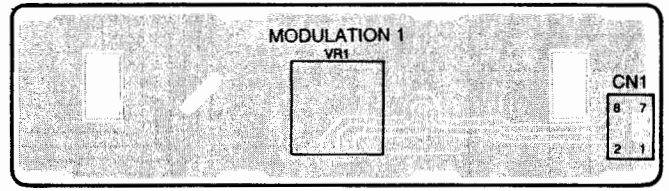

MOD2(SXPG224511C)

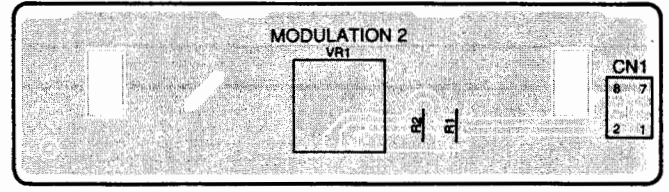

BEND(SXPG224511A)

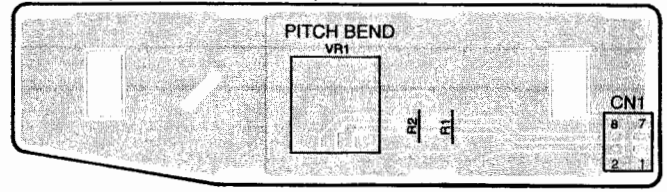

CNB(SXPG224511D)

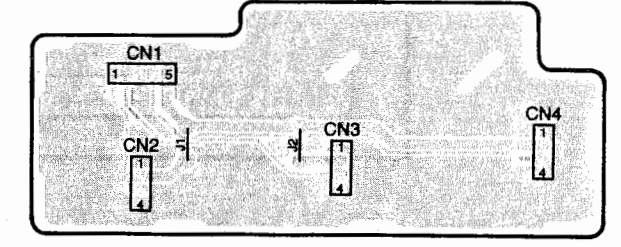

CPC/CPL/CPR/MOD1/MOD2/BEND/CNB P.C. Diagram

F
E
D
C
B
A

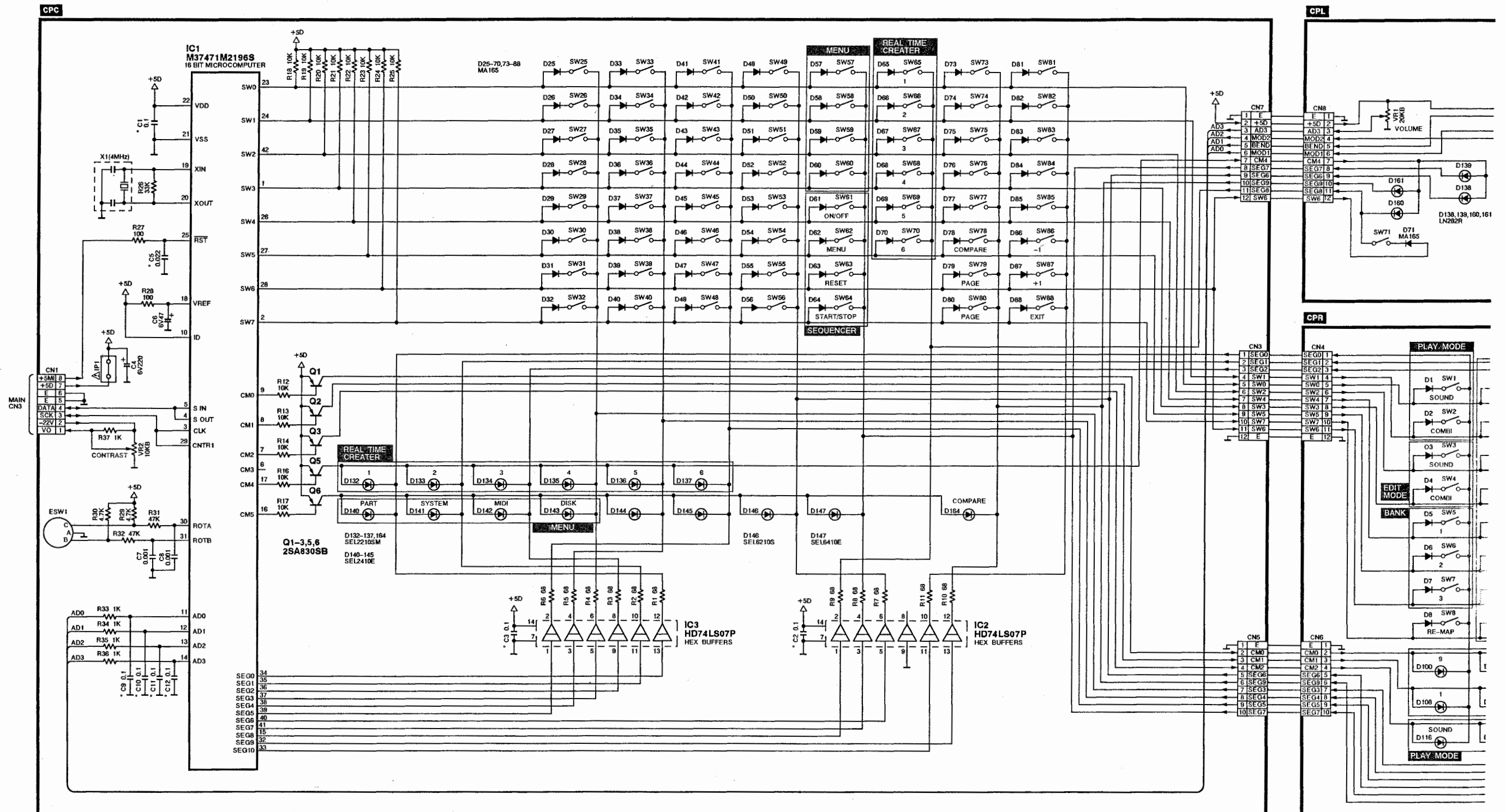

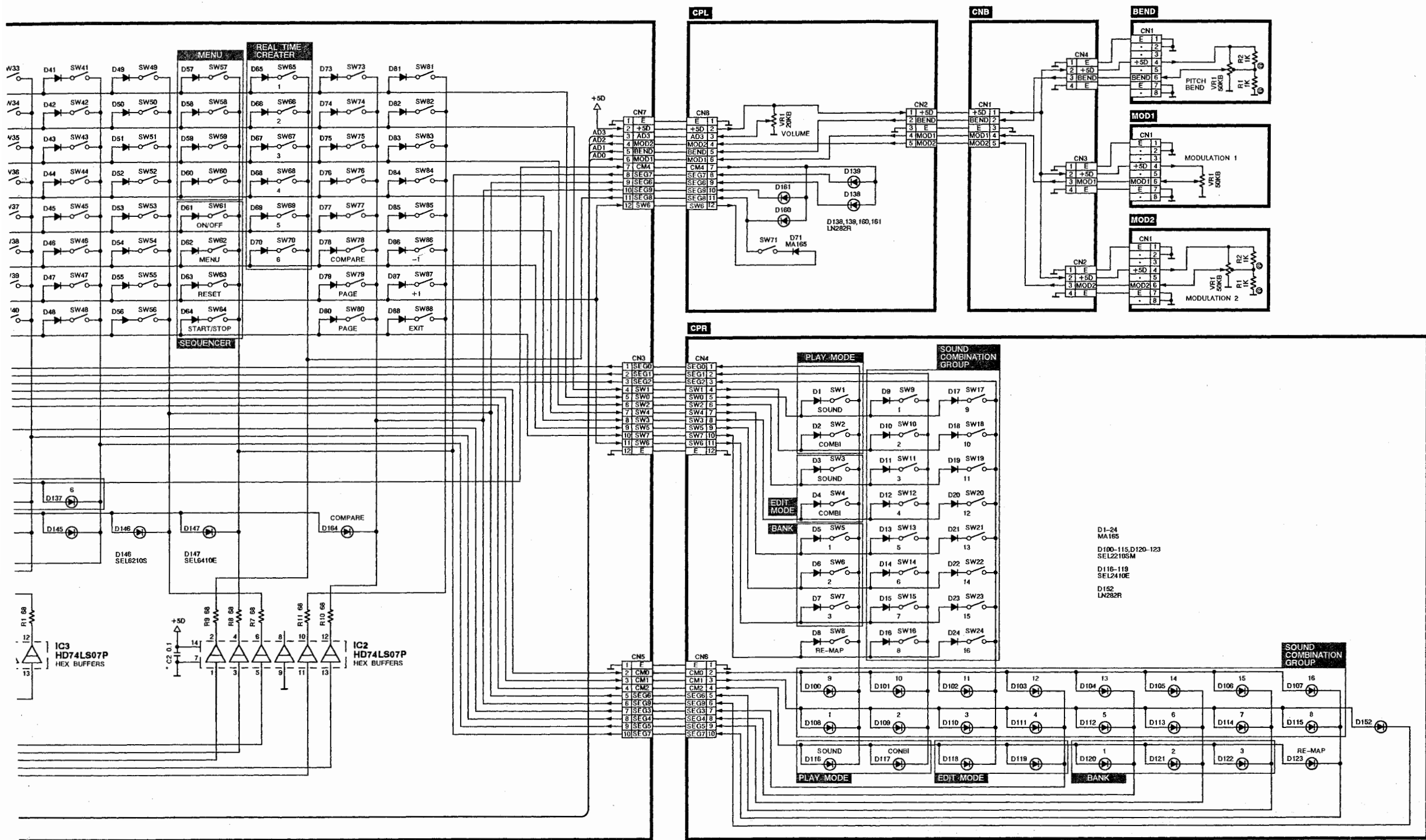

MKB1/MKB2

MKB2(SXPG222121)

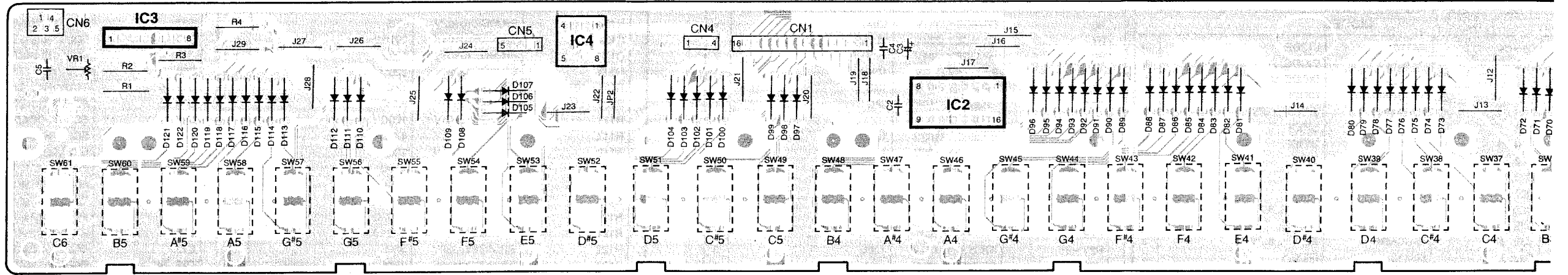

MKB1 (SXPG222011)

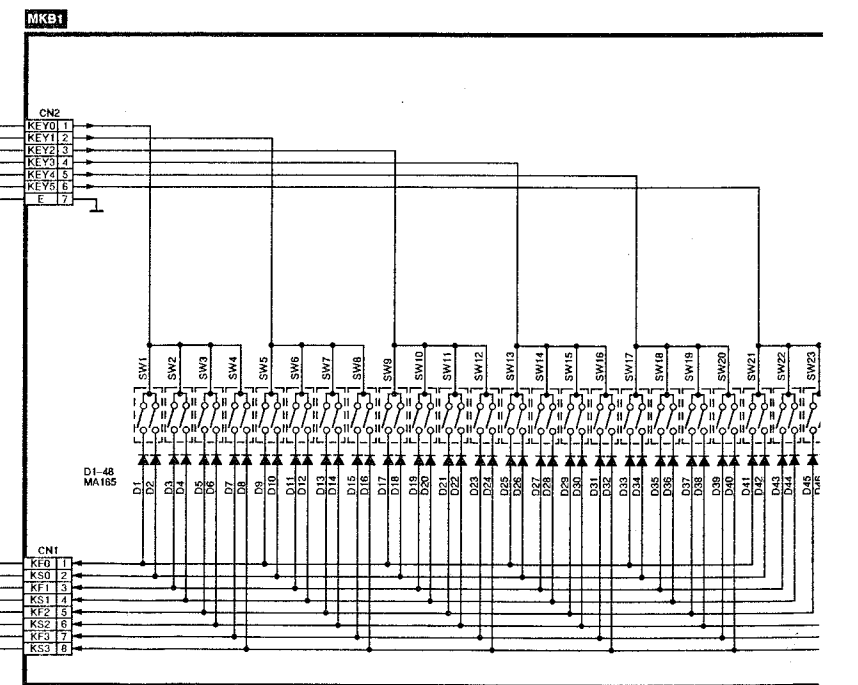
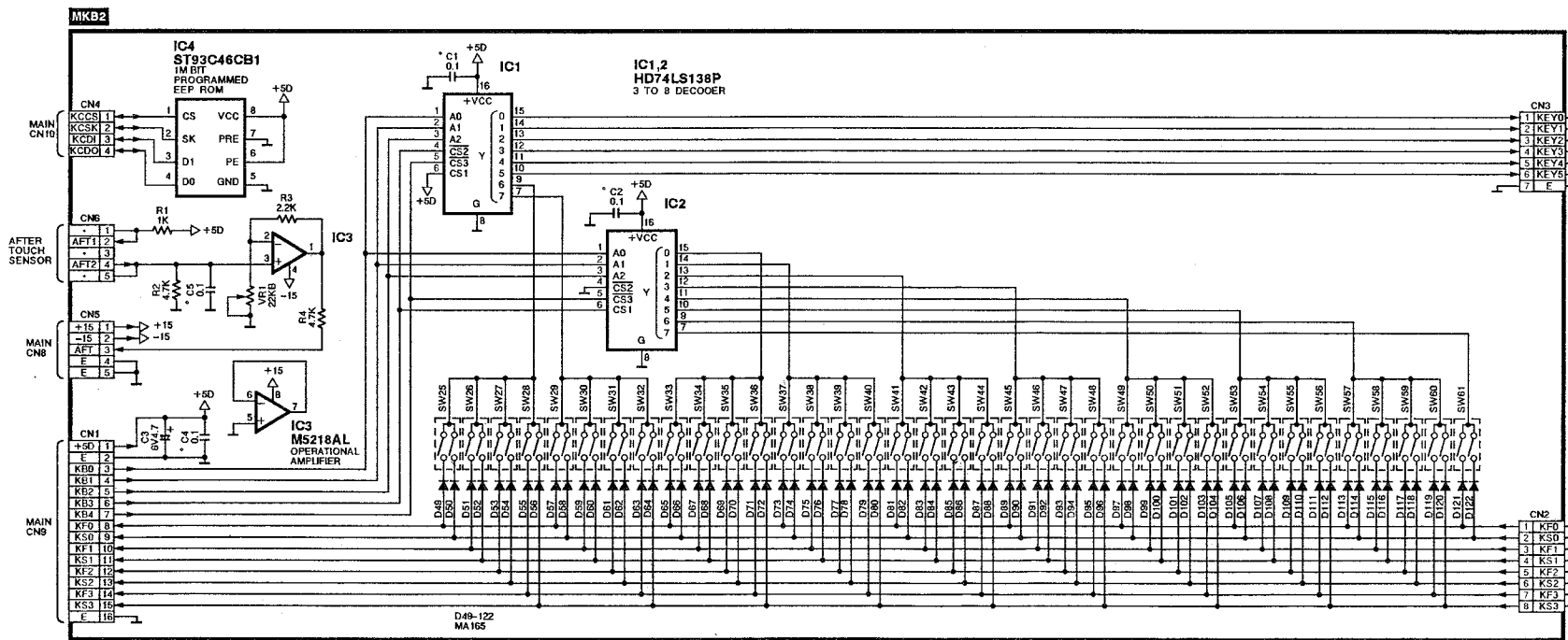
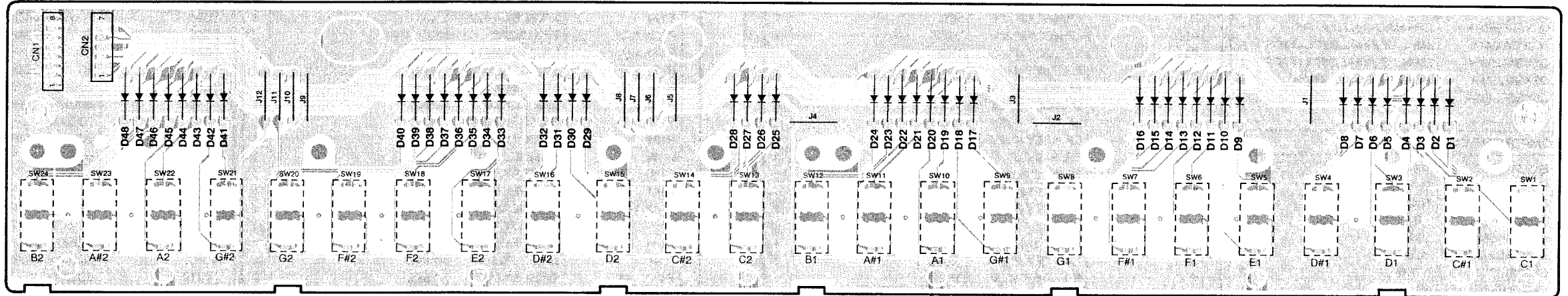

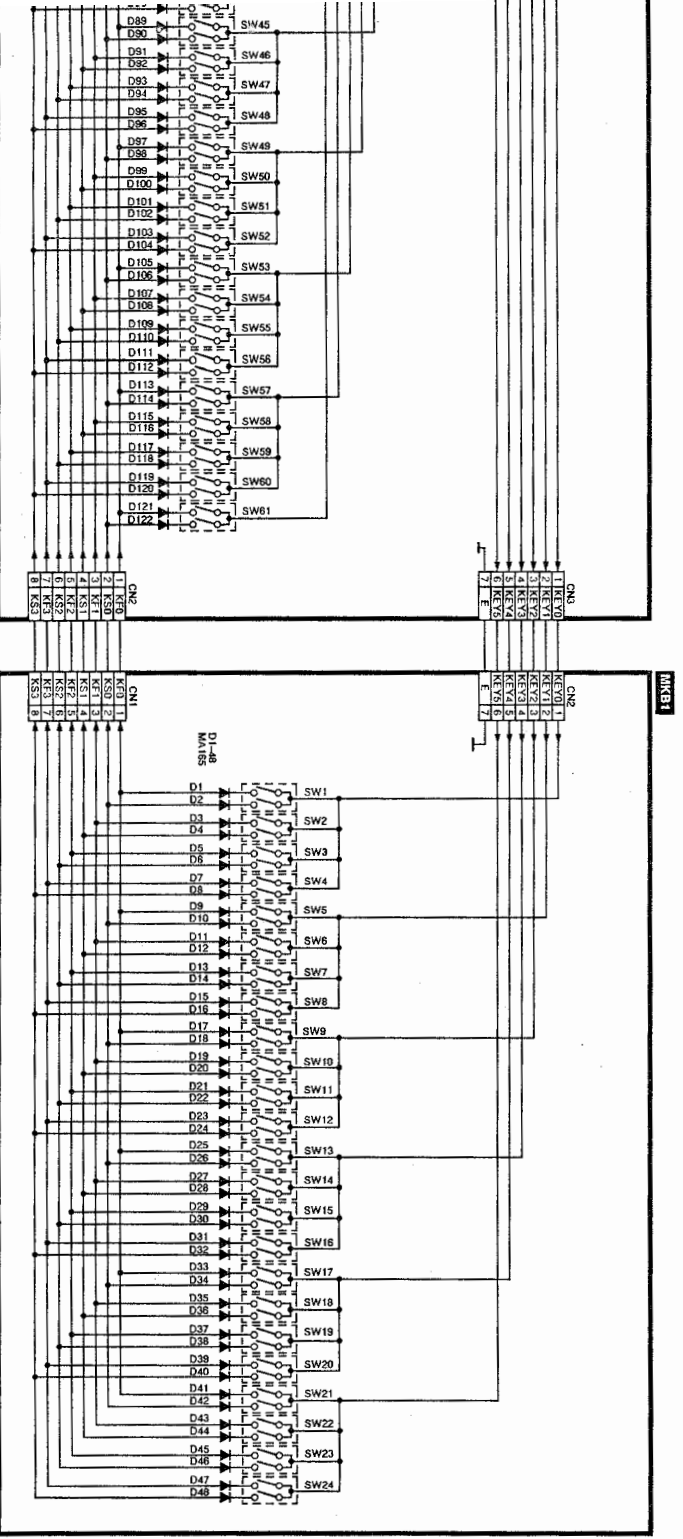
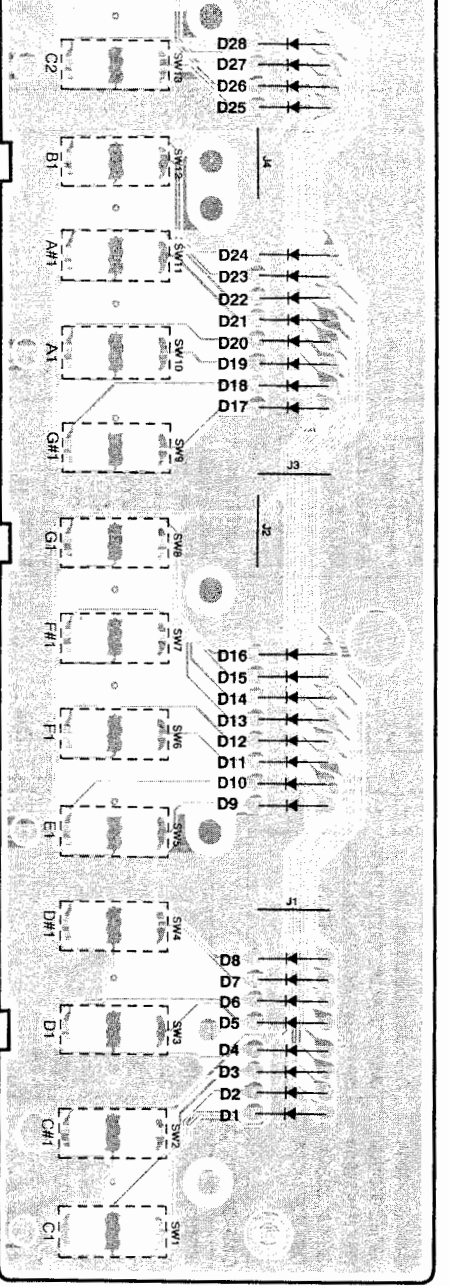
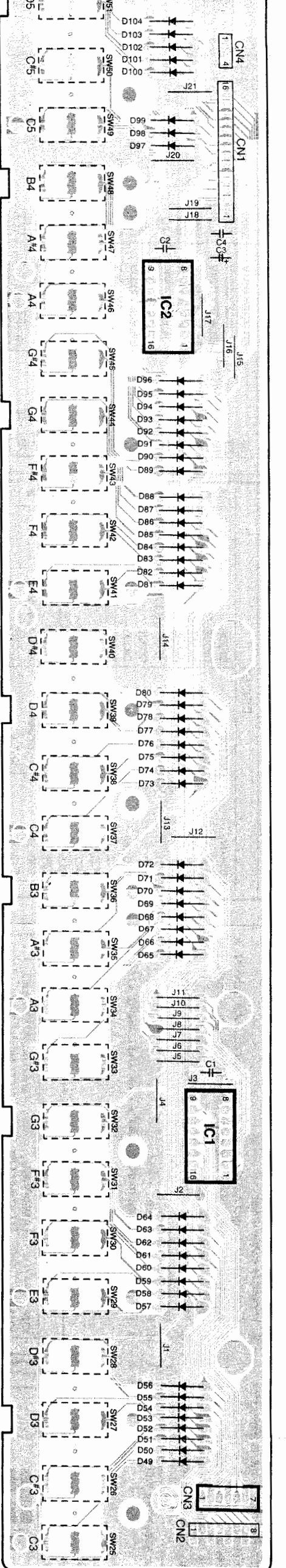

II-34

II-35

6 7 8 9 10 11 12 13 14

REPLACEMENT PARTS LIST.....P.C.B. and Wiring Parts

Notes:

1. The marking (RTL) indicates that the Retention Time is limited for this item. After the discontinuation of this assembly in production, the item will continue to be available for a specific period of time. The retention period of availability is dependant on the type of assembly, and in accordance with the laws governing part and product retention.
After the end of this period, the assembly will no longer be available.

2. Important safety notice
Components identified by Δ mark have special characteristics important for safety. When replacing any of these components, use only manufacturer's specified parts.
3. The "S" mark is service standard parts and may differ from production parts.
4. \circ mark are new parts.
5. For part No. with area mark, check the area when placing an order.

PRINTED CIRCUIT BOARD

RTL	Area	Part No.	Description	P/S
\circ		SXPG223011	MAIN	1
\circ		SXPG223211C	MB1	1
\circ		SXPG223211D	MB2	1
\circ		SXPG223211A	ACP	1
	EN EK EZ EW			
	EF EA EH EP			
	XL XP			
\circ	M MC XM	SXPG223231A	ACP	1
\circ	X XR XS XD	SXPG223241A	ACP	1
	XT			
\circ		SXPG223211B	INV	1
\circ		SXPG223111A	CPC	1
\circ		SXPG223111C	CPL	1
\circ		SXPG223111B	CPR	1
\circ		SXPG224511B	MOD1	1
\circ		SXPG224511C	MOD2	1
\circ		SXPG224511A	BEND	1
\circ		SXPG224511D	CNB	1
\circ		SXPG222011	MKB1	1
\circ		SXPG222121	MKB2	1
\circ		QSLG017AA	LCD	1

MAIN MAIN CIRCUIT

Ref. No.	Part No.	Description	P/S
INTEGRATED CIRCUITS			
IC1, 2	TMP95C061AF	IC, MICROCONTROLLER, 16BIT	2
IC3	L7A1429	TONE GENERATOR	1
IC4	TC183C230002	IC, MICROCONTROLLER, 8BIT	1
IC5, 6	D6383GF-3BA	IC, MICROCONTROLLER, 16BIT	2
IC7	SED1330FBA	LCD CONTROLLER	1
IC8	D72070GF3BE	IC, MICROCONTROLLER, 8BIT	1
IC9	TC7S14F	OR GATE	1
IC10	QCPL-260L	PHOTO COUPLER	1
IC12	QSIGCWSA1AX	IC, 4M EP ROM	1
IC12-1	(M27C400210F1	(BLANK ROM)	1
IC13	QSIGCWSA1BX	IC, 4M EP ROM	1
IC13-1	(M27C400210F1	(BLANK ROM)	1
IC14	M5256CFP70LL	IC, S RAM	1
IC15	M5M44170AJ7S	IC, D RAM 4M BIT	1
IC16	T7WU04F	IC, CMOS LOGIC	1
IC17	D74HC139GS	IC, CMOS LOGIC	1
IC18	D74HC138GS	IC, CMOS LOGIC	1
IC19	TC7S08F	IC, CMOS LOGIC	1
IC20	QCPL-260L	PHOTO COUPLER	1
IC21	QSIGCWSA1DX	IC, 4M EP ROM	1
IC21-1	(M27C400210F1	(BLANK ROM)	1

Ref. No.	Part No.	Description	P/S	
\circ	IC22	AM29F400T	IC, FLASH MEMORY 4M BIT	1
	IC23	LC321664AJ80	1M BIT DYNAMIC RAM	1
	IC24, 25	D74HC374GS	IC, CMOS LOGIC	2
	IC26	D74HC32GS	QUAD 2 INPUT OR GATE	1
	IC27	D74HC139GS	IC, CMOS LOGIC	1
\circ	IC28	QSIGCWSA1CX	IC, 4M EP ROM	1
	IC28-1	(M27C400210F1	(BLANK ROM)	1
	IC30	D6383GF-3BA	IC, MICROCONTROLLER, 16BIT	1
	IC31, 32	LC321664AJ80	1M BIT DYNAMIC RAM	2
\circ	IC33, 34	M5M44260AJ7S	IC, D RAM 4M BIT	2
	IC37	TC7W08F	DUAL 2-INPUT AND GATES	1
\circ	IC38	TC7S08F	IC, CMOS LOGIC	1
	IC39	TC7S14F	OR GATE	1
	IC40	T7WU04F	IC, CMOS LOGIC	1
\circ	IC43	QSIGH3C16DT8	IC, MASK ROM 16M BIT	1
	IC44	QSIGH3C16EA0	IC, MASK ROM 16M BIT	1
\circ	IC45	QSIGH3C16EA2	IC, MASK ROM 16M BIT	1
	IC47	QSIGH3C16DT7	IC, MASK ROM 16M BIT	1
\circ	IC48	QSIGH3C16DT9	IC, MASK ROM 16M BIT	1
\circ	IC49	QSIGH3C16EA1	IC, MASK ROM 16M BIT	1
\circ	IC51	LC321664AJ80	1M BIT DYNAMIC RAM	1
	IC52~54	PCM1702U	D-A CONVERTER	3
	IC55~58	M5218AFP	OPERATIONAL AMPLIFIER	4
	IC59	PCM1702U	D-A CONVERTER	1
	IC60	T7WU04F	IC, CMOS LOGIC	1
	IC61	LC321664AJ80	1M BIT DYNAMIC RAM	1
	IC71	LH5P832N-10	256K BIT PSEUDO STATIC RAM	1
	IC100	BA10393F	COMPARATOR	1
	IC101	M5223FP	IC, LINER	1
	IC102	Δ M5F7805L	VOLTAGE REGULATOR	1
	IC103	Δ M5F7905L	-5V VOLTAGE REGULATOR	1

Ref. No.	Part No.	Description	P/S	
TRANSISTORS				
\circ	Q1	2SD601AQ	TRANSISTOR	1
	Q2~5	2SB709AR	TRANSISTOR	4
	Q6	2SD601AQ	TRANSISTOR	1
	Q7	2SB709AR	TRANSISTOR	1
	Q8, 9	2SD601AQ	TRANSISTOR	2
	Q10	2SB709AR	TRANSISTOR	1
	Q11	2SD601AQ	TRANSISTOR	1
	Q12~15	2SB709AR	TRANSISTOR	4
	Q16	2SD601AQ	TRANSISTOR	1
	Q17	Δ 2SA1643	TRANSISTOR	1
	Q18	2SD601AQ	TRANSISTOR	1
	Q19	2SB941P	TRANSISTOR	1
	Q20	2SD592ARS	TRANSISTOR	1
	Q21	2SB621ARS	TRANSISTOR	1
	Q22	2SD592ARS	TRANSISTOR	1
	Q23	2SB621ARS	TRANSISTOR	1
	Q24	2SC1815GR	TRANSISTOR	1
S	Q25	2SB709AR	TRANSISTOR	1

Ref. No.	Part No.	Description	P/S	
DIODES				
\circ	D1~14	MA110	DIODE	14
	D15	MA8082M	DIODE, SI	1
\circ	D16	MA8056L	DIODE, SI	1
	D17	Δ SVDGERC9102	DIODE	1
	D18	Δ MA2062LF	ZENER, 6.2V	1
	D19	MA151WK	DIODE	1
	D20, 21	MA110	DIODE	2
	D22	MA151WK	DIODE	1
	D25, 26	MA110	DIODE	2
	D27	EK04	DIODE	1
	D28	MA8030L	ZENER, 3.1V	1
	D29	MA110	DIODE	1
	D30, 31	MA1062M	ZENER, 6.2V	2
	D32, 33	MA110	DIODE	2
	D34, 35	MA121	DIODE, SI, 100mA	2
	D36	MA159A	DIODE, SI, 100mA	1

Ref. No.	Part No.	Description	P/S	
OSCILLATORS				
\circ	X1	QSXG2F2800A	CERAMIC OSCILLATOR	1
	X2	EF0EC8004A5	8MHz, CERAMIC OSCILLATOR	1
	X3	QSXG1A2500A	25MHz, QUARTZ OSCILLATOR	1
	X4	QSXG1I3386A	CRYSTAL OSCILLATOR	1
	X5	QSXG2F2400A	CERAMIC OSCILLATOR	1

Ref. No.	Part No.	Description	P/S	
COMPONENT COMBINATIONS				
	Z1~4	EXBS8V103J	10K Ω x4	4
	Z5	EXBV8V221J	220 Ω x4	1
	Z6	EXBV8V102J	1K Ω x4	1
	Z7	EXBS8V102J	1K Ω x4	1
	Z10~13	EXBS8V103J	10K Ω x4	4
	Z14	EXBS8V221J	220 Ω x4	1
	Z15, 16	EXBV8V472J	4.7K Ω x4	2
	Z17	EXBS8VR000	0 Ω x4	1
	Z18~24	EXBV8V470J	47 Ω x4	7
	Z25, 26	EXBS8V470J	47 Ω x4	2
	Z27~29	EXBV8V102J	1K Ω x4	3
	Z30~36	EXBV8V470J	47 Ω x4	7
	Z37~47	EXBV8V471J	470 Ω x4	11
	Z48	EXBV8V102J	1K Ω x4	1
	Z49	EXBV8V471J	470 Ω x4	1
	Z50, 51	EXBS8V103J	10K Ω x4	2
	Z52~55	EXBV8V221J	220 Ω x4	4

Ref. No.	Part No.	Description	P/S	
COILS				
	L1~7	QLQGT3T150SA	15 μ H x3	7
	L8	SLCG3A121T	120 μ H	1
	L9	QLBG002A	0.45 μ H	1
	L10	QLQGT1B800MA	80 μ H	1

Ref. No.	Part No.	Description	P/S	
JACKS				
	JK1~3	QJJG005AA	JACK SOCKET	3
	JK4, 5	QJJG003AA	JACK	2
	JK6, 7	SJJG100A	JACK	2
	JK8~11	QJJG003AA	JACK	4

Ref. No.	Part No.	Description	P/S	
RESISTORS				
	R1	ERJ6GEYJ221V	220 Ω	1
	R2	ERJ6GEYJ330V	33 Ω	1
	R3	ERJ6GEYJ680V	68 Ω	1
	R4	ERJ6GEYJ102V	1K Ω	1
	R5	ERJ6GEYJ151V	150 Ω	1

Ref. No.	Part No.	Description	P/S	
	R6	ERJ6GEYJ331V	330 Ω	1
	R7	ERJ6GEYJ224V	220K Ω	1
	R8	ERJ6GEYJ104V	100K Ω	1
	R9	ERJ6GEYJ103V	10K Ω	1
	R10	ERJ6GEYJ102V	1K Ω	1
	R11	ERJ6GEYJ680V	68 Ω	1
	R12	ERJ6GEYJ104V	100K Ω	1
	R13, 14	ERJ6GEYJ103V	10K Ω	2
	R15, 16	ERJ6GEYJ102V	1K Ω	2
	R18	ERJ6GEYJ221V	220 Ω	1
	R19	ERJ6GEYJ102V	1K Ω	1
	R20	ERJ6GEYJ104V	100K Ω	1
	R21	ERJ6GEYJ221V	220 Ω	1
	R22	ERJ6GEYJ103V	10K Ω	1
	R23~25	ERJ6GEYJ101V	100 Ω	3
	R26	ERJ6GEYJ102V	1K Ω	1
	R28, 29	ERJ6GEYJ221V	220 Ω	2
	R30	ERJ6GEYJ102V	1K Ω	1
	R31	ERJ6GEYJ221V	220 Ω	1
	R33	ERJ6GEYJ104V	100 Ω	1
	R34	ERJ6GEYJ102V	1K Ω	1
	R35	ERJ6GEYJ222V	2.2K Ω	1
	R36	ERJ6GEYJ102V	1K Ω	1
	R37	ERJ6GEYJ474V	470K Ω	1
	R38	ERJ6GEYJ221V	220 Ω	1
	R39~42	ERJ6GEYJ472V	4.7K Ω	4
	R43, 44	ERJ6GEYJ103V	10K Ω	2
	R45, 46	ERJ6GEYJ472V	4.7K Ω	2
	R47~49	ERJ6GEYJ221V	220 Ω	3
	R50	ERJ6GEYJ333V	33K Ω	1
	R51	ERJ6GEYJ473V	47K Ω	1
	R52	ERJ6GEYJ221V	220 Ω	1
	R53	ERJ6GEYJ104V	100K Ω	1
	R54	ERJ6GEYJ103V	10K Ω	1
	R55	ERJ6GEYJ682V	68K Ω	1
	R56	ERJ6GEYJ102V	1K Ω	1
	R57~61	ERJ6GEYJ103V	10K Ω	5
	R62	ERJ6GEYJ102V	1K Ω	1
	R63	ERJ6GEYJ151V	150 Ω	1
	R64, 65	ERJ6GEY0R00V	0 Ω	2
	R67	ERJ6GEYJ221V	220 Ω	1
	R68	ERJ6GEYJ330V	33 Ω	1
	R69, 70	ERJ6GEYJ680V	68 Ω	2
	R71	ERJ6GEYJ151V	150 Ω	1
	R72	ERJ6GEYJ331V	330 Ω	1
	R73	ERJ6GEYJ224V	220K Ω	1
	R74	ERJ6GEYJ102V	1K Ω	1
	R75	ERJ6GEYJ104V	100K Ω	1
	R76	ERJ6GEYJ103V	10K Ω	1
	R77	ERJ6GEYJ221V	220 Ω	1
	R78	ERJ6GEYJ104V	100K Ω	1
	R79	ERJ6GEYJ472V	4.7K Ω	1
	R81	ERG1SJ331	330 Ω , 1W, Flame Type	1
	R82	ERJ6GEYJ331V	330 Ω	1
	R83	ERJ6GEYJ101V	100 Ω	1
	R84	ERJ6GEYJ221V	220 Ω	1
	R85	ERJ6GEYJ471V	470 Ω	1
	R86	ERJ6GEYJ683V	68K Ω	1
	R87	ERJ6GEYJ221V	220 Ω	1
	R88	ERJ6GEYJ472V	4.7K Ω	1
	R89	ERJ6GEYJ221V	220 Ω	1
	R90, 91	ERJ6GEYJ122V	THICK FILM CHIP RESISTOR, 1/10W	2
	R92	ERJ6GEYF102V	THICK FILM CHIP RESISTOR, 1/10W	1
	R93	ERJ6GEYJ101V	100 Ω	1
	R94	ERJ6GEYJ152V	1.5K Ω	1
	R95~97	ERJ6GEYJ101V	100 Ω	3
	R98	ERJ6GEYJ472V	4.7K Ω	1
	R99	ERJ6GEYJ221V	220 Ω	1

Ref. No.	Part No.	Description	P/S
DIODES			
D1~14	MA110	DIODE	14
D15	MA8082M	DIODE, SI	1
D16	MA8056L	DIODE, SI	1
D17	△ SVDGERC9102	DIODE	1
D18	△ MA2062LF	ZENER, 6.2V	1
D19	MA151WK	DIODE	1
D20, 21	MA110	DIODE	2
D22	MA151WK	DIODE	1
D25, 26	MA110	DIODE	2
D27	EK04	DIODE	1
D28	MA8030L	ZENER, 3.1V	1
D29	MA110	DIODE	1
D30, 31	MA1062M	ZENER, 6.2V	2
D32, 33	MA110	DIODE	2
D34, 35	MA121	DIODE, SI, 100mA	2
D36	MA159A	DIODE, SI, 100mA	1
OSCILLATORS			
X1	QSXG2F2800A	CERAMIC OSCILLATOR	1
X2	EF0EC8004A5	8MHz, CERAMIC OSCILLATOR	1
X3	QSXG1A2500A	25MHz, QUARTZ OSCILLATOR	1
X4	QSXG1I3386A	CRYSTAL OSCILLATOR	1
X5	QSXG2F2400A	CERAMIC OSCILLATOR	1
COMPONENT COMBINATIONS			
Z1~4	EXBS8V103J	10KΩ × 4	4
Z5	EXBV8V221J	220Ω × 4	1
Z6	EXBV8V102J	1KΩ × 4	1
Z7	EXBS8V102J	1KΩ × 4	1
Z10~13	EXBS8V103J	10KΩ × 4	4
Z14	EXBS8V221J	220Ω × 4	1
Z15, 16	EXBV8V472J	4.7KΩ × 4	2
Z17	EXBS8VR000	0Ω × 4	1
Z18~24	EXBV8V470J	47Ω × 4	7
Z25, 26	EXBS8V470J	47Ω × 4	2
Z27~29	EXBV8V102J	1KΩ × 4	3
Z30~36	EXBV8V470J	47Ω × 4	7
Z37~47	EXBV8V471J	470Ω × 4	11
Z48	EXBV8V102J	1KΩ × 4	1
Z49	EXBV8V471J	470Ω × 4	1
Z50, 51	EXBS8V103J	10KΩ × 4	2
Z52~55	EXBV8V221J	220Ω × 4	4
COILS			
L1~7	QLQGT3T150SA	15μH × 3	7
L8	SLCG3A121T	120μH	1
L9	QLBG002A	0.45μH	1
L10	QLQGT1B800MA	80μH	1
JACKS			
JK1~3	QJJG005AA	JACK SOCKET	3
JK4, 5	QJJG003AA	JACK	2
JK6, 7	SJJG100A	JACK	2
JK8~11	QJJG003AA	JACK	4
RESISTORS			
R1	ERJ6GEYJ221V	220Ω	1
R2	ERJ6GEYJ330V	33Ω	1
R3	ERJ6GEYJ680V	68Ω	1
R4	ERJ6GEYJ102V	1KΩ	1
R5	ERJ6GEYJ151V	150Ω	1

Ref. No.	Part No.	Description	P/S
R6	ERJ6GEYJ331V	330Ω	1
R7	ERJ6GEYJ224V	220KΩ	1
R8	ERJ6GEYJ104V	100KΩ	1
R9	ERJ6GEYJ103V	10KΩ	1
R10	ERJ6GEYJ102V	1KΩ	1
R11	ERJ6GEYJ680V	68Ω	1
R12	ERJ6GEYJ104V	100KΩ	1
R13, 14	ERJ6GEYJ103V	10KΩ	2
R15, 16	ERJ6GEYJ102V	1KΩ	2
R18	ERJ6GEYJ221V	220Ω	1
R19	ERJ6GEYJ102V	1KΩ	1
R20	ERJ6GEYJ104V	100KΩ	1
R21	ERJ6GEYJ221V	220Ω	1
R22	ERJ6GEYJ103V	10KΩ	1
R23~25	ERJ6GEYJ101V	100Ω	3
R26	ERJ6GEYJ102V	1KΩ	1
R28, 29	ERJ6GEYJ221V	220Ω	2
R30	ERJ6GEYJ102V	1KΩ	1
R31	ERJ6GEYJ221V	220Ω	1
R33	ERJ6GEYJ104V	100Ω	1
R34	ERJ6GEYJ102V	1KΩ	1
R35	ERJ6GEYJ222V	2.2KΩ	1
R36	ERJ6GEYJ102V	1KΩ	1
R37	ERJ6GEYJ474V	470KΩ	1
R38	ERJ6GEYJ221V	220Ω	1
R39~42	ERJ6GEYJ472V	4.7KΩ	4
R43, 44	ERJ6GEYJ103V	10KΩ	2
R45, 46	ERJ6GEYJ472V	4.7KΩ	2
R47~49	ERJ6GEYJ221V	220Ω	3
R50	ERJ6GEYJ333V	33KΩ	1
R51	ERJ6GEYJ473V	47KΩ	1
R52	ERJ6GEYJ221V	220Ω	1
R53	ERJ6GEYJ104V	100KΩ	1
R54	ERJ6GEYJ103V	10KΩ	1
R55	ERJ6GEYJ682V	6.8KΩ	1
R56	ERJ6GEYJ102V	1KΩ	1
R57~61	ERJ6GEYJ103V	10KΩ	5
R62	ERJ6GEYJ102V	1KΩ	1
R63	ERJ6GEYJ151V	150Ω	1
R64, 65	ERJ6GEY0R00V	0Ω	2
R67	ERJ6GEYJ221V	220Ω	1
R68	ERJ6GEYJ330V	33Ω	1
R69, 70	ERJ6GEYJ680V	68Ω	2
R71	ERJ6GEYJ151V	150Ω	1
R72	ERJ6GEYJ331V	330Ω	1
R73	ERJ6GEYJ224V	220KΩ	1
R74	ERJ6GEYJ102V	1KΩ	1
R75	ERJ6GEYJ104V	100KΩ	1
R76	ERJ6GEYJ103V	10KΩ	1
R77	ERJ6GEYJ221V	220Ω	1
R78	ERJ6GEYJ104V	100KΩ	1
R79	ERJ6GEYJ472V	4.7KΩ	1
R81	ERG1SJ331	330Ω, 1W, Flame Type	1
R82	ERJ6GEYJ331V	330Ω	1
R83	ERJ6GEYJ101V	100Ω	1
R84	ERJ6GEYJ221V	220Ω	1
R85	ERJ6GEYJ471V	470Ω	1
R86	ERJ6GEYJ683V	68KΩ	1
R87	ERJ6GEYJ221V	220Ω	1
R88	ERJ6GEYJ472V	4.7KΩ	1
R89	ERJ6GEYJ221V	220Ω	1
R90, 91	ERJ6GEYJ122V	THICK FILM CHIP RESISTOR, 1/10W	2
R92	ERJ6GEYF102V	THICK FILM CHIP RESISTOR, 1/10W	1
R93	ERJ6GEYJ101V	100Ω	1
R94	ERJ6GEYJ152V	1.5KΩ	1
R95~97	ERJ6GEYJ101V	100Ω	3
R98	ERJ6GEYJ472V	4.7KΩ	1
R99	ERJ6GEYJ221V	220Ω	1

Ref. No.	Part No.	Description	P/S
R100	ERJ6GEYJ102V	1KΩ	1
R101	ERJ6GEYJ104V	100KΩ	1
R102	ERJ6GEYJ101V	100Ω	1
R103	ERJ6GEYJ221V	220Ω	1
R104~107	ERJ6GEYJ102V	1KΩ	4
R108~110	ERJ6GEYJ221V	220Ω	3
R111	ERJ6GEYJ101V	100Ω	1
R112	ERJ6GEYJ471V	470Ω	1
R113	ERJ6GEYJ221V	220Ω	1
R114, 115	ERJ6GEYJ471V	470Ω	2
R116~118	ERJ6GEYJ103V	10KΩ	3
R119	ERJ6GEYJ682V	6.8KΩ	1
R120	ERJ6GEYJ104V	100KΩ	1
R121	ERJ6GEYJ124V	120KΩ	1
R122	ERJ6GEYJ330V	33Ω	1
R123	ERJ6GEYJ102V	1KΩ	1
R124	ERJ6GEYJ682V	6.8KΩ	1
R125	ERJ6GEYJ104V	100KΩ	1
R126	ERJ6GEYJ124V	120KΩ	1
R127	ERJ6GEYJ330V	33Ω	1
R128	ERJ6GEYJ102V	1KΩ	1
R129, 130	△ ERG1SJ330	33Ω, 1W	2
R131, 132	ERJ6GEYJ681V	680Ω	2
R133, 134	ERJ6GEYJ103V	10KΩ	2
R135	ERJ6GEYJ682V	6.8KΩ	1
R136	ERJ6GEYJ105V	1MΩ	1
R137	ERJ6GEYJ104V	100KΩ	1
R138	ERJ6GEYJ124V	120KΩ	1
R139	ERJ6GEYJ681V	680Ω	1
R140	ERJ6GEYJ103V	10KΩ	1
R141	ERJ6GEYJ682V	6.8KΩ	1
R142, 143	ERJ6GEYJ104V	100KΩ	2
R144	ERJ6GEYJ124V	120KΩ	1
R145	ERJ6GEYJ681V	680Ω	1
R146	ERJ6GEYJ104V	100KΩ	1
R147, 148	ERJ6GEYJ152V	1.5KΩ	2
R149, 150	ERJ6GEYJ102V	1KΩ	2
R151~155	ERJ6GEY0R00V	0Ω	5
R156	ERJ6GEYJ102V	1KΩ	1
R157	ERJ6GEYJ471V	470Ω	1
R158~160	ERJ6GEYJ470V	47Ω	3
R161	ERJ6GEYJ103V	10KΩ	1
R162~164	ERJ6GEYJ102V	1KΩ	3
R165	ERJ6GEYJ470V	47Ω	1
R166, 167	ERJ6GEYJ102V	1KΩ	2
R168	ERJ6GEYJ103V	10KΩ	1
R169, 170	ERJ6GEYJ102V	1KΩ	2
R171, 172	ERJ6GEYJ471V	470Ω	2
R173, 174	ERJ6GEYJ104V	100KΩ	2
R175	ERJ6GEYJ102V	1KΩ	1
R176	ERJ6GEYJ471V	470Ω	1
R177, 178	ERJ6GEYJ103V	10KΩ	2
R179~183	ERJ6GEYJ102V	1KΩ	5
R184	ERJ6GEYJ471V	470Ω	1
R186, 187	ERJ6GEYJ221V	220Ω	2
R188	ERJ6GEYJ471V	470Ω	1
R189	ERJ6GEYJ102V	1KΩ	1
R190, 191	ERJ6GEYJ221V	220Ω	2
R192	ERJ6GEYJ471V	470Ω	1
R200~210	ERJ6GEY0R00V	0Ω	11
CAPACITORS			
C1~8	ECUV1H104ZFX	0.1μF	8
C9	ECUV1H332KB	0.0033μF	1
C10~29, 31~34, 36	ECUV1H104ZFX	0.1μF	25

Ref. No.	Part No.	Description	P/S
C37	ECUV1H333KBX	0.033μF	1
C39	ECUV1H221JG	220pF	1
C43~49	ECUV1H104ZFX	0.1μF	7
C50	ECUV1E224ZFX	0.22μF	1
C51~54	ECUV1H104ZFX	0.1μF	4
C55, 56	ECRF1H104ZF	0.1μF	2
C57	ECQV1H104JM	0.1μF	1
C58	ECRF1H104ZF	0.1μF	1
C59~62	ECUV1H104ZFX	0.1μF	4
C63, 64	ECUV1H101JG	100pF	2
C65	ECUV1H333KBX	0.033μF	1
C66~69	ECUV1H104ZFX	0.1μF	4
C70	ECUV1H103KGB	0.01μF	1
C71	ECUV1H104ZFX	0.1μF	1
C72	ECUV1C104KCB	CERAMIC CAPACITOR, MULTI LAYER	1
C73, 74	ECUV1H100DCN	10pF	2
C75~77	ECUV1H104ZFX	0.1μF	3
C78, 79	ECUV1H100DCN	10pF	2
C80	ECUV1H104ZFX	0.1μF	1
C83	ECUV1H333KBX	0.033μF	1
C84	ECUV1H104ZFX	0.1μF	1
C85	ECUV1H472KGB	0.0047μF	1
C86	ECUV1H223KBX	0.022μF	1
C87	ECUV1H182JX	MULTILAYER CERAMIC CHIP CAPACITOR	1
C88	ECEA1HKA010	1μF, 50V	1
C89, 90	ECUV1H104ZFX	0.1μF	2
C91	ECQV1H104JM	0.1μF	1
C92, 93	ECUV1H221JG	220pF	2
C94~98	ECUV1H104ZFX	0.1μF	5
C99	ECEA1CKA101	100μF, 16V	1
C101	ECUV1H104ZFX	0.1μF	1
C102~104	ECRF1H104ZF	0.1μF	3
C105	ECUV1H104ZFX	0.1μF	1
C107	ECEA1CKA100	10μF, 16V	1
C109	ECUV1H103KGB	0.01μF	1
C110	ECEA0JU102	1000μF, 6.3V	1
C111~113	ECUV1H104ZFX	0.1μF	3
C114	ECEA0JKA470	47μF, 6.3V	1
C115	EECS5R5V105	1F, 5.5V, MEMORY BACK-UP	1
C116	ECEA1CKA100	10μF, 16V	1
C117	EECS5R5V105	1F, 5.5V, MEMORY BACK-UP	1
C118~126	ECUV1H104ZFX	0.1μF	9
C127, 128	ECUV1H060DCN	6pF	2
C129~143	ECUV1H104ZFX	0.1μF	15
C144	ECCR1H470J	47pF	1
C145	ECUV1H104ZFX	0.1μF	1
C146	ECEA0JU102	1000μF, 6.3V	1
C147~149	ECUV1H104ZFX	0.1μF	3
C150	ECEA0JKA470	47μF, 6.3V	1
C151	ECUV1H102JX	0.001μF	1
C152	ECUV1H100DCN	10pF	1
C153~156	ECUV1H104ZFX	0.1μF	4
C157, 158	ECRF1H104ZF	0.1μF	2
C159	ECUV1H102JX	0.001μF	1
C160	ECUV1H470JG	47pF	1
C161	ERJ6GEY0R00V	0Ω	1</

Ref. No.	Part No.	Description	P/S
C187	ECUV1H220JCN	22pF	1
C188	ECUV1C224KBX	CERAMIC CAPACITOR, MULTI LAYER	1
C189	ECQV1H104JM	0.1μF	1
C190	ECUV1H101JG	100pF	1
C191, 192	ECEA1CKN100	10μF, 16V	2
C193	ECUV1H104ZFX	0.1μF	1
C194	ECUV1H221JG	220pF	1
C195, 196	ECUV1H104ZFX	0.1μF	2
C198, 199	ECUV1H221JG	220pF	2
C200	ECUV1H470JG	47pF	1
C201~212	ECUV1H104ZFX	0.1μF	12
C213, 214	ECUV1E224ZFX	0.22μF	2
C215	ECUV1H104ZFX	0.1μF	1
C216~219	ECEA1HKN010	1μF, 50V	4
C220	ECUV1H101JG	100pF	1
C221	ECEA1EKA100	10μF, 25V	1
C222~225, 227, 228	ECUV1H104ZFX	0.1μF	6
C229~231	ECUV1H100DCN	10pF	3

Ref. No.	Part No.	Description	P/S
LINE FILTER			
L1	△ SLTGLF3	LINE FILTER	1
FUSES			
F1	△ XBA1C16NU100	1.6A, 125V, M MC XM	1
F1	△ XBA2C10TB0	T1.0A, 250V, X XR XS XD XT	1
F2	△ XBA2C05TB0	T500mA, 250V, EN EK EZ EW EF EA EH EP XL XP X XR XS XD XT	1
F3	△ XBA2C20TB0	T2A, 250V, EN EK EZ EW EF EA EH EP XL XP X XR XS XD XT	1
F3	△ XBA1C25NU100	2.5A, 125V, M MC XM	1
RESISTORS			
R1, 2	ERDS2TJ103	10kΩ	2
R3	△ ERD2FCVJ4R7	4.7Ω, 1/4W, FUSE TYPE	1
R4	ERDS2TJ471	470Ω	1
R5	△ ERX2ANJPR22S	0.22Ω, 2W, FLAME-PROOF	1
R6	△ ERQ1CJP220S	FUSE RESISTOR, 1W	1
R7~9	△ ERD2FCVJ4R7	4.7Ω, 1/4W, FUSE TYPE	3
CAPACITORS			
C1	△ ECKCVA1472MF	4700pF, LINE CAPACITOR	1
C2,	△ ECQU2A104MT	0.1μF, 250V, ACROSS-THE LINE CAPACITOR	1
C3	△ ECQE1A104M6	0.1μF, 125V	1
C4	△ ECEA1EU222	2200μF, 25V	1
C5	ECA1EM682E	6800μF, 25V	1
C6	ECEA1VKA100	10μF, 35V	1
C7	ECEA1VKA330	33μF, 35V	1
C8	ECEA1EU101	100μF, 25V	1
C9, 10	ECA1EM331	ALUMINIUM CAPACITOR	2

MB1 MODULATION BALL 1 CIRCUIT

Ref. No.	Part No.	Description	P/S
VARIABLE RESISTOR			
○ VR1	QRVG41B01B54	VARIABLE RESISTOR	1

MB2 MODULATION BALL 2 CIRCUIT

Ref. No.	Part No.	Description	P/S
VARIABLE RESISTOR			
○ VR2	QRVG22B01B54	VARIABLE RESISTOR	1

ACP AC POWER SUPPLY CIRCUIT

Ref. No.	Part No.	Description	P/S
DIODES			
D1~4	△ SVDS3V20	RECTIFIER	4
D5~8	△ SVDGERA1502	RECTIFIER	4
D9	MA4220M	ZENER, 22V	1

INV INVERTER CIRCUIT

Ref. No.	Part No.	Description	P/S
TRANSISTORS			
Q1, 2	2SC3940ARS	TRANSISTOR	2
TRANSFORMER			
T1	△ QTDG003A	TRANSFORMER	1
IC PROTECTOR			
IP1	△ ICP-N10T104	IC PROTECTOR	1
RESISTORS			
R1, 2	ERDS2TJ562	5.6kΩ	2

CPR CONTROL PANEL RIGHT CIRCUIT

Ref. No.	Part No.	Description	P/S
CAPACITORS			
C1	ECEA0JKA101	100μF, 6.3V	1
C2	ECRF1H104ZF	0.1μF	1
S C3, 4	△ ECCD3F180JGE	18pF	2
C5	ECHS1473JZW	0.047μF	1

Ref. No.	Part No.	Description	P/S
DIODES			
D1~24	MA165	DIODE	24
D100~115, 120~123	SEL2210SM	LED (RED)	20
○ D116~119	SEL2410E	LED, SI	4
D152	LN282R	LED (RED)	1
SWITCHES			
S1~24	EVQ21507K	PUSH SWITCH	24

CPC CONTROL PANEL CENTER CIRCUIT

Ref. No.	Part No.	Description	P/S
INTEGRATED CIRCUITS			
IC2, 3	HD74LS07P	HEX BUFFERS	2
TRANSISTORS			
Q1~3, 5, 6	2SA830SB	TRANSISTOR	5
DIODES			
D25~70, 73~88	MA165	DIODE	62
D132~137, 164	SEL2210SM	LED (RED)	7
○ D140~145	SEL2410E	LED, SI	6
D146	SEL6210S	LED (RED)	1
D147	SEL6410E	LED (GREEN)	1
OSCILLATOR			
X1	EF0EC4004A3	4MHz, CERAMIC OSCILLATOR	1
SWITCHES			
ESW1	QSRGT002AA	ENCODER SWITCH	1
S25~70, 73~88	EVQ21507K	PUSH SWITCH	62
IC PROTECTOR			
IP1	△ ICP-N10T104	IC PROTECTOR	1
VARIABLE RESISTOR			
VR2	QRVG20N01B14	10kΩ B	1
RESISTORS			
R1~11	ERDS2TJ680	68Ω	11
R12~14, 16~25	ERDS2TJ103	10kΩ	13
R26	ERDS2TJ333	33kΩ	1
R27, 28	ERDS2TJ101	100Ω	2
R29, 30	ERDS2TJ472	4.7kΩ	2
R31, 32	ERDS2TJ473	47kΩ	2
R33~37	ERDS2TJ102	1kΩ	5
CAPACITORS			
C1~3	ECRF1H104ZF	0.1μF	3
C4	ECEA0JKA221	220μF, 6.3V	1
C5	ECQB1H223JF	0.022μF	1
C6	ECEA0JKA470	47μF, 6.3V	1
C7, 8	ECQG1H102KZ	0.001μF	2
C9~12	ECRF1H104ZF	0.1μF	4

CPL CONTROL PANEL LEFT CIRCUIT

Ref. No.	Part No.	Description	P/S
DIODES			
D71	MA165	DIODE	1
D138, 139, 160, 161	LN282R	LED (RED)	4
SWITCH			
S71	EVQ21507K	PUSH SWITCH	1
VARIABLE RESISTOR			
○ VR1	QRVG30N02B24	VARIABLE RESISTOR, 0.2W	1

MOD1 MODULATION 1 CIRCUIT

Ref. No.	Part No.	Description	P/S
VARIABLE RESISTOR			
VR1	QRVG16A02B54	50kΩ, B	1

MOD2 MODULATION 2 CIRCUIT

Ref. No.	Part No.	Description	P/S
VARIABLE RESISTOR			
○ VR1	QRVG16E01B54	VARIABLE RESISTOR, 0.05W	1
RESISTORS			
R1, 2	ER0S2CKF1001	1kΩ, ±1%	2

BEND PITCH BEND CIRCUIT

Ref. No.	Part No.	Description	P/S
VARIABLE RESISTOR			
VR1	QRVG16A02B54	50k Ω , B	1
RESISTORS			
R1, 2	ER0S2CKF1001	1k Ω , \pm 1%	2

MKB1 MANUAL KEYBOARD 1 CIRCUIT

Ref. No.	Part No.	Description	P/S
DIODES			
D1~48	MA165	DIODE	48

MKB2 MANUAL KEYBOARD 2 CIRCUIT

Ref. No.	Part No.	Description	P/S
INTEGRATED CIRCUITS			
IC1, 2	HD74LS138P	3 TO 8 DECODER	2
IC3	M5218AL	OPERATIONAL AMPLIFIER	1
IC4	ST93C46CB1	1M BIT PROGRAMMED EEPROM	1
DIODES			
D49~122	MA165	DIODE	74
VARIABLE RESISTOR			
VR1	EVSG0E1B223A	22k Ω B	1
RESISTORS			
R1	ERDS2TJ102	1k Ω	1
R2	ERDS2TJ472	4.7k Ω	1
R3	ERDS2TJ222	2.2k Ω	1
R4	ERDS2TJ472	4.7k Ω	1
CAPACITORS			
C1, 2	ECRF1H104ZF	0.1 μ F	2
C3	ECEA0JKA470	47 μ F, 6.3V	1
C4, 5	ECRF1H104ZF	0.1 μ F	2

WIRING PARTS

Ref. No.	Part No.	Description	P/S
○ W1	△ QEXGVH03020B	COMMU CABLE W/OUT PLUG	1
○ W2	△ QEXGVH04010B	COMMU CABLE W/OUT PLUG	1
○ W3	△ QEXGSS06035A	COMMU CABLE W/OUT PLUG	1
○ W4	△ QEXGSS05075A	COMMU CABLE W/OUT PLUG	1
○ W5	△ QEXGSS08025A	CONNECTOR WITH WIRE	1
○ W6	△ QEXGSS04025A	COMMU CABLE W/OUT PLUG	1
○ W7	△ QEXGSS16065A	CONNECTOR WITH WIRE	1
○ W8	△ QEXGSS04065A	COMMU CABLE W/OUT PLUG	1
○ W9	△ QEXGSS05065A	COMMU CABLE W/OUT PLUG	1
○ W10	△ QEXGZA34065A	COMMU CABLE W/OUT PLUG	1
○ W11	△ QEXGSS06030A	COMMU CABLE W/OUT PLUG	1
○ W12	△ QEXGSS06010A	COMMU CABLE W/OUT PLUG	1
○ W13	△ QEXGSS05020A	CONNECTOR WITH WIRE	1
○ W14	△ QEXGVH07020B	COMMU CABLE W/OUT PLUG,	1

X XR XS XD XT

CABINET PARTS LOCATION (A)

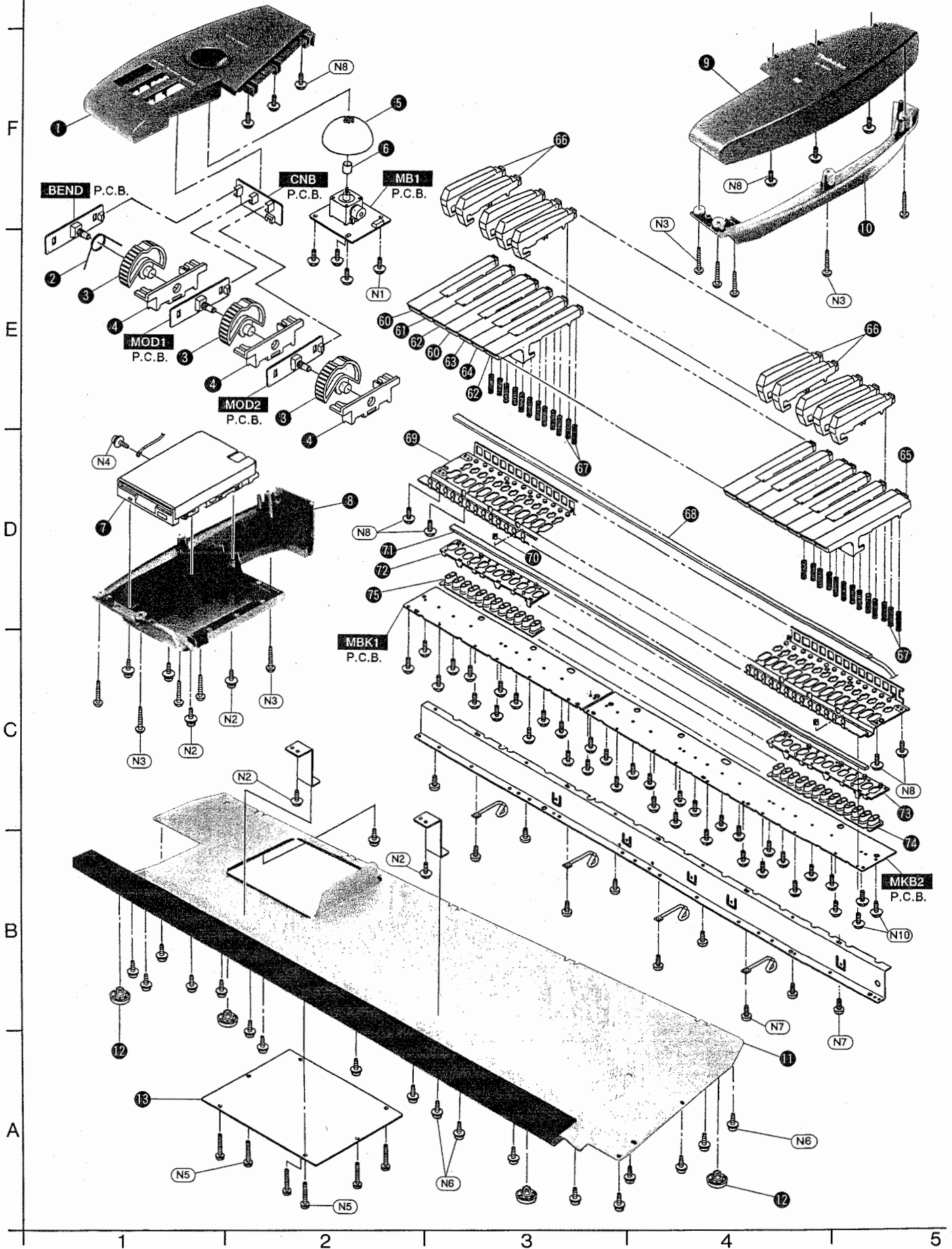

CABINET PARTS LOCATION (B)

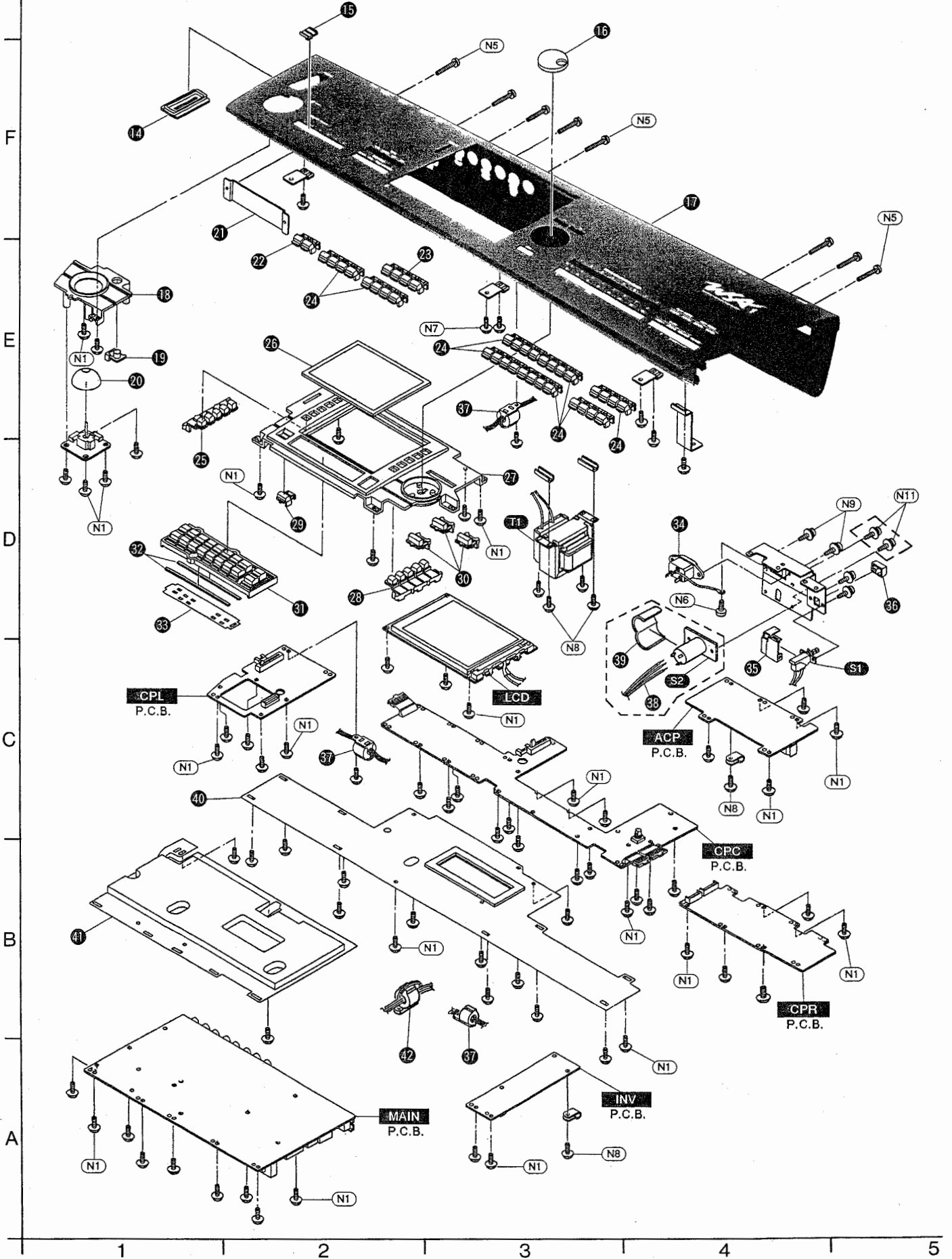

REPLACEMENT PARTS LIST.....Cabinet and Chassis Parts

Notes:

- The marking (RTL) indicates that the Retention Time is limited for this item. After the discontinuation of this assembly in production, the item will continue to be available for a specific period of time. The retention period of availability is dependant on the type of assembly, and in accordance with the laws governing part and product retention.
After the end of this period, the assembly will no longer be available.
- mark are new parts.

- Important safety notice
Components identified by △ mark have special characteristics important for safety. When replacing any of these components, use only manufacturer's specified parts.
- For part No. with area mark, check the area when placing an order.
- The raw material indication for synthetic resin
In order to facilitate classification of parts of synthetic resin manufacture and to promote the recycling of natural resources, a raw material symbol for such parts is indicated in the Ref. No./Material column.

CABINET & CHASSIS PARTS

Ref. No.	Part No.	Description	P/S	Ref. No.	Part No.	Description	P/S
SWITCHES							
S1	△ ESB8273V	POWER SWITCH	1				
S2	△ ESE37209	VOLTAGE SELECTOR, X XR XS XD XT	1				
TRANSFORMER							
○ T1	△ QTPG1M036A	POWER TRANSFORMER, EN EK EZ EW EF EA EH EP XL XP	1				
○ T1	△ QTPG1M035A	POWER TRANSFORMER, M MC XM	1				
○ T1	△ QTPG1M037A	POWER TRANSFORMER, X XR XS XD XT	1				
POWER CORD & PLUG							
○ PC1	△ QJAG018AA	POWER CORD W/PLUG, 240V, EN EZ EF EA EH EP X XS XD XT XP	1				
○ PC1	△ QJAG020AA	POWER CORD W/PLUG, 240V, EK	1				
○ PC1	△ QJAG021AA	POWER CORD W/PLUG, 240V, EW	1				
○ PC1	△ QJAG019AA	POWER CORD W/PLUG, 240V, XL XR	1				
PC1	△ SJAG44	POWER CORD W/PLUG, 120V, M MC XM	1				
PC2	△ SJP5213-1	ATTACHMENT PLUG, X XT XP	1				
CABINET PARTS							
○ 1	PS QGPG0103AB	LEFT UPPER PANEL	1	○ 17	QGPG0105BA	CENTER PANEL, EN M MG EK EZ EW EF EA EH EP XL XM XP	1
2	SUSG570A	SPRING	1	○ 17	QGPG0105AA	CENTER PANEL, X XR XS XD XT	1
○ 3	ABS QGUG3006AA	WHEEL	3	○ 18	PS QGKG0123AA	ORNAMENT, PS	1
4	PS QMQG0016AA	BENDER CASE	3	○ 19	ABS QGUG1416AA	PUSH BUTTON	1
○ 5	ABS QGUG3007AA	BALL	1	○ 20	ABS QGUG3008AA	BALL	1
○ 6	QWZG006AA	RECEIVING TUBE	1	○ 21	QGKG0126AA	LID	1
7	△ QAU012AA	DDR DRIVE UNIT	1	○ 22	ABS QGUG1415CA	PUSH BUTTON	1
○ 8	PS QKSGK014AB	LEFT LOWER PANEL	1	○ 23	ABS QGUG1415BA	PUSH BUTTON	1
○ 9	PS QGPG0102AB	RIGHT UPPER PANEL	1	○ 24	ABS QGUG1415AA	PUSH BUTTON	8
○ 10	PS QKSGK013AB	RIGHT LOWER PANEL	1	○ 25	ABS QGUG1418AA	PUSH BUTTON	1
○ 11	QKSGK015AA	BOTTOM PANEL	1	○ 26	QKWG023AA	PLATE	1
12	SHRG2200A	LEG	4	○ 27	PS QGPG0104AB	ORNAMENT, PS	1
○ 13	QMAG0152BA	LID	1	○ 28	ABS QGUG1419AA	PUSH BUTTON	1
○ 14	PS QMRG7067AA	ORNAMENT, PS	1	○ 29	ABS QGUG1415DA	PUSH BUTTON	1
○ 15	ABS QGUG2002AA	KNOB	1	○ 30	ABS QGUG1417AA	PUSH BUTTON	3
16	ABS QGUG3002BB	DIAL WHEEL	1	○ 31	ABS QGUG1420AA	PUSH BUTTON	1
				○ 32	QMG045AA	SPACER	2
				○ 33	QMFG4172AA	FELT	1
				34	△ SJSJG460A	PLUG	1
				35	SHRG8390A	COVER, POWER SW	1
				36	SBCG110B	BUTTON, POWER SWITCH	1
				37	△ QLZG005A	CORE	3
				○ 38	△ QEXGVH07020B	COMMU CABLE W/OUT PLUG, X XR XS XD XT	1
				39	SUV453	SWITCH COVER, X XR XS XD XT	1
				○ 40	QSCG082A	MAGNETIC SHIELD	1
				○ 41	QSCG090A	MAGNETIC SHIELD	1
				42	△ QLZG006A	CORE	1
				○ 60	QMWG1033AA	WHITE KEY (C & F KEY)	10
				○ 61	QMWG1034AA	WHITE KEY (D KEY)	5
				○ 62	QMWG1035AA	WHITE KEY (E & B KEY)	10
				○ 63	QMWG1036AA	WHITE KEY (G KEY)	5
				○ 64	QMWG1037AA	WHITE KEY (A KEY)	5
				○ 65	QMWG1038AA	WHITE KEY (TOP OCTAVE C KEY)	1
				○ 66	QMWG2005AA	BLACK KEY	25
				67	QMBG007BA	SPRING	61
				○ 68	QMWG5003BA	AFTER SENSOR	1
				○ 69	QMWG3020AA	CHASSIS	1
				70	SHGG9052A	KEY GUIDE RUBBER	61
				71	QMFG1120CA	FELT	1
				72	QMWG8031DA	SPACER (12 PCS. ON ONE)	4
				73	QMWG8030CA	SPACER (13 PCS. ON ONE)	1
				74	QMWG6009BA	RUBBER SWITCH (13 PCS. ON ONE)	1

■ PACKING PARTS

Ref. No.	Part No.	Description	P/S
75	QMWG6010BA	RUBBER SWITCH (12 PCS. ON ONE)	4
SCREWS & WASHERS			
N1	XTW3+8Q	SCREW	81
N2	XYN3+F8FZ	SCREW WITH WASHER	4
N3	XTB3+10GFZ	SCREW	10
N4	XYN3+F6	SCREW WITH WASHER	1
N5	XYA3+DJ14FZ	SCREW W/WASHER	16
N6	XYA4+DJ10FZ	SCREW W/WASHER	19
N7	XTB3+5C	SCREW	12
N8	XTW3+10QFZ	SCREW	22
N9	XYN3+F8FZ	SCREW WITH WASHER	4
N10	XTW3+10T	SCREW	37
N11	XYN3+F8FZ	SCREW, X XR XS XD XT	2

Ref. No.	Part No.	Description	P/S
PACKING PARTS			
1	QPGG0328AA	CUSHION, PAPER	1
2	<input type="checkbox"/> PS QPNG0533AA	PAD, PS	1
3	<input type="checkbox"/> PS QPNG0534AA	PAD, PS	1
4	QPNG0569AA	PAD	1
5	QPGG0327AA	PACKING CASE, PAPER	1
6	<input type="checkbox"/> PE QPFG002AA	POLYETHYLENE BAG	1
8	QFVG2013A	DEMO DISK	1
OPERATING INSTRUCTION MANUAL			
7	QQFGWSA1AA	OPERATING INSTRUCTION MANUAL, EN	1
7-1	{ QQTG0359A	DANSK	1
7-2	{ QQTG0360A	ENGLISH	1
7-3	{ QQTG0361A	ENGLISH	1
7	QQFGWSA1CA	OPERATING INSTRUCTION MANUAL, M	1
7-1	{ QQTG0364A	ENGLISH	1
7-2	{ QQTG0365A	ENGLISH	1
7	QQFGWSA1DA	OPERATING INSTRUCTION MANUAL, MC	1
7-1	{ QQTG0360A	ENGLISH	1
7-2	{ QQTG0366A	FRANCAIS	1
7-3	{ QQTG0361A	ENGLISH	1
7-4	{ QQTG0367A	FRANCAIS	1
7	△ QQFGWSA1EA	OPERATING INSTRUCTION MANUAL, EK EP X XS XL XR XM XD XT XP	1
7-1	{ QQTG0360A	ENGLISH	1
7-2	{ QQTG0361A	ENGLISH	1
7	QQFGWSA1FA	OPERATING INSTRUCTION MANUAL, EA	1
7-1	{ QQTG0368A	DEUTSCH	1
7-2	{ QQTG0369A	DEUTSCH	1
7	QQFGWSA1GA	OPERATING INSTRUCTION MANUAL, EW	1
7-1	{ QQTG0366A	FRANCAIS	1
7-2	{ QQTG0368A	DEUTSCH	1
7-3	{ QQTG0367A	FRANCAIS	1
7-4	{ QQTG0369A	DEUTSCH	1
7	QQFGWSA1HA	OPERATING INSTRUCTION MANUAL, EF	1
7-1	{ QQTG0366A	FRANCAIS	1
7-2	{ QQTG0370A	ITALIANO	1
7-3	{ QQTG0367A	FRANCAIS	1
7-4	{ QQTG0361A	ENGLISH	1
7	QQFGWSA1JA	OPERATING INSTRUCTION MANUAL, EH	1
7-1	{ QQTG0368A	DEUTSCH	1
7-2	{ QQTG0371A	NERDERLANDS	1
7-3	{ QQTG0369A	DEUTSCH	1
7-4	{ QQTG0361A	ENGLISH	1
7	QQFGWSA1KA	OPERATING INSTRUCTION MANUAL, EZ	1
7-1	{ QQTG0368A	DEUTSCH	1
7-2	{ QQTG0369A	DEUTSCH	1

PACKING

