



Prophecy

SOLO SYNTHESIZER

Parameter Guide



Multi Oscillator Synthesis System

KORG

Table of Contents

How to use this Parameter Guide	1
1. PERFORMANCE mode	2
2. PERFORMANCE EDITOR DEFINE mode	4
PED-1 [PE1 Definition]	4
PED-2 [PE2 Definition]...PED-4 [PE4 Definition]	5
PED-5 [Initialize]	5
PED-6 [Copy]	5
3. ARPEGGIATOR PATTERN DEFINE mode	7
Arpeggio-1 [Arpeggio Param]	7
Arpeggio-2 [Velocity Param]	8
Arpeggio-3 [Gate Param]	8
Arpeggio-4 [Pattern Copy]	9
Pattern-4 [User Pat Param]	9
Pattern-5 [Step]	10
Pattern-6 [Pattern Copy]	11
4. EDIT mode	12
4-1. OSC Section	12
OSC-cmn1 [Oscillator Set]	12
OSC-cmn2 [Pitch EG Level] Pitch EG	13
OSC-cmn3 [Pitch EG Time] Pitch EG	14
OSC-cmn4 [Pitch EG Ctrl] Pitch EG Keyboard Traking/Velocity Control	15
OSC-cmn5 [Pitch Bend] Pitch Bender/ After Touch Bending	16
OSC-cmn6 [Portamento]	17
OSC-cmn7 OSC Menu	18
Osillator 1, Osillator 2	19
OSC1-1 [Basic Pitch]	19
OSC1-2 [Pitch Modulation]	20
OSC1-3 [Pitch Slope]	21
OSC1-4 [Pitch Mod LFO] - Pitch Modulation LFO	22
OSC2-1 [Basic Pitch] ...OSC2-4 [Pitch Mod LFO]	22
Standard Oscillator	23
OSC1-5 [STD WaveLevel] - OSC Setting	24
OSC1-6 [STD Wave Form] - Wave Form Modulation	25
COMB Filter Oscillator	26
OSC1-5 [COMB Input]	27
OSC1-6 [COMB Feedback]	28
OSC1-7 [COMB Loop LPF Frequency]	29
VPM Oscillator	30
OSC1-5 [VPM Carrier Wave]	30
OSC1-6 [VPM Carrier]	31
OSC1-7 [VPM Cari Shape]	32
OSC1-8 [VPM Feedback Gain]	33
OSC1-9 [VPM Modulator Pitch]	33
OSC1-10 [VPM Modulator]	34

OSC1-11 [VPM Modulator Level].....	35
Cross/Sync/Ring Modulation Oscillator	36
OSC2-5 [MOD OSC Type]	38
OSC2-6 [Modulator Cross Modulation]	39
Brass Model Oscillator	40
OSC1-5 [Brass Type]	41
OSC1-6 [Brass Pressure EG]	42
OSC1-7 [Brass Pressure Mod]	43
OSC1-8 [Brass Lip]	44
OSC1-9 [Brass Bell]	45
Reed Model Oscillator	46
OSC1-5 [Reed Type]	46
OSC1-6 [Reed Pressure EG]	47
OSC1-7 [Reed PressureMod] - Reed Pressure Modulation	48
OSC1-8 [Reed Reed Mod]	49
Pluck Oscillator	50
OSC1-5 [Pluck Attack]	50
OSC1-6 [Pluck Noise Filter]	51
OSC1-7 [Pluck Attack Curve]	52
OSC1-8 [Pluck String Position]	53
OSC1-9 [Pluck String Loss]	54
OSC1-10 [Pluck Inharmonicity]	55
OSC1-11 [Pluck Decay & Release]	56
SUB Oscillator	57
SUB OSC-1 [Sub OSC]	57
Noise Generator	58
NOISE-1 [Noise Genrator]	58
[UTY] - Utility	59
OSCU-1 [Initialize]	59
OSCU-2 [Set Initialize]	59
OSCU-3 [COPY]	60
OSCU-4 [Duplicate]	60
OSCU-5 [Swap]	61
4-2. Wave Shape Section	62
WS-1 [WaveShap Menu]	62
[WS1]	63
WS1-1 [Input Gain]	63
WS1-2 [Input Offset]	64
WS1-3 [Feedback & Cross Loop]	65
WS1-4 [Wave Shape]	65
WS1-5 [Output]	67
[WS2]	67
WS2-1 [Input Gain]...WS2-5 [Output]	67
[UTY] - Utility	68
WSU-1 [Initialize]	68
WSU-2 [Copy]	68
WSU-3 [Swap]	69
4-3. Mixer Section	70
MIX-1 [OSC1 fi OUT1]	70
MIX-2 [OSC1 fi OUT2]	71
MIX-3 [OSC2 fi OUT1]	71

MIX-4 [OSC2 fi OUT2]	71
MIX-5 [SUBOSC fi OUT1]	71
MIX-6 [SUBOSC fi OUT2]	71
MIX-7 [NOISE fi OUT1]	72
MIX-8 [NOISE fi OUT2]	72
MIX-9 [Feedback fi OUT1]	72
MIX-10 [Feedback fi OUT2]	72
4-4. Filter Section	73
FLT-1 [Filter Menu]	73
FL1-1 [Type & Input]	74
FL1-2 [Cutoff]	75
FL1-3 [Resonance]	76
FL1-4 [Fc Kbd Trk] Cutoff Frequency Keyboard Track	77
FL1-5 [Fc Modulation]	78
FL2-1 [Type & Input]..FL2-5 [Fc Modulation]	78
[UTY] - Utility	79
FLU-1 [Initialize]	79
FLU-2 [Copy]	80
FLU-3 [Swap]	80
4-5. Amplifier Section	81
AMP-1 [Amp Menu]	81
[AMP1]	82
AMP1-1 [Amplitude] - Amplitude 1	82
AMP1-2 [Amp Modulation]	83
[AMP2]	83
AMP2-1 [Amplitude]..AMP2-2 [Amp Modulation]	83
[AMP EG]	84
AEG-1 [Amp EG Level]	84
AEG-2 [Amp EG Time]	85
AEG-3 [Amp EG KbdTrk] Amplitude EG Keyboard Tracking	86
AEG-4 [Amp EG Velocity] Amplitude EG Velocity Control	87
[UTY] - Utility	88
AMPU-1 [Amp Copy]	88
AMPU-2 [Amp Swap]	88
AMPU-3 [AmpEG Initialize]	89
AMPU-4 [AmpEG Copy]	89
4-6. Effect Section	90
FX-1 [Distortion & Wah]	90
[DIST] - Distortion	91
DIST-1 [Distortion] - Distortion	91
DIST-2 [Fx Balance] - Distortion	92
[WAH] - Wah	93
WAH-1 [Level & Resonance] - Wah	93
WAH-2 [Sweep] - Wah	94
WAH-3 [Fx Balance] - Wah	95
[UTY] - Utility	95
DWU-1 [Initialize]	95
DWU-2 [Copy]	96
FX-2 [Delay/Reverb]	97
[DELAY] - Delay	98

DLY-1 [Delay & Fback] - Delay	98
DLY-2 [Fx Balance] - Delay	99
[CH/FL] - Chorus/Flanger	100
CHFL-1 [Delay & F.Back] - Chorus/Flanger	100
CHFL-2 [Modulation] - Chorus/Flanger	100
CHFL-3 [Fx Balance] - Chorus/Flanger	101
[UTY] - Utility	102
CDU-1 [Initialize]	102
CDU-2 [Copy]	103
[REVERB] - Reverb	104
REV-1 [Reverb Time] - Reverb	104
REV-2 [Fx Balance] - Reverb	105
[UTY] - Utility	107
REUV-1 [Initial]	107
REUV-2 [Copy]	107
FX-3 [Dual Peaking EQ] - 2 Band PEQ	108
[PEQ] - 2 Band Parametric EQ	108
PEQ-1 [High EQ] - 2 Band PEQ	108
PEQ-2 [Low EQ] - 2 Band PEQ	109
[UTY] - Utility	110
EQU-1 [Initialize]	110
EQU-2 [Copy] - 2 Band PEQ Utility	110
4-7. EG (Envelope Generator) Section	111
EG-1 [EG Menu]	111
[EG1]	112
EG1-1 [EG Level]	112
EG1-2 [EG Time]	113
EG1-3 [Time KBD TRK] EG Time Keyboard Tracking	114
EG1-4 [Velocity Control]	115
[EG2] EG2-1..4	116
[EG3] EG3-1..4	116
[EG4] EG4-1..4	116
[UTY] - Utility	116
EGU-1 Initialize	116
EGU-2 Copy	117
EGU-3 Swap	117
4-8. LFO Section	118
LFO-1 [LFO Menu]	118
[LFO1]	119
LFO1-1 [Wave & Mode]	119
LFO1-2 [Frequency]	121
LFO1-3 [Modulation Source]	121
LFO1-4 [Amplitude]	122
[LFO2] LFO2-1..4	123
[LFO3] LFO3-1..4	123
[LFO4] LFO4-1..4	123
[UTY] - Utility	123
LFOU-1 [Copy]	123
LFOU-2 [Swap]	124
4-9. Common Section	125

CMN-1 [Program Name]	125
CMN-2 [Prog Category]-Program Category	126
CMN-3 [Voice Control]	127
CMN-4 [Scale]	128
CMN-5 [Wheel1 /2 Assign]	129
CMN-6 [Wheel3 Assign] - Wheel Controller3 Assign	129
CMN-7 [Ribbon Assign]	130
CMN-8 [Pedal & SW Assign]	131
CMN-9 [Copy Control]	132
CMN-10 [Initialize Program]	132

4-10. Global Section 133

GLB-1 [Tune & Transpose]	133
GLB-2 [Curve & Effects]	134
GLB-3 [User Scale]	135
GLB-4 [Sens&Polar]-Sensitivity & Polarity	136
GLB-5 [Knob Controller Assign]	137
GLB-6 [Arpeggio Controller]	137
GLB-7 [EC5 Function]	138
GLB-8 [MIDI]	139
GLB-9 [MIDI Pitch Bend]	139
GLB-10 [MIDI After Touch]	141
GLB-11 [MIDI Control Change]	142
GLB-12 [MIDI Program Change]	143
GLB-13 [Prog Bank Select Map]	143
GLB-14 [Prog No. Select Map]	144
GLB-15 [SysEX Filter]	144
GLB-16 [Load from Card]	145
GLB-17 [Save to Card]	145
GLB-18 [MIDI Data Dump]	146
GLB-19 [Load Factory Data]	148
GLB-20 [Memory Protect]	148
GLB-21 [Page Memory & 10's Hold]	149
GLB-22 [Controller Calibration]	149

5. Write 151

6. Appendix 152

6.1 About data cards	152
6.2 About modulation sources	153
6.3 Modulation Source List	153
6.4 Performance Editor Assign Parameter List	154
6.5 LFO Wave List	160
6.6 MIDI Implementation	161
6.7 Troubleshooting	175
6.8 Error messages	175
6.9 Other messages	176

About this Parameter Guide

This Prophecy Parameter Guide is for use by those who have finished reading the accompanying Basic Guide, and by those who already have some knowledge of synthesizers. There is no need for you to read this guide from beginning to end ~ simply refer to it like a dictionary when you want to understand what appears in the Prophecy's display.

How to use this Parameter Guide

Example:
 Parameter page Parameter title
OSC-cmn6 [Portamento]

This parameter determines how the portamento effect (the smooth pitch change between notes) will be applied.

Summary

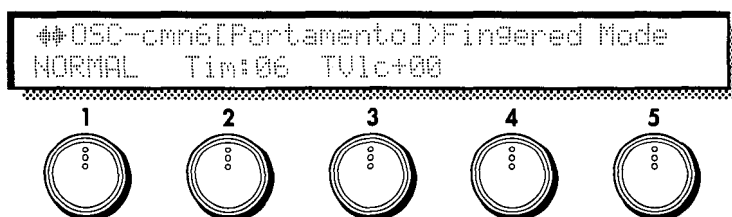

Setting range of parameter

This is the upper and lower limit of the parameter setting. The value can be adjusted using the VALUE keys, the knob or the numeric keys. If you use the numeric keys, enter the number and then press the ENTER key to finalize the value. Some parameters do not require the ENTER key to be pressed in order to finalize the value.

Abbreviated parameter name

Parameter name

3 Time Vel Ctrl

(Portamento Time Velocity Control)

[-99...+99]

This parameter specifies how velocity will affect the portamento time. With positive (+) settings, portamento time will be longer for strongly played notes, and with negative (-) settings the opposite will occur.

Knob number corresponding to this parameter

Explanation

Performance Editor

This indicates parameters that can be assigned by Performance Editor Define. The number corresponds to the number to input from the numeric keys. Use the numeric keys to input the number, and press the ENTER key.

•PE11

1. PERFORMANCE MODE

PERFORMANCE mode is the mode in which you will play the Prophecy. You can select programs and arpeggio patterns, and use the Performance Editor to modify the sound.

PERFORMANCE mode

Programs:

128 (bank A 00~63, bank B 00~63)

When an optional card is used, 64 additional programs are available (bank CARD 00~63)

Arpeggio patterns:

5 preset patterns (UP, DOWN, ALT1, ALT2, RANDOM), 5 user patterns (PAT1~5)

Performance Editor:

4 Performance Editor sets

In Performance mode, all MIDI data transmission takes place on the Global MIDI Channel setting of the Global section (see Global section page GLB-8). If Omni mode is OFF (see page GLB-8), reception takes place only on the Global MIDI Channel. If Omni is ON, all channel are received.

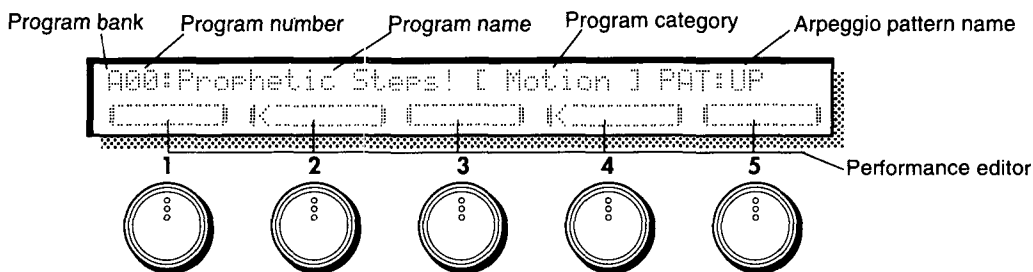

Program bank:

Use the front panel A, B, or CARD keys to select the corresponding bank.

Program number / Program name / Program category:

Use the Value keys, the numeric keys or a pedal switch to select programs. You can use the Page keys to select programs by program category.

Arpeggio pattern:

Use the INT PAT and CARD PAT keys to select the arpeggio pattern bank. When the PATTERN LED of the PATTERN/PROGRAM Select key is blinking, you can use the UP, DOWN, ALT1, ALT2, RANDOM, PAT1, PAT2, PAT3, PAT4, and PAT5 to select arpeggio patterns.

Performance editor:

The Performance Editor function allows you to use knobs 1~5 to edit the parameters which were assigned to each knob (in Performance Editor Define) without having to move to Edit mode. By turning on one or more of the PE1, PE2, PE3, and PE4 keys to activate one or more Performance Editor Sets, you can use the knobs to edit the Performance Editor parameters that were specified for each program.

Edits you perform using the Performance Editor knobs will affect the values of the program parameters in the edit buffer. If you wish to keep the changes you make, you must use the Write operation.

If the Global section page GLB-15 [SysEX Filter] Transmit is ON, MIDI Exclusive parameter change messages will be transmitted each time you operate the knobs 1~5.

If page GLB-15 [SysEX Filter] Receive is ENABLE, these messages can be received by another Prophecy, allowing remote Performance Editing.

Regardless of the settings of page GLB-15, MIDI controller messages specified in page GLB-5 will be transmitted and received for Performance Editing.

2.

PERFORMANCE EDITOR DEFINE MODE

In Performance mode, you can rotate knobs 1~5 to make realtime changes in the sound. This is called the Performance Editor function. For each Program, you can make four Performance Editor sets; PE1~4. For each PE set, you can assign five parameters, one to each knob 1~5.

PED-1 [PE1 Definition]

Select the parameter that is assigned to each knob 1-5 of PE1, and set the variable range and the curve of change.

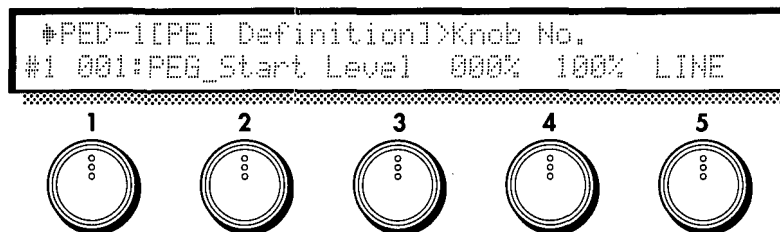

1 Knob No. [1...5]

Select the knob (1~5) to which you want to assign a parameter.

2 Assign Parameter [OFF...PluckInharmo]

Select one of 256 parameters to be controlled by the knob selected in Knob No. (Refer to 6.4 Performance Editor Assign Parameter List.)

3 Knob Left [0...100%]

This sets the lower limit of the change that will result when you turn the knob all the way to the left, expressed as a percentage of the variable range of the parameter. For example of the range of the parameter is -99~+99, setting Knob Left to 50% will mean that the parameter value would be 0 when the knob is rotated fully left. With a Knob Left setting of 0%, the parameter value would be -99.

4 Knob Right [0...100%]

This sets the upper limit of the change that will result when you turn the knob all the way to the right, expressed as a percentage of the variable range of the parameter. Refer to the explanation for Knob Left, above.

5 Curve [LINEAR, EXP, LOG]

Select one of three curves to determine how change will occur when you rotate the knob.

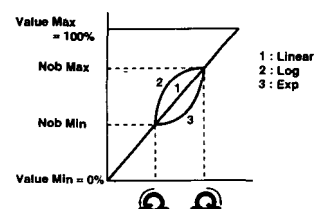

PED-2 [PE2 Definition]...PED-4 [PE4 Definition]

PED-2 specifies the parameter that is assigned to each knob 1–5 of PE2, and sets the variable range and the curve of change. In the same way, PED-3 makes settings for PE3, and PED-4 makes settings for PE4. The details of these settings are the same as for PED-1 [PE1 Definition]. Refer to the explanation for PED-1.

PED-5 [Initialize]

This initializes the PE parameter settings of the currently selected program.

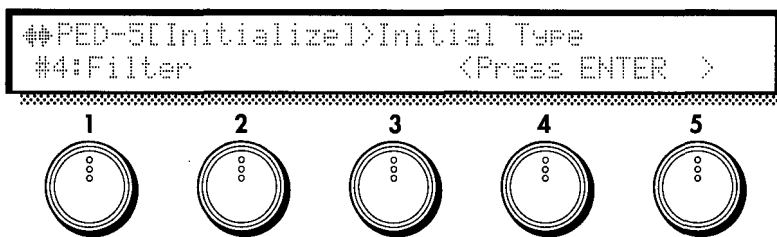

1 Initial Type

[#0...7]

Select one of the following recommended settings to assign parameters to the Performance Editor knobs.

- | | |
|----------------|--|
| #0:Default | All OFF, 000%, 100%, LINE |
| #1:OSC_Set | OSC section parameters will be assigned. (The optimal assignments for the current OSC_Set will be made automatically.) |
| #2:Mixer | Mixer section parameters will be assigned. |
| #3:Filter | Filter section parameters will be assigned. (The optimal assignments for the current Filter Routing will be made automatically.) |
| #4:Effect | Effect section parameters will be assigned. (The optimal assignments for the current Effect Type will be made automatically.) |
| #5:EG | EG section parameters will be assigned. |
| #6:Amp/PitchEG | AmpEG/PitchEG parameters will be assigned. |
| #7:LFO | LFO section parameters will be assigned. |

After you make a selection, press the ENTER key to execute.

PED-6 [Copy]

This copies PE parameter settings from another program.

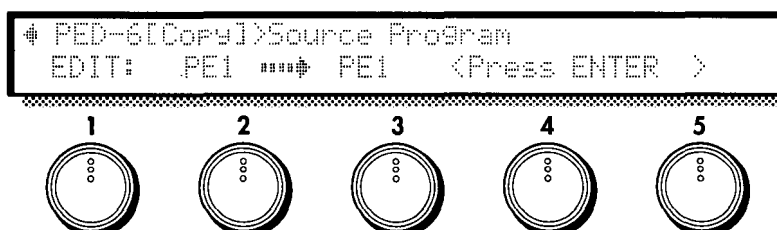

1 Source Program**[EDIT, A00...C63]**

Select the copy source program number. If you select EDIT, the program currently being edited (the program called into current memory) will be selected.

If you select C00~C63 and if a card is not inserted when you execute, the display will indicate <No Card>, and the operation will be halted.

If an un-formatted card is inserted, the display will indicate <Illegal Format>, and the operation will be halted.

2 Source PE**[PE1...4, ALL]**

Specify the copy source PE. If you select ALL, the following Destination selection will be ignored.

3 Destination (Target PE)**[PE1...4]**

Specify the (current) copy destination PE.

After you make your selection, press the ENTER key to execute.



If Source Program is set to EDIT, setting Source PE and Destination to the identical selection will result in a display of <Ignore>, and the operation will be halted.

3. ARPEGGIATOR PATTERN DEFINE MODE

There are five Preset arpeggiator patterns (UP, DOWN, ALT1, ALT2, RAND) and five User patterns (PAT 1~5). Here you can set the step base (eighth note, etc.) and select the basic arpeggiation method and controller (arpeggio parameters). For the five User patterns, you can also specify a Pattern parameter of up to 24 steps. Your settings will apply to the pattern which is currently selected in Performance mode. To change the selected Pattern, go back to Performance mode and select a different Pattern.

Settings for the preset patterns are made in pages 1~4, and settings for the user patterns are made in pages 1~6. Pages 1~3 contain the arpeggio pattern settings, and are the same for both preset and user patterns. In the actual displays, the Page Name will show the name of the pattern being edited, but in this manual the following sections will be titled as Arpeggio, and displays will be shown with an example pattern UP selected, Pattern as the page title of the pattern parameters, and PAT1 as the selected pattern.

! It is not possible to enter this mode if a CARD PAT pattern is selected. If you wish to edit a CARD PAT pattern, you must first copy the pattern to INT PAT.

Arpeggio-1 [Arpeggio Param]

These parameters determine the length of the notes, the order in which they will be sounded, and the range in which the arpeggio will be played.

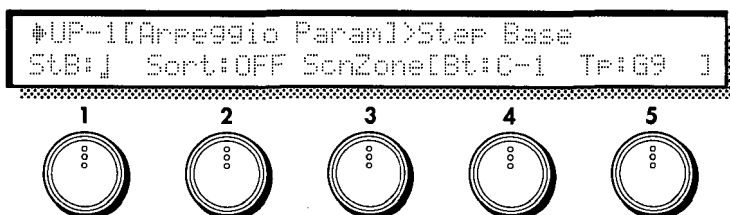

1 Step Base

[♩, ♪, ♪, ♪, ♪, ♪, ♪]

Set the note length of a step. If ♪ is selected, the length of the User Pattern will be a maximum of 3 measures (calculated with a MIDI clock as 1/96 of a measure).

2 Sort

(Note Sort)

[OFF, ON]

Specify the order in which arpeggio notes pressed on the keyboard will be sounded. With a setting of OFF, they will be sounded in the order that they were pressed. With a setting of ON, they will be sorted in order of pitch.

4 Kbd Scan Bottom (Keyboard Scan Zone Bottom)

[C-1...G9]

Specify the bottom key (lowest note) of the keyboard from which arpeggio notes can be specified.

5 Kbd Scan Top (Keyboard Scan Zone Top)

[C-1...G9]

Specify the top key (highest note) of the keyboard from which arpeggio notes can be specified.

! If you set the top key lower than the bottom key, no arpeggio will be played. Be sure to set the top key above the bottom key.

Arpeggio-2 [Velocity Param]

These are the velocity-related parameters for the arpeggio.

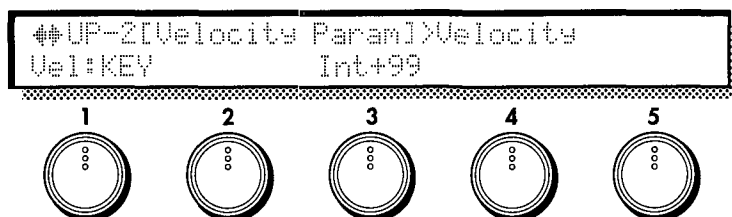

1 Velocity [1...127, KEY, STEP]

Specify the velocity (1~127) of the arpeggio notes. With a setting of 1~127, all arpeggio notes will have the same velocity. If KEY is selected, the velocity with which the note was played on the keyboard will be used. STEP can be selected only for a User Pattern, and the velocity of each arpeggio note will be as specified by the Step Velocity parameter (page Pattern-5,3).

3 Ctrl Intensity (Velocity Controller Intensity) [-99...+99]

Specify the amount of control that a selected controller will have on the velocity of the arpeggio notes. The controller is specified by the Global section page GLB-6 [Arpeggio Controller] Velocity setting (p.139).

Arpeggio-3 [Gate Param]

These parameters affect the Gate Time of the arpeggio notes.

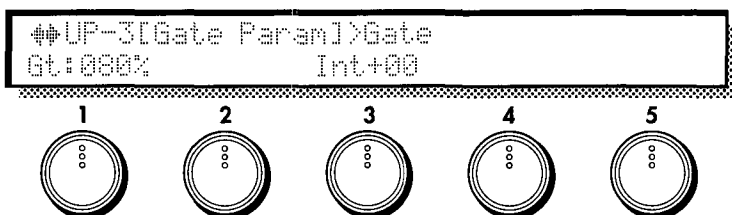

1 Gate [1...100%, STEP]

Specify the gate time (note length) for the arpeggio notes. Settings of 1~100% are values relative to the Step Base (page Arpeggio-1,1). As the value is increased, each note will be longer, and with a setting of 100%, the arpeggio notes will be legato. A setting of STEP can be selected only for a User Pattern, and the gate time of each arpeggio note will be as specified by the Gate Ratio parameter (page Pattern-5,4).

4 Ctrl Intensity (Gate Controller Intensity) [-99...+99]

Specify the amount of control that a selected controller will have on the Gate Time of the arpeggio notes. The controller is specified by the Global section page GLB-6 [Arpeggio Controller] Gate (p.139).

Arpeggio-4 [Pattern Copy]

* This is displayed when a Preset Pattern is selected.

This copies the identically-numbered Preset Pattern from a data card into the currently selected Preset Pattern. Press the ENTER key to execute.

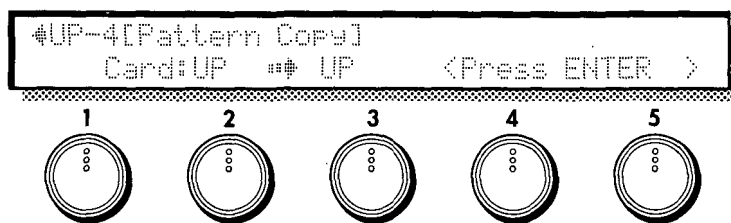

Pattern-4 [User Pat Param]

These settings determine the order in which notes of a User Pattern are sounded.

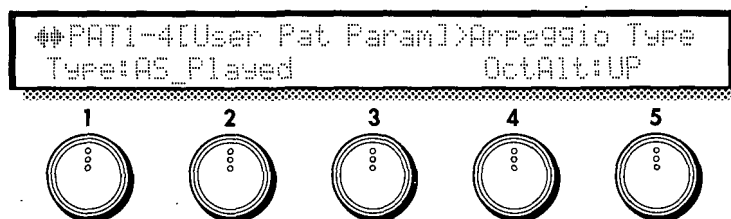

2 Arpeggio Type

[As_Played...UP&DOWN]

This determines the relation between the arpeggio notes played on the keyboard and the Tone (page Pattern-5,3) of each step.

As_Played :

If the Tone of a step exceeds the number of specified arpeggio notes (played on the keyboard), that step will not sound.

As_Played(FILL) :

If the Tone of a step exceeds the number of specified arpeggio notes (played on the keyboard), the last arpeggio note (the last-played note if Sort:OFF, or the lowest note if Sort:ON) will be sounded.

Running_UP :

If the Tone of a step exceeds the number of specified arpeggio notes (played on the keyboard), arpeggiation will return to the first arpeggio note (the first-played note if Sort:OFF, or the lowest note if Sort:OFF).

UP&DOWN :

If the Tone of a step exceeds the number of specified arpeggio notes (played on the keyboard), arpeggiation will return backward from the last arpeggio note.

Example) If for Step Number (page Pattern-5,1) #05 Tone has been set to LOOP (so that Tone 1~4 will be arpeggiated repeatedly):

If 3 notes are pressed with As_Played:	1 → 2 → 3 → rest → 1 → 2 → 3 → rest → 1 ...
If 3 notes are pressed with As_Played(FILL):	1 → 2 → 3 → 3 → 1 → 2 → 3 → 3 → 1 ...
If 3 notes are pressed with Running_UP:	1 → 2 → 3 → 1 → 1 → 2 → 3 → 1 → 1 ...
If 3 notes are pressed with UP&DOWN:	1 → 2 → 3 → 2 → 1 → 2 → 3 → 2 → 1 ...

5 Oct Alternation (Octave Alternation)

[UP, DOWN, UP&DOWN]

This specifies how arpeggiation will operate when the OCTAVE switch is set to 2~4 octaves.

UP: Repeated ascent within the specified number of octaves.

DOWN: Repeated descent within the specified number of octaves.

UP&DOWN: Repeated ascent and descent within the specified number of octaves.

Pattern-5 [Step]

Specify each step of the User Pattern.

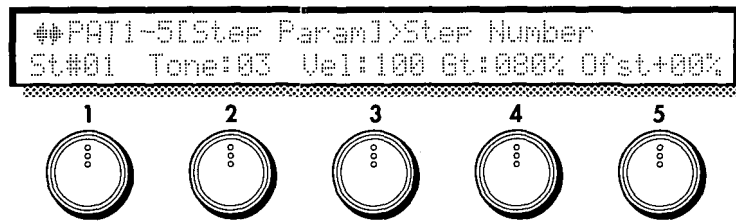

1 Step Number

[#1...24]

Specify the step number that you wish to set.

2 Tone

[1...12, LOOP]

Specify the arpeggio note that will be sounded.

If Sort (page Arpeggio-1,2) is OFF, notes will sound in the order in which they were played on the keyboard. If Sort:ON, they will be sounded from the lowest note, in the order of the Tone number you specify here. If LOOP is selected, the arpeggio will return to the first step at the timing of that step. (It is not possible to set LOOP to step number #1.)

3 Step Velocity

[1...127]

Specify the velocity for each step.

4 Gate Ratio

[OFF, 1...100%]

Specify the length of the note, relative to the Step Base setting (page Arpeggio-1,1) as 100%. A setting of OFF is a rest, and 100% is legato.

5 Timing Offset

[-49...+49%]

Adjust the Note-on timing of each step forward or backward, in a range of -49~+49% relative to the Step Base (page Arpeggio-1,2) as 100%.

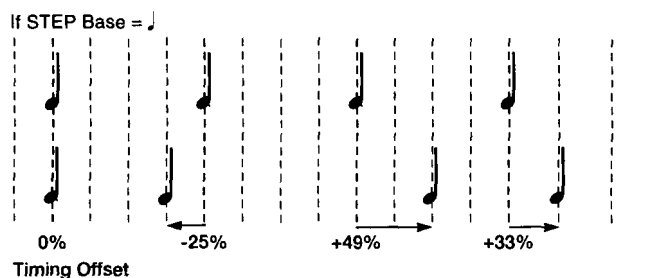

Pattern-6 [Pattern Copy]

Here you can copy another User Pattern to the currently selected pattern.

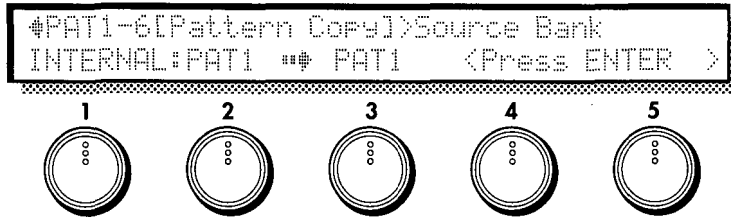

1 Source Bank

[INTERNAL, CARD]

Select the copy source pattern bank.

2 Source Pattern

[PAT1...PAT5]

Select the copy source pattern.

Make the desired selection, and press the ENTER key to execute.

4. EDIT MODE

- 4-1. OSC Section
- 4-2. WAVE SHAPE Section
- 4-3. MIXER Section
- 4-4. FILTER Section
- 4-5. AMPLIFIER Section
- 4-6. EFFECT Section
- 4-7. EG Section
- 4-8. LFO Section
- 4-9. COMMON Section
- 4-10. GLOBAL Section

4-1. OSC Section

OSC-cmn1 [Oscillator Set]

Select one of 12 combinations (oscillator sets) to determine which of seven oscillator types (Standard Oscillator, Comb Filter Oscillator, VPM Oscillator, (Cross/Sync/Ring) Modulation Oscillator, Brass Model Oscillator, Reed Model Oscillator, and Plucked String Oscillator) will be used for each oscillator 1 and 2.

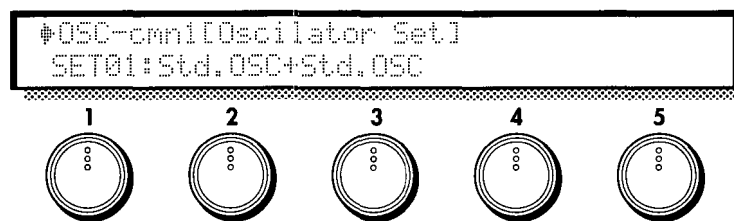

1 Oscillator Set

[SET1...SET12]

Select a set 1~12 to determine the oscillator type for oscillator 1 and 2. Sets 1~9 use two oscillators (1 and 2). Sets 10~12 use only oscillator 1. (However since the pitch-related parameters for oscillator 2 will be still valid, they can be used to control the pitch of the sub oscillator.)

Set	Oscillator 1	Oscillator 2
Set 1	Standard OSC	Standard OSC
Set 2	Standard OSC	Comb Filter OSC
Set 3	Standard OSC	VPM OSC
Set 4	Standard OSC	Modulation OSC
Set 5	Comb Filter OSC	Comb Filter OSC
Set 6	Comb Filter OSC	VPM OSC
Set 7	Comb Filter OSC	Modulation OSC
Set 8	VPM OSC	VPM OSC
Set 9	VPM OSC	Modulation OSC
Set 10	Brass OSC	no oscillator (OSC2)
Set 11	Reed OSC	no oscillator (OSC2)
Set 12	Pluck OSC	no oscillator (OSC2)

Make the desired selection, and press the ENTER key to execute.

For details on each oscillator type, refer to the following pages.

Standard Oscillator - p.23, Comb Filter Oscillator - p.26, VPM Oscillator - p.30, (Cross/Sync/Ring) Modulation Oscillator - p.36, Brass Model Oscillator - p.40, Reed Model Oscillator - p.46, Plucked String Oscillator - P.40

OSC-cmn2 [Pitch EG Level] Pitch EG

OSC-cmn2~4 contain Pitch EG settings. The Pitch EG controls the way in which the oscillator pitch changes over time.

The Pitch EG of the Prophecy can also be used as a general-purpose controller, meaning that it can provide time-varying control over a variety of other parameters in addition to the pitch.

The settings here will determine the amounts of pitch change that occur in response to pressing and releasing a key.

In order to use the Pitch EG to control the pitch, you need to make Pitch EG settings in Pitch Modulation EG (page OSC 1-2,2 / OSC2-2,2) and set the depth of the effect in Pitch Mod. Intensity (page OSC 1-2,3 / OSC 2-2,3).

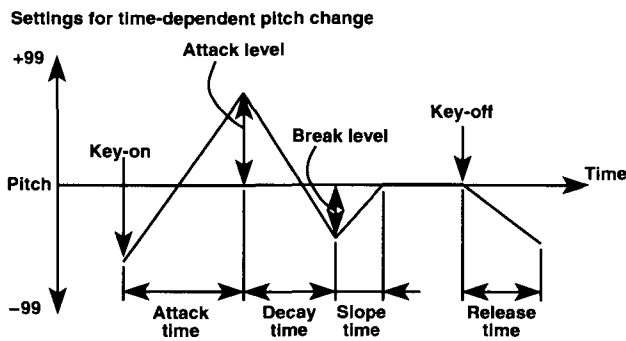

```

+OSC-cmn2[PitchEG Level]>Start Level
StaL+00 AtkL+99 BrkL-30 RlsL-30
    
```

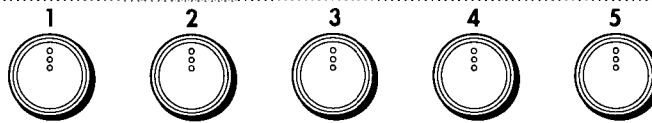

1 Start Level [-99...+99]

Specify the pitch level when the note is pressed (key-on). Positive (+) settings will cause the pitch to be higher than the standard pitch, and negative (-) settings will cause the pitch to be lower than the standard pitch.

•PE1

2 Attack Level [-99...+99]

Specify the pitch level that will be reached after the Attack Time. (Refer to the explanation for Start Level.)

•PE3

3 Break Level [-99...+99]

Specify the pitch level that will be reached after the Decay Time has elapsed. (Refer to the explanation for Start Level.)

•PE5

5 Release Level [-99...+99]

Specify the pitch level that will be reached when the Release Time has elapsed after key-off. (Refer to the explanation for Start Level.)

•PE8

* After the Slope Time has elapsed until you release the note (Key-off), the pitch will be at the standard pitch.

4. EDIT MODE

OSC-cmn3 [Pitch EG Time] Pitch EG

Specify the time over which the oscillator pitch will change in response to a note being pressed and released.

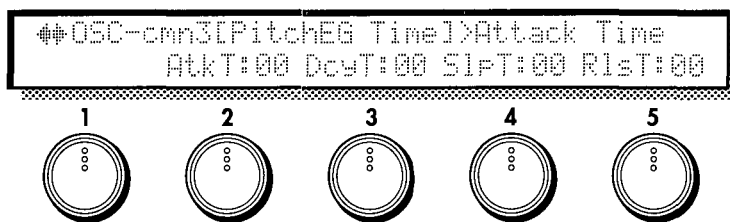

2 Attack Time [0...99]

Specify the time over which the pitch will change from key-on (pressing a key) until the pitch of the Attack Level is reached. With a setting of 0, the pitch will change instantly. With a setting of 99, the pitch will change slowly.

•PE2

3 Decay Time [0...99]

Specify the time over which the pitch will change from the Attack Level to the Break Point. (Refer to the explanation for Attack Time.)

•PE4

4 Slope Time [0...99]

Specify the time over which the pitch will return from the Break Level to the standard pitch. (Refer to the explanation for Attack Time.)

•PE6

5 Release Time [0...99]

Specify the time over which the pitch will change after key-off (releasing a key) until the Release Level is reached. (Refer to the explanation for Attack Time.)

•PE7

OSC-cmn4 [Pitch EG Ctrl]

Pitch EG Keyboard Tracking/Velocity Control

These settings determine how keyboard tracking (note position on the keyboard) and velocity (the force with which you strike a note) will affect the Pitch EG.

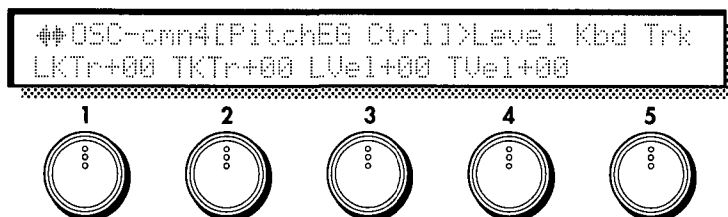

1 Level Kbd Trk (Level Keyboard Tracking) [-99...+99]

Specify how keyboard tracking will affect the Pitch EG Levels. Positive (+) settings will result in increased Pitch EG Levels as you play above the C4 key, causing greater pitch change. Negative (-) settings will result in decreased Pitch EG Levels as you play above the C4 key, causing less pitch change.

2 Time Kbd Trk (Time Keyboard Tracking) [-99...+99]

Specify how keyboard tracking will affect the Pitch EG Times. Positive (+) settings will result in longer Pitch EG Times as you play above the C4 key. Negative (-) settings will result in shorter Pitch EG Times as you play above the C4 key.

3 Level Veloc Ctl (Level Velocity Control) [-99...+99]

Specify how velocity will affect the Pitch EG Levels. With positive (+) settings, Pitch EG Levels will be increased as you play with more velocity (i.e., the amount of pitch change will increase). With negative (-) settings, there will be less pitch change as you play with more velocity.

4 Time Veloc Ctl (Time Velocity Control) [-99...+99]

Specify how velocity will affect the Pitch EG Times. With positive (+) settings, pitch change will occur more quickly as you play with more velocity (i.e., Pitch EG Times will be shortened). With negative (-) settings, pitch change will occur more slowly as you play with more velocity.

Level changes (with positive (+) settings)

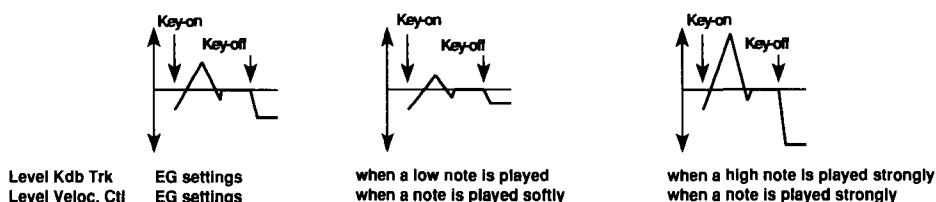

Time changes (with positive (+) settings)

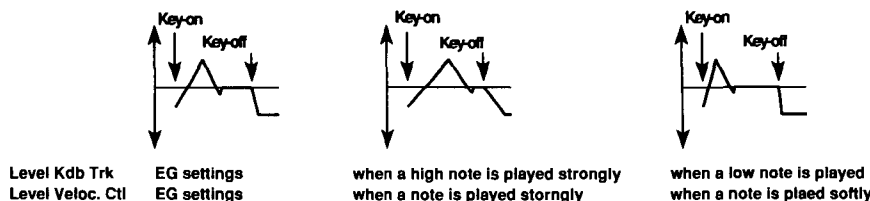

OSC-cmn5 [Pitch Bend]

Pitch Bender/After Touch Bending

These parameters let you specify the direction and amount of the pitch change controlled by the Pitch Bender and Aftertouch (pressing the keyboard after playing a note).

To control these using WHEEL 1,2,3, the Ribbon controller, or the Foot Pedal, make settings in Common section, CMN-5~8.

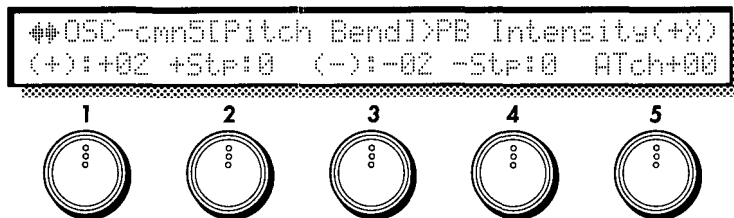

1 PB Intensity(+X) (Pitch Bender Intensity (+X)) **[-60...+12]**

Specify the amount (in chromatic steps) and the direction of the pitch change that will occur when the Pitch Bender is moved in the positive (+) direction. With positive (+) settings the pitch will rise, and with negative (-) the pitch will fall. A setting of 12 allows 1 octave of change.

2 PB Step(+X) (Pitch Bender Step (+X)) **[0, /8, /4, /2, 1...12]**

Specify the type of pitch change that will occur when the Pitch Bender is moved in the positive (+) direction. For each setting of this parameter, the pitch will change as follows.

- 0 Continuous → smooth change
- /8 1/8 → change in units of 1/8 chromatic step
- /4 1/4 → change in units of 1/4 chromatic step
- /2 1/2 → change in units of 1/2 chromatic step
- 1...12 1~12 → change in units of the specified number of chromatic steps (maximum of 1 octave)

! If the Pitch Bender Step (+X) pitch is greater than the pitch specified for Pitch Bender Intensity (+X), the pitch will not change.

3 PB Intensity(-X) (Pitch Bender Intensity (-X)) **[-60...+12]**

Specify the amount (in chromatic steps) and the direction of the pitch change that will occur when the Pitch Bender is moved in the negative (-) direction. With positive (+) settings the pitch will rise, and with negative (-) the pitch will fall. A setting of 12 allows 1 octave of change.

4 PB Step(-X) (Pitch Bender Step (-X)) **[0, /8, /4, /2, 1...12]**

Specify the type of pitch change that will occur when the Pitch Bender is moved in the negative (-) direction. For each setting of this parameter, the pitch will change as explained in Pitch Bender Step (+X), above.

! If the Pitch Bender Step (-X) pitch is greater than the pitch specified for Pitch Bender Intensity (-X), the pitch will not change.

5 AfterTouchBending (After Touch Bending) **[-12...+12]**

Specify the amount (in chromatic steps) and the direction of pitch bend that will occur in response to Aftertouch. With positive (+) settings Aftertouch will raise the pitch, and with negative (-) settings will lower the pitch.

OSC-cmn6 [Portamento]

These parameters determine the operation of the portamento effect (the smooth movement from one pitch to the next).

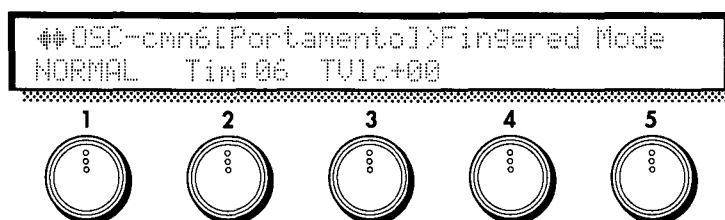

1 Fingered Mode [NORMAL, FINGERED]

NORMAL : Portamento will always be applied, regardless of the playing technique.

FINGERED: Portamento will be applied only if the next key is pressed before releasing the previous key (i.e., legato).

•PE9

2 Portamento Time [0...99]

Specify the portamento time. Higher settings will cause slower pitch change (30 seconds at the maximum value).

•PE10

3 Time Vel Ctrl [-99...+99] (Portamento Time Velocity Control)

Specify how velocity will affect the portamento time. With positive (+) settings, strongly played notes (high velocities) will lengthen the portamento time. With negative (-) settings, strongly played notes will shorten the portamento time.

•PE11

OSC-cmn7 OSC Menu

This is the oscillator menu page.

The displayed menu items will depend on the setting of OSC-cmn1 [Oscillator Set].

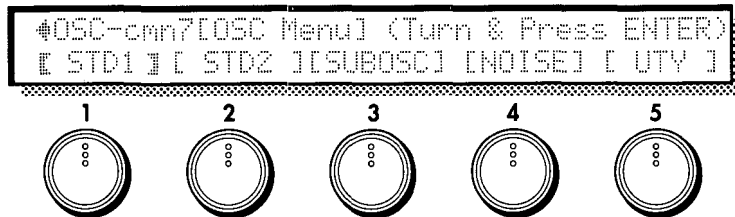

1 [STD1], [COMB1], [VPM1], [Brass], [Reed], [Pluck] (Oscillator 1)

2 [STD2], [COMB2], [VPM2], [MOD2], [OSC2] (Oscillator 2)

3 [SUBOSC] (Sub Oscillator)

4 [NOISE] (Noise Generator)

5 [UTY] (Utility)

Here you can select the item you wish to edit; Oscillator 1, Oscillator 2, Sub Oscillator, Noise Generator, or Utility.

For Oscillator 1 and 2, the oscillator type selected by Oscillator Set (page OSC-cmn1,1) will be displayed, and you can make settings for that oscillator type. [STD1] and [STD2] edit the Standard OSC (p.23), [COMB1] and [COMB2] edit the Comb Filter OSC (p.26), [VPM1] and [VPM2] edit the VPM OSC (p.30), [MOD2] edits the (Cross/Sync/Ring) Modulation OSC (p.36), [Brass] edits the Brass OSC (p.40), [Reed] edits the Reed OSC (p.46), and [Pluck] edits the Pluck OSC (p.50). If Oscillator Set is set to SET 10~12 (Brass OSC, Reed OSC, Pluck OSC), Oscillator 2 will be displayed as [OSC2]. This is not an oscillator, but contains settings that specify the sub oscillator's basic pitch and pitch modulation. [SUBOSC] edits sub oscillator settings, and [NOISE] edits noise generator settings. [UTY] allows you to initialize and copy oscillator-related settings.

Use the CURSOR keys or the knobs to select the item you wish to edit, and press the ENTER key to enter each item.

Oscillator 1, Oscillator 2

Here you can make settings for each oscillator type. Oscillator 1 pages OSC1-1~4 and oscillator 2 pages OSC2-1~4 contain settings that determine the basic pitch of the oscillator, and are organized in the same way for all oscillator types. From pages OSC1-5 and OSC2-5, the parameter structure will be different for each oscillator type. However oscillator 2's [OSC2] contains settings for the pitch of the sub oscillator, consists of pages OSC2-1~4.

OSC1-1 [Basic Pitch]

These parameters specify the basic pitch of oscillator 1.

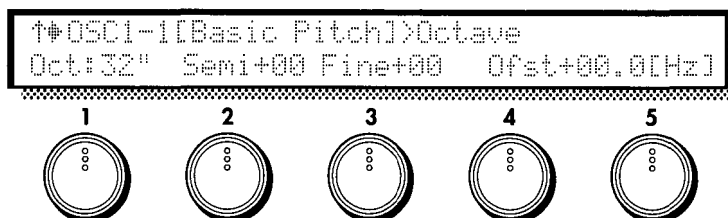

1 Octave [32" ..4"]

Set the basic pitch of oscillator 1 in octave units. A setting of 32" is 2 octaves down, 16" is 1 octave down, 8" is the standard pitch, and 4" is 1 octave up.

•PE12 : OSC1 •PE18 : OSC2

2 Semi Tone [-12...+12]

This is an adjustment in semitone units to the basic pitch specified by the Octave setting.

•PE13 : OSC1 •PE19 : OSC2

3 Fine Tune [-50...+50cent]

This is a fine adjustment to the basic pitch in steps of 1 cent.

•PE14 : OSC1 •PE20 : OSC2

5 Frequency Offset [-10.0...+10.0Hz]

This is a fine adjustment to the basic pitch in steps of 0.1 Hz.

•PE15 : OSC1 •PE21 : OSC2



For oscillator types which use a physical model, "Frequency Offset" settings can result in unstable oscillation.

OSC1-2 [Pitch Modulation]

These parameters specify how modulation will control the basic pitch of oscillator 1.

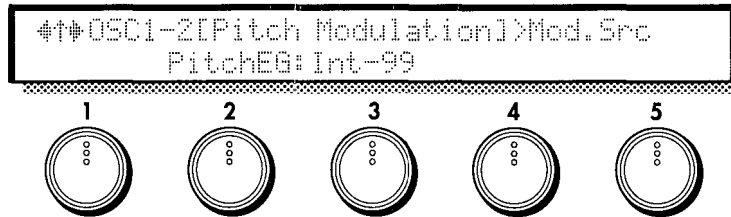

2 Mod.Src (Pitch Modulation Source) **[OFF...CChg#95]**

Select the modulation source that will control the pitch. (Refer to 6.3 Modulation Source List.)

3 Mod.Int (Pitch Mod.Intensity) **[-99...+99]**

Specify the depth and direction of the pitch change that can be controlled by the Pitch Modulation Source.

•PE17 : OSC1 •PE23 : OSC2

OSC1-3 [Pitch Slope]

These parameters specify how keyboard tracking (keyboard location) will affect the basic pitch of oscillator 1.

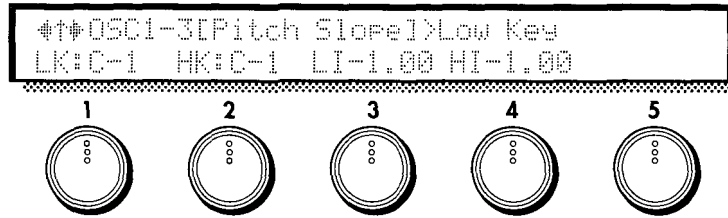

1 Low Key

[C-1...G9]

Specify the key at which Lower keyboard tracking will begin.

2 High Key

[C-1...G9]

Specify the key at which Higher keyboard tracking will begin.

3 Lower Intensity

[-1.0...+2.0]

Specify the depth and direction of the pitch change that will occur for the area of the keyboard below the Low Key.

4 Higher Intensity

[-1.0...+2.0]

Specify the depth and direction of the pitch change that will occur for the area of the keyboard above the High Key.

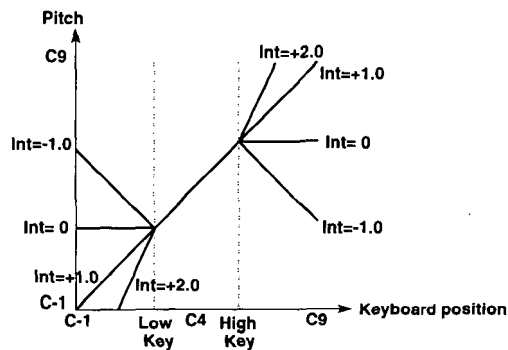

If Higher Intensity or Lower Intensity is set to a value of +2.0, playing one octave higher (within the area specified by High Key and Low Key) will produce in a pitch two octaves higher. With a setting of -1.0, playing one octave higher (within the specified area) will produce a pitch one octave lower. With a setting of 0.0, the pitch will remain fixed within the specified area. If you wish to play normal pitches, set Intensity to +1.0. The area between Low Key and High Key will always produce normal pitches.

OSC1-4 [Pitch Mod LFO] - Pitch Modulation LFO

These parameters make settings for the LFO that will affect the basic pitch of oscillator 1.

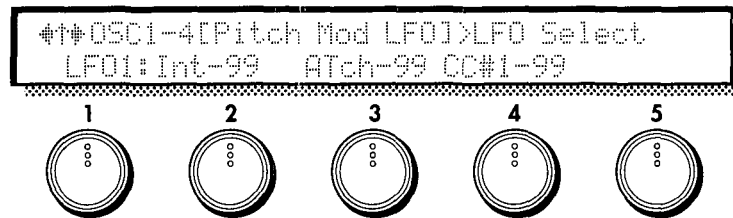

1 LFO Select [LFO1...4]

Select the LFO that will cyclically modulate the pitch, creating a vibrato effect. For the settings of each LFO, refer to the LFO section (p.118).

2 Intensity (Pitch Mod. LFO Intensity) [-99...+99]

Specify the depth of the pitch change that will be caused by the LFO selected in LFO Select. With positive (+) settings, vibrato will be applied using the original phase of the LFO waveform. With negative (-) settings, vibrato will be applied using the LFO waveform in inverted phase.

•PE16 : OSC1 •PE22 : OSC2

3 Int.AT Control (Intensity AT Control) [-99...+99]

Specify how greatly Aftertouch will control the depth of the LFO pitch modulation effect.

4 Int.CC#1 Ctrl (Intensity CC#1 Control) [-99...+99]

Specify how greatly Control Change #1 will control the depth of the LFO pitch modulation effect.

* OSC1-5 and following are explained in the following pages for each oscillator type.

OSC2-1 [Basic Pitch] ...OSC2-4 [Pitch Mod LFO]

These parameters specify the basic pitch, pitch keyboard tracking, pitch modulation etc. for oscillator 2.

The oscillator 2 parameters are organized identically to the oscillator 1 parameters. Refer to pages OSC1-1 [Basic Pitch] ... OSC1-4 [Pitch Mod LFO].

Standard Oscillator

This oscillator produces the sawtooth, pulse, and ramp waveforms used by analog synthesizers.

Either sawtooth or pulse wave will be selected as the main waveform, and ramp wave will be mixed with this for output. The levels of both can be adjusted independently.

* These parameters are displayed when you select Set 1~4 for the page OSC-cmn1 [Oscillator Set] parameter.

Waveform Modulation

Analog synthesizers of the past etc. had a function called Pulse Width Modulation (PWM), which changed the pulse width of a pulse wave over time. However, Waveform Modulation is an extension of this which can modulate the waveform of not only pulse waves, but also sawtooth waves or ramp waves.

Sawtooth wave

Waveform Modulation can be applied to modify the waveform as shown below, creating changes in tone color over time. When modulation is at 0, the basic sawtooth wave is produced. When modulation is at 99, a sawtooth wave of double the frequency is produced. If the modulation value is negative, the waveform will be affected in the way opposite from positive values.

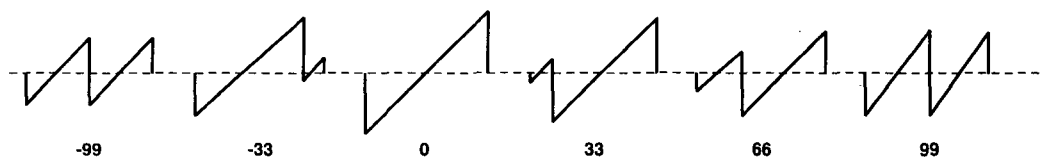

Pulse wave

Waveform (Pulsewidth) Modulation can be applied to modify the waveform as shown below, creating changes in tone color over time. When modulation is at 0, a square wave is produced. When modulation is at 99, the pulse width will be 0 and there will be no sound. If the modulation value is negative, the waveform will be affected in the way opposite from positive values.



Ramp wave

Waveform Modulation can be applied to modify the waveform as shown below, creating changes in tone color over time. When modulation is at 0, a triangle wave is produced. As the modulation value increases, the waveform becomes a ramp wave (a waveform with a two-stage broken slope). With a value of 50 a trapezoid waveform will result, and a value of 99 will once again produce a triangle wave. If the modulation value is negative, the waveform will be affected in the way opposite from positive values.

Compared to sawtooth and square waves, ramp waves have fewer overtones and a stronger fundamental, making them especially suitable for bass sounds, etc.

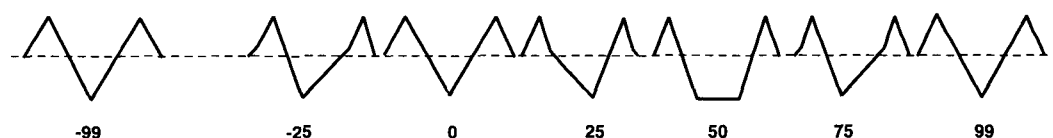

OSC1-5 [STD WaveLevel] - OSC Setting

These parameters let you select the main output waveform of the oscillator (SAW or PULSE), and mix in the output of the ramp wave.

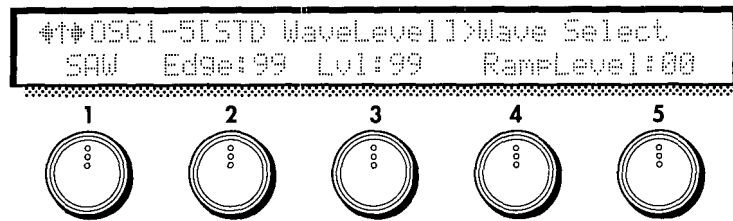

1 Wave Select [SAW, PULSE]

Select the main waveform; either SAW (sawtooth wave) or PULSE (pulse wave).

•PE189 : STD1 •PE195 : STD2

2 Wave Edge [0...99]

Adjust the amount of high overtones for the main waveform. This will intensify for higher notes, and will have little effect on lower notes. With lower settings of this parameter, the sound will be more mellow. For settings in the area of 0, the volume will also be decreased.

3 Wave Level [0...99]

Set the output level of the main waveform.

•PE190 : STD1 •PE196 : STD2

5 Ramp Wave Level [0...99]

Set the output level of the ramp waveform. This will be mixed with the main waveform for output.

•PE191 : STD1 •PE197 : STD2

OSC1-6 [STD Wave Form] - Wave Form Modulation

These parameters set the waveform, and specify how the waveform will be affected by an LFO and by another source such as EG or Aftertouch.

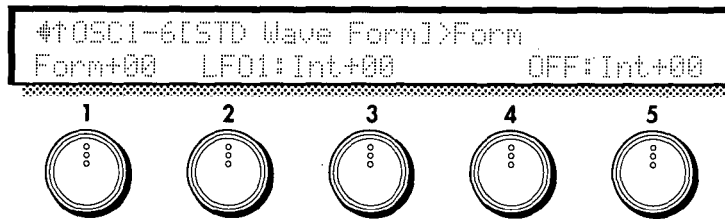

1 Form (Wave Form) **[-99...+99]**

Set the waveform. p.23 explains how this value affects the waveform.

•PE192: STD1 •PE198: STD2

2 Form Mod.LFO (Wave Form Modulation LFO) **[LFO1...LFO4]**

Select the source LFO for waveform modulation. LFO settings are made in the LFO section (p.118).

3 Form Mod.LFO Int (Wave Form Mod. LFO Intensity) **[-99...+99]**

Set the depth and direction of the waveform modulation that will be applied by the LFO that you selected in (Wave) Form Mod.LFO. Negative values will invert the direction of the effect.

•PE193: STD1 •PE199: STD2

4 Form Mod.Source (Wave Form Modulation Source) **[OFF...CChg#95]**

Select the waveform modulation source (refer to 6.3 Modulation Source List).

5 Form Mod.Int (Wave Form Mod. Intensity) **[-99...+99]**

Set the depth and direction of the waveform modulation that will be applied from the modulation source you selected for Wave Form Modulation Source.

Negative values will invert the phase of the modulation source.

•PE194: STD1 •PE200: STD2

COMB Filter Oscillator

The Comb Filter Oscillator inputs noise and an oscillator waveform into a comb filter, and produces characteristic changes in sound when the feedback level of the filter is modified. When noise is input, increasing the feedback level of the comb filter will cause the sound to have a progressively clearer sense of pitch.

* These parameters will be displayed when you have selected Set 2 or 5~7 for page OSC-cmn1 [Oscillator Set].

FIG.1 Comb Oscillator Block

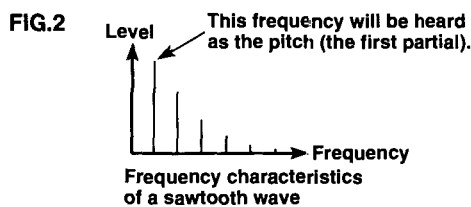
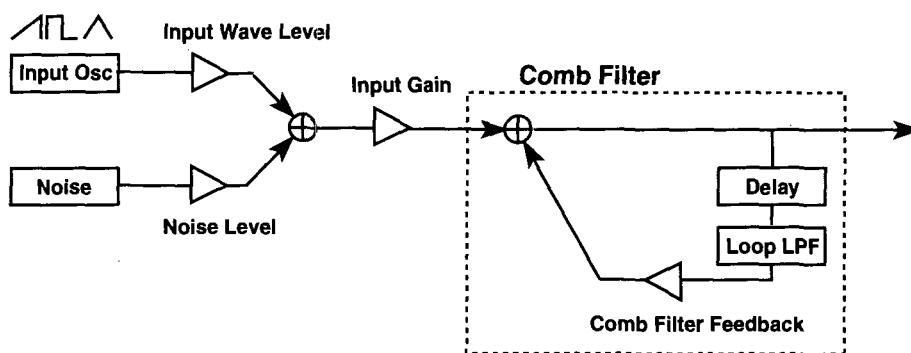

OSC1-5 [COMB Input]

These parameters set the levels of the noise and oscillator that are input into the comb filter.

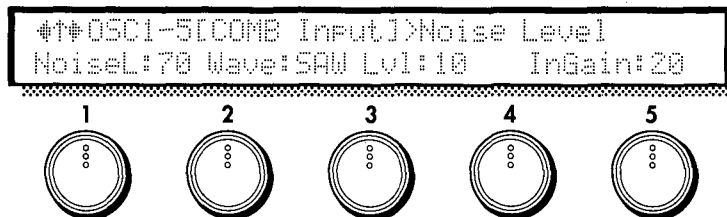

1 Noise Level [0...99]

Specify the noise volume level that will be input into the comb filter.

•PE201 : COMB1 •PE207 : COMB2

2 Input Wave Form [SAW, SQU, TRI]

Select the oscillator waveform that will be input into the comb filter.

3 Input Wave Level [0...99]

Specify the oscillator volume level that will be input into the comb filter.

•PE202 : COMB1 •PE208 : COMB2

5 Input Gain [0...99]

Specify the input level to the comb filter.



When Comb Filter Feedback (page OSC1-6,1 / OSC2-6,1) is increased from 0 toward 99, the sound may become distorted as 99 is approached. If this occurs, set this parameter to limit the level beforehand to minimize the differences in output level from the comb filter.

OSC1-6 [COMB Feedback]

These parameters specify the Comb Filter Feedback level and the specify how EG and modulation will control it.

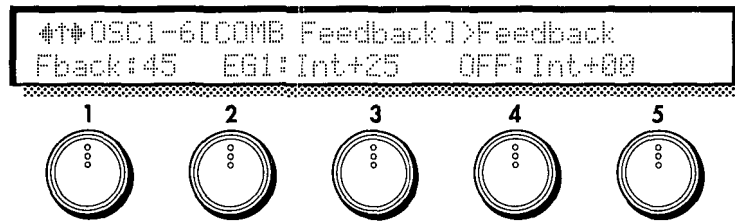

1 Feedback (Comb Filter Feedback) [0...99]

Set the feedback level of the comb filter. As this value is increased, the resonance of the comb filter will become higher, resulting in a more pitched sound. Conversely, with lower settings of this value, the input signal will be output without modification, and if the input signal is noise, the output signal will have no sense of pitch.

•PE203 : COMB1 •PE209 : COMB2

2 Feedback Mod. EG (Feedback Modulation EG) [EG1...4/P.EG/A.EG]

Select the EG (envelope generator) that will create time-based change in Comb Filter Feedback. For details on EG settings, refer to p.111 for EG1~4, p.13 for the P.EG, and p.84 for the A.EG.

3 Mod. EG Int (Feedback Mod. EG Intensity) [-99...+99]

Specify the depth of the change produced by the EG that is selected in Feedback Modulation EG. With positive (+) settings, the standard polarity of the EG will be used. With negative (-) settings, the EG polarity will be inverted.

•PE204 : COMB1 •PE210 : COMB2

4 Fbk Mod.Source (Feedback Modulation Source) [OFF...CChg#95]

Select the modulation source that will control Comb Filter Feedback. (Refer to 6.3 Modulation Source List.)

5 Fbk Mod.Int (Feedback Modulation Intensity) [-99...+99]

Specify the depth and direction of the effect produced by the modulation source selected in Feedback Modulation Source. Positive (+) settings will allow the Comb Filter Feedback value to be increased, and negative (-) settings will allow it to be decreased. If the Feedback Modulation Source parameter is set to EG or LFO, positive (+) settings will cause the standard polarity of the EG or LFO to be used, and negative (-) settings will invert the polarity.

•PE205 : COMB1 •PE211 : COMB2

OSC1-7 [COMB Loop LPF Frequency]

This parameter sets the cutoff frequency of the low pass filter located inside the comb filter.

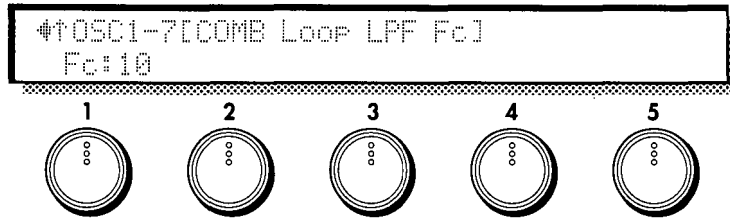

1 Comb Loop LPF Frequency

[0...99]

Specify the cutoff frequency of the low pass filter located inside the comb filter. When this value is low, the high frequencies will be cut from the signal passing through the comb filter, resulting in a more mellow sound. Higher settings of this value will result in a more brilliant sound.

•PE206 : COMB1 •PE212 : COMB2

- ⚠ Depending on the settings of [COMB Feedback] (page OSC1-6 / OSC2-6) and this low pass cutoff frequency setting, the output of the oscillator may be distorted. Also, if the feedback level specified by [COMB Feedback] is high when you change the value of this setting, a certain amount of time may be required for the filter to reach the value that you set. These situations are due to the characteristics of the comb filter, and in such cases, you should lower either the [COMB Feedback] setting or the setting of this parameter.

VPM Oscillator

In this oscillator, the output of a carrier is phase-modulated by a modulator, passed through a wave shaping circuit to emphasize the high frequencies, and then output.

By controlling the wave shaping parameters, you can create tonal changes that are different than those produced simply by phase modulation alone.

* These parameters will be displayed when Set 3, 6, 8, or 9 is selected in page OSC-cmn1 [Oscillator Set].

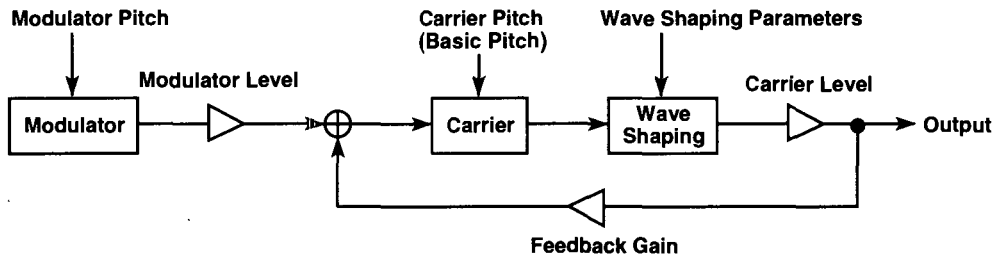

Carrier

This is the waveform that determines the basic pitch and volume. For the carrier you can select sine (SIN), sawtooth (SAW), triangle (TRI) or square (SQU) waveforms, and this waveform will be phase-modulated by the modulator.

Modulator

This is the waveform that modulates the carrier. VPM allows you to select from sine, sawtooth, triangle, or square wave oscillators to phase-modulate the carrier. Most commonly, an EG etc. is used to control the pitch of the modulator to create interesting changes in tone.

Wave Shaping

This section passes the value of the input waveform through a mathematical function and outputs the result. The VPM oscillator uses a sine wave function that emphasizes specific high frequencies. By adjusting the wave shaping parameters to control the frequency of this sine wave, you can modify the point at which the high frequencies will be emphasized.

OSC1-5 [VPM Carrier Wave]

This parameter selects the carrier waveform.

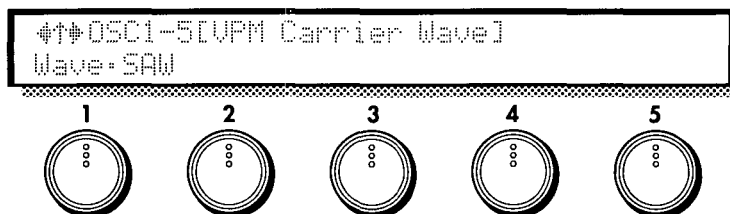

1 VPM Carrier Wave

[SIN, SAW, TRI, SQU]

Select the carrier waveform.

•PE213 : VPM1 •PE226 : VPM2

OSC1-6 VPM Carrier

These parameters set the output level of the carrier, and determine the EG and modulation settings.

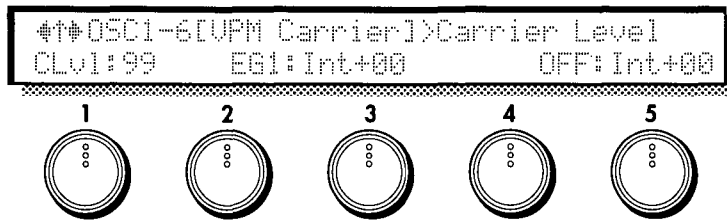

1 Carrier Level [0...99]

Set the output level of the carrier. This determines the output level of the VPM oscillator.

•PE214 : VPM1 •PE227 : VPM2

2 Level Mod.EG (Carrier Level Modulation EG) [EG1...4, P.EG, A.EG]

Select the EG that will control the output level of the carrier. For the EG settings, refer to p.111 for EG1~4, p.13 for P.EG, and p.84 for A.EG.

3 Mod.EG Intensity (Carrier Level Modulation EG Intensity) [-99...+99]

Specify the depth and direction in which the EG selected for Carrier Level Modulation EG will control the carrier level. Negative values will invert the polarity of the EG.

•PE215 : VPM1 •PE228 : VPM2

4 Level Mod.Source (Carrier Level Modulation Source) [OFF...CChg#95]

Select the modulation source such as LFO or aftertouch (see 6.3 Modulation Source List) that will modulate the output level of the carrier.

5 Level Mod.Int (Carrier Level Modulation Intensity) [-99...+99]

Specify the depth of control that the modulation source specified as the Carrier Level Modulation Source will have on the carrier level. Negative values will invert the polarity of the modulation source.

•PE216 : VPM1 •PE229 : VPM2

OSC1-7 [VPM Cari Shape]

These parameters let you specify the characteristics of the mathematical function that adds high frequencies to the carrier output waveform. The wave shaping function is a sine wave, and its frequency will depend on the Shape value.

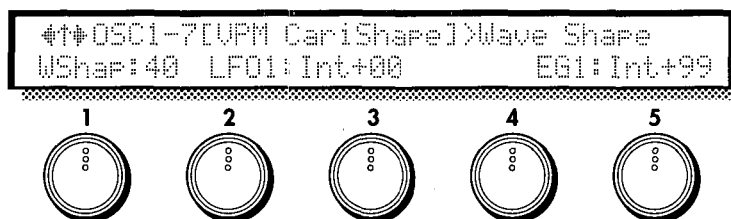

1 Wave Shape (Wave Shape) [0...99]

Increase or decrease the number of cycles in the wave shaping function. Higher values will cause the emphasis to be applied at a higher frequency, and higher partials to be added.

•PE217 : VPM1 •PE230 : VPM2

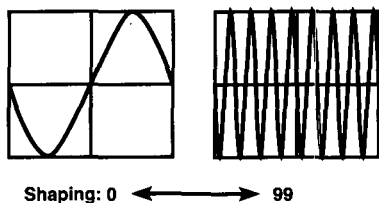

2 Shape Mod.LFO (Wave Shape Modulation LFO) [LFO1...4]

Select the modulation LFO for Wave Shape. This will produce an effect similar to wah or sync modulation. For LFO settings, refer to the LFO section (p.118).

3 Mod.LFO Int (Wave Shape Mod. LFO Intensity) [-99...+99]

Specify the depth and direction of the Wave Shape modulation applied by the selected Wave Shape Modulation LFO.

•PE218 : VPM1 •PE231 : VPM2

4 Shape Mod.Src (Wave Shape Modulation Source) [OFF...CChg#95]

Select a source such as EG or Aftertouch that will modulate Shape. (Refer to 6.3 Modulation Source List.)

5 Shape Mod.Int (Wave Shape Mod. Intensity) [-99...+99]

Specify the depth and direction of the Wave Shape modulation applied by the selected Wave Shape Modulation Source.

•PE219 : VPM1 •PE232 : VPM2

OSC1-8 VPM Feedback Gain

This parameter specifies the amount of the carrier output that will be fed back to the modulation input of the carrier.

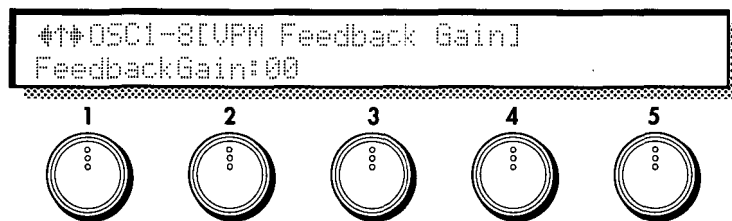

2 VPM Feedback Gain

[0...99]

Specify the input level for the feedback that is returned from the carrier output to the carrier input. The overtone structure will change as this value is increased. Increasing the value beyond a certain amount will result in a noise-like sound.

•PE220 : VPM1 •PE233 : VPM2

OSC1-9 [VPM Modulator Pitch]

These parameters let you make settings related to pitch, keyboard tracking, and modulation source etc. of the modulator:

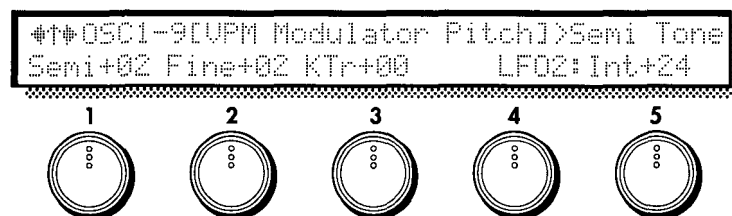

1 Semi Tone

(Frequency Semi Tone)

[-12...+96]

Set the pitch of the modulator in semitone units. This setting is relative to the pitch of the carrier. The basic pitch of the carrier is determined by the OSC1-1 Basic Pitch parameter.

2 Fine Tune

(Frequency Fine Tone)

[-50...+50]

Make fine adjustments to the modulator pitch. This setting is relative to the pitch of the carrier.

3 Kbd Trk

(Modulator Pitch Keyboard Tracking)

[-99...+99]

Specify how keyboard tracking will affect the modulator pitch. With positive (+) values, notes will be pitched progressively sharper (higher) than the normal pitch as you play above C4, and progressively flatter (lower) than the normal pitch as you play below C4. With negative (-) values, higher notes will be progressively flatter, and lower notes will be progressively sharper.

4 Mod.Src (Modulator Pitch Mod. Source) [OFF...CChg#95]

Select the modulation source that will modulate the pitch of the modulator. (Refer to 6.3 Modulation Source List.) Normally, an EG is used for this purpose.

5 Mod.Int (Modulator Pitch Modulation Intensity) [-99...+99]

Specify the depth and direction of the pitch modulation that is applied to the modulator under the control of the modulation source selected in (Modulator Pitch) Mod.Src. With negative (-) values, the polarity of the modulation source will be inverted.

•PE221 : VPM1 •PE234 : VPM2

OSC1-10 [VPM Modulator]

These parameters select the waveform that will be used as the modulator, and set its level.

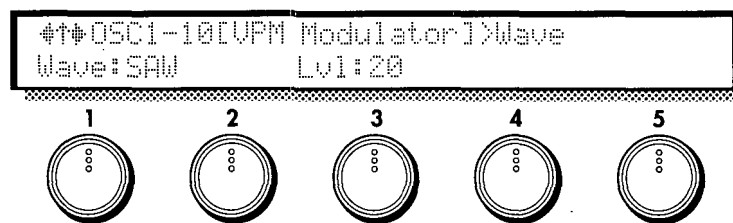

1 Wave (Modulator Wave) [SIN, SAW, TRI, SQU, OSC1/OSC2]

Select the waveform that will be used as the modulator; sine (SIN), sawtooth (SAW), triangle (TRI), square (SQU) wave, or OSC (2 for OSC1, or 1 for OSC2).

•PE222 : VPM1 •PE235 : VPM2

2 Level (Modulator Level) [0...99]

Set the output level of the modulator. With a setting of 0, no modulation will be applied to the carrier. As the value is increased the effect of modulation will intensify.

•PE223 : VPM1 •PE236 : VPM2

OSC1-11 [VPM Modulator Level]

These parameters select the EG modulation source that will control the output level of the modulator.

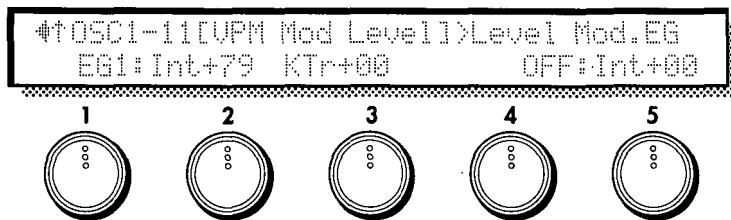

1 Level Mod.EG (Modulator Level Modulation EG) [EG1...4, P.EG, A.EG]

Select the EG that will control the output level of the modulator. For EG settings, refer to p.111 for EG 1-4, p.13 for P.EG, and p.84 for A.EG.

2 Mod.EG Int (Modulator Level Mod. EG Intensity) [-99...+99]

Specify the depth and direction by which the EG selected in Modulator Level Modulation EG will control the modulator output level.

•PE224 : VPM1 •PE237 : VPM2

3 EG Int Kbd Trk (Modulator Level EG Intensity Keyboard Tracking) [-99...+99]

Specify the depth and direction by which keyboard tracking will affect the EG control over modulator output level. With positive (+) settings, the effect of the EG will increase as you play further above the C4 key, and decrease as you play further below the C4 key. With negative (-) settings, the effect of the EG will decrease above the C4 key, and increase below the C4 key.

4 Level Mod.Src (Modulator Level Modulation Source) [OFF...CChg#95]

Specify the modulation source that will affect the output level of the modulator. (Refer to 6.3 Modulation Source List.)

5 Level Mod.Int (Modulator Level Mod. Intensity) [-99...+99]

Specify the depth and direction by which the modulation source specified in Modulator Level Modulation Source will affect the modulator. With negative (-) settings, the polarity of the modulation source will be inverted.

•PE225 : VPM1 •PE238 : VPM2

Cross/Sync/Ring Modulation Oscillator

This oscillator allows you to select one of three types of modulation commonly used in analog synthesizers; sync, cross, and ring modulation.

The modulation oscillator contains a carrier oscillator. This carrier waveform will be modulated. The modulator waveform is not built-in, and you must select an output such as OSC1 as the modulation input. The modulation oscillator is fixed at OSC2.

* These parameters will be displayed when Set 4,7, or 9 has been selected in page OSC-com1 [Oscillator Set].

Carrier

The frequency and/or amplitude of this waveform is modulated by a modulator. All waveforms built into the Modulation Oscillator are used as carriers.

Modulator

In general, "modulator" refers to a waveform which modulates the frequency and/or amplitude of a carrier. The Modulator Oscillator does not contain a modulator; it must be supplied from an external source through the modulation input.

Modulation input

This selects the source of the modulator waveform. Select a modulator from the following three choices.

1. The output waveform of OSC1 (This will depend on the oscillator that is selected for OSC1.)
2. Noise
3. Feedback (This is the waveform that passes through the filter and amp and is output from the Prophecy synthesizer, and will vary widely depending on the settings.)

SYNC MODULATION

The modulator will be the master waveform, and the carrier the slave waveform which will synchronize to the master.

When the master waveform begins a new cycle (i.e., the moment it crosses the zero value line going from positive to negative), the phase of the slave waveform will be reset to 0 and it will begin a new cycle. Either sawtooth or triangle can be selected as the slave waveform. This is usually used with a pitch envelope etc. applied to the master waveform.

Sync Modulation

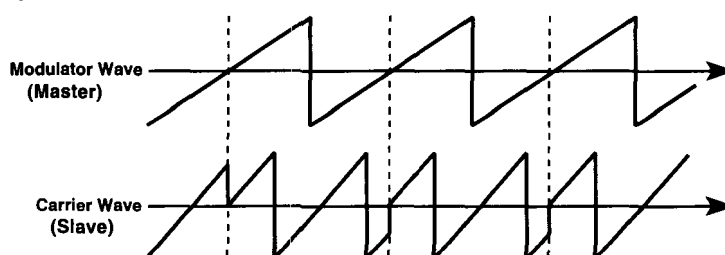

CROSS MODULATION

The modulator applies frequency modulation to the carrier. One of the following 3 waveforms can be selected as the carrier: sawtooth, sine, and square wave. This is usually used with a pitch envelope applied to the modulator.

Cross Modulation

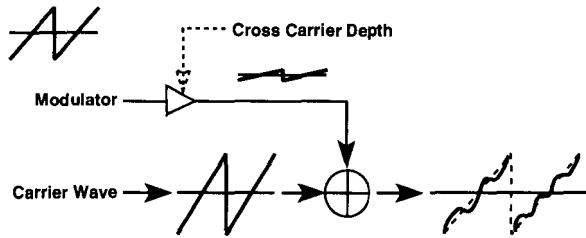

RING MODULATION

The output signal will consist of the product of the modulator and carrier. One of the following 3 waveforms can be selected as the carrier; sawtooth, sine, and square wave. Since ring modulation produces a metallic sound with little pitch content, it is suitable for special effects. Changes in tone are created by the differences in frequency between the carrier and modulator.

Ring Modulation

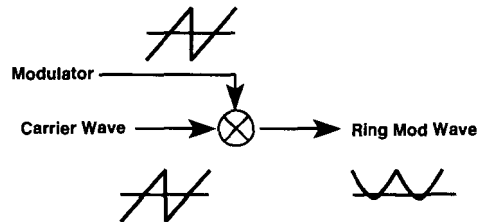

* The pitch of the carrier (the waveform built into the Modulation Oscillator) is determined by OSC1-1 Basic Pitch. The pitch etc. of the modulator (OSC1, SUB OSC) is adjusted by the parameters for OSC1 or SUB OSC.

OSC2-5 [MOD OSC Type]

These parameters determine the modulation type and modulator input.

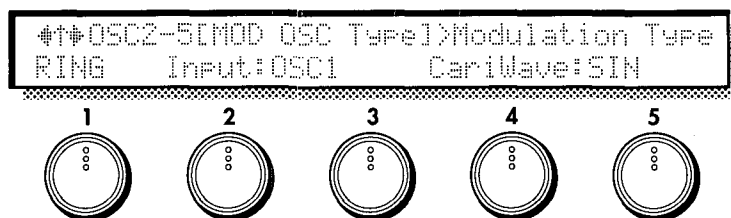

1 Modulation Type [RING, CROSS, SYNC]

Select the type of modulation; RING (ring modulation), CROSS (cross modulation), or SYNC (sync modulation). For an explanation of each type, refer to the p.36.

2 Input Select [OSC1, FBACK, NOISE]

Select the modulator used for modulation.

OSC1 : The output waveform of OSC1 (This will depend on the oscillator that is selected for OSC1.)

FBACK : Feedback (This is the waveform that passes through the filter and amp and is output from the Prophecy synthesizer, and will vary widely depending on the settings.)

NOISE : Noise

RING MODULATION: This will be displayed if the Modulation Type has been set to RING.

4 Carrier Select (Ring Carrier Select) [SIN, SAW, SQU]

Select the waveform of the carrier (the modulation oscillator of the two waveforms that are multiplied) used for ring modulation; SIN (sine), SAW (sawtooth), or SQU (square).

•PE239

CROSS MODULATION: This will be displayed if the Modulation Type has been set to CROSS.

4 Carrier Select (Cross Carrier Select) [SIN, SAW, SQU]

Select the waveform of the carrier for cross modulation; SIN (sine), SAW (sawtooth), or SQU (square).

•PE240

SYNC MODULATION: This will be displayed if the Modulation Type has been set to SYNC.

4 Sync Slave Select (Sync Carrier Select) [SAW, TRI]

Select the carrier (slave) waveform used for sync modulation; SAW (sawtooth) or TRI (triangle).

5 Modulator Edge [0...99]

This parameter controls the amount of overtones in the slave waveform. In cases such as when a pitch envelope etc. raises the slave waveform to a high pitch, set this parameter to a low value to prevent unpleasant overtones from being produced.



As this parameter is adjusted toward 0 the volume will decrease, and at 0 there will be silence. The effect of this parameter is most noticeable for high pitches of the slave waveform, and at low pitches it will have less effect.



When high pitches are played using Sync Modulation, the volume may decrease, and in some cases there may be no sound.

OSC2-6 [Modulator Cross Modulation]

Cross Modulation allows you to specify the depth at which the modulator will apply frequency modulation to the carrier, and specify how the cross modulation will be controlled by EG and by a selected modulation source.

These parameters are displayed when CROSS has been selected for OSC2-5 Modulation Type.

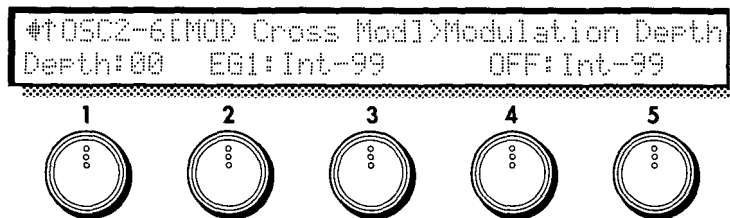

1 **Modulation Depth** (Cross Modulation Depth) [0...99]

Adjust the depth at which the modulator will apply frequency modulation to the carrier. Higher values will produce heavier modulation.

•PE241

2 **Mod.Depth Mod.EG** (Cross Modulation Depth Modulation EG) [EG1...EG4, P.EG, A.EG]

Select the EG that will control the depth of cross modulation. For EG 1~4 settings, refer to the EG section.

3 **EG Intensity** (Cross Modulation EG Intensity) [0...99]

Adjust the depth at which the EG will control the amount of cross modulation.

4 **Depth Mod.Source** (Cross Modulation Depth Modulation Source) [OFF...CChg#95]

Select a modulation source that will control the depth of cross modulation. (Refer to 6.3 Modulation Source List.)

5 **Depth Mod.Int** (Depth Modulation Intensity) [+99...-99]

Specify the depth and direction in which the modulation source specified for Cross Modulation Depth Modulation Source will affect cross modulation depth.

Brass Model Oscillator

This oscillator is a physical model that simulates a lip reed instrument such as a trumpet. By using controllers such as key velocity or the wheel to control Pressure (the force of breath applied to the mouthpiece), you can achieve performance expression similar to an actual lip reed instrument. By modulating the characteristics of the reed, you can create tonal changes like those produced by different playing techniques.

The parameters are divided into three groups: Pressure, which corresponds to the force of the breath that is blown into the mouthpiece; Lip, which creates tonal change corresponding to the shape and tension of the musician's lips; and Bell, which adjusts the tonal characteristics dependent on the shape of the end of the instrument's bore.

This oscillator provides two types of pitch bending; Jump Bending which produces mode jumps as on a trumpet (when valves are used to change the length of the bore), and Smooth Bending as on a trombone (when the length of the bore is changed continuously).

Settings for Jump Bend are made in OSC-cmn5 PB Intensity (+) and PB Intensity (-), and settings for Smooth Bend are made using the Smooth Bending parameters of OSC1-5.

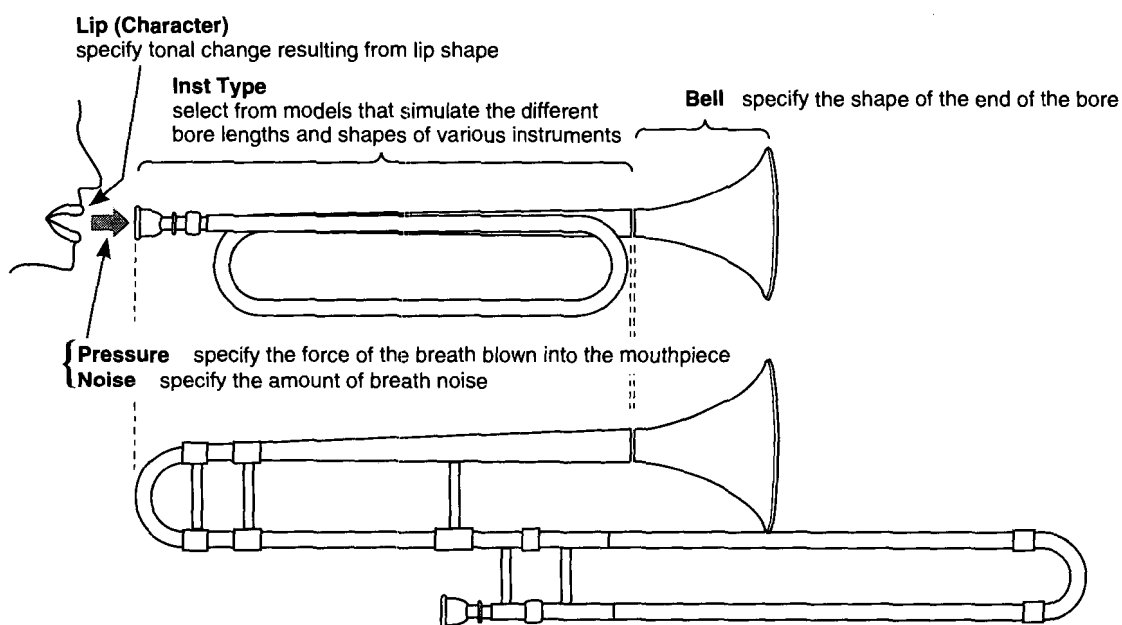

⚠ For some parameter settings, the resulting pitch may not match the pitches of the keyboard.

⚠ When high pitches are played, the volume may decrease, and in some cases there may be no sound.

* These parameters are displayed if Set 10 has been selected in page OSC-cmn1 [Oscillator Set].

OSC1-5 [Brass Type]

These parameters let you select the instrument type and make settings for Smooth Bending.

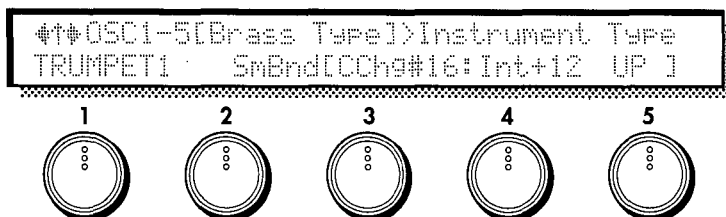

1 Instrument Type [TRUMPET1, TRUMPET2, TROMBONE, HORN]

Select the instrument type. This selection determines characteristics of the instrument such as bore length and mouthpiece shape.

3 Smooth Bending Ctl (Smooth Bending Controller) [OFF...CChg#95]

Select the controller that will control the smooth bending effect (Refer to 6.3 Modulation Source List), to create continuous changes in pitch.

For example you could assign Wheel 1 to PBend+ (in Common section page CMN-5 Control Wheel 1) and use it to control Jump Bending, and assign Wheel 2 as the Smooth Bending controller. This would allow you to independently use both types of bending effect in a single program.

4 Smooth Bending Int (Smooth Bending Intensity) [0...12]

Set the bend range of Smooth Bending up to a maximum of 1 octave.

Jump Bend will use the setting of page OSC-cmn5 PB Intensity (+) and PB Intensity (-).

5 Smooth Bending Dir(Smooth Bending Direction) [UP, DOWN, BOTH]

Specify the direction of the pitch bend controlled by the Smooth Bending Controller. If this parameter is set to UP or DOWN, the resulting pitch bend will be zero when the selected Smooth Bending Controller is at zero (minimum) position, and will reach the maximum pitch bend specified by Smooth Bending Intensity when the controller is at 127 (maximum) position.

The pitch will rise with a setting of UP, and fall with a setting of DOWN. If you select BOTH, zero pitch bend will occur when the controller selected as the Smooth Bending Controller is at the center position; the pitch will rise for controller positions above center, and fall for controller positions below center.

For example if you have assigned Aftertouch to be the controller, applying aftertouch to the keyboard will raise the pitch if UP is selected, and will lower the pitch if DOWN is selected. If BOTH is selected, zero pitch bend (standard pitch) will be reached when the aftertouch value reaches the halfway point.

OSC1-6 [Brass Pressure EG]

These parameters determine how EG and modulation source will control Pressure (the force of breath blown into the mouthpiece), and set the level of breath noise.

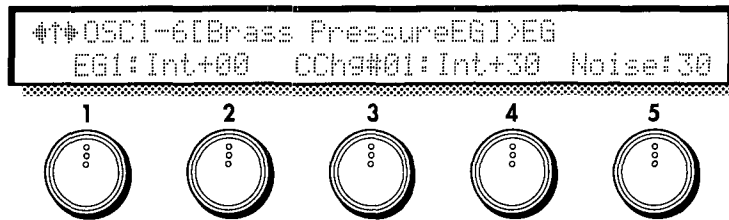

1 EG (Pressure EG) [EG1...4, P.EG, A.EG]

Select the EG that will control Pressure. For EG settings, refer to p.111 for EG 1~4, p.13 for P.EG, and p.84 for A.EG.

2 EG Intensity (Pressure EG Intensity) [-99...+99]

Specify the depth of control that the EG selected as the Pressure EG will have on Pressure.

•PE243

3 Mod.Source (Pressure EG Intensity Modulation Source) [OFF...CChg#95]

Select the modulation source that will control Pressure EG Intensity. (Refer to 6.3 Modulation Source List.) This will control the effect of the envelope, and by selecting LFO you can simulate the vibrato that a brass player produces by varying the pressure of his breath.

4 Mod.Int (Pressure EG Intensity Mod.Intensity) [-99...+99]

Specify the amount and direction of the change produced by the modulation source selected for Pressure EG Intensity Modulation Source. With positive (+) settings the Pressure Intensity values will be increased, and with negative (-) settings they will be decreased.

5 Noise Level [0...99]

Set the volume level of the breath noise. Since this uses the signal from the noise generator, you can use the low pass filter for the noise generator to adjust the tone of the noise (see page 58).

•PE247

OSC1-7 [Brass Pressure Mod]

These parameters let you make settings for the LFO and modulation source that controls Pressure (the force of the breath blown into the mouthpiece).

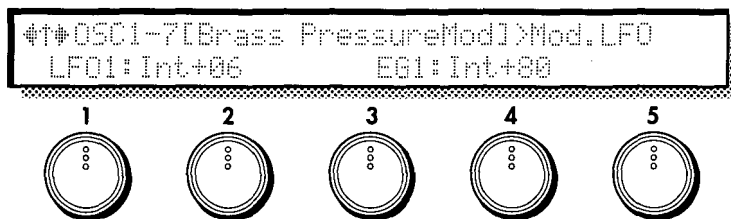

1 Mod.LFO (Pressure Modulation LFO) [LFO1...4]

Select the LFO that will control Pressure. LFO settings are made in the Lfo section. By using aftertouch etc. to control the selected LFO you can apply vibrato in a more natural manner.

2 Mod.LFO Int (Pressure Modulation LFO Intensity) [-99...+99]

Specify the depth of the modulation (vibrato) that will be applied to Pressure by the LFO selected for Pressure Modulation LFO.

3 Mod.Source (Pressure Modulation Source) [OFF...CChg#95]

Select the modulation source that will control Pressure. (Refer to 6.3 Modulation Source List.) If Aftertouch is selected here, breath pressure will increase when you press down on the keyboard. If Modulation Wheel is selected here, breath pressure will increase when you move the wheel in the positive (+) direction. In this case, you can set Pressure EG Intensity (page OSC 1-6,2) to 0, and use only the modulation wheel to control the breath pressure and produce sound.

4 Mod.Int (Pressure Modulation Intensity) [-99...+99]

Specify the depth and direction of the control applied to Pressure by the modulation source selected for Pressure Modulation Source. With positive (+) settings, higher values of the Pressure Modulation Source will increase the Pressure. With negative (-) settings, lower values of the Pressure Modulation Source will increase the Pressure. If EG or LFO is selected as the Pressure Modulation Source, positive (+) settings will cause the original phase of the EG or LFO to be used, and negative (-) settings will invert the phase.

* Selecting LFO as the Pressure EG Intensity Modulation Source (page OSC 1-6,4) is not the same thing as using the Pressure Modulation LFO. The former simulates the effect of the Pressure EG (page OSC 1-6,4), and the LFO effect is proportionate to the value of the EG signal. This means that if the EG signal is 0, there will be no effect. The latter (Pressure Modulation LFO) applies an LFO effect that is independent of the EG, so the Pressure value will still be modulated even if the EG signal is 0.

OSC1-8 [Brass Lip]

These parameters simulate how the lips vibrate, and specify how changes in lip position and tension create changes in tone color.

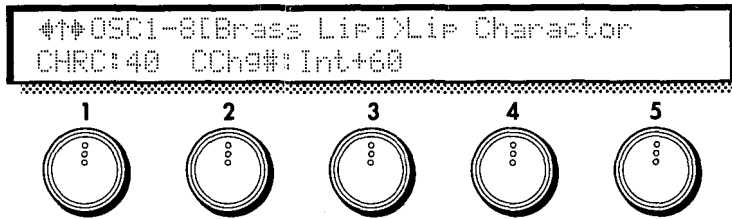

1 Lip Character [0...99]

Adjust the difference in tone that results from lip tension or pressure. Higher settings will produce a harder (more strongly played) tone, and lower settings will produce a more mellow sound.

•PE244

2 Character Mod.Src (Lip Character Modulation Source) [OFF...CChg#95]

Select the modulation source that will control Lip Character. (Refer to 6.3 Modulation Source List.)

3 Character Mod.Int (Lip Character Mod.Intensity) [-99...+99]

Specify the depth and direction of the effect produced by the modulation source selected for Lip Character Modulation Source. With positive (+) settings, higher values of the Lip Character Modulation Source will increase the Lip Character value. With negative (-) settings, higher values of the modulation source will decrease the Lip Character value. If EG or LFO is selected as the Pressure Modulation Source (page OSC 1-7,3), positive (+) settings will cause the original phase of the EG or LFO to be used, and negative (-) settings will invert the phase.

OSC1-9 [Brass Bell]

These parameters determine how the bell (bore end) of the brass instrument will affect the tone.

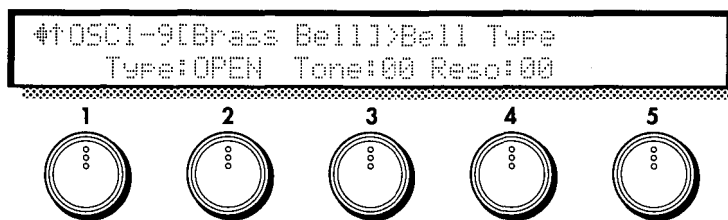

2 Bell Type

[OPEN, MUTE]

Specify the type of the bell. A setting of MUTE simulates the characteristic tone that occurs when a hand or a plastic mute is inserted into the bell to attenuate the acoustical output. A setting of OPEN is the normal state.

3 Bell Tone

[0...99]

Adjust the tone of the bell. As this value is increased, the lower frequency range will decrease, producing a thinner tone.

•PE245

4 Bell Resonance

[0...99]

Adjust the level of emphasis that is applied at the frequency region specified by the Bell Tone setting. As this value is increased the resonance effect will be emphasized.

•PE246

Reed Model Oscillator

This oscillator is a physical model simulation of a reed instrument such as a saxophone or oboe, etc.

By using a controller such as key velocity or modulation wheel to control Pressure (the force of blowing), you can simulate the performance expression that is characteristic of a woodwind instrument.

By controlling the characteristics of the reed, you can produce the tonal changes that result from differences in blowing techniques.

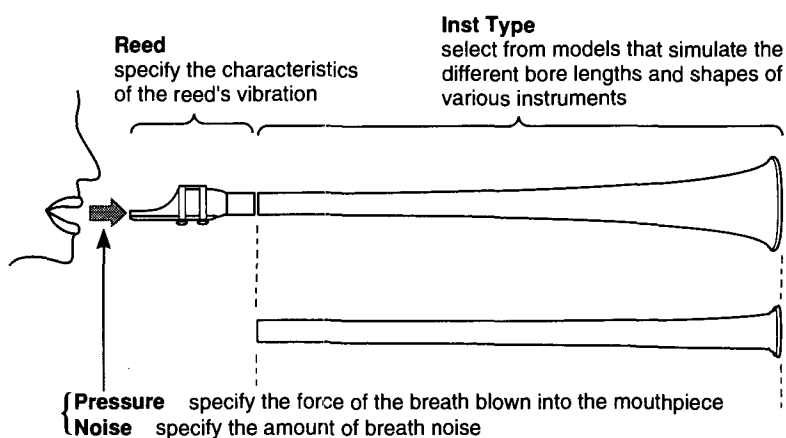

⚠ Some parameter settings may cause the pitch to deviate from the normal pitch of the keyboard.

⚠ When high pitches are played, the volume may decrease, and in some cases there may be no sound.

These parameters will be displayed when Set 11 is selected for page OSC-cmn1 Oscillator Set.

OSC1-5 [Reed Type]

These parameters allow you to select the instrument type, and make settings related to Smooth Bending.

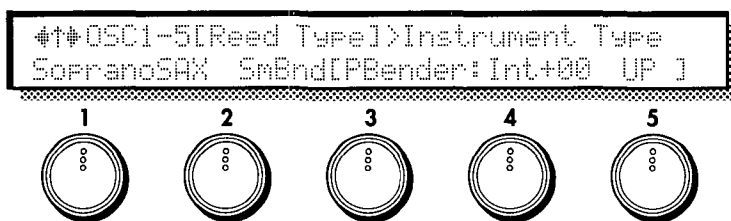

1 Instrument Type

[SopranoSAX...MONSTER]

Select the instrument type. This selection determines the shape of the bore and the characteristics of the reed. Thirteen types are available; SopranoSAX, AltoSAX1, AltoSAX2, TenorSAX1, TenorSAX2, BaritoneSAX, FLUTE, SingleREED, DoubleREED, RECORDER, BOTTLE, GLASS BOTTLE, and MONSTER.

3 Smooth Bending Ctl (Smooth Bending Control)

[OFF...CChg#95]

Select the controller that will control the smooth bending effect, to produce unbroken change in pitch. For details on how Jump Bending and Smooth Bending are related, refer to p.41.

4 Smooth Bending Int (Smooth Bending Intensity)

[0...12]

Specify the range of Smooth Bending (up to one octave).

5 Smooth Bending Dir (Smooth Bending Direction)

[UP, DOWN, BOTH]

Specify the direction of the pitch bend controlled by the Smooth Bending Controller. If this parameter is set to UP or DOWN, the resulting pitch bend will be zero when the selected Smooth Bending Controller is at zero (minimum) position, and will reach the maximum pitch bend specified by the Smooth Bending Intensity setting when the controller is at 127 (maximum) position.

For details on the parameter values, refer to p.41.

OSC1-6 [Reed Pressure EG]

These parameters let you select the EG that will control Pressure (the force of breath blown into the reed) and specify a modulation source for it, and set the level of breath noise.

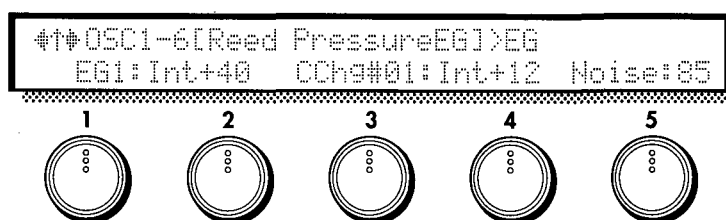

1 EG

(Pressure EG)

[EG1...4/P.EG/A.EG]

Select the EG that will control Pressure. For EG settings, refer to p.111 for EG 1~4, p.13 for P.EG, and p.84 for A.EG.

2 EG Intensity

(Pressure EG Intensity)

[0...99]

Set the depth of the effect that the EG selected for Pressure EG will have on Pressure.

•PE248

3 Mod.Source

(Pressure EG Intensity Modulation Source)

[OFF...CChg#95]

Select the modulation source that will control Pressure EG Intensity. (Refer to 6.3 Modulation Source List.) The selected modulation source will control the effect that the envelope has on Pressure. If you select LFO as the modulation source, you can simulate the vibrato or growl effects produced on a wind instrument by varying breath pressure.

4 Mod.Intensity

(Pressure EG Intensity Modulation Intensity)

[-99...+99]

Specify the depth and direction of the effect produced by the modulation source selected as the Pressure EG Intensity Modulation Source. With positive (+) settings, higher values of the modulation source will increase the Pressure EG Intensity value. With negative (-) settings, higher values of the modulation source will decrease the Pressure EG Intensity value.

5 Noise Level

[0...99]

Set the volume level of the breath noise. Since this uses the signal from the noise generator, you can use the low pass filter for the noise generator to adjust the tone of the noise (see p.58).

•PE250

OSC1-7 [Reed PressureMod] - Reed Pressure Modulation

These parameters let you make settings for the LFO that controls Pressure (the force of breath blown into the reed), and specify a modulation source to control it.

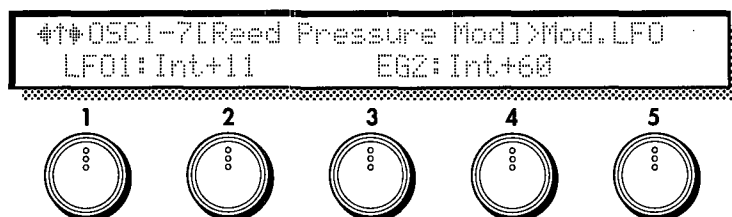

1 Mod.LFO (Pressure Modulation LFO) [LFO1...4]

Select the LFO that will control Pressure. Make settings for these LFOs in the LFO section. By using Aftertouch etc. to control this LFO, you can create more natural vibrato or growl effects.

2 Mod.LFO Int (Pressure Modulation LFO Intensity) [-99...+99]

Specify the depth of the modulation (vibrato) effect that the LFO selected as the Pressure Modulation LFO will apply to Pressure.

3 Mod.Source (Pressure Modulation Source) [OFF...CChg#95]

Select the modulation source that will control Pressure. (Refer to 6.3 Modulation Source List.) This allows you to increase Pressure (the force of breath) by pressing down on the keyboard (if Aftertouch is selected here) or by moving a modulation wheel in the (+) direction (if the Wheel controller is selected). For this parameter, the selected modulation OSC source (wheel, etc.) can be used to control breath pressure even if the Pressure EG Intensity (page OSC 1-6,2) is 0.

4 Mod.Int (Pressure Modulation Intensity) [-99...+99]

Specify the depth and direction of the effect that the selected Pressure Modulation Source will have on Pressure. With positive (+) settings, higher values of the modulation source will increase the Pressure value. With negative (-) settings, lower values of the modulation source will increase the Pressure value. If EG or LFO has been selected as the Pressure Modulation Source, positive (+) settings will cause the original phase of the EG or LFO to be used, and negative (-) settings will invert the phase.

* Selecting an LFO as the Pressure EG Intensity Modulation Source (page OSC 1-6,4) is not the same as using the Pressure Modulation LFO. The former simulates the effect of the Pressure EG (page OSC 1-6,4), and the effect of the LFO will depend on the value of the EG signal. This means that if the EG signal is 0, there will be no effect. The latter (Pressure Modulation LFO) applies an LFO effect that is independent of the EG, so the Pressure value will still be modulated even if the EG signal is 0.

OSC1-8 [Reed Reed Mod]

These parameters let you make settings for reed resonance and the modulation source that will control it.

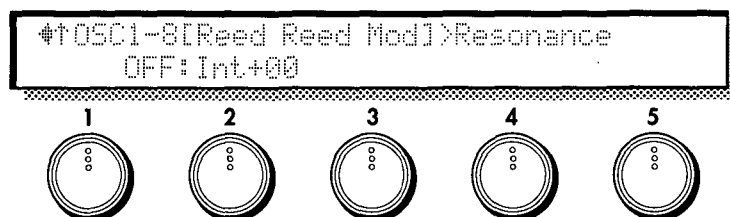

1 **Mod.Source** (Reed Modulation Source) [OFF...CChg#95]

Select a modulation source that will modulate the changes in the reed. (Refer to 6.3 Modulation Source List.)

2 **Mod.Intensity** (Reed Mod. Intensity) [-99...+99]

Set the depth of the effect that the selected Reed Modulation Source will have on the reed.

•PE249

Pluck Oscillator

This oscillator is mainly for creating electric bass sounds.

You can adjust the attack waveform that occurs when the string is plucked by pick or finger, and make settings affecting the condition of the string and the position of the string at which it is plucked.

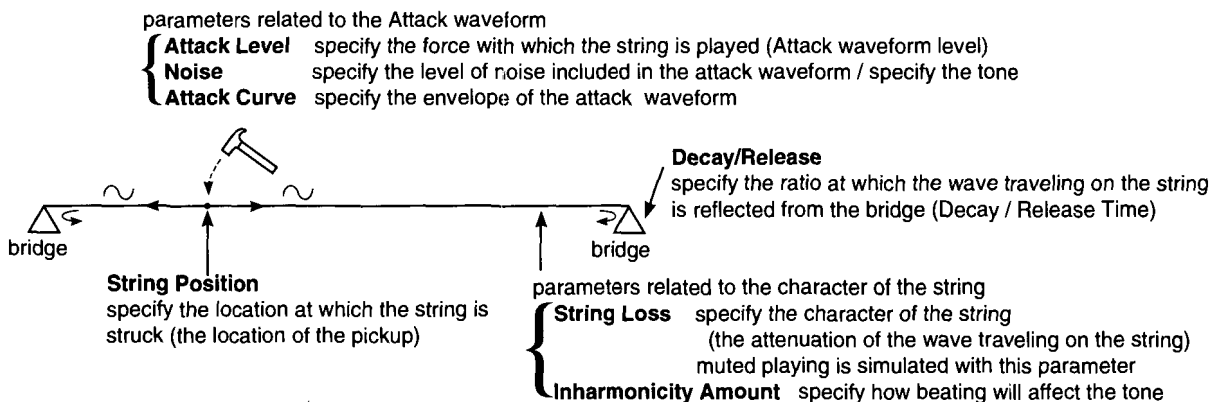

* These parameters will be displayed if Set 12 has been selected in page OSC-cmn1 [Oscillator Set].

OSC1-5 [Pluck Attack]

These parameters control the force with which the string is plucked, the way that velocity will affect it, and the Attack Noise settings that determine the amount and tone color of the noise component that is added to the attack sound by the characteristics of the pick or finger that plucks the string.

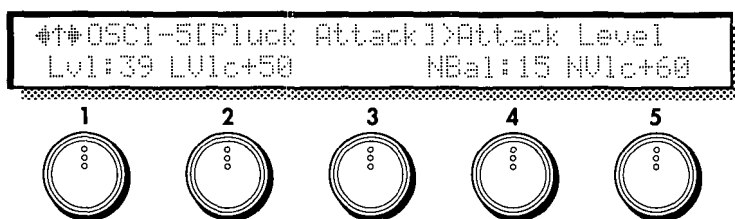

1 Attack Level [0...99]

Set the force at which the string is plucked.

2 Attack Veloc Ctl (Attack Level Velocity Control) [-99...+99]

Set the depth and direction of the change in Attack Level that is controlled by velocity.

4 Noise Balance (Attack Noise Balance) [0...99]

Adjust the balance of the noise component included in the attack sound. As this value is increased, there will be proportionally more noise in the attack, and the sound will be more brilliant with more overtones.

5 Noise Lvl VelCtl (Attack Noise Level Velocity Control)

[-99...+99]

Specify the depth and direction of the effect that velocity will have on the level of noise that is included in the attack.

OSC1-6 [Pluck Noise Filter]

These parameters determine the tone color of the noise component included in the attack, simulating the characteristics of the pick or finger that plucks the string.

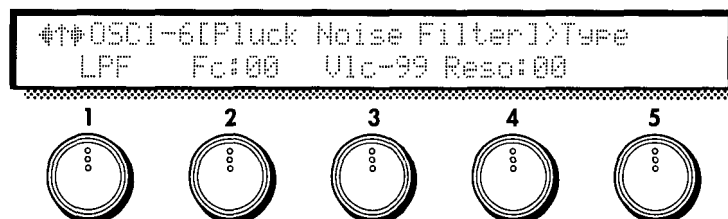

1 Type (Attack Noise Filter Type) [LPF, HPF, BPF]

Select the type of filter that will process the attack noise; LPF (low pass filter), HPF (high pass filter), or BPF (band pass filter). For details on the various types of filter, refer to Filter Section page FL1-1 [Type & Input].

2 Fc (Attack Noise Filter Fc) [0...99]

Set the cutoff frequency at which the filter will process the attack noise.

•PE252

3 Fc VelCtl (Attack Noise Filter Fc Velocity Control) [-99...+99]

Set the depth and direction with which velocity will affect the Attack Noise Filter Fc (frequency).

4 Resonance (Attack Noise Filter Resonance) [0...99]

Set the degree to which the frequency range in the area of the Attack Noise Filter Fc setting will be emphasized.

OSC1-7 [Pluck Attack Curve]

These parameters determine the envelope of the attack sound. By using velocity to control these settings you can achieve more lifelike changes in tone.



1 Up (Attack Curve Up) [0...99]

Set the steepness of the rising edge of the attack waveform. As this value is increased the rising edge will become steeper, making it easier to produce hard attack sounds.

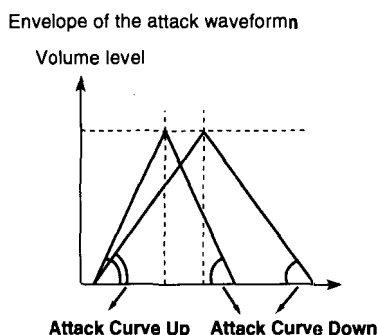

2 Up Vel Ctl (Attack Curve Up Velocity Control) [-99...+99]

Specify the depth and direction of the effect that velocity will have on Attack Curve Up. With positive (+) settings, the ascending edge will become steeper as you play more strongly. With negative (-) settings, the ascending edge will become less steep as you play more strongly.

3 Down (Attack Curve Down) [0...99]

Set the steepness of the falling edge of the attack waveform. As this value is increased, the falling edge will become steeper.

4 Down Vel Ctl (Attack Curve Down Velocity Control) [-99...+99]

Specify the depth and direction of the effect that velocity will have on Attack Curve Down. With positive (+) settings, the descending edge will become steeper as you play more strongly. With negative (-) settings, the descending edge will become less steep as you play more strongly.

5 Edge (Attack Edge) [0...99]

Set the overall hardness of the sound of the attack waveform. As this value is increased, the edge effect will intensify.

OSC1-8 [Pluck String Position]

These parameters set the position at which the string is plucked.

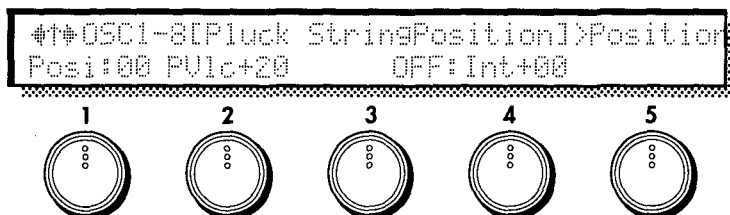

1 Position (String Position) [0...99]

Set the location at which the string is plucked and the location of the pickup. Increasing this value will simulate a pluck closer to the bridge.

•PE253

2 Vel Ctrl (String Position Velocity Control) [-99...+99]

Set the depth and direction of the effect that velocity will have on String Position.

3 Mod.Src (String Position Modulation Source) [OFF...CChg#95]

Select the modulation source that will control String Position. (Refer to 6.3 Modulation Source List.)

4 Mod.Int (String Position Modulation Intensity) [-99...+99]

Set the depth and direction of the effect that the selected String Position Mod.Source will have on String Position. With positive (+) settings, higher values of the modulation source will increase the String Position value. With negative (-) settings, lower values of the modulation source will increase the String Position value. If EG or LFO has been selected as the String Position Modulation Source, positive (+) settings will cause the original phase of the EG or LFO to be used, and negative (-) settings will invert the phase.

OSC1-9 [Pluck String Loss]

These parameters affect the way in which the string vibrates.

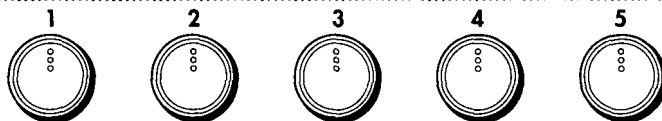

1 String Loss [0...99]

The setting of this parameter determines how vibration will pass through the string, and how high frequency components will be attenuated by the bridge and finger (pressing the string), etc. As this value is increased, the high frequencies will be attenuated more heavily, making the tone darker. Conversely, as this value is lowered, there will be less attenuation of the high frequency components, producing a brighter tone.

•PE254

2 Kbd Track [-99...+99]

(String Loss Keyboard Tracking)

Specify how keyboard position will affect String Loss. With positive (+) settings, playing above the C4 key will progressively increase the String Loss. With negative (-) settings, playing above the C4 key will progressively decrease the String Loss.

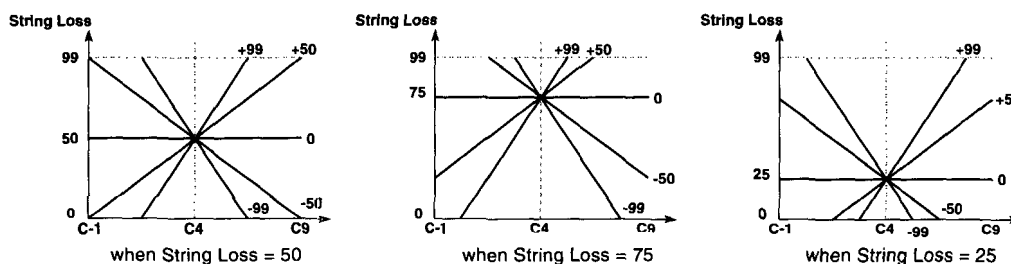

3 Mod.Source [OFF...CChg#95]

(String Loss Modulation Source)

Select the modulation source that will control String Loss. (Refer to 6.3 Modulation Source List.)

4 Mod.Int [-99...+99]

(String Loss Modulation Intensity)

Specify the depth and direction of the effect that the selected String Loss Modulation Source will have. With positive (+) settings, higher values of the modulation source will increase the String Loss value. With negative (-) settings, lower values of the modulation source will increase the String Loss value. If EG or LFO has been selected as the String Loss Modulation Source, positive (+) settings will cause the original phase of the EG or LFO to be used, and negative (-) settings will invert the phase.

OSC1-10 [Pluck Inharmonicity]

These parameters affect the beating of the string.

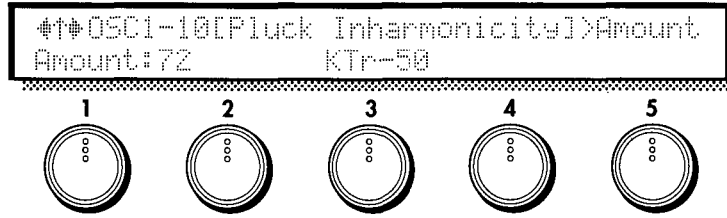

1 Amount (Inharmonicity Amount) [0...99]

Specify the amount of inharmonicity. As this value is increased, the string will beat more deeply.

•PE255



Some String Loss and Inharmonicity Amount settings may cause the pitch to deviate from the standard pitch. In such cases, use the respective keyboard tracking parameters to compensate for the pitch deviation, or initialize the settings to Initial Source (page OSCU-2) #32:Plucked, and edit the sound once again.

2 KbdTrack (Inharmonicity Keyboard Tracking) [-99...+99]

Specify how Inharmonicity Amount will be adjusted according to the keyboard position of the note. For positive (+) settings, the Inharmonicity Amount value will be increased for notes above C4. For negative (-) settings, the Inharmonicity value will be decreased for notes above C4.

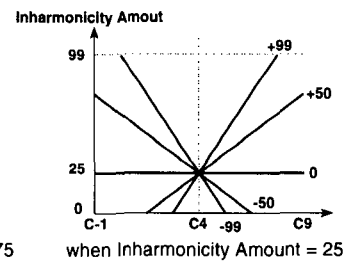
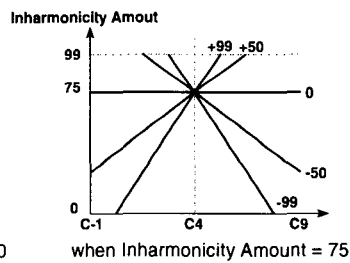
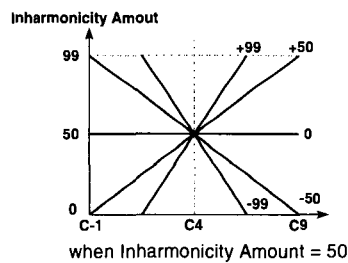

OSC1-11 [Pluck Decay & Release]

These parameters determine the Decay Time over which the sound decays while you continue holding a note, and the Release Time over which the sound will disappear when you release a note. You can also specify how keyboard position will affect these parameters.

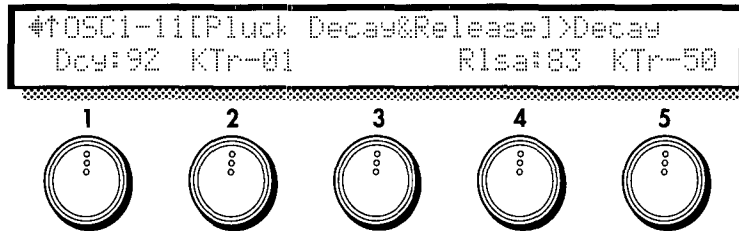

1 Decay [0...99]

Specify the Decay Time over which the sound will decay while you continue holding a note. Higher settings will produce a longer decay time.

! Depending on the settings of the Amplitude Modulation EG (page Amp 1-2,1 / Amp 2-2,1), this Release setting may have no effect. If the Break Level and Sustain Level of the EG are raised, the effect of this setting will be easier to hear.

2 DcyKbdTrk (Decay Keyboard Tracking) [-99...+99]

Specify how keyboard position will affect the Decay Time. Positive (+) settings will slow down the decay as you play above the C4 key, and negative (-) settings will speed up the decay.

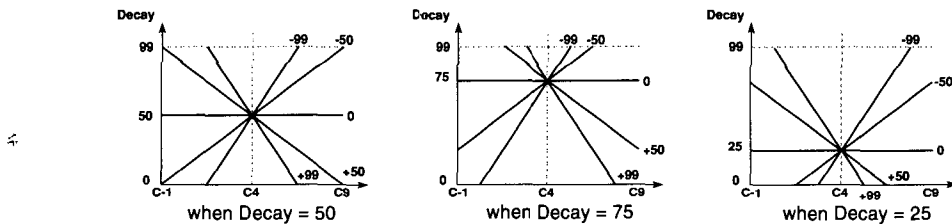

4 Release [0...99]

Specify the Release Time over which the sound will disappear when you release a note. Higher settings will produce longer release times.

! Depending on the settings of the Amplitude Modulation EG (page Amp 1-2,1 / Amp 2-2,1), this Release setting may have no effect. Setting the EG Release Time to a longer value will allow the effect of this Release setting to be more apparent.

5 RlsKbdTrk (Release Keyboard Tracking) [-99...+99]

Specify how keyboard position will affect the Release. Positive (+) settings will slow down the release as you play above the C4 key, and negative (-) settings will speed up the release.

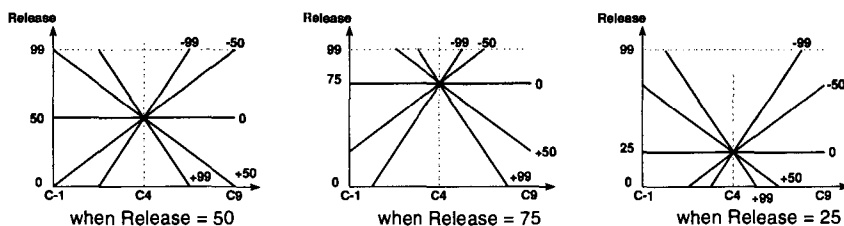

SUB Oscillator

The sub oscillator allows you to choose one of four basic waveforms, and make it track the pitch of either oscillator 1 or 2 at an interval that you specify in semitone steps and cents. This means that the sub oscillator will share the same pitch modulation effects as the selected oscillator.

In the Mixer section, the signal from the sub oscillator is mixed with the signals of oscillators 1 and 2.

SUB OSC-1 [Sub OSC]

These parameters select the waveform of the sub oscillator, and set its pitch.

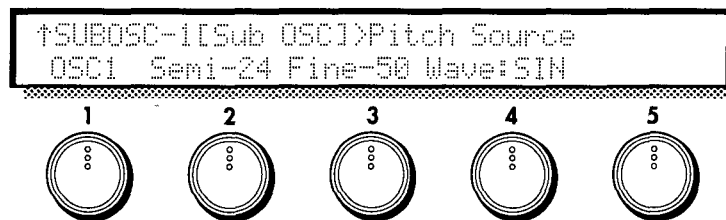

1 Pitch Source [OSC1, OSC2]

Specify either OSC1 or 2 as the basis for the pitch of the sub oscillator.

2 Relative Semi Tone [-24...+24]

Specify a pitch interval in semitones between the sub oscillator and the selected Pitch Source oscillator. With a setting of (for example) +12, the sub oscillator will produce a pitch one octave above the selected Pitch Source oscillator.

•PE24

3 Relative Fine Tune [-50...+50cent]

Specify a fine adjustment to the pitch interval in steps of 1/100 semitone (1 cent).

•PE25

4 Wave Form [SIN, SAW, SQU, TRI]

Select the waveform of the sub oscillator.

•PE26

Noise Generator

The noise generator produces white noise. In the Mixer section, the generated noise is mixed with the signals from oscillator 1 and 2, in the same way as the sub oscillator.

NOISE-1 [Noise Generator]

These parameters set the cutoff frequency of the noise generator and specify how keyboard position will affect the noise.

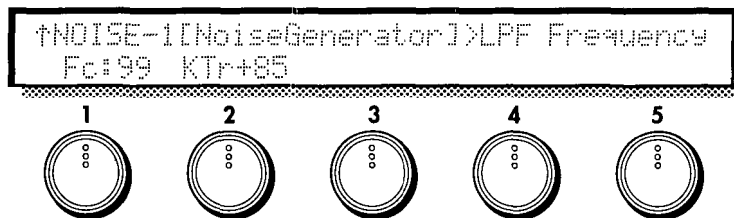

1 LPF Frequency (Noise LPF Frequency) [0...99]

Set the cutoff frequency of the low pass filter which is applied to the output of the noise generator. With low settings of this parameter, the high frequencies of the noise will be cut, producing a darker sound.

•PE27

2 LPF Freq KbdTrk (Noise LPF Frequency Keyboard Tracking) [-99...+99]

Specify how keyboard position will affect the Noise LPF Frequency.

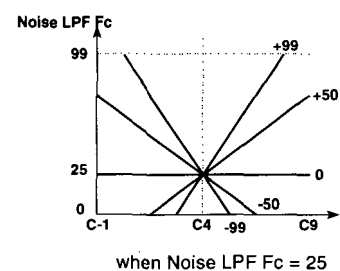
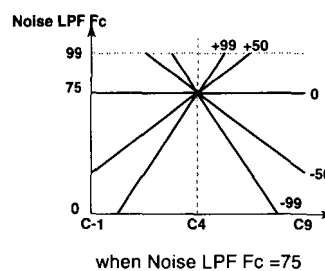
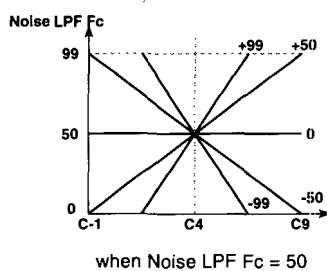

[UTY] - Utility

OSCU-1 [Initialize]

This command initializes the oscillator.

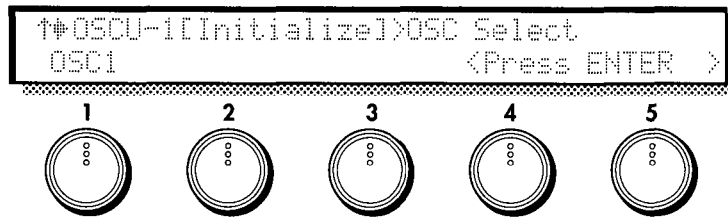

1 OSC Select (Oscillator select) [OSC1, OSC2, ALL]

The oscillator will be initialized to a setting that is appropriate for the currently selected oscillator type (including Modulation and Inst types). Use this command if the oscillator is no longer sounding properly, or if you wish to start over with your editing with the currently selected oscillator type. If you select OSC1, settings of pages OSC1-5 and following for the oscillator currently selected as OSC1 will be initialized. If you select OSC2, settings of pages OSC2-5 and following for the oscillator currently selected as OSC2 will be initialized. If you select ALL, all of the above settings (OSC1 and OSC2) settings will be initialized.

After selecting the data to be initialized, press the ENTER key to execute.

OSCU-2 [Set Initialize]

This command initializes a specified oscillator set.

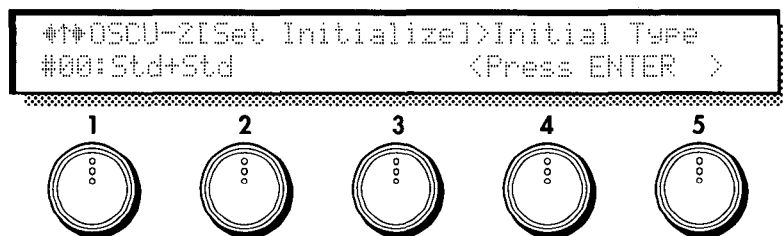

1 Initial Type [#00...32]

This command initializes the oscillator set to a basic setting appropriate for the selected type. Execute this command when you change the oscillator type.

Make the desired selection, and press the ENTER key to execute.

OSCU-3 [COPY]

This command copies the specified block of OSC section settings from another program to the currently selected program.

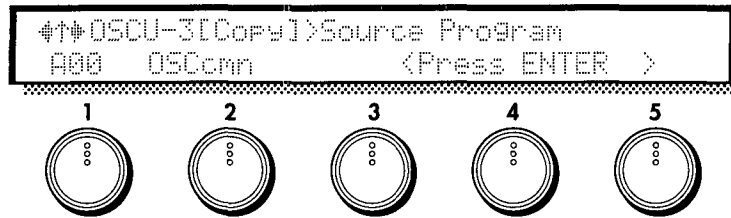

1 Source Program

[A00...C63]

Specify the program number for the copy source.

If you have selected C00~C63 and if no card is inserted, the display will indicate <No Card>, and the operation will be halted. If an unformatted card is inserted, the display will indicate <Illegal Format>, and the operation will be halted.

2 Target Block

[OSCcnn, OSC1, OSC2, SubOSC, NOISE, ALL]

Specify the desired block of OSC section settings that you wish to copy.

If you have selected OSC1 or OSC2 and if the copy source and the current oscillator types are different, the display will indicate <OSC Type Error>, and the operation will be halted.

If you select ALL, the Oscillator Set selection will also be copied.

Make the desired selection, and press the ENTER key to execute.



This page is the last page except for Oscillator Sets 1, 5, and 8.

OSCU-4 [Duplicate]

This command sets oscillators 1 and 2 of the current program to the identical settings.

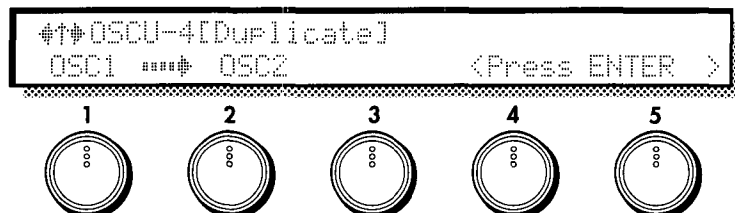

1

(Duplicate Source)

[(OSC1 --> OSC2), (OSC2 --> OSC1)]

For Oscillator Sets 1, 5, and 8, you can set OSC1 and OSC2 to the identical settings. Select the oscillator (at the left) whose settings will be duplicated.

Make the desired selection, and press the ENTER key to execute.

OSCU-5 [Swap]

This command exchanges the settings of oscillators 1 and 2 within the current program.

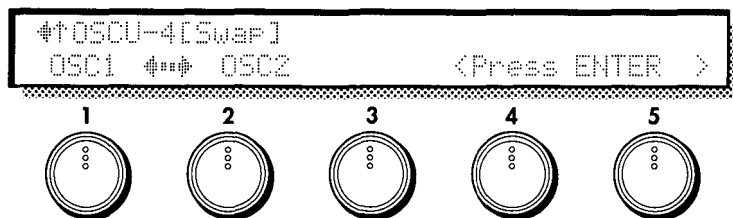

For Oscillator Sets 1, 5, and 8, you can exchange the settings of oscillator 1 and 2.

Press the ENTER key to execute.

4-2. Wave Shape Section

Two independent wave shaping tables are provided, one for each oscillator 1 and 2. These modify the waveform to create elements not originally present, such as resonant or distorted sounds.

The following diagram shows the signal flow in the wave shaping section.

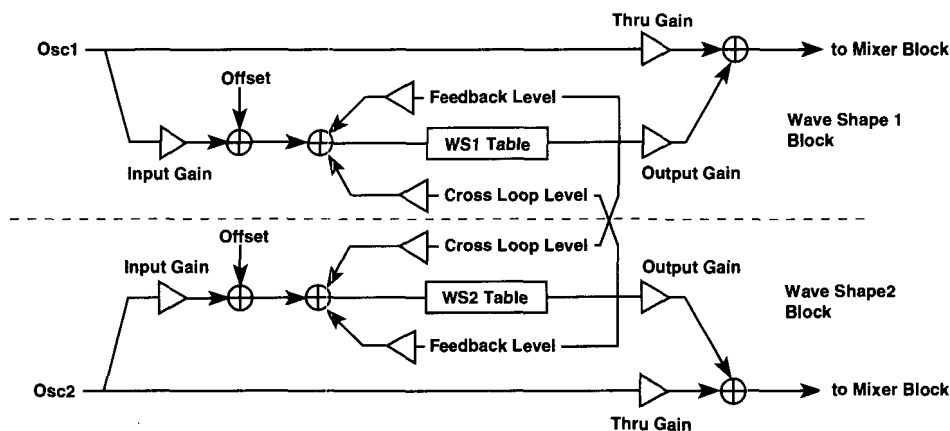

WS-1 [WaveShap Menu]

This is the wave shape menu page.

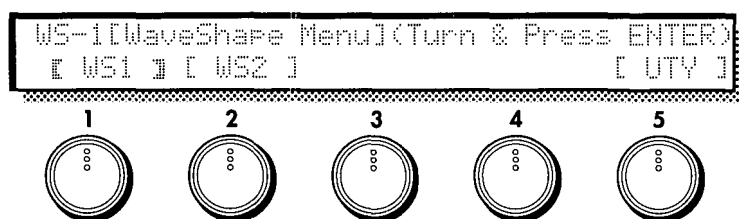

1 [WS1] (Wave Shape 1)

2 [WS2] (Wave Shape 2)

5 [UTY] (Utility)

Select the wave shaping table that you wish to edit, or the wave shaping utilities.

[WS1] and [WS2] make settings for each wave shaping table. [UTY] lets you initialize, copy, and exchange wave shaping table data.

Use the CURSOR keys or the knobs to select the item that you wish to edit, and press the ENTER key to enter the item.

The parameters for [WS2] are identical to those of [WS1]. Refer to the explanations for WS1-1...5.

[WS1]

WS1-1 [Input Gain]

These parameters set the level of the signal from OSC1 that is input to the Wave Shape section, and specify the modulation source etc. that will control the input gain.

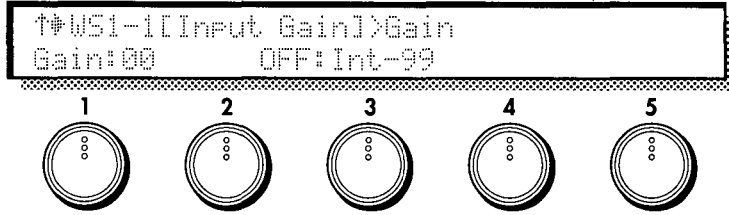

1 Gain (Input Gain) [0...99]

Set the level of the signal that is input from OSC1 to the Wave Shape section.

•PE169 : WS1 •PE176 : WS2

2 Mod.Source (Input Gain Modulation Source) [OFF...CChg#95]

Select the modulation source that will control the Input Gain. (Refer to 6.3 Modulation Source List.)

3 Mod.Intensity (Input Gain Mod.Intensity) [-99...+99]

Set the depth and direction in which the selected Input Gain Modulation Source will affect the Input Gain. With positive (+) settings, higher values of the modulation source will increase the Input Gain. With negative (-) settings, lower values of the modulation source will increase the Input Gain. If EG or LFO has been selected as the Input Gain Modulation Source, positive (+) settings will cause the original phase of the EG or LFO to be used, and negative (-) settings will invert the phase.

•PE170 : WS1 •PE177 : WS2

An example of changing the Input Gain (Table Type: Reso)

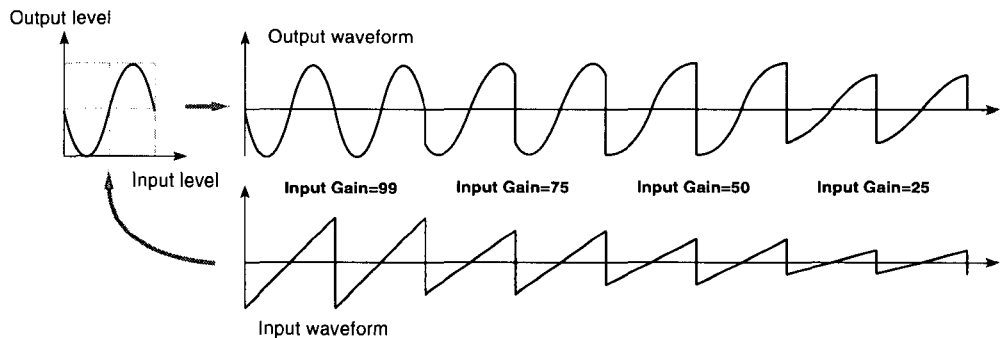

WS1-2 [Input Offset]

This parameter lets you specify an offset value that will be added to the level of the signal that is input from Input Gain.

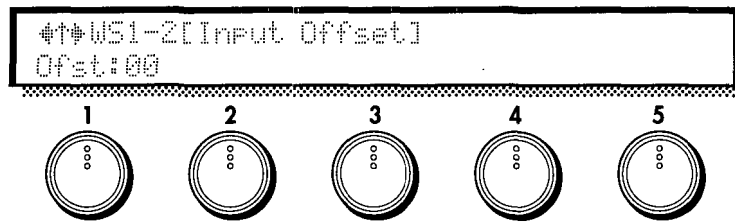

1 Input Offset

[-99...+99]

Specify the offset amount that will added to the signal specified by Input Gain (page WS1-1,1).

An example of changing the Offset (Table Type: Clip)

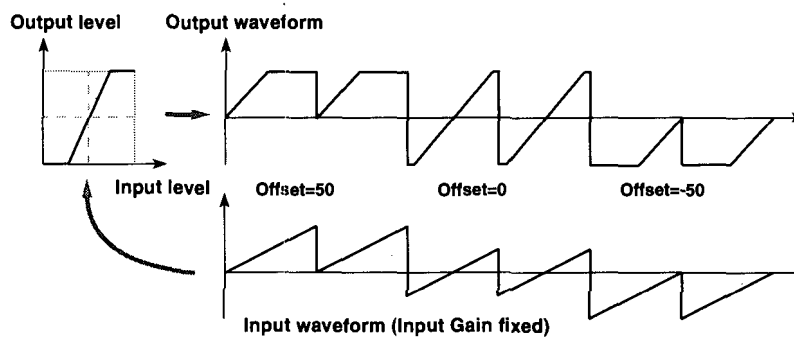

By using Input Gain to reduce the input signal level and adding an Input Offset, you can bias the wave shaping table.

WS1-3 [Feedback & Cross Loop]

These parameters determine the amount of the wave shaping 1 output that is fed back, and the amount of the wave shaping 2 output that is added to the input of wave shape 1.

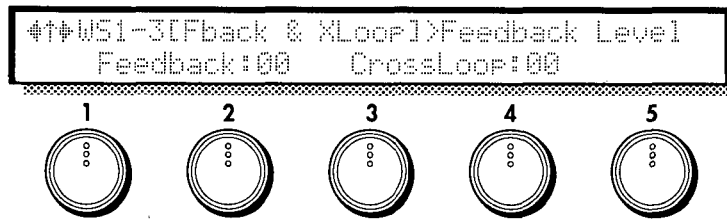

2 Feedback Level

[0...99]

Set the amount of waveshape 1 output that is fed back.

4 Cross Loop Level

[0...99]

Set the amount of the wave shape 2 output that is added to the input of wave shape 1.



Some settings of Feedback Level and Cross Loop Level may produce distorted sound or no sound at all. In such cases, reduce the levels.

WS1-4 [Wave Shape]

Select the wave shaping table that will modify the input waveform, and specify a modulation source that will control the characteristics of the table.

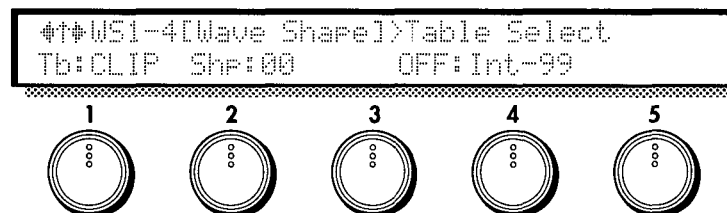

1 Table Select

(Shape Table Type)

[CLIP, RESO]

Select the wave shaping table that will modify the input waveform. The two table types CLIP (Clip type) and RESO (Resonant type) will produce the effects shown in the diagrams below.

•PE171 : WS1 •PE178 : WS2

2 Shape

[0...99]

Set the characteristics of the table that modifies the input waveform. The diagrams below show how this parameter modifies the table.

•PE172 : WS1 •PE179 : WS2

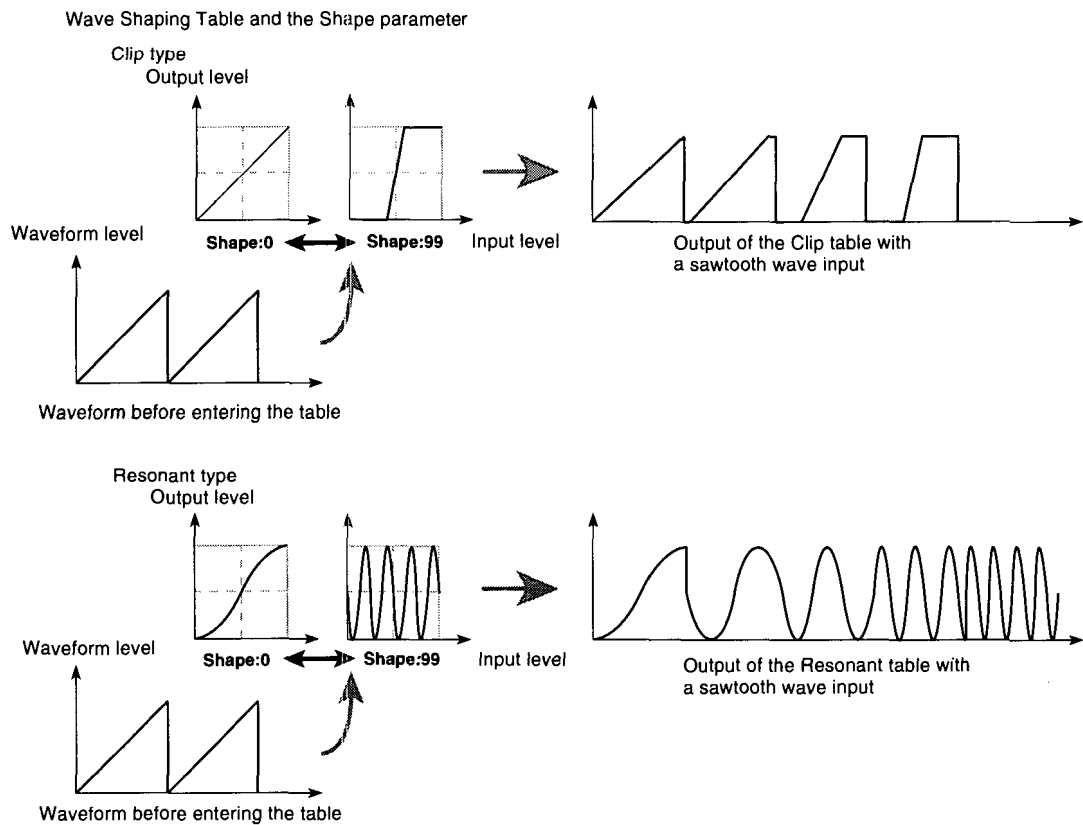

3 Mod.Source (Shape Modulation Source)

[OFF...CChg#95]

Select the modulation source that will control Shape. (Refer to 6.3 Modulation Source List.)

4 Mod.Intensity (Shape Mod.Intensity)

[-99...+99]

Set the depth and direction in which the selected Shape Modulation Source will affect the Shape. With positive (+) settings, higher values of the modulation source will increase the Shape value. With negative (-) settings, lower values of the modulation source will increase the Shape value. If EG or LFO has been selected as the Shape Modulation Source, positive (+) settings will cause the original phase of the EG or LFO to be used, and negative (-) settings will invert the phase.

•PE173 : WS1 •PE180 : WS2

WS1-5 [Output]

These parameters adjust the output levels of the sound that passes through Wave Shaping 1 and the direct sound from OSC1.

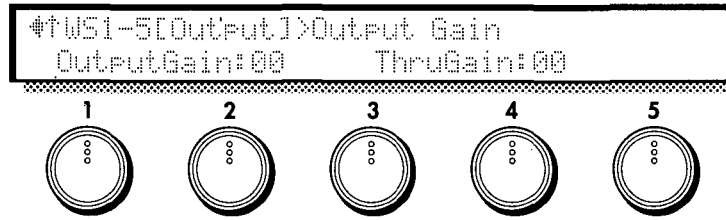

2 Output Gain [0...99]

Set the level of the output signal from Wave Shaping 1.

•PE174 : WS1 •PE181 : WS2

4 ThruGain (Thru Gain) [0...99]

Set the level of the direct signal from OSC1.

•PE175 : WS1 •PE182 : WS2

An example of using Thru Gain / Output Gain (Table Type: Reso)

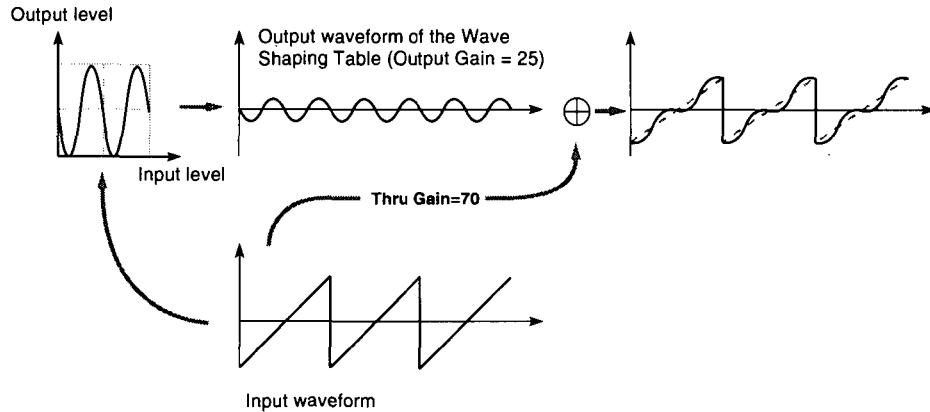

[WS2]

WS2-1 [Input Gain]...WS2-5 [Output]

The [WS2] parameters are the same as the [WS1] parameters. [WS1-1...5]. Refer to the above sections WS1-1...1-5.

[UTY] - Utility

WSU-1 [Initialize]

This utility command initializes the wave shaping table.

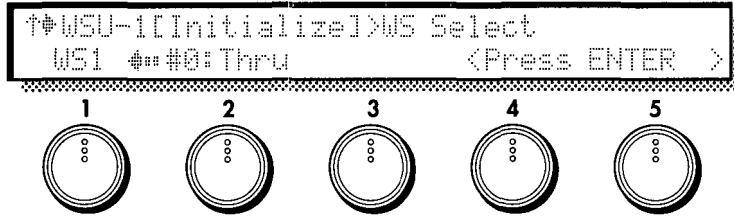

1 **WS Select** (Wave Shape Select) [WS1, WS2, ALL]

Select the wave shape that you wish to initialize.

2 **Initial Type** [#0...5]

Select one of the following 6 recommended settings.

- | | |
|-----------------|---------------------------------------|
| #0:Thru | There will be no wave shaping effect. |
| #1:Booster | The signal will be boosted. |
| #2:SoftClip | The signal will be lightly clipped. |
| #3:HardClip | The signal will be heavily clipped. |
| #4:SoftResonant | Light resonance will be applied. |
| #5:HardResonant | Heavy resonance will be applied. |

Make the desired selection, and press the ENTER key to execute.

WSU-2 [Copy]

This utility command copies the wave shaping parameters of another program to the currently selected program.

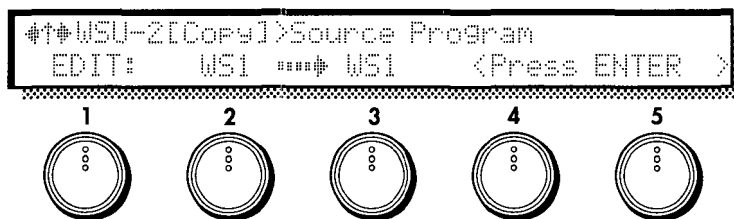

1 **Source Program** [EDIT, A00...C63]

Select the copy source program.

If you have selected C00~C63 and if no card is inserted, the display will indicate <No Card>, and the operation will be halted. If an unformatted card is inserted, the display will indicate <Illegal Format>, and the operation will be halted.

2 Source WS (Source Wave Shape)

[WS1, WS2, ALL]

Select the copy source wave shape. If ALL is selected, the following Destination setting will be ignored.

3 Destination

[WS1, WS2]

Select the copy destination (current) wave shape.

Make the desired selection, and press the ENTER key to execute.

! If the Source Program is EDIT and if the Source WS and the Destination are the same, the display will indicate <Ignore > and the operation will be halted.

WSU-3 [Swap]

This utility command exchanges the settings of wave shape 1 and 2 within the same program.

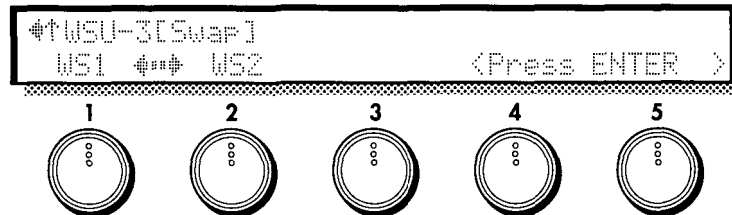

Press the ENTER key to execute.

4-3. Mixer Section

The mixer section allows you to set the levels at which the five signals (WS1 Out, WS2 Out, Noise Generator, Feedback, Sub OSC) will be combined into the two mixer outputs. You can also select a modulation source to control each level, and specify its intensity.

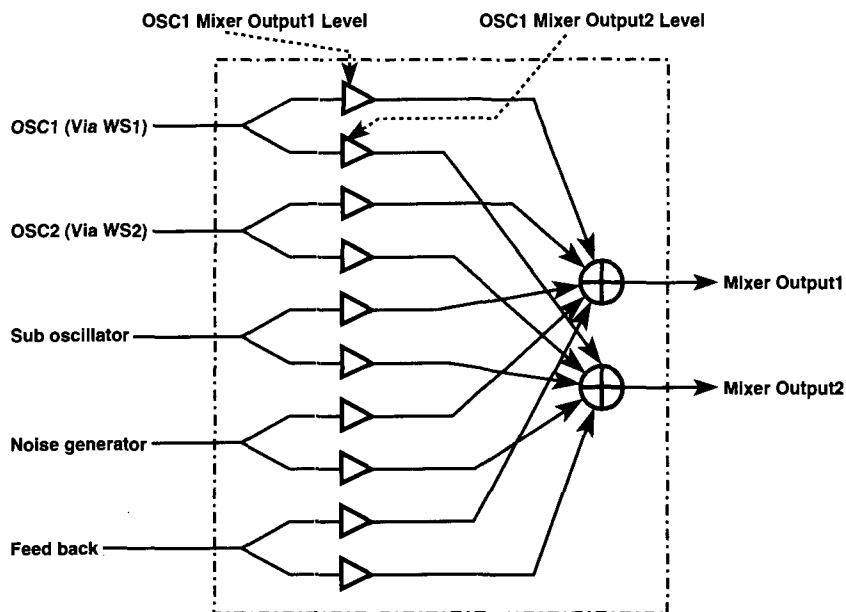

MIX-1 [OSC1 → OUT1]

These parameters adjust the level at which the oscillator 1 signal passing through wave shaping 1 is output from mixer output 1, and specify a modulation source that will control this level.

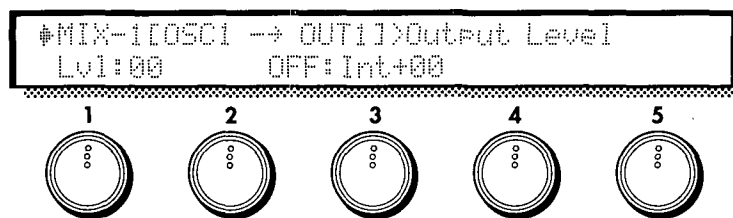

1 Output Level

[0...99]

Set the level that will be output to mixer output 1.

•PE149

2 Level Mod.Source (Level Modulation Source)

[OFF...CChg#95]

Select a modulation source that will control the above output level. (Refer to 6.3 Modulation Source List.)

Set the depth and direction in which the selected Level Modulation Source will affect the level. With positive (+) settings, higher values of the modulation source will increase the level. With negative (-) settings, lower values of the modulation source will increase the level. If EG or LFO has been selected as the Level Modulation Source, positive (+) settings will cause the original phase of the EG or LFO to be used, and negative (-) settings will invert the phase.

•PE150

MIX-2 [OSC1 → OUT2]

These parameters adjust the level at which the oscillator 1 signal passing through wave shaping 1 is output from mixer output 2, and specify a modulation source that will control this level.

Refer to the above explanation of MIX-1 [OSC1 → OUT1]

•PE151: Level •PE152: Level Mod. Intensity

MIX-3 [OSC2 → OUT1]

These parameters adjust the level at which the oscillator 2 signal passing through wave shaping 2 is output from mixer output 1, and specify a modulation source that will control this level.

Refer to the above explanation of MIX-1 [OSC1 → OUT1].

•PE153: Level •PE154: Level Mod. Intensity

MIX-4 [OSC2 → OUT2]

These parameters adjust the level at which the oscillator 2 signal passing through wave shaping 2 is output from mixer output 2, and specify a modulation source that will control this level.

Refer to the above explanation of MIX-1 [OSC1 → OUT1].

•PE155: Level •PE156: Level Mod. Intensity

MIX-5 [SUBOSC → OUT1]

These parameters adjust the level at which the sub oscillator signal output is output from mixer output 1, and specify a modulation source that will control this level.

Refer to the above explanation of MIX-1 [OSC1 → OUT1].

•PE157: Level •PE158: Level Mod. Intensity

MIX-6 [SUBOSC → OUT2]

These parameters adjust the level at which the sub oscillator signal output is output from mixer output 2, and specify a modulation source that will control this level.

Refer to the above explanation of MIX-1 [OSC1 → OUT1].

•PE159: Level •PE160: Level Mod. Intensity

MIX-7 [NOISE → OUT1]

These parameters adjust the level at which the output of the noise generator is output from mixer output 1, and specify a modulation source that will control this level.

Refer to the above explanation of MIX-1 [OSC1 → OUT1].

•PE161: Level •PE162: Level Mod. Intensity

MIX-8 [NOISE → OUT2]

These parameters adjust the level at which the output of the noise generator is output from mixer output 2, and specify a modulation source that will control this level.

Refer to the above explanation of MIX-1 [OSC1 → OUT1].

•PE163: Level •PE164: Level Mod. Intensity

MIX-9 [Feedback → OUT1]

These parameters adjust the level at which the feedback from the amp section is output from mixer output 1, and specify a modulation source that will control this level.

Refer to the above explanation of MIX-1 [OSC1 → OUT1].

•PE165: Level •PE166: Level Mod. Intensity

MIX-10 [Feedback → OUT2]

These parameters adjust the level at which the feedback from the amp section is output from mixer output 2, and specify a modulation source that will control this level.

Refer to the above explanation of MIX-1 [OSC1 → OUT1].

•PE167: Level •PE168: Level Mod. Intensity



Raising the Feedback level excessively may cause the sound to distort.

4-4. Filter Section

The Prophecy contains two multi-mode filters. For each one, you can select one of four filter types; LPF, HPF, BPF, and BRF.

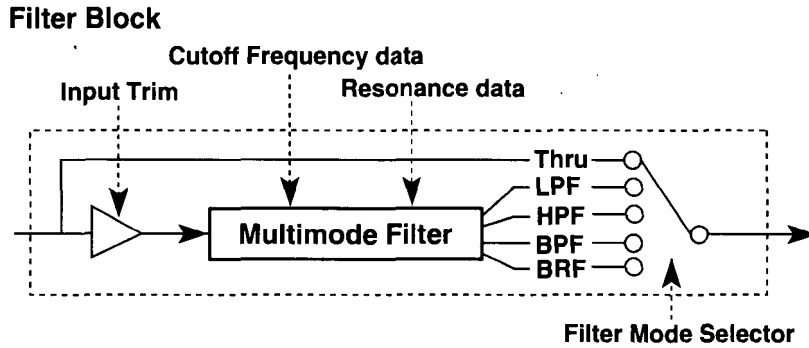

FLT-1 [Filter Menu]

Here you can select the routing type and access the items of the filter menu.

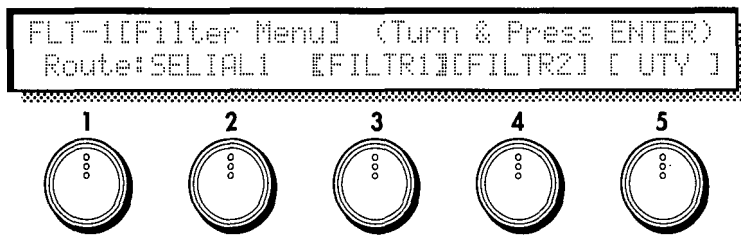

2 Routing (Filter Routing) [SERIAL1, SERIAL2, PARALLEL]

Select one of three types of routing to specify how the output from the mixer will be pass through the filters to the amplitude blocks.

Serial1

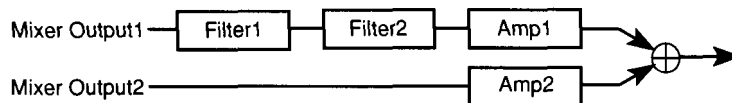

Serial2

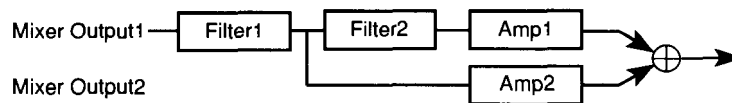

Parallel

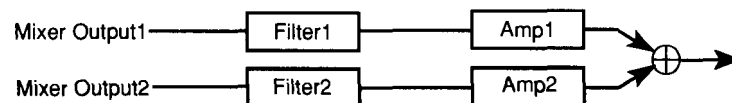

If you wish to use band pass filters to create two peaks in the frequency response, select PARALLEL. If you wish to use band reject filters to create two valleys in the frequency response, select SERIAL. In this case, setting filters 1 and 2 to the same settings will sharpen the slope of the cutoff.

3 [FILTR1] (Filter1)

4 [FILTR2] (Filter2)

5 [UTY] (Utility)

3, 4, and 5 are menu items. Select filter 1 or 2 for editing, or select the utility commands. [FILTR1] and [FILTR2] are the settings for the two filters. [UTY] allows you to initialize or copy filter settings. Use the CURSOR keys or the knobs to select the desired item, and press the ENTER key to enter the selected page.

The parameters of [FILTR2] are organized in the same way as those of FILTR1. Refer to the explanations for page FL1-1...5.

FL1-1 [Type & Input]

These parameters specify the filter type for filter 1, and set the level of the signal input from the mixer.

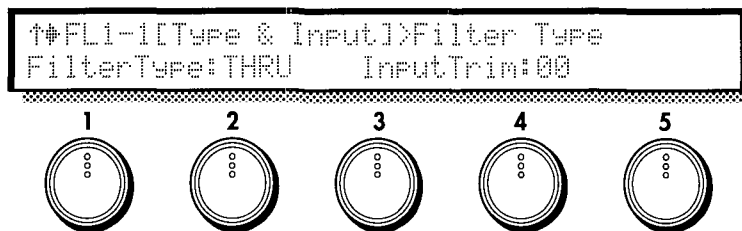

2 Filter Type

[THRU, LPF, HPF, BPF, BRF]

Select the filter type for filter 1.

How Filter Type is related to Cutoff Frequency

With a setting of THRU, the filter will not apply.

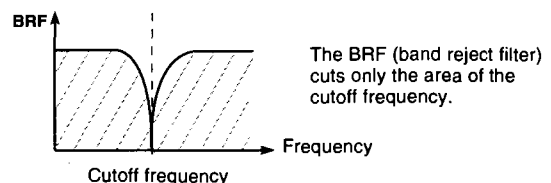
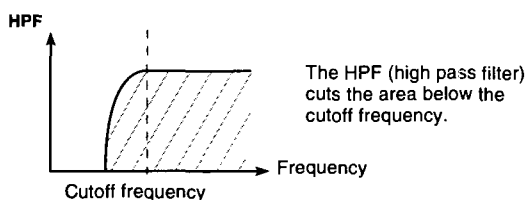
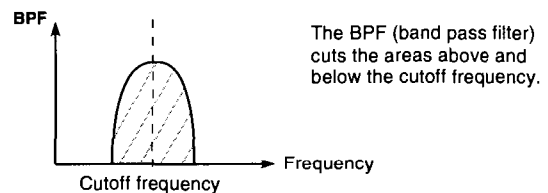
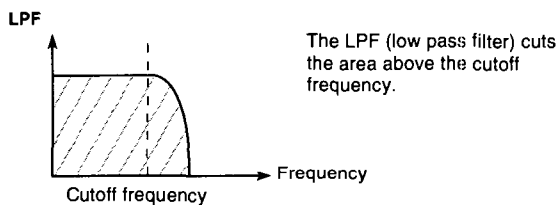

4 Input Trim

[00...99]

Adjust the level that is input to filter 1.



If this setting is increased, distortion may occur if the Resonance setting is high. To adjust the volume, make settings in the AMP section page AMP1-1 and AMP2-1 AMPLITUDE.

FL1-2 [Cutoff]

These parameters determine the cutoff frequency for filter 1, and how an EG will affect the cutoff frequency over time, etc.

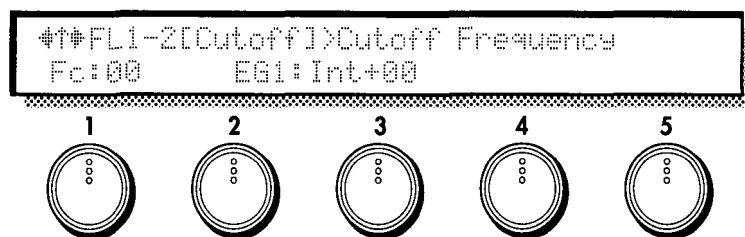

1 Cutoff Frequency

[00...99]

Set the cutoff frequency for filter 1. Increasing this value will raise the cutoff frequency.

•PE28 : FL1 •PE34 : FL2

2 Mod.EG

(Cutoff Frequency Modulation EG)

[EG1...EG4, P.EG, A.EG]

Specify the EG that will create time-varying change in the cutoff frequency of filter 1. For the settings of each EG, refer to p.111 for EG1~4, p.13 for the P.EG, and p.84 for the A.EG.

3 Mod.EG Intensity (Cutoff Frequency Mod. EG Int.)

[-99...+99]

Specify the depth and direction in which the Cutoff Frequency Modulation EG will affect the cutoff frequency. With positive (+) settings, the EG will move the Cutoff Frequency upward. (When the various EG levels are 0, the cutoff frequency will be at the value specified by the setting of the Cutoff Frequency parameter.) The sound will become brighter for positive (+) EG levels, and darker (more muted) for negative (-) EG levels.

Setting negative (-) values for this Mod.EG Intensity parameter will have the opposite effect of positive (+) settings.

•PE29 : FL1 •PE35 : FL2

FL1-3 [Resonance]

These parameters set the resonance of filter 1, and specify a modulation source which will control the resonance.

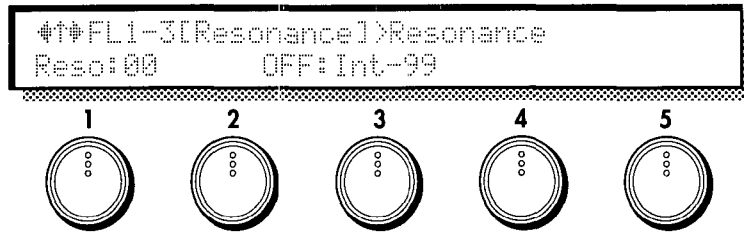

1 Resonance

[0...99]

Specify the degree to which the frequencies in the region of the Cutoff Frequency (page FL1-2,1) will be emphasized. Higher values will produce a stronger effect. High settings of Resonance may cause the output signal of the filter to be distorted. In such cases, lower the Input Trim (FL1-1,4) setting.

•PE32 : FL1 •PE38 : FL2

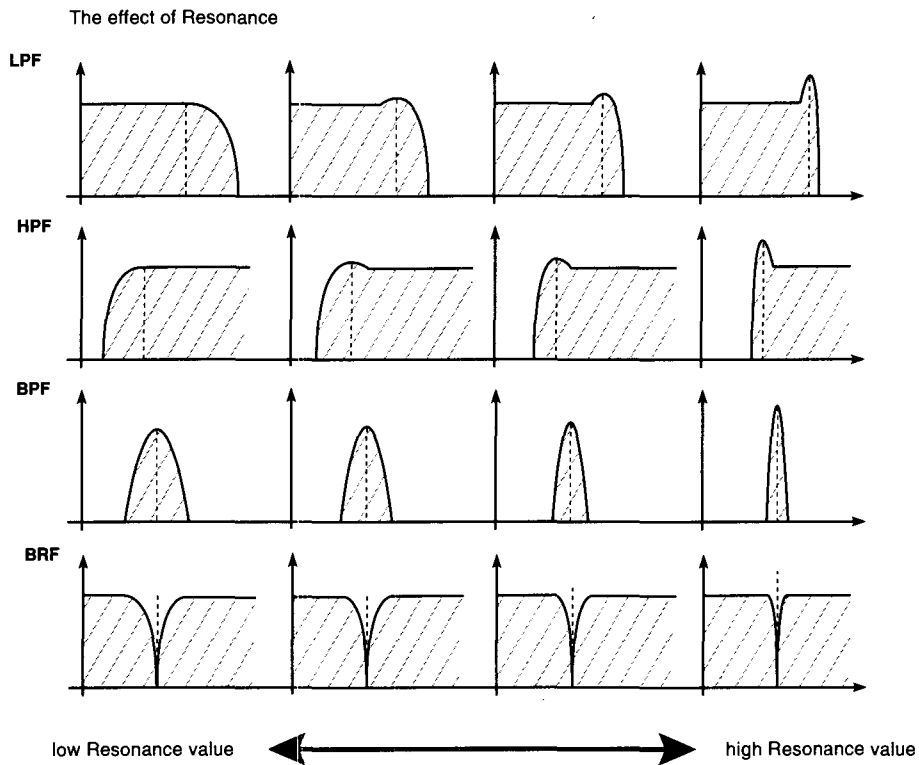

2 Mod.Source

(Resonance Modulation Source)

[OFF...CChg#95]

Select the modulation source that will control Resonance. (Refer to 6.3 Modulation Source List.)

3 Mod.Intensity

(Resonance Mod. Intensity)

[-99...+99]

Specify the amount and direction by which the selected Resonance Modulation Source will affect the Resonance. With positive (+) settings the Resonance will be raised, and with negative (-) settings it will be lowered. If EG or LFO is selected as the Resonance Modulation Source, they will take effect with their original phase for positive (+) settings, and with inverted phase for negative (-) settings.

•PE33 : FL1 •PE39 : FL2

FL1-4 [Fc Kbd Trk] Cutoff Frequency Keyboard Track

These parameters specify how keyboard tracking will affect the cutoff frequency of filter 1.

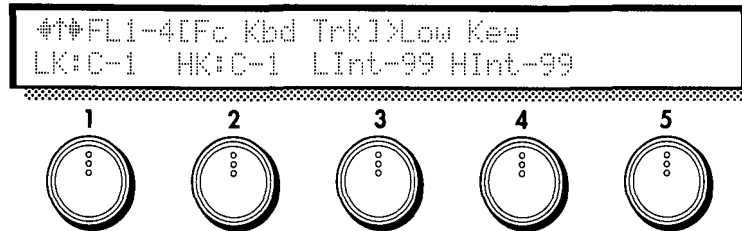

1 Low Key [C-1...G9]

Specify the key at which Lower keyboard tracking will begin.

2 High Key [C-1...G9]

Specify the key at which Higher keyboard tracking will begin.

3 Lower Intensity [-99...+99]

Specify the depth and direction with which key position below the Low Key will affect the Cutoff Frequency. With a setting of -50, the change in Cutoff Frequency will be the same as the change in pitch.

4 Higher Intensity [-99...+99]

Specify the depth and direction with which key position above the High Key will affect the Cutoff Frequency. With a setting of -50, the change in Cutoff Frequency will be the same as the change in pitch.

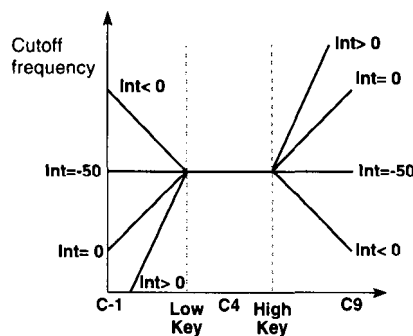

With positive (+) settings, the sound will become brighter as you play further beyond the Low Key or High Key. Negative (-) settings will have the opposite effect. With a setting of 0, the cutoff frequency will remain the same regardless of the position of the note you play. The cutoff frequency value in the area between Low Key and High Key is fixed.

FL1-5 [Fc Modulation]

These parameters select the LFO that will control the cutoff frequency of filter 1, and specify a modulation source that will control it.

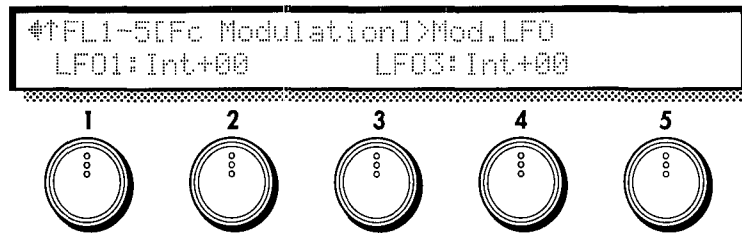

1 **Mod.LFO** (Cutoff Frequency Modulation LFO) [LFO1...4]

Select the LFO that will control the cutoff frequency of filter 1. Settings for each LFO are made in the LFO section.

2 **Mod.LFO Int** (Cutoff Frequency Mod. LFO Int.) [-99...+99]

Specify the depth and direction in which the Cutoff Frequency Modulation LFO will affect the cutoff frequency. With positive (+) settings the original phase of the LFO will be used. Negative (-) settings will invert the phase of the LFO.

•PE30 : FL1 •PE36 : FL2

3 **Mod.Source** (Cutoff Frequency Modulation Source) [OFF...CChg#95]

Select the modulation source that will control cutoff frequency. (Refer to 6.3 Modulation Source List.)

4 **Mod.Intensity** (Cutoff Frequency Mod. Intensity) [-99...+99]

Specify the depth and direction in which the Cutoff Modulation Source will affect the cutoff frequency. With positive (+) settings the cutoff frequency will be raised, and with negative (-) settings it will be lowered. If EG is specified as the Cutoff Frequency Modulation Source, it will take effect with its original phase for positive (+) settings, and with inverted phase for negative (-) settings. Setting Cutoff Frequency Modulation Source to LFO will have the same effect as Cutoff Frequency Modulation LFO.

•PE31 : FL1 •PE37 : FL2

FL2-1 [Type & Input]...FL2-5 [Fc Modulation]

These are the parameters for Filter 2. The parameter structure for filter 2 is identical to filter 1. Refer to the preceding explanations for [FL1-1...5].

[UTY] - Utility

FLU-1 [Initialize]

This utility command initializes a filter.

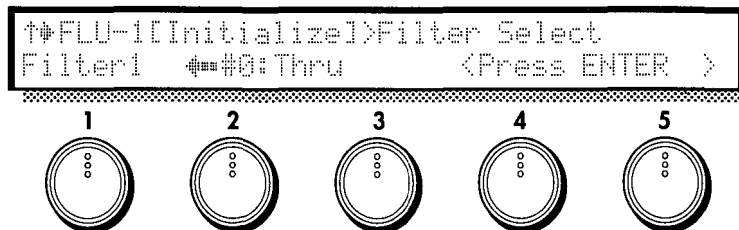

1 Filter Select

[Filter1, Filter2, Filter1&2]

Select the filter that will be initialized.

2 Initial Type

[#0...4]/[#0...3]

The filter selected by Filter Select will be initialized to one of the following standard settings.

If Filter Select is Filter 1 or Filter 2:

#0: Thru	The filter will not be used.
#1: LowPass	Standard low pass filter settings.
#2: HighPass	Standard high pass filter settings.
#3: BandPass	Standard band pass filter settings.
#4: BPF_Note	Band pass filter settings where the center frequency will track the pitch.

If Filter Select is Filter 1&2:

#0: SaxBody	The filter will accentuate the characteristics of the Reed OSC.
#1: Formant	The filter will produce human voice-like tonality.
#2: Trumpet	The filter will accentuate the characteristics of the Brass OSC.
#3: MuteTrumpet	The filter will create the tone characteristic of a brass instrument with a mute inserted.

FLU-2 [Copy]

This utility command copies filter settings from another program into the currently-selected program.

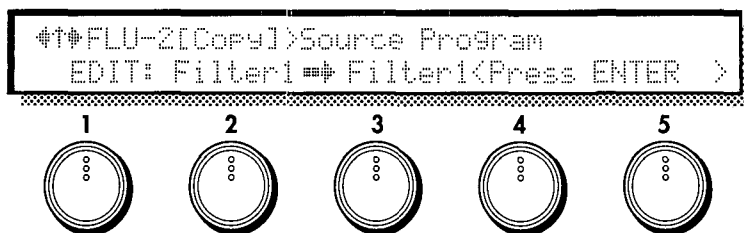

1 Source Program [EDIT, A00...C63]

Select the copy source program. If you select EDIT, the program currently being edited (i.e., the program in current memory) will be selected.

If you have selected C00~C63 and if no card is inserted, the display will indicate <No Card>, and the operation will be halted. If an unformatted card is inserted, the display will indicate <Illegal Format>, and the operation will be halted.

2 Source Filter [Filter1, Filter2, ALL]

Select the copy source filter. If ALL is selected, the following Destination parameter will be ignored.

3 Destination [Filter1, Filter2]

Select the copy destination filter.

Make selections, and press the ENTER key to execute.



If the Source Program is EDIT and the Source Filter and Destination are the same, the display will indicate <Ignore > and the operation will be halted.

FLU-3 [Swap]

This utility command exchanges the filter 1 and 2 settings.

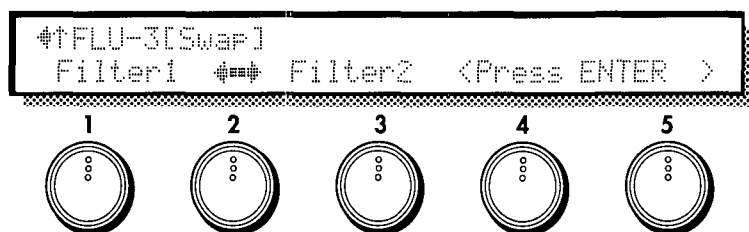

Press the ENTER key to execute.

4-5. Amplifier Section

The amplifier (AMP) section contains the volume-related settings.

There are two independent amplifiers, the signals which are input into the AMP section will depend on the Filter Routing (page FLT-1,2).

AMP-1 [Amp Menu]

This is the Amp Menu page.

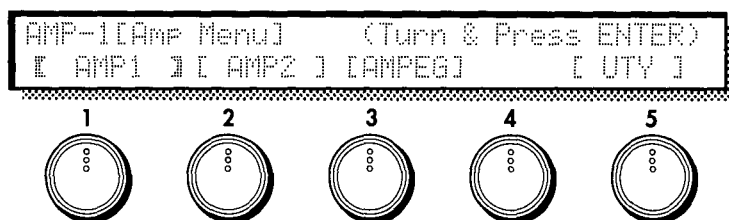

1 [AMP1] (Amplitude 1)

2 [AMP2] (Amplitude 2)

3 [AMPEG] (Amplitude EG)

5 [UTY] (Utility)

Select the AMP or EG to edit, or the utility page.

[AMP1] and [AMP2] make volume settings, and [AMPEG] determines how volume will change over time. [UTY] allows you to initialize or copy amp-related settings.

Use the CURSOR keys or the knobs to select the item that you wish to edit, and press the ENTER key to enter the item.

The parameter structure of [AMP2] is the same as [AMP1]. Refer to the explanation of AMP1-1...2.

[AMP1]

AMP1-1 [Amplitude] - Amplitude 1

These parameters set the volume level of Amplitude 1, and specify the depth and direction by which volume levels will be adjusted by keyboard tracking.

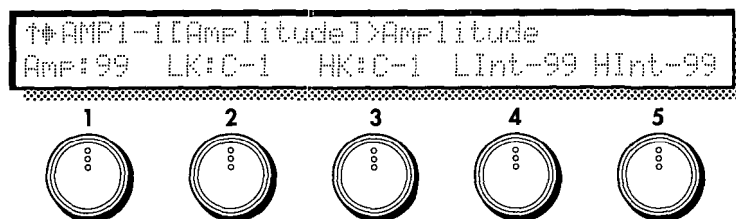

1 Amplitude [0...99]

Set the input levels of amp 1 from filter 1 and 2 (refer to page FLT-1,2). Higher values will produce a higher volume level.

•PE40 : AMP1 •PE42 : AMP2

2 Kbd Trk Low Key (Keyboard Tracking Low Key) [C-1...G9]

Specify the key at which Lower keyboard tracking will begin.

3 Kbd Trk High Key (Keyboard Tracking High Key) [C-1...G9]

Specify the key at which Higher keyboard tracking will begin.

4 Kbd Trk Lower Int (Keyboard Tracking Lower Intensity) [-99...+99]

Specify the depth and direction at which the volume level will be adjusted for notes lower than the Low key.

5 Kbd Trk Higher Int (Keyboard Tracking Higher Intensity) [-99...+99]

Specify the depth and direction at which the volume level will be adjusted for notes above the High key.

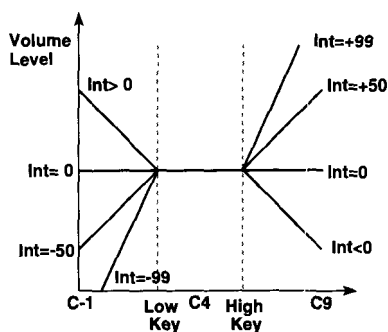

With positive (+) settings, the volume will be progressively increased for notes further away from the Keyboard Tracking Low/High Key. With negative (-) settings the opposite will occur. With a setting of 0, the volume will be constant regardless of the position of the note. Notes between the Low Key and High Key will sound at the same volume.

AMP1-2 [Amp Modulation]

These parameters specify how a selected EG and modulation source will control amp 1.

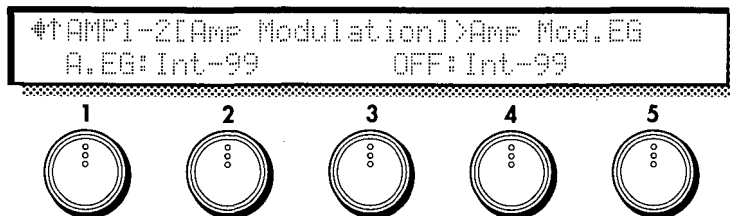

1 Amp Mod. EG (Amplitude Modulation EG) [EG1...EG4, P.EG, A.EG]

Select the EG that will apply time-variant changes to the Amplitude 1 volume level. For the settings of each EG, refer to p.111 for EG1~4, p.13 for the P.EG, and p.84 for the A.EG.

2 Mod. EG Int (Amplitude Mod. EG Intensity) [-99...+99]

Specify the depth and direction of the effect that the selected Amplitude Modulation EG will have on the volume.

3 Mod. Source (Amplitude Modulation Source) [OFF...CChg#95]

Select a modulation source that will control the volume level of Amplitude 1. (Refer to 6.3 Modulation Source List.)

4 Mod. Intensity (Amplitude Mod. Intensity) [-99...+99]

Specify the depth and direction of the effect that the Amplitude Modulation Source will have on the volume. If you have selected EG or LFO as the Amplitude Modulation Source, positive (+) values will use the original phase, and negative (-) values will invert the phase of the EG or LFO.

•PE41 : AMP1 •PE43 : AMP2

[AMP2]

AMP2-1 [Amplitude]...AMP2-2 [Amp Modulation]

These parameters are the settings for Amplitude 2. Amp 2 has the same parameter structure as amp 1. Refer to the preceding sections AMP1-1...2..

[AMP EG]

Here you can make settings for the Amp EG. The Amp EG determines how the volume will change over time.

On the Prophecy, the Amp EG can be used as a general-purpose controller, so that it can control time-varying changes for other parameters in addition to volume.

To create change in volume over time using the Amp EG, select A.EG for the Amplitude Modulation EG parameter (AMP1-2,1/AMP2-2,1), and set the Amplitude Mod.EG Intensity parameter (AMP1-2,2/AMP2-2,2) to specify the depth of the effect.

You can have additional control over volume by selecting an Amplitude Modulation Source (AMP1-2,3/AMP2-2,3) and setting the Amplitude Mod.Intensity.

AEG-1 [Amp EG Level]

These parameters specify the levels to which the volume will change in response to your pressing and releasing a note.

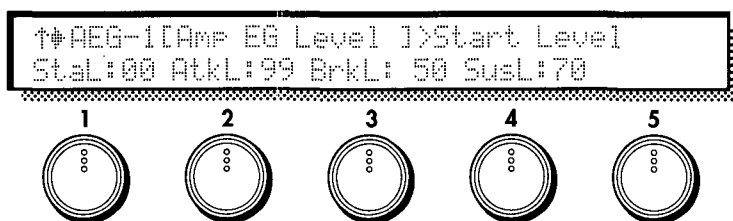

How Amp EG creates time-varying changes in volume

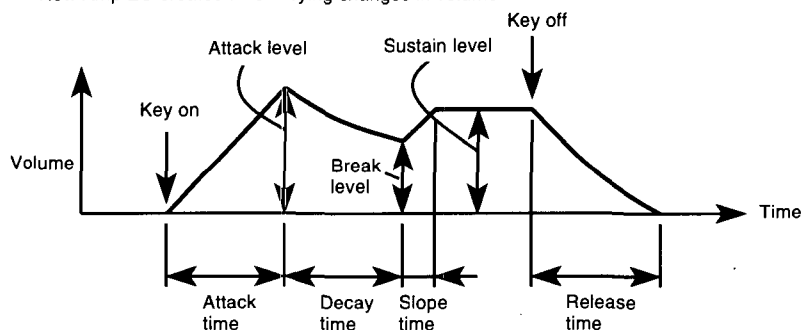

1 Start Level [0...99]

Set the volume level at key-on (when the note is pressed).

•PE44

2 Attack Level [0...99]

Set the volume level reached after the Attack Time.

•PE46

3 Break Level [0...99]

Set the volume level reached after the Decay Time.

•PE48

4 Sustain Level [0...99]

Set the volume level reached after the Slope Time.

•PE50

AEG-2 [Amp EG Time]

These parameters determine the times over which the volume will change in response to your pressing and releasing a note.

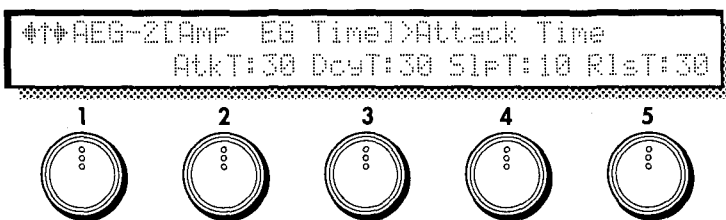

2 Attack Time [0...99]

Set the time over which the volume will change from key-on (when you press the key) until it reaches the Attack Level. With a setting of 0, the volume will change instantly. With a setting of 99 it will change slowly.

•PE45

3 Decay Time [0...99]

Set the time over which the volume will change from after the Attack Time ends until the Break Point is reached. For details, refer to the preceding explanation of Attack Time.

•PE47

4 Slope Time [0...99]

Set the time over which the volume will change from after the Decay Time ends until the Sustain Level is reached. For details, refer to the preceding explanation of Attack Time.

•PE49

5 Release Time [0...99]

Set the time over which the volume will fall to zero after key-off (when you release the key). For details, refer to the preceding explanation of Attack Time.

•PE51

AEG-3 [Amp EG KbdTrk] Amplitude EG Keyboard Tracking

These parameters specify how keyboard position will affect the times of the Amplitude EG.

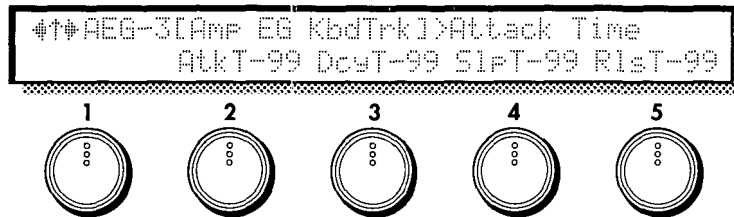

2 Attack Time [-99...+99]

3 Decay Time [-99...+99]

4 Slope Time [-99...+99]

5 Release Time [-99...+99]

Specify the depth and direction at which each EG time (page AEG-2) will be affected by keyboard position. With positive (+) settings, EG times will become longer as you play higher on the keyboard. With negative (-) settings, EG times will become shorter.

For negative (-) settings of the Time values:

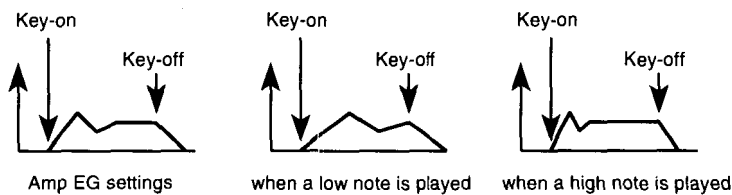

AEG-4 [Amp EG Velocity] Amplitude EG Velocity Control

These parameters specify how keyboard playing dynamics (velocity) will affect the levels and times of the Amplitude EG.

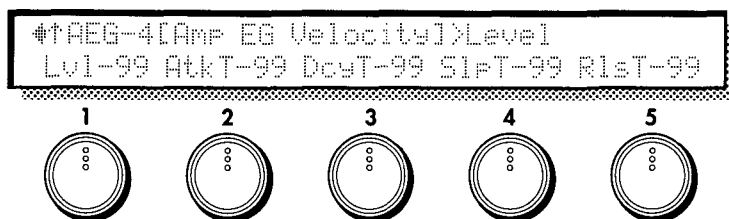

1 Level [-99...+99]

Specify the direction and amount by which velocity will affect EG levels.

With positive (+) settings, Amp EG levels will be increased as you play more strongly. With negative (-) settings, Amp EG levels will be decreased as you play more strongly.

•PE52

For positive (+) Level settings:

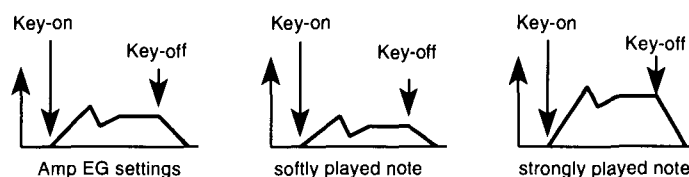

2 Attack Time [-99...+99]

•PE53

3 Decay Time [-99...+99]

•PE54

4 Slope Time [-99...+99]

•PE55

5 Release Time [-99...+99]

•PE56

Specify the direction and amount by which velocity will affect EG times.

With positive (+) settings, Amp EG times will be lengthened for strongly played notes. With negative (-) settings, Amp EG times will be shortened for strongly played notes.

For negative (-) settings of the Time parameters:

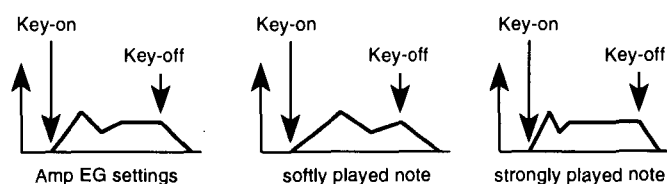

[UTY] - Utility

AMPU-1 [Amp Copy]

This utility command copies amplitude settings from a different program into the currently selected program.

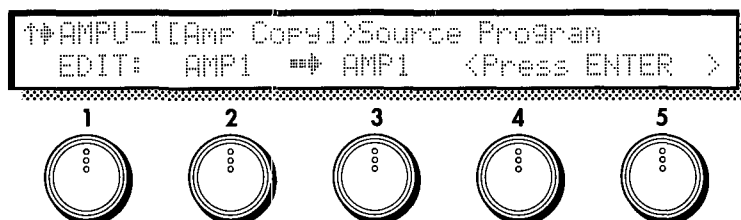

1 Source Program [EDIT, A00...C63]

Select the copy source program. If you select EDIT, the program currently being edited (the program in current memory) will be selected. If you have selected C00~C63 and if no card is inserted, the display will indicate <No Card>, and the operation will be halted.

If an unformatted card is inserted, the display will indicate <Illegal Format>, and the operation will be halted.

2 Source Amp [AMP1, AMP2, ALL]

(Source Amplitude)

Select the copy source amplitude. If you select ALL, the following Destination parameter will be ignored.

3 Destination [AMP1, AMP2]

(Target Amplitude)

Select the copy destination amplitude.

Make the desired selections, and press the ENTER key to execute.

! If the Source Program is EDIT, and the same amp is selected for both Source Amp and Destination, the display will indicate <Ignore > and the operation will be halted.

AMPU-2 [Amp Swap]

This utility command exchanges amplitude settings within the same program.

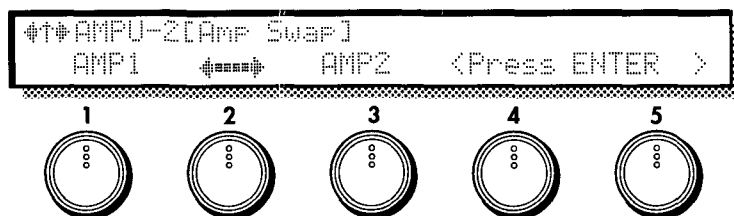

The AMP1 and AMP2 settings will be exchanged.

Press the ENTER key to execute.

4-6. Effect Section

The effect section provides seven types of effect, and two possible routings (ways in which the effects can be connected). The routing is selected by page FX-2 [Delay/Reverb] Delay/Reverb Select.

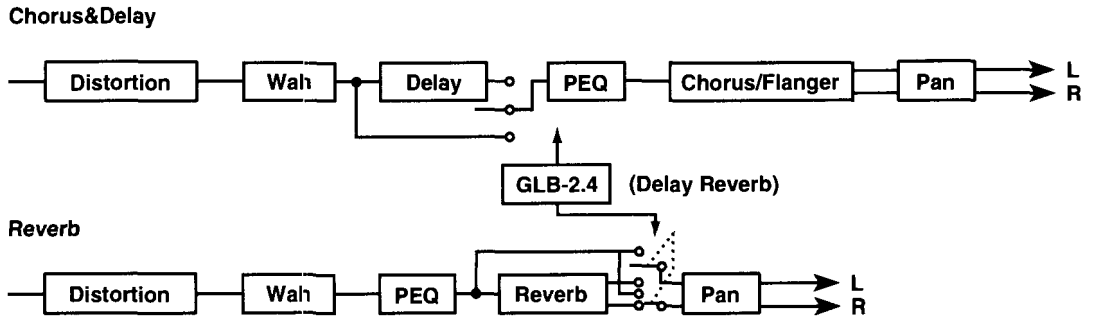

⚠ The GLB-2,4 Delay /Reverb (ON/BYPASS) setting allows you to turn on or bypass the delay or reverb module routing.

FX-1 [Distortion & Wah]

This is the Distortion & Wah menu page.

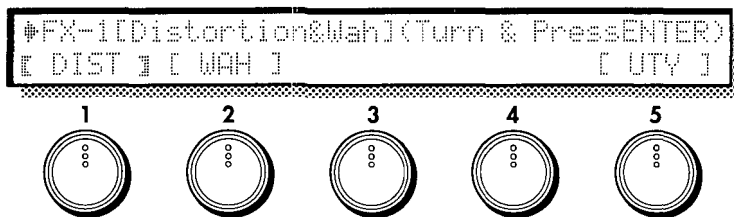

1 [DIST] (Distortion)

2 [WAH] (Wah)

3 [UTY] (Utility)

Select either distortion or wah for editing, or access the utility commands. [DIST] accesses the distortion settings and [WAH] accesses the wah settings. [UTY] allows you to initialize or copy these effects.

Use the CURSOR keys or the knobs to select the item you wish to edit, and press the ENTER key to enter the selected item.

[DIST] - Distortion

This effect distorts the input sound.

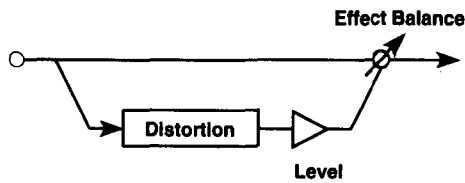

DIST-1 [Distortion] - Distortion

Set the output level and the tone of the distortion.

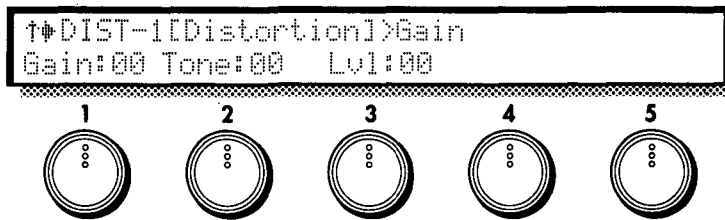

1 Gain [0...99]

Set the degree by which the input sound will be distorted.

•PE57

2 Tone [0...99]

Adjust the tone of the effect sound.

•PE58

3 Fx Level [0...99]

Adjust the output level of the effect sound.

DIST-2 [Fx Balance] - Distortion

These parameters adjust the output balance of the direct and effect sounds, and specify a modulation source that will control this balance.

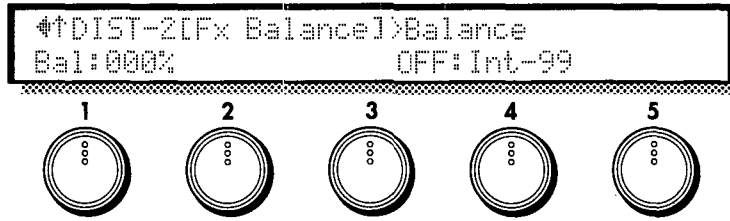

1 Balance (Effect Balance) **[0...100%]**

Set the output balance of the direct sound and effect sound. With a setting of 0 only the direct sound will be output, and with a setting of 100 only the effect sound will be output.

•PE59

3 Bal Mod.Source (Effect Balance Modulation Source) **[OFF...CChg#95]**

Select a modulation source that will control Effect Balance. (Refer to 6.3 Modulation Source List.)

4 Bal Mod.Intensity (Effect Balance Mod. Intensity) **[-99...+99]**

Specify the depth and direction of the selected Effect Balance Modulation Source will have. With positive (+) settings, the Effect Balance value will be raised, and with negative (-) values it will be lowered. If you have selected EG or LFO as the Effect Balance Modulation Source, positive (+) values will use the original phase, and negative (-) values will invert the phase of the EG or LFO.

[WAH] - Wah

This effect modifies the tone by creating an area of frequency emphasis which can be swept up and down.

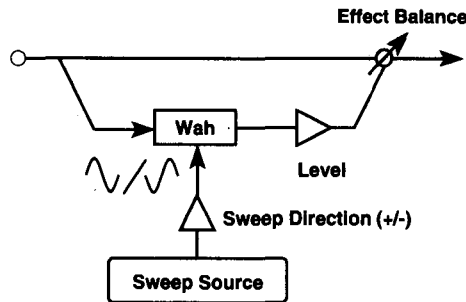

WAH-1 [Level & Resonance] - Wah

These parameters adjust the output level of the wah, and adjust the tone of the effect.

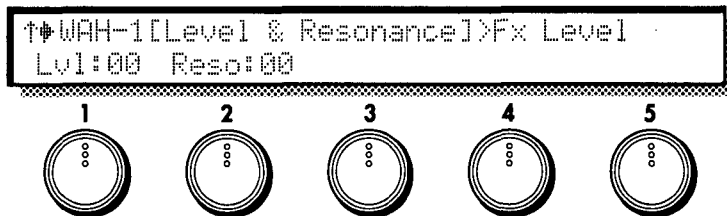

1 Fx Level

[0...99]

Adjust the output level of the wah.

2 Resonance

[0...99]

This parameter determines the character of the sound. Higher settings will produce a stronger wah effect.

•PE60

WAH-2 [Sweep] - Wah

These parameters specify the modulation source that will control the wah filter, and specify the Low/High Frequency settings.

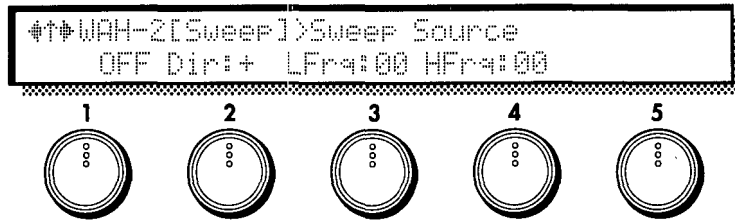

1 Sweep Source [OFF...CChg#95]

Select the modulation source that will control the wah filter. (Refer to 6.3 Modulation Source List.)

2 Sweep Direction [+, -]

Specify the direction of the modulation source selected in Sweep Source. When this parameter is set to "+" the normal phase of the LFO will be used. A setting of "-" will invert the LFO phase.

3 Low Frequency [0...99]

Specify the low limit frequency limit of the range in which the wah filter will move. As this value is increased the frequency will rise.

4 High Frequency [0...99]

Specify the high limit frequency limit of the range in which the wah filter will move. As this value is increased the frequency will rise.

WAH-3 [Fx Balance] - Wah

These parameters set the output balance of the direct sound and effect sound, and specify a modulation source to control it.

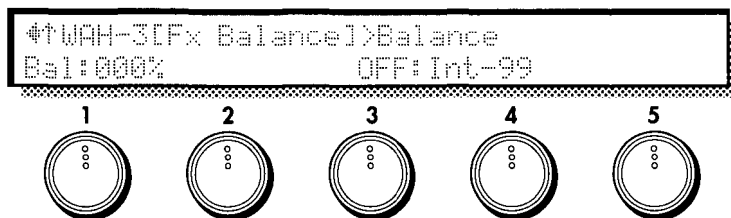

1 Balance (Effect Balance) [0...100%]

Set the output balance of the direct sound and effect sound. With a setting of 0 only the direct sound will be output, and with a setting of 100 only the effect sound will be output.

•PE61

3 Bal Mod.Source (Effect Balance Modulation Source) [OFF...CChg#95]

Select a modulation source that will control Effect Balance. (Refer to 6.3 Modulation Source List.)

4 Bal Mod.Intensity (Effect Balance Mod. Intensity) [-99...+99]

Specify the depth and direction of the control that Effect Balance Modulation Source will have. With positive (+) settings, the Effect Balance value will be raised, and with negative (-) values it will be lowered. If you have selected EG or LFO as the Effect Balance Modulation Source, positive (+) values will use the original phase, and negative (-) values will invert the phase of the EG or LFO.

[UTY] - Utility

DWU-1 [Initialize]

This utility command initializes the distortion or wah parameters of the currently selected program.

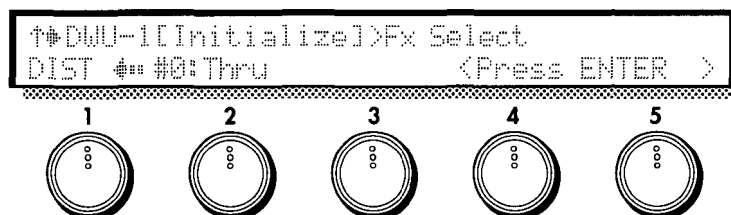

1 Fx Select [DIST, WAH]

Select the effect that you wish to initialize.

2 Initial Type

[#0...2]/[#0...3]

Select one of the following basic settings.

If Fx Select is DIST:

- #0:Thru
- #1:Distortion
- #2:OverDrive

If Fx Select is WAH:

- #0:Thru
- #1:LFO_Wah
- #2:VelocityWah
- #3:RandomWah

Select the desired setting and press the ENTER key to execute.



If you execute #1 and #3 of WAH, the LFO4 setting will be altered.

DWU-2 [Copy]

This utility command copies the distortion or wah settings of another program to the currently selected program.

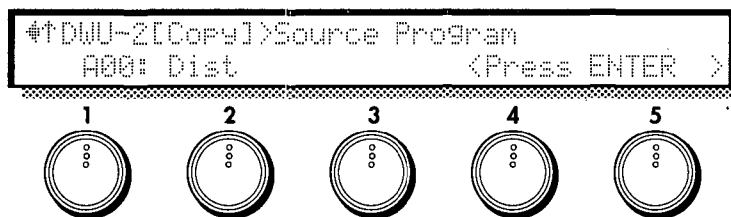

1 Source Program

[A00...C63]

Select the copy source program.

If you have selected C00~C63 and if no card is inserted, the display will indicate <No Card>, and the operation will be halted.

If an unformatted card is inserted, the display will indicate <Illegal Format>, and the operation will be halted.

2 Destination (Target Fx)

[DIST, WAH, DIST&WAH]

Select the effect that you wish to copy.

Select the desired setting and press the ENTER key to execute.

FX-2 [Delay/Reverb]

These parameters select the effect routing type and access the delay/reverb menu items.

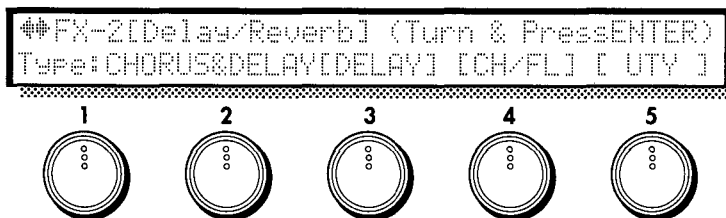

1 **Type** (Delay/Reverb Select) **[CHORUS&DELAY, REVERB]**

Select the effect routing (see p.90).

CHORUS&DELAY : Effect routing 1 will be selected.

REVERB : Effect routing 2 will be selected.

If CHORUS&DELAY is selected for Delay/Reverb Select

3 **[DELAY]** (Delay)

4 **[CH/FL]** (Chorus & Flanger)

5 **[UTY]** (Utility)

Items 3, 4, and 5 are menu items which select delay or chorus/flanger for editing or access the utility commands. [DELAY] accesses the delay settings, [CH/FL] accesses the chorus & flanger settings. [UTY] allows you to initialize or copy effect data.

Use the CURSOR keys or the knobs to select the desired item, and press the ENTER key to enter the selected item.

If REVERB is selected for Delay/Reverb Select

4 **[REVERB]** (Reverb)

5 **[UTY]** (Utility)

Items 4 and 5 are menu items which select reverb parameters for editing or access the utility commands. [REVERB] accesses the reverb settings. [UTY] allows you to initialize or copy reverb settings.

Use the CURSOR keys or the knobs to select the desired item, and press the ENTER key to enter the selected item.

[DELAY] - Delay

* These parameters will appear if CHORUS&DELAY is selected for Delay/Reverb Select (page FX-2,2). This effect adds a time delay to the input signal. The High Damp setting allows you to add a natural-sounding decay to the delay repeats.

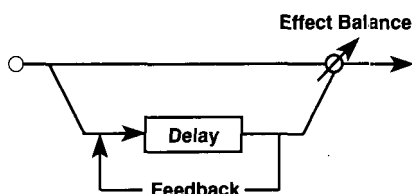

DLY-1 [Delay & Fback] - Delay

Make settings for delay time, feedback, and high damp.

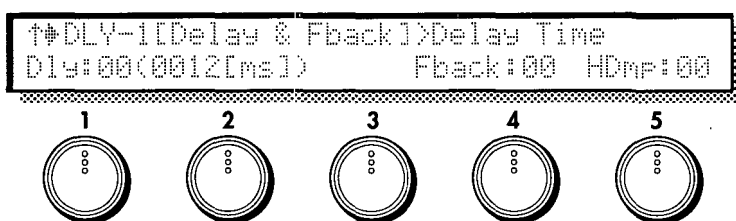

1 Delay Time [0(012[ms])...99(1200[ms])]

Set the Delay Time. The maximum setting (99) produces a delay time of 1.2 seconds.

•PE65

4 Feedback [0...99]

Set the amount of the output signal which is returned (fed back) to the input.

•PE66

5 High Damp [0...99]

Set the amount of attenuation which is applied to the high frequencies of the feedback signal. As this value is increased, the high frequencies will decay faster, producing a darker tone.

•PE67

DLY-2 [Fx Balance] - Delay

These parameters adjust the output balance of the direct sound and effect sound, and specify a modulation source that will control the balance.

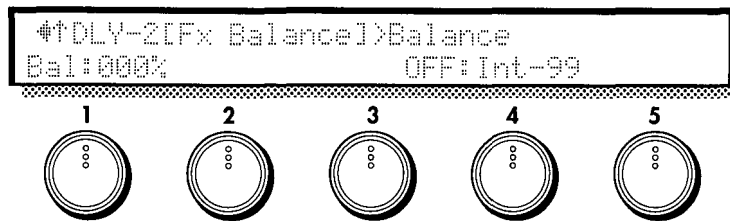

1 **Balance** (Effect Balance) [0...100%]

Set the output balance of the direct sound and effect sound. With a setting of 0 only the direct sound will be output, and with a setting of 100 only the effect sound will be output.

•PE68

3 **Bal Mod.Source** (Effect Balance Modulation Source) [OFF...CChg#95]

Select a modulation source that will control Effect Balance. (Refer to 6.3 Modulation Source List.)

4 **Bal Mod.Intensity** (Effect Balance Mod. Intensity) [-99...+99]

Specify the depth and direction of the control that the selected Effect Balance Modulation Source will have. With positive (+) settings, the Effect Balance will be raised, and with negative (-) values it will be lowered. If you have selected EG or LFO as the Effect Balance Mod.Source, positive (+) values will use the original phase, and negative (-) values will invert the phase of the EG or LFO.

[CH/FL] - Chorus/Flanger

* These parameters will be displayed if CHORUS&DELAY is selected for Delay/Reverb Select (page FX-2,2).

This chorus/flanger effect modulates the delay time of the input signal to add depth and movement to the sound. The effect is mono input and stereo output. The two effect block outputs will be modulated in opposite phase.

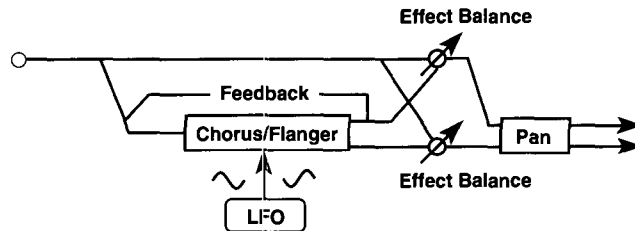

CHFL-1 [Delay & F.Back] - Chorus/Flanger

Adjust the delay time and the amount of the output signal that is fed back to the input.

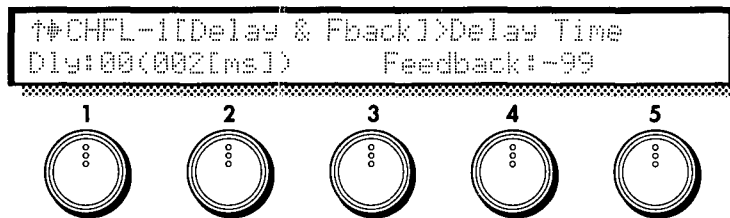

1 Delay Time [0(001[ms])...99(100[ms])]

Set the delay time of the Chorus/Flanger.

3 Feedback [-99...+99]

Set the amount of the output signal that is returned (fed back) into the input. Adjusting this value further away from 0 will produce a more pronounced flanging effect.

•PE62

CHFL-2 [Modulation] - Chorus/Flanger

Specify the LFO that will apply modulation, and a modulation source to control it.

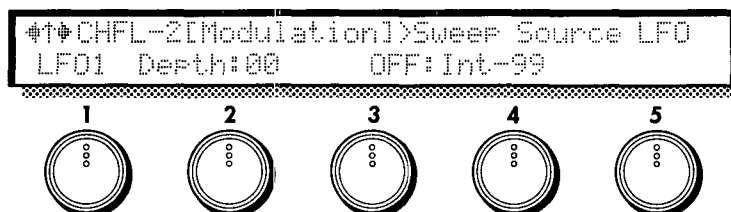

1 LFO Select **[LFO1...4]**

Select the LFO that will apply modulation. LFO settings are made in the LFO section (p.118).

2 LFO Depth **[0...99]**

Set the depth of modulation. Increasing this setting will produce deeper modulation (movement).

•PE63

3 Depth Mod.Source (Depth Modulation Source) **[OFF...CChg#95]**

Select a modulation source to control LFO Depth. (Refer to 6.3 Modulation Source List.)

4 Depth Mod.Int (Depth Mod. Intensity) **[-99...+99]**

Specify the depth and direction of the control that the selected Depth Modulation Source will have. With positive (+) settings, the LFO Depth will be increased, and with negative (-) values it will be decreased. If you have selected EG or LFO as the Depth Mod.Source, positive (+) values will use the original phase, and negative (-) values will invert the phase of the EG or LFO.

CHFL-3 [Fx Balance] - Chorus/Flanger

These parameters set the output balance between the direct sound and the effect sound, and specify a modulation source that will control the balance.

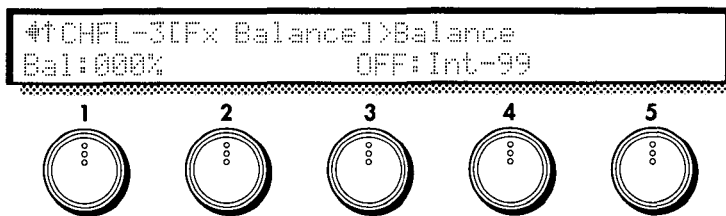

1 Balance (Effect Balance) **[0...100%]**

Set the output balance between the direct sound and effect sound. With a setting of 0 only the direct sound will be output, and with a setting of 100 only the effect sound will be output.

•PE64

3 Bal Mod.Source (Effect Balance Modulation Source) **[OFF...CChg#95]**

Select a modulation source to control Effect Balance. (Refer to 5.3 Modulation Source.)

4 Bal Mod.Intensity (Effect Balance Modulation Intensity) **[-99...+99]**

Specify the depth and direction of the control that the selected Effect Balance Modulation Source will have. With positive (+) settings, the Effect Balance will be raised, and with negative (-) values it will be lowered. If you have selected EG or LFO as the Effect Balance Modulation Source, positive (+) values will use the original phase, and negative (-) values will invert the phase of the EG or LFO.

[UTY] - Utility

* These pages will appear if CHORUS&DELAY has been selected for Delay/Reverb Select (page FX-2,2).

CDU-1 [Initialize]

This utility command initializes the delay or chorus/flanger parameter settings of the currently selected program.

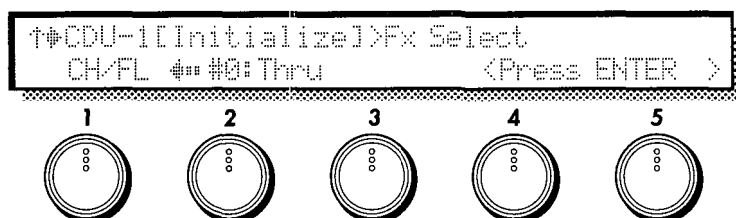

1 Fx Select

[CH/FL, DELAY, CH&DLY]

Select the effect to be initialized.

2 Initial Source

[#0...5] / [#0...4] / [#0...2]

Select one of the following basic settings.

If CH/FL is selected for Fx Select:

- #0:Thru
- #1:LightChorus
- #2:DeepChorus
- #3:LightFlanger
- #4:DeepFlanger
- #5:FlangingDelay

If DELAY is selected for Fx Select:

- #0:Thru
- #1:LongDelay
- #2:MediumDelay
- #3:ShortDelay
- #4:SpringReverb

If CH&DLY is selected for Fx Select:

- #0:Thru
- #1:StereoTapDly
- #2:3D_Delay

Make the desired selection, and press the ENTER key to execute.



If you execute #1 ~ #4 of CH/FL and #1, #2 of CH & DLY, the LFO4 setting will also be altered.

CDU-2 [Copy]

This utility command copies the delay or chorus/flanger settings from another program to the currently selected program.

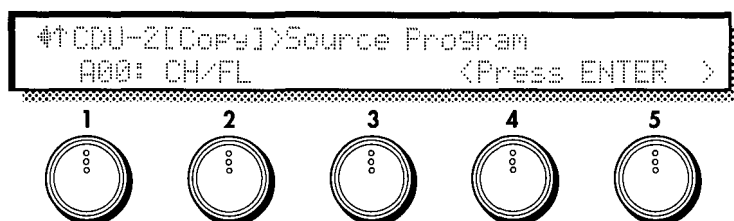

1 Source Program

[A00...C63]

Select the copy source program.

If you have selected C00~C63 and if no card is inserted, the display will indicate <No Card>, and the operation will be halted.

If an unformatted card is inserted, the display will indicate <Illegal Format>, and the operation will be halted.

2 Destination (Target Fx)

[CH/FL, DELAY, CH/FL&DLY]

Select the effect(s) that you wish to copy.

CH/FL : Chorus/Flanger

DELAY : Delay

CH/FL&DLY : Chorus/Flanger&Delay

Select the desired setting and press the ENTER key to execute.

[REVERB] - Reverb

* These parameters will be displayed when REVERB has been selected for Delay/Reverb Select (page FX-2,2).

Reverb is an effect that adds reverberance to the sound. This is a mono-in stereo-out reverb.

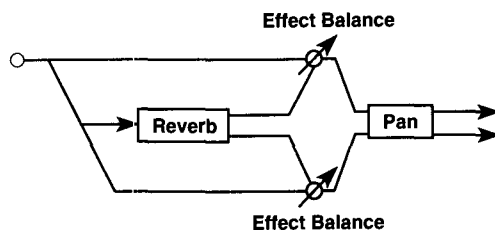

REV-1 [Reverb Time] - Reverb

Set the pre-delay, the reverb time, and the high damp.

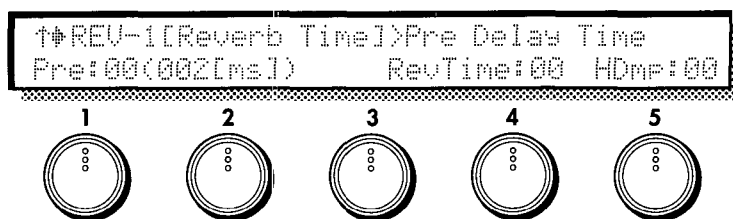

1 Pre Delay Time

[0(002[ms])...99(200[ms])]

Set the time delay between the direct sound and the early reflections.

4 Reverb Time

[0...99]

Set the time over which the reverberant sound will decay.

5 High Damp

[0...99]

Set the amount of attenuation which is applied to the high frequencies of the feedback signal. As this value is increased, the high frequencies will decay faster.

REV-2 [Fx Balance] - Reverb

These parameters set the output balance between the direct sound and the effect sound, and select a modulation source that will control the balance.

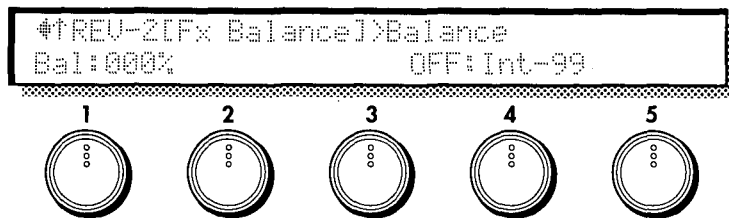

1 Balance (Effect Balance) [0...100%]

Set the output balance between the direct sound and the effect sound. With a setting of 0 only the direct sound will be output, and with a setting of 100 only the effect sound will be output.

•PE71

3 Bal Mod.Source (Effect Balance Modulation Source) [OFF...CChg#95]

Select a modulation source to control Effect Balance. (Refer to 6.3 Modulation Source.)

4 Bal Mod.Intensity (Effect Balance Modulation Intensity) [-99...+99]

Specify the depth and direction of the control that the selected Effect Balance Modulation Source will have. With positive (+) settings, the Effect Balance will be raised, and with negative (-) values it will be lowered. If you have selected EG or LFO as the Effect Balance Modulation Source, positive (+) values will use the original phase, and negative (-) values will invert the phase of the EG or LFO.

[UTY] - Utility

* These pages will appear if REVERB has been selected for Delay/Reverb Select (page FX-2,2).

REU-1 [Initial]

This utility command initializes the reverb parameters of a selected program.

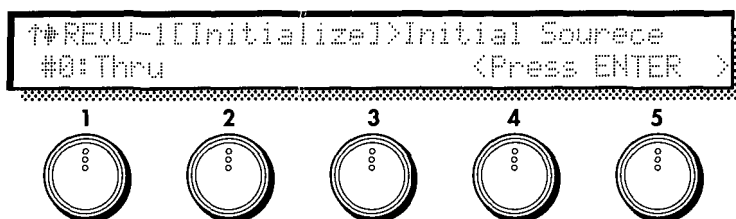

1 Initial Source

[#0...6]

Select one of the following basic settings.

- #0:Thru (no effect)
- #1:Hall
- #2:Room
- #3:Plate
- #4:DelayReverb
- #5:Stage
- #6:EarlyRefraction

Select the desired setting, and press the ENTER key to execute.

REU-2 [Copy]

This utility command copies the reverb parameters from another program to the currently selected program.

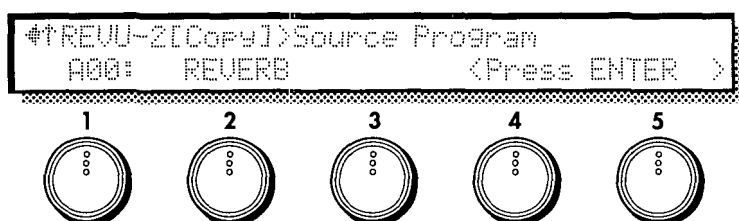

1 Source Program

[A00...C63]

Select the copy source program.

If you have selected C00--C63 and if no card is inserted, the display will indicate <No Card>, and the operation will be halted. If an unformatted card is inserted, the display will indicate <Illegal Format>, and the operation will be halted.

Select the desired copy source, and press the ENTER key to execute.

FX-3 [Dual Peaking EQ] - 2 Band PEQ

This is the menu page for the 2-band parametric equalizer page.

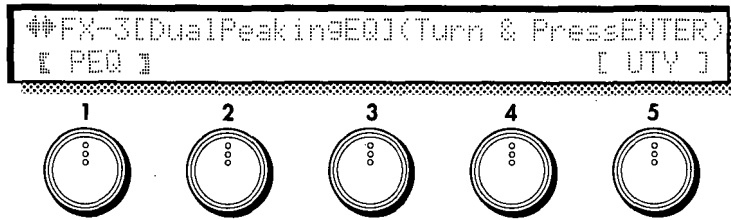

1 [PEQ] (2 Band PEQ)

5 [UTY] (Utility)

Select parametric equalizer settings for editing, or the utility function. [PEQ] accesses the parametric equalizer, and [UTY] allows you to initialize or copy parametric equalizer settings. Use the CURSOR keys or the knobs to select the item you wish to edit, and press the ENTER key to enter the selected page.

[PEQ] - 2 Band Parametric EQ

This is a 2-band parametric equalizer.



PEQ-1 [High EQ] - 2 Band PEQ

Adjust the cutoff frequency of the high range, and set the bandwidth and gain.

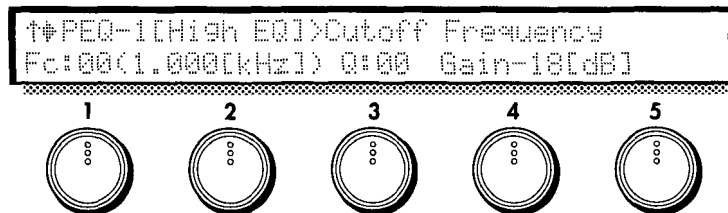

1 Cutoff Frequency [0(1.000[kHz])...49(16.95[kHz])]

Set the center frequency of the High EQ.

3 Q (High Q) **[0...29]**

Set the bandwidth for the High EQ. As this value is increased, the bandwidth will become narrower.

4 Gain (High Gain) **[-18...+18dB]**

Set the amount by which the center frequency range specified by High Freq will be boosted or cut.

PEQ-2 [Low EQ] - 2 Band PEQ

Adjust the cutoff frequency of the low range, and set the bandwidth and gain.

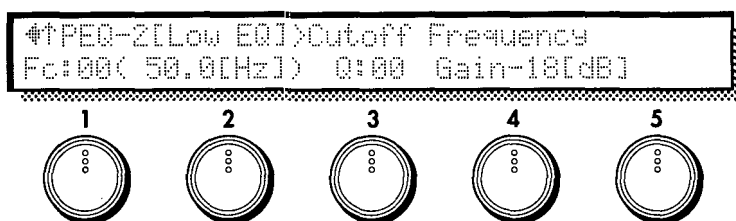

1 Cutoff Frequency **[0(50.0[Hz])...49(6.40kHz)]**

Set the center frequency of the Low EQ.

3 Q (Low Q) **[0...29]**

Set the bandwidth for the Low EQ. As this value is increased, the bandwidth will become narrower.

4 Gain (Low Gain) **[-18...+18dB]**

Set the amount by which the center frequency range specified by Low Freq will be boosted or cut.

[UTY] - Utility

EQU-1 [Initialize]

This utility command initializes the 2 Band PEQ parameters of the currently selected program.

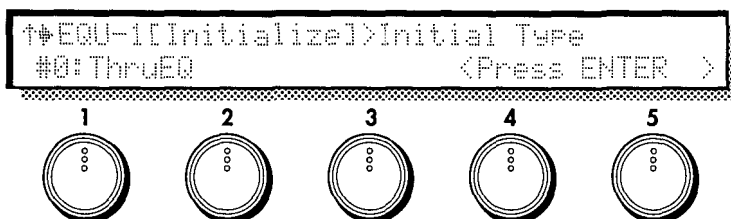

1 Initial Type

[#0...#6]

Select one of the following basic settings.

- #0:ThruEQ
- #1:2BandExciter
- #2:BrightEQ
- #3:SoftEQ
- #4:LowBoost
- #5:ReedEQ
- #6:BrassEQ

Select the desired setting and press the ENTER key to execute.

EQU-2 [Copy] - 2 Band PEQ Utility

This utility command copies the 2 Band PEQ settings of another program to the currently selected program.

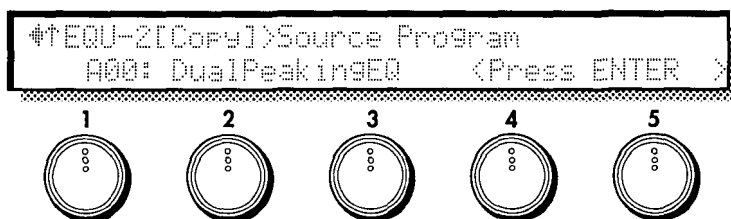

1 Source Program

[A00...C63]

Select the copy source program.

If you have selected C00~C63 and if no card is inserted, the display will indicate <No Card>, and the operation will be halted. If an unformatted card is inserted, the display will indicate <Illegal Format>, and the operation will be halted.

FX-4 [Panpot & Output Level] - Panpot & Level

These parameters set the L/R pan position of the output signal, and specify a modulation source to control it. The output level setting for the entire program is also made here.

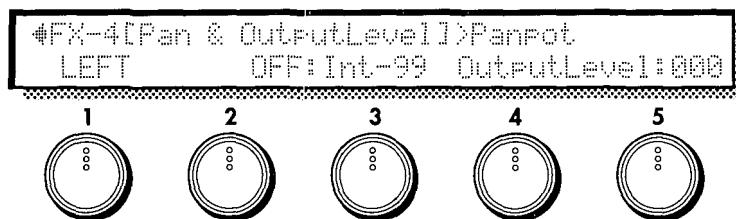

1 Panpot [LEFT, L←63...CENTER...62→R, RIGHT]

Set the L/R pan position of the output signal. A setting of LEFT places the signal fully left, and a setting of RIGHT fully right.

•PE72

2 Panpot Mod.Src (Panpot Modulation Source) [OFF...CChg#95]

Select a modulation source to control Panpot. (Refer to 6.3 Modulation Source List.)

3 Panpot Mod.Int (Panpot Mod. Intensity) [-99...+99]

Specify the depth and direction of the control that the selected Panpot Modulation Source will have. With positive (+) settings, the Panpot value will be raised, and with negative (-) values it will be lowered. If you have selected EG or LFO as the Panpot Modulation Source, positive (+) values will use the original phase, and negative (-) values will invert the phase of the EG or LFO.

5 Output Level [0...127]

Set the output level for the entire effect system.

4-7. EG (Envelope Generator) Section

Here you can make settings for the four general-purpose EGs (envelope generators). Each EG can be used as a modulation source for parameters in any section (other than EG, COMMON, or GLOBAL) to apply time-variant change.

EG-1 [EG Menu]

This is the EG menu page.

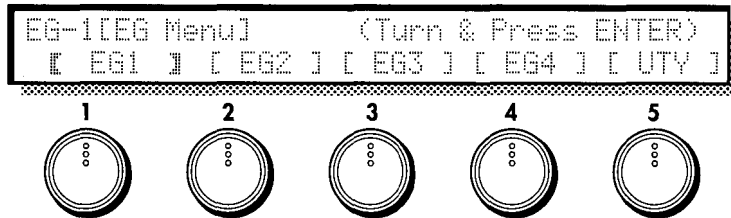

1 [EG1]

2 [EG2]

3 [EG3]

4 [EG4]

5 [UTY] (Utility)

Select the EG that you wish to edit, or select the utility page. [EG1]~[EG4] contain the settings for each EG. [UTY] allows you to initialize or copy EG settings.

Use the CURSOR keys or rotate the knobs to select the desired item, and press the ENTER key to enter the selected page. The parameter structure is identical for [EG1]~[EG4]. For [EG2]~[EG4] refer to the explanation for EG1-1...EG1-4.

[EG1]

EG1-1 [EG Level]

These parameters set the levels for EG1.

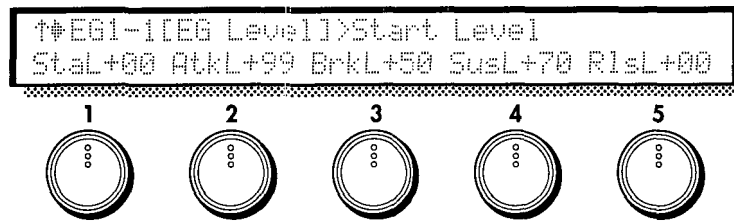

1 Start Level [-99...+99]

Set the level at key-on.

•PE73 : EG1 •PE87 : EG2 •PE101 : EG3 •PE115 : EG4

2 Attack Level [-99...+99]

Set the level that will be reached after the Attack Time elapses.

•PE75 : EG1 •PE89 : EG2 •PE103 : EG3 •PE117 : EG4

3 Break Level [-99...+99]

Set the level that will be reached after the Decay Time elapses.

•PE77 : EG1 •PE91 : EG2 •PE105 : EG3 •PE119 : EG4

4 Sustain Level [-99...+99]

Set the level that will be reached after the Slope Time elapses.

•PE79 : EG1 •PE93 : EG2 •PE107 : EG3 •PE121 : EG4

5 Release Level [-99...+99]

Set the level that will be reached after the Release Time elapses after key-off.

•PE81 : EG1 •PE95 : EG2 •PE109 : EG3 •PE123 : EG4

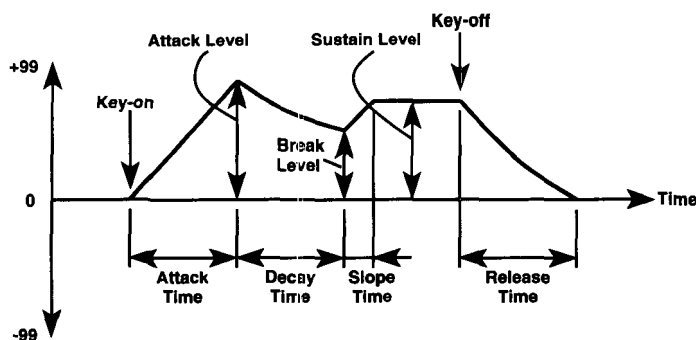

EG1-2 [EG Time]

These parameters set the times for EG1.

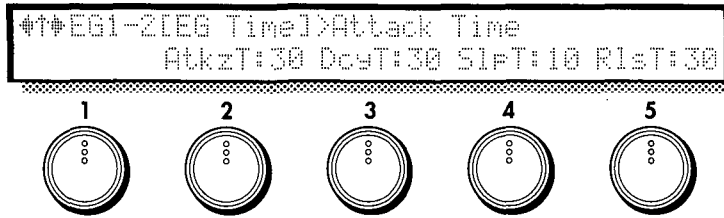

2 Attack Time [0...99]

Set the time from key-on until the Attack Level value is reached.

•PE74 : EG1 •PE88 : EG2 •PE102 : EG3 •PE116 : EG4

3 Decay Time [0...99]

Set the time from when the Attack Time ends until the Break Point value is reached.

•PE76 : EG1 •PE90 : EG2 •PE104 : EG3 •PE118 : EG4

4 Slope Time [0...99]

Set the time from when the Decay Time ends until the Sustain Level value is reached.

•PE78 : EG1 •PE92 : EG2 •PE106 : EG3 •PE120 : EG4

5 Release Time [0...99]

Set the time from key-off until the Release Level is reached.

•PE80 : EG1 •PE94 : EG2 •PE108 : EG3 •PE122 : EG4

EG1-3 [Time KBD TRK] EG Time Keyboard Tracking

These parameters determine how keyboard position will affect EG times.

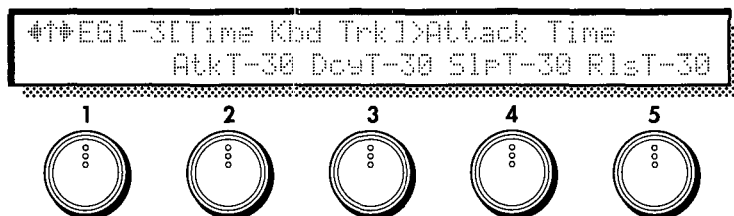

2 Attack Time [-99...+99]

3 Decay Time [-99...+99]

4 Slope Time [-99...+99]

5 Release Time [-99...+99]

Set the depth and direction of the effect that keyboard position will have on each EG time parameter (page EG1-2).

With positive (+) settings, EG times will be lengthened as you play higher notes, and with negative (-) settings they will be shortened.

For negative (-) settings of the Time values:

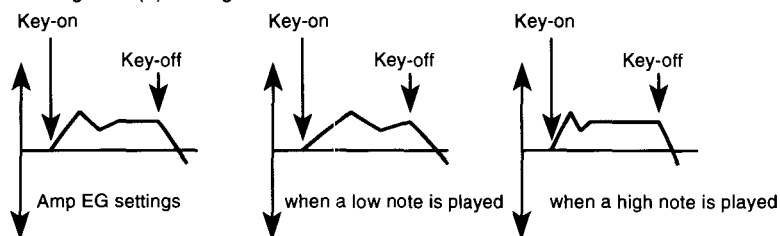

EG1-4 [Velocity Control]

These parameters determine how keyboard playing dynamics (velocity) will affect EG levels and times.

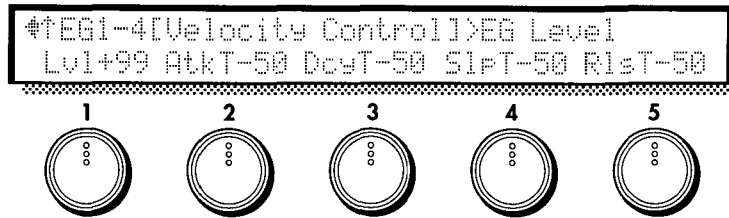

1 EG Level

[-99...+99]

Specify the depth and direction of the effect that velocity will have on EG levels. With positive (+) settings, EG levels will be increased as you play more strongly. With negative (-) settings, EG levels will be decreased as you play more strongly.

•PE82 : EG1 •PE96 : EG2 •PE110 : EG3 •PE124 : EG4

For positive (+) Level settings:

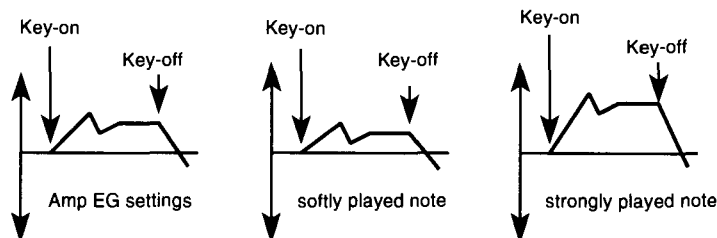

2 Attack Time

[-99...+99]

•PE83 : EG1 •PE97 : EG2 •PE111 : EG3 •PE125 : EG4

3 Decay Time

[-99...+99]

•PE84 : EG1 •PE98 : EG2 •PE112 : EG3 •PE126 : EG4

4 Slope Time

[-99...+99]

•PE85 : EG1 •PE99 : EG2 •PE113 : EG3 •PE127 : EG4

5 Release Time

[-99...+99]

Specify the depth and direction of the effect that velocity will have on EG times. With positive (+) settings, EG times will be lengthened as you play more strongly, and with negative (-) settings they will be shortened.

•PE86 : EG1 •PE100 : EG2 •PE114 : EG3 •PE128 : EG4

For negative (-) settings of the Time parameters:

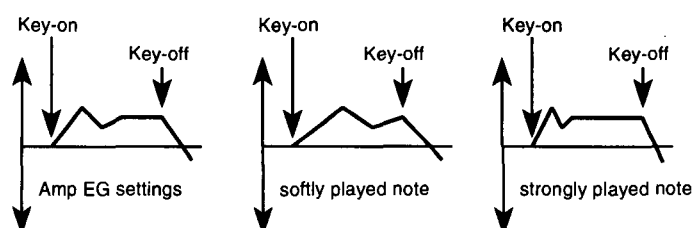

[EG2] EG2-1...4

[EG3] EG3-1...4

[EG4] EG4-1...4

The contents of the parameters are identical to EG1. Refer to the explanations for page EG1-1...4.

[UTY] - Utility

EGU-1 Initialize

This utility command initializes the specified EG (1~4).

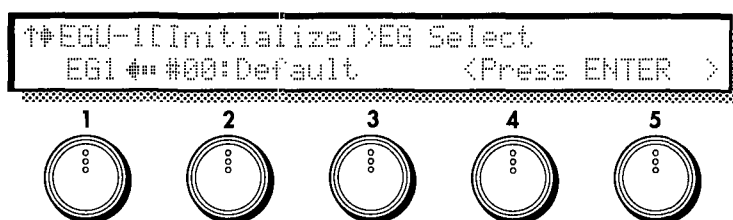

1 EG Select

[EG1...EG4]

Select the EG to initialize.

2 Initial Type

[#00...10]

Select one of the following 11 basic EG settings for the EG specified by EG Select.

- #00:Default
- #01:Piano
- #02:Bell
- #03:Guitar
- #04:Percussion
- #05:Organ
- #06:SoftAttack
- #07:SlowAttack
- #08:SoloString
- #09:Sweep
- #10:Pressure

Select the desired setting and press the ENTER key to execute.

EGU-2 Copy

This utility command copies the EG parameter settings from another program to the currently selected EG.

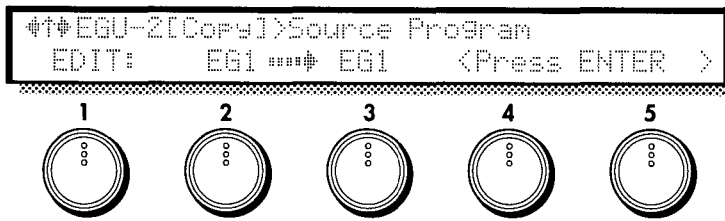

1 Source Program

[EDIT, A00...C63]

Select the copy source program. If you select EDIT, the currently edited program (the program in current memory) will be selected.

If you have selected C00~C63 and if no card is inserted, the display will indicate <No Card>, and the operation will be halted. If an unformatted card is inserted, the display will indicate <Illegal Format>, and the operation will be halted.

2 Source EG

[EG1...4, ALL]

Select the copy source EG. If you select ALL, the following Destination setting will be ignored.

3 Destination (Target EG)

[EG1...4]

Select the copy destination (current) EG.

Make the desired selection, and press the ENTER key to execute.

! If the Source Program is set to EDIT and the Source EG and Destination are identical, the display will indicate <Ignore > and the operation will be halted.

EGU-3 Swap

This utility command exchanges the settings of two EGs within the currently selected program.

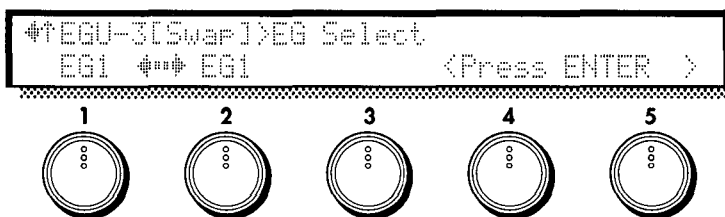

1 EG Select

[EG1...4]

Select one EG program to swap.

2 Another Select

[EG1...4]

Select another EG program to swap EG.

To execute the swap command, press the ENTER key.

4-8. LFO Section

Here you can make settings for the four general-purpose LFOs. These can be used as modulation sources for the parameters of each section (except for COMMON and GLOBAL), allowing you to apply cyclic change to the sound.

LFO-1 [LFO Menu]

This is the LFO menu page.

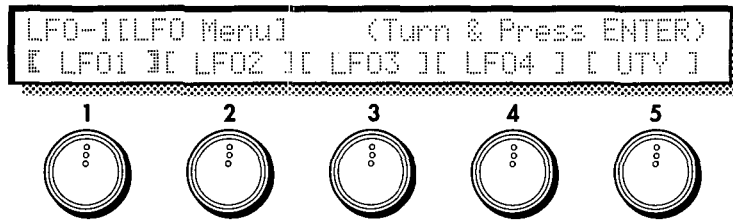

1 [LFO1]

2 [LFO2]

3 [LFO3]

4 [LFO4]

5 [UTY] (Utility)

Select the LFO that you wish to edit, or select the utility functions. [LFO1]~[LFO4] access the settings of each LFO. [UTY] allows you to initialize or copy LFO settings.

Use the CURSOR keys or rotate the knobs to select the desired item, and press the ENTER key to enter the selected page.

The parameter structure of [LFO1]~[LFO4] is identical. For details on [LFO2]~[LFO4], refer to the explanation for LFO1-1...LFO1-4.

[LFO1]

LFO1-1 [Wave & Mode]

These parameters let you select the waveform for LFO1, and specify how key on/off timing will affect the LFO. You can also specify whether or not the LFO period will synchronize itself to begin at key-on.

↑LFO1-1[Wave & Mode]Wave Form
#00:SIN'0 Mode:OFF KeySync:OFF

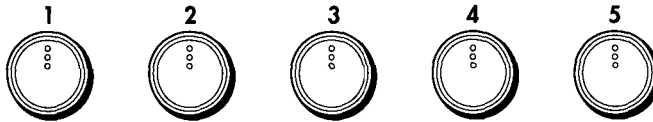

1 Wave Form

[0...29]

Select the LFO waveform.

•PE129 : LFO1 •PE134 : LFO2 •PE139 : LFO3 •PE144 : LFO4

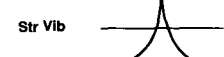
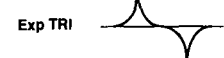
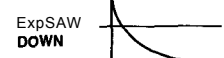
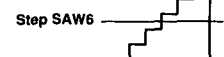
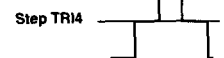
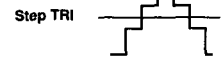
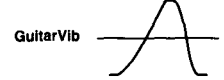
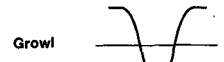
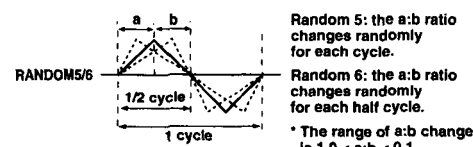
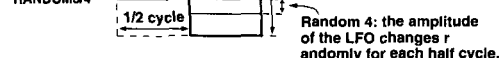
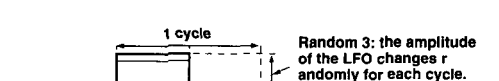
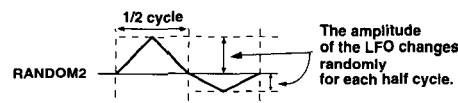
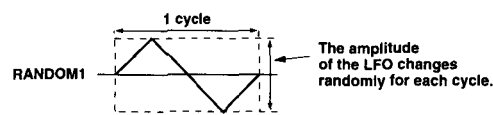
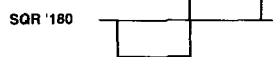
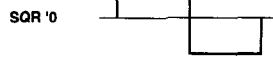
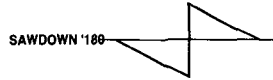
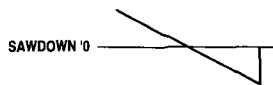
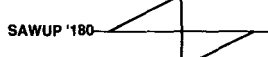
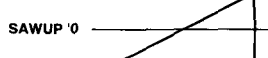
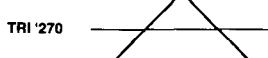
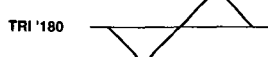
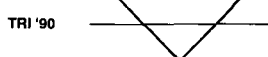
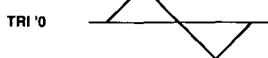
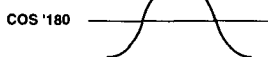
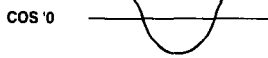
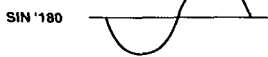

4-8. LFO

3 Mode

[ON, OFF, BOTH]

Specify the time when the LFO begins to apply. This will be affected by the settings of Delay (page LFO1-4,4) and Fade In (page LFO1-4,5).

With a setting of ON, the LFO will begin to apply at key-on. Normally you will set this parameter ON.

With a setting of OFF, the LFO will begin to apply at key-off.

With a setting of BOTH, the LFO will begin to apply at key-on, and will stop at key-off.

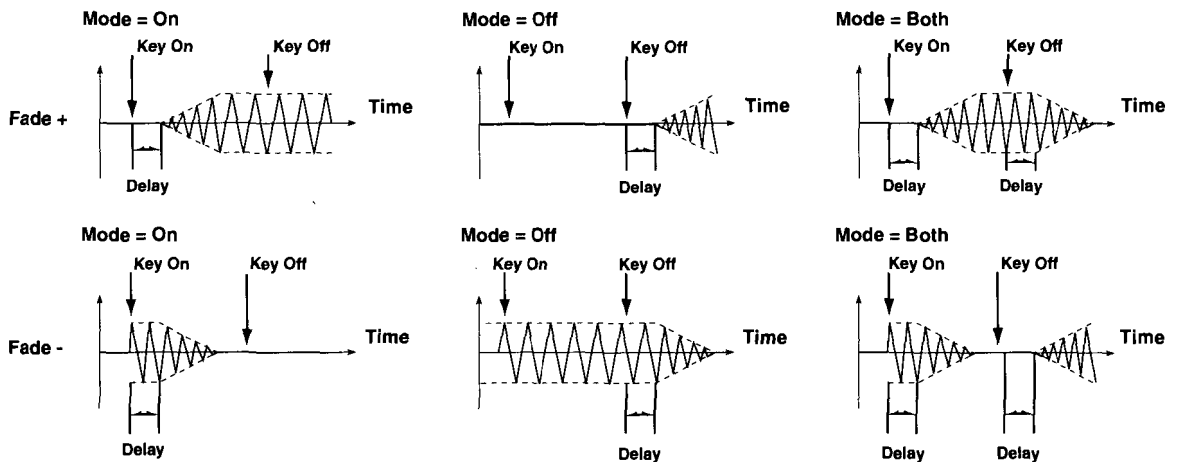

5 Key Sync SW (Key Sync Switch)

[OFF, ON]

With a setting of OFF, subsequently-played notes will use the effect of the LFO that was started by the first-played note. (In this case, the Delay and Fade In settings will have no effect.)

With a setting of ON, the LFO will start again each time a key is pressed, and an independent LFO will operate for each key.

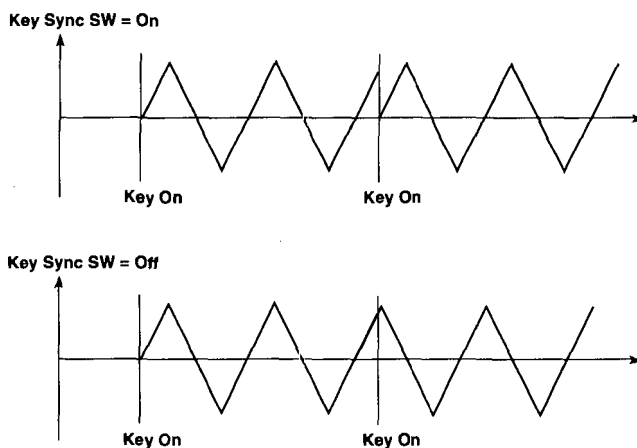

LFO1-2 [Frequency]

These parameters set the speed of the LFO, and specify the depth and direction of the effect that keyboard tracking and control change #1 will have on LFO speed.

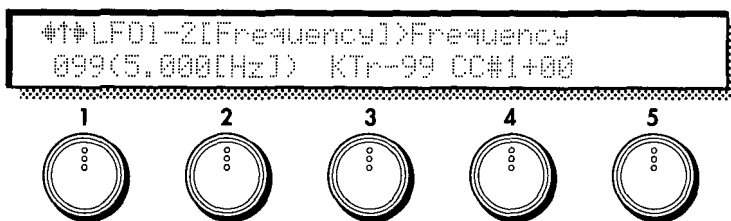

1 Frequency [0(0.000[Hz])...199(60.00[Hz])]

Set the speed of the LFO.

•PE130 : LFO1 •PE135 : LFO2 •PE140 : LFO3 •PE145 : LFO4

3 Frequency Kbd Track (Frequency Keyboard Tracking) [-99...+99]

Specify how keyboard position will affect the LFO speed. With positive (+) settings, the LFO speed will become faster as you play higher notes. With negative (-) settings, the opposite effect will occur.

4 Frequency CC#1 Ctrl (Frequency CC#1 Control) [-99...+99]

Specify how control change #1 will affect the LFO speed.

LFO1-3 [Modulation Source]

These parameters specify a modulation source that will control LFO speed, and set the intensity of the control.

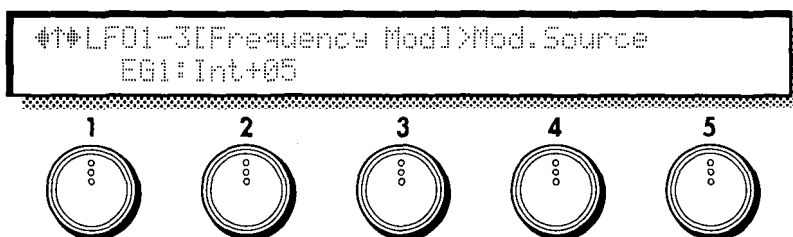

1 Mod.Source (Frequency Modulation Source) [OFF...CChg#95]

Select a modulation source that will control LFO speed. (Refer to 6.3 Modulation Source List.)

2 Mod.Intensity (Frequency Modulation Intensity) [-99...+99]

This specifies the depth and direction of the adjustment that the controller will make to the LFO speed specified by the Frequency setting (page LFO1-2,1). If you have selected EG or LFO as the Frequency Modulation Source, positive (+) values will use the original phase, and negative (-) values will invert the phase of the EG or LFO.

LFO1-4 [Amplitude]

These parameters specify a modulation source that will control the level of the LFO waveform and set the intensity of the control, and also specify how the LFO effect will change over time.

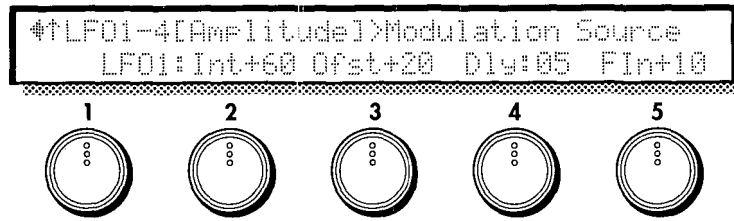

1 Modulation Source (Amplitude Modulation Source) [OFF...CChg#95]

Select a modulation source that will control the level of the LFO waveform. (Refer to 6.3 Modulation Source List.)

2 Modulation Intensity (Amplitude Mod. Intensity) [-99...+99]

Specify the depth and direction of the control that the selected Amplitude Modulation Source will have on the LFO waveform level. If you have selected EG or LFO as the Amplitude Modulation Source, positive (+) values will use the original phase, and negative (-) values will invert the phase of the EG or LFO.

•PE132 : LFO1 •PE137 : LFO2 •PE142 : LFO3 •PE147 : LFO4

3 Offset [-99...+99]

Specify the center value of the LFO waveform.

•PE131 : LFO1 •PE136 : LFO2 •PE141 : LFO3 •PE146 : LFO4

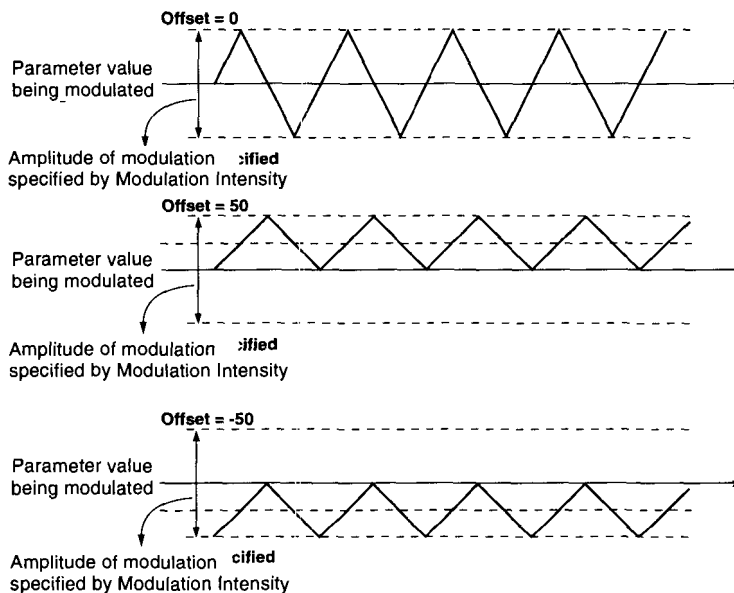

4 Delay [0...99]

Specify the time delay after key-on until the LFO begins to take effect.

5 Fade In [-99...+99]

Specify the time over which the LFO takes full effect. With positive (+) settings, the effect of the LFO will gradually increase up to the full value specified by the parameters. With negative (-) settings, the effect of the LFO will begin with the full value specified by the parameters, and will then gradually diminish to no effect.

•PE133 : LFO1 •PE138 : LFO2 •PE143 : LFO3 •PE148 : LFO4

[LFO2] LFO2-1...4

[LFO3] LFO3-1...4

[LFO4] LFO4-1...4

The [LFO2], [LFO3], and [LFO4] parameters are identical in structure to the [LFO1] parameters. Refer to the explanation for LFO1-1...4.

[UTY] - Utility

LFOU-1 [Copy]

This utility command copies LFO parameter settings from another program to the currently selected LFO.

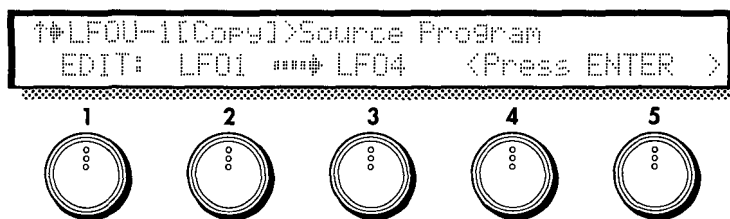

1 Source Program

[EDIT, A00...C63]

Select the copy source program number. If you select EDIT, the program currently being edited (the program called into current memory) will be selected.

If you select C00~C63 and if a card is not inserted when you execute, the display will indicate <No Card>, and the operation will be halted.

If an un-formatted card is inserted, the display will indicate <Illegal Format>, and the operation will be halted.

2 Source LFO

[LFO1...4, ALL]

Select the copy source LFO. If you select ALL, the following Destination setting will be ignored.

3 Destination

(Target LFO)

[LFO1...4]

Select the copy destination (current) LFO.

Make the desired selection, and press the ENTER key to execute.



If the Source Program is EDIT, setting the Source LFO and the Destination to the same settings will result in a message of <Ignore >, and the operation will be halted.

LFOU-2 [Swap]

This utility command exchanges the settings of two LFOs within the same program.

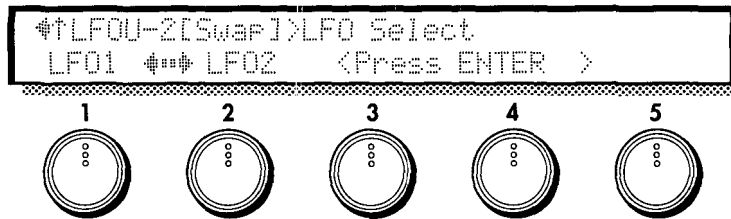

1 LFO Select

[LFO1...4]

Select one of the LFOs to swap.

2 Another Select

[LFO1...4]

Select another of the LFOs to swap.

Make the desired selections, and press the ENTER key to execute.



If LFO Select and Another Select are identical, the display will indicate <Ignore > and the operation will be canceled.

4-9. Common Section

Specify the name of a program, its scale, and controller functions etc.

CMN-1 [Program Name]

Assign a name of up to 16 characters to the program.

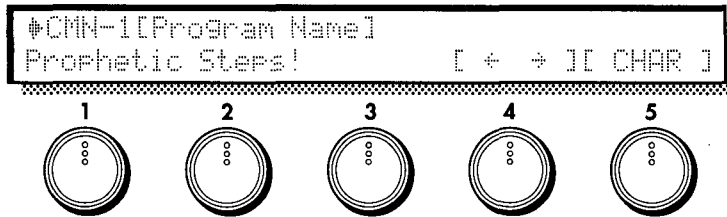

Use knob 4 or the cursor keys to move the CURSOR, and use the VALUE key or knob 5 to select characters. Use the ENTER key to enter a space, and the EXIT key to delete a character.

- ⚠ To name a program, first use the CURSOR keys or knob 4 to make the cursor appear. Then you will be able to select characters.
- ⚠ To save the program name, be sure to write the program into memory. If you select another program or turn the power off, your changes will be lost.

The following characters are available.

	!	"	#	\$	%	&	'	()	*	+	,	-	.	/	0	1	2	3	4	5	6	7	8	9	:	;	<	=	>	?
@	A	B	C	D	E	F	G	H	I	J	K	L	M	N	O	P	Q	R	S	T	U	V	W	X	Y	Z	[\]	^	_
\	a	b	c	d	e	f	g	h	i	j	k	l	m	n	o	p	q	r	s	t	u	v	w	x	y	z					

CMN-2 [Prog Category]-Program Category

Here you can select the category that will be displayed at the right of the program name in Performance Mode.

When selecting programs in Performance mode, you can press the PAGE keys to search for programs that have the same category. This is useful as an auxiliary name or as an index for classifying programs.

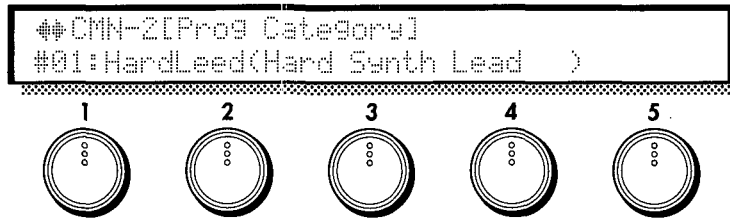

1 Program Category

[#1...16]

Select one of the following 16 program categories.

#01 : HardLead	(Hard Synth Lead)
#02 : SoftLead	(Soft Synth Lead)
#03 : SynthBss	(Synth Bass)
#04 : RealBass	(Real String Bass)
#05 : GtrPluck	(Guitar/Plucked)
#06 : Brass	(Brass)
#07 : Reed	(Reed)
#08 : Wind	(Wind)
#09 : Bell	(Bell)
#10 : Keyboard	(Keyboard)
#11 : Perc	(Percussive)
#12 : Motion	(Motion)
#13 : SFX/etc.	(Sound Effect/Other)
#14 : Arpeggio	(Arpeggiator)
#15 : UserGrp1	(User Group 1)
#16 : UserGrp2	(User Group 2)

CMN-3 [Voice Control]

These parameters determine how processing will take place when a note is played.

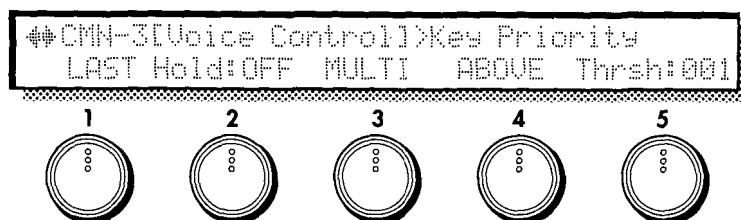

1 Key Priority [LAST, HIGH, LOW]

This setting determines which note will sound when two or more keys are pressed simultaneously.

LAST: The last-pressed note will sound.

LOW: The lowest of the simultaneously pressed notes will sound.

HIGH: The highest of the simultaneously pressed notes will sound.

2 Hold [OFF, ON]

This parameter specifies whether or not a note will continue sounding after the key is released. When Hold is ON, a note will continue to sound even after the key is released. However if the Sustain Level is set to 0 for the EG selected as the Amp Mod. EG (in AMP section page AMP1-2,1 or 2-2,1), the sound will decay naturally.

3 Trigger Mode [MULTI, SINGLE, VELOCITY]

This parameter determines how the EG and LFO will be affected by key-on.

MULTI (multi trigger): For every key-on, EGs will begin operation from the Start Level, and LFOs whose Key Sync (page LFO1~4-1,5) is ON will be reset.

SINGLE (single trigger): When (and only when) a key-on occurs when all keys are off, EGs will return to the Start Level and LFOs (whose Key Sync is ON) will be reset.

VELOCITY (velocity): Multi trigger and Single trigger will be switched depending on the velocity.

4 Above Below [ABOVE, BELOW]

Refer to 5 Threshold Velocity.

5 Threshold Velocity [1...127]

When the Trigger Mode is set to VELOCITY, this parameter specifies the velocity value at which Multi and Single triggering will be switched. If the Above Below parameter is set to ABOVE, Multi trigger will be used for notes with a velocity above the Threshold Velocity. If the Above Below parameter is set to BELOW, Multi triggering will be used for notes with a velocity below the Threshold Velocity.

CMN-4 [Scale]

These parameters specify the scale. You can also cause the pitch to be randomly varied from the selected scale.

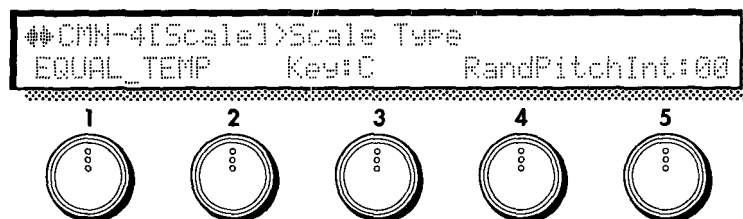

1 Scale Type

[EQUAL_TEMP...USER_SCALE_2]

Select one of the following 16 types of scale.

EQUAL TEMPERAMENT:

This is the most commonly used scale, in which each semitone interval is identical to all others.

PURE MAJOR:

In this scale, the principle major chords in the key selected by Scale Key will be perfectly in tune.

PURE MINOR:

In this scale, the principle minor chords in the key selected by Scale Key will be perfectly in tune.

ARABIC:

This is a quarter-tone scale used in Arabian music. For "rast do/bayati re" set Scale Key to C; for "rast re/bayati mi" use D; for "rast fa/bayati sol" use F; for "rast sol/bayati la" use G; for "rast si flat/bayati do" use A#.

PYTHAGOREAN:

This scale takes its name from the famous mathematician of ancient Greece, and is effective for melodic playing.

WERCKMEISTER:

This is a scale used in the later Baroque period.

KIRNBERGER:

This is a scale created in the 18th century for the harpsichord.

SLENDRO:

This is an Indonesian Gamelan scale in which octaves consist of five notes. When the Scale Key is C, the notes C, D, F, G, and A are used.

PELOG:

This is an Indonesian Gamelan scale in which octaves consist of seven notes. When the Scale Key is C, the notes C, D, E, F, G, A, and B are used.

USER SCALE 1:

This is a user-adjustable scale that allows you to specify the pitch of each note in the octave. The specified pitches are applied to each octave. Make settings in Global section page GLB-3.

USER SCALE 2:

This is a user-adjustable scale that allows you to specify the pitch of each note in the entire range (C-1~G9). Make settings in Global section page GLB-3.

3 Scale Key

[C...B]

Specify the key (tonic) of the scale.

5 Random Pitch Intensity

[0...99]

Specify the depth at which the pitch will be varied randomly.

Higher settings of this parameter will produce an increasing degree of randomness in the pitch of each note when it is played. Normally you will leave this set to 0. This parameter is useful when you wish to simulate instruments whose pitch is inherently unpredictable, such as analog synthesizers or acoustic instruments.

CMN-5 [Wheel1/2 Assign]

These parameters specify the function of Wheel Controllers 1 and 2.

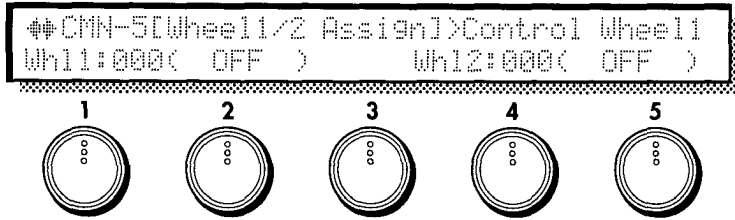

1 Control Wheel 1

[0(OFF)...100(CChg#95)]

Specify the function of the Wheel 1 controller. You can select from Pitch Bend (+/-, +, -), Aftertouch, and Control Change numbers 0~95.

4 Control Wheel 2

[0(OFF)...100(CChg#95)]

Specify the function of the Wheel 2 controller. You can select from Pitch Bend (+/-, +, -), Aftertouch, and Control Change numbers 0~95.



CMN-6 [Wheel3 Assign] - Wheel Controller3 Assign

These parameters specify the functions of the Wheel 3 controller.

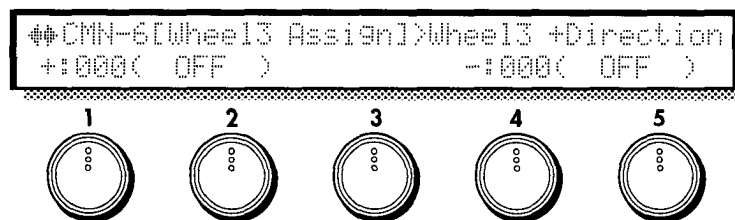

1 Wheel3 +Direction

[0(OFF)...100(CChg#95)]

Specify the function of the Wheel 3 controller when it is moved away from yourself. You can select from Pitch Bend (+/-, +, -), Aftertouch, and Control Change numbers 0~95 (refer to the diagram on the following page).

4 Wheel3 -Direction

[0(OFF)...100(CChg#95)]

Specify the function of the Wheel 3 controller when it is moved toward yourself. You can select from Pitch Bend (+/-, +, -), Aftertouch, and Control Change numbers 0~95 (refer to the diagram on the following page).

CMN-7 [Ribbon Assign]

These parameters specify the function of the Ribbon controller, and specify the location on the X-axis which will be the zero point.

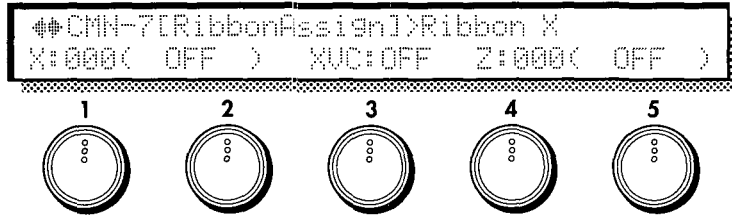

1 Ribbon X (RibbonController-X) [0(OFF)...100(CChg#95)]

Specify the function that the Ribbon controller will have when it is moved to left or right. You can select from Pitch Bend (+/-, +, -), Aftertouch, and Control Change numbers 0~95.

3 X Variable Center(X Variable 0 Point) [OFF, ON]

When this is set OFF, the center of the Ribbon controller will be 0.
 When this is set ON, the location where you begin stroking horizontally will be 0.

4 Ribbon Z (RibbonController-Z) [0(OFF)...100(CChg#95)]

Specify the function that the Ribbon controller will have when it is pressed strongly. You can select from Pitch Bend (+/-, +, -), Aftertouch, and Control Change numbers 0~95.

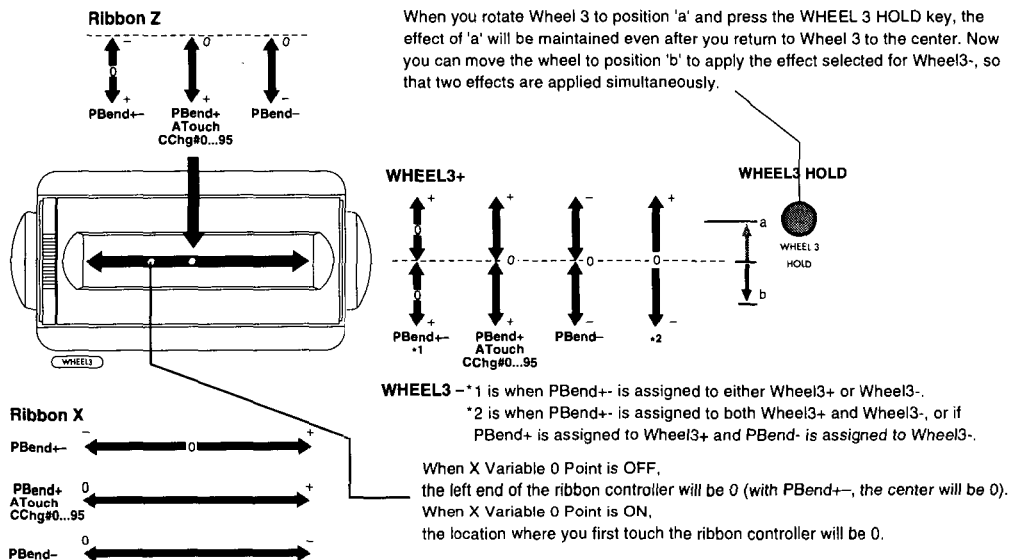

! Please be aware that if you assign PBend+/- to Ribbon Z, or to either Wheel 3+ or Wheel 3-, modulation may keep being applied continuously for some settings.

CMN-8 [Pedal & SW Assign]

These parameters specify the functions controlled by the optional expression pedal and foot switch.

For details, refer to the explanation of connections in the Basic Guide.

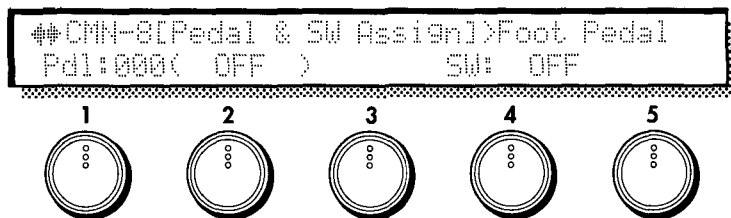

1 FootPedal [0(OFF)...100(CChg#95)]

Specify the function that will be controlled when the expression pedal is operated. You can select from Pitch Bend (+/-, +, -), Aftertouch, and Control Change numbers 0~95.

4 Foot SW (Foot Switch) [OFF...Wh3Hold]

Specify the function that the foot switch will have. You can select from the following 12 functions.

Off	No effect
Sustain	Sustain on/off
Octave Up	1 octave up
Octave Down	1 octave down
Portamento SW	Portamento on/off
Distortion SW	Distortion on/off
Wah SW	Wah on/off
Chorus SW	Chorus on/off
Delay SW	Delay on/off
Reverb SW	Reverb on/off
Arpeggio OFF/ON	Arpeggiator function on/off
Wheel3 Hold	Wheel 3 hold on/off

CMN-9 [Copy Control]

This command copies controller settings from another program to the currently selected program.

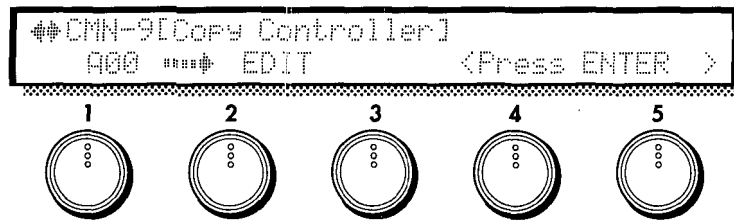

1 Source Program

[A00...63, B00...63, C00...63(CARD)]

Select the copy source program from A00~63, B00~63, or C00~63 (CARD).

The settings for WHEEL 1/2, WHEEL 3 +/-, RIBBON X/Z, and FOOT PEDAL/SW will be copied.

To execute the Copy command, press the ENTER key.

CMN-10 [Initialize Program]

Initialize the currently selected program.

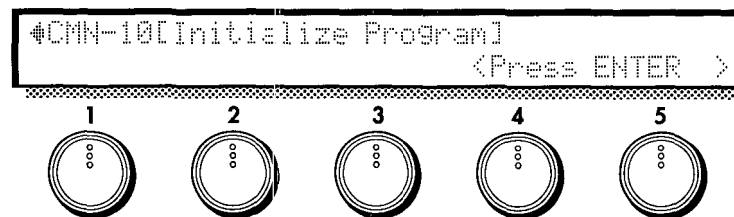

To initialize, press the ENTER key.

4-10. Global Section

These parameters determine the overall basic tuning of the Prophecy synthesizer, and determine how MIDI data will be transmitted, received, and converted.

GLB-1 [Tune & Transpose]

These parameters set the tuning, and specify how volume and tone will be affected by velocity and aftertouch.

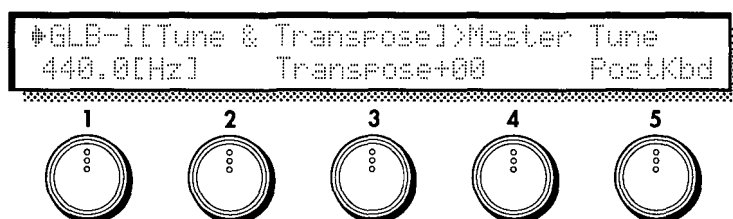

1 Master Tune [Hz] [430.0...450.0]

Adjust the overall pitch of the Prophecy synthesizer in 0.1 Hz steps over a range of 430.0 Hz to 450.0 Hz. Use this setting to tune the Prophecy to your other instruments.

4 Transpose [-12...+12]

Adjust the overall pitch of the Prophecy synthesizer in semitone steps (100 cents) over a range of 1 octave up or down. Use this setting to transpose a song, etc.

5 Xpose Position (Transpose Position) [PostKbd, PreTG]

This setting determines the point at which processing will be done for the Transpose setting, the Velocity Curve (p.134), and the Aftertouch Curve (p.134). These settings will affect the way MIDI messages are received. These settings will not affect the way that the internal tone generator of the Prophecy itself will sound in response to its own keyboard.

With a setting of Post Kbd, processing will take place immediately after the keyboard. This means that the Note Number, Velocity, and Aftertouch values generated by the keyboard will be converted by the specified values or curves before being sent to the internal tone generator and from MIDI OUT. MIDI messages received from MIDI IN will not be affected.

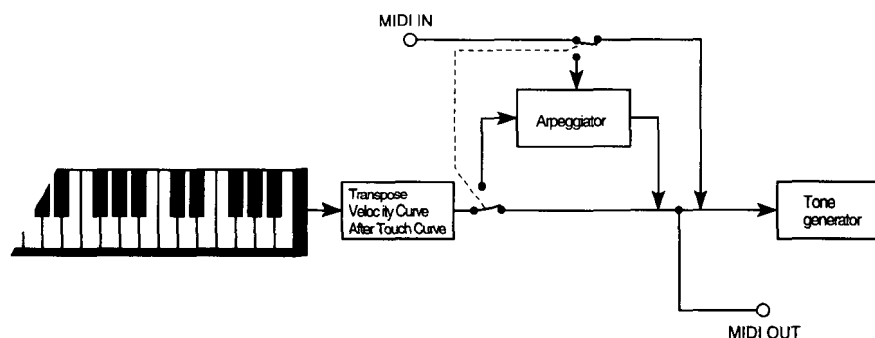

With a setting of PreTG, the Note Numbers, Velocity, and Aftertouch values that are input to the tone generator will be converted by the specified values or curves before being sounded by the internal tone generator. MIDI messages transmitted from MIDI OUT will not be affected.

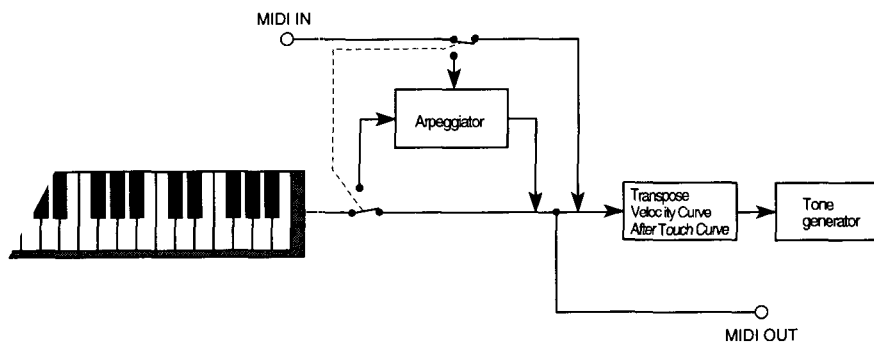

GLB-2 [Curve & Effects]

Make settings for velocity, aftertouch sensitivity, and reverb/delay bypass.

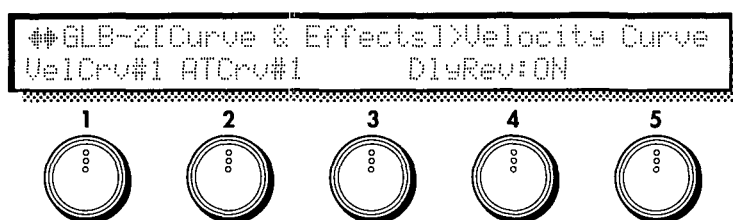

1 Velocity Curve

[1...8]

Select one of 8 types of curve by which velocity (keyboard playing dynamics) will cause changes in volume or tone.

This setting will be affected by the Transpose Point (p.133).

Vel. Curve

- 1: Significant differences will appear only for strongly played notes
- 2: :
- 3: :
- 4: A normal curve
- 5: :
- 6: Significant differences will appear even for moderately strong notes
- 7: Moderately played notes will have little difference, and the effect will be fairly even
- 8: Moderately played notes will have little difference, and the effect will be fairly even (flatter than 7)

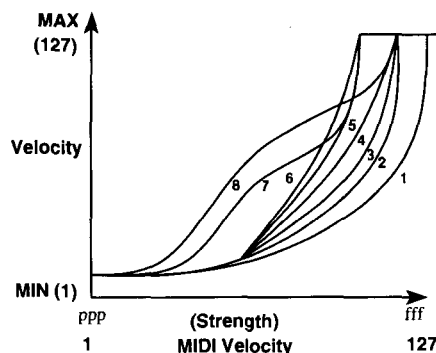

Since curves 7 and 8 produce little change for notes of moderate strength, they are suitable for when you do not need velocity or for when you want notes to have an even strength. However control will be more difficult, since softly played notes will have wider variations.

2 AfterTouchCurve

[1...8]

Select one of 8 types of curve by which aftertouch (the pressure that you apply to the keyboard after playing a note) will affect volume or tone.

This setting will be affected by the Transpose Point (p.133).

After Touch Curve

- 1: Significant effect will appear only if you press fairly strongly
- 2: :

- 3: A normal curve
- 4: :
- 5: Significant effect will appear even for light pressure
- 6: Abrupt change (24 steps)
- 7: Even abrupter change (12 steps)
- 8: Random

Curves 6 and 7 will produce stepped change of 12 or 24 steps. Since curve 7 produces a change in 12 steps, you can set a pitch width of 1 octave to be controlled by Aftertouch, and apply pressure on the keyboard to change the pitch in semitone steps. Curve 8 is random. Use it for special effects, or when you want to use Aftertouch to apply unpredictable modulation.

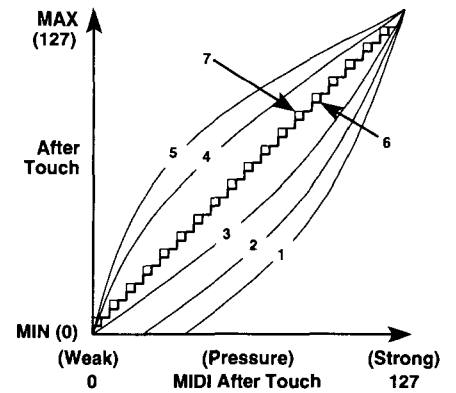

4 DelayReverb (Delay & Reverb Bypass) [ON, BYPASS]

Make this setting when you do not wish to use the built-in delay or reverb. With a setting of BYPASS, the delay and reverb will be bypassed and will have no effect.

GLB-3 [User Scale]

These parameters let you create user-defined scales. For User Scale 1 you can specify a detuning value for each note of the octave, and your settings will be applied to all octaves of the full range. For User Scale 2 you can specify a detuning value for each of the 128 notes (C-1~G9) of the full range.

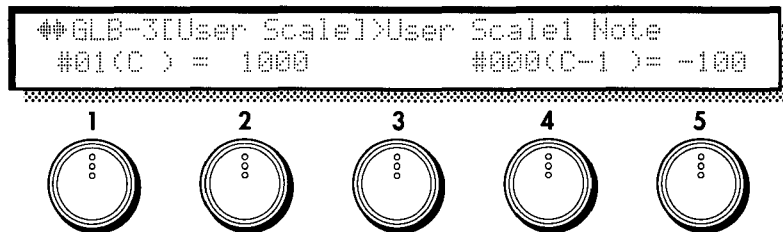

1 User Scale 1 Note [1(C)...12(B)]

Select the note of the octave that you wish to detune.

2 Scale 1 Detune [-100...+100]

For the note selected by User Scale 1 Note, specify a detune value of -100 to +100 cents. The setting is relative to equal temperament (0). With a setting of -100 the pitch will be a semitone lower than standard pitch, and with a setting of +100 the pitch will be a semitone higher than standard pitch.

4 User Scale2 Key [0(C-1)...127(G9)]

Select the note number that you wish to detune.

5 Scale 2 Detune [-100...+100]

For the note number selected by User Scale 2 Key, specify a detune value of -100 to +100 cents. The values of the setting are the same as for Scale 1 Detune.

GLB-4 [Sens&Polar]-Sensitivity & Polarity

These parameters specify the sensitivity of the pressure-type controllers, and the polarity of the foot switches, etc.

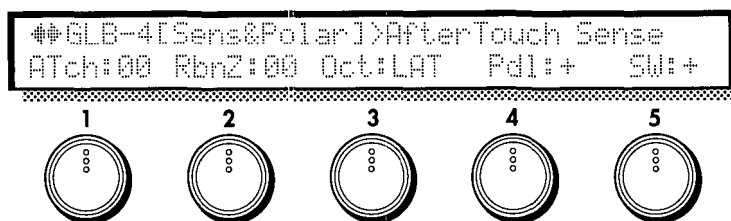

1 AfterTouch Sense [0...99]

Set the sensitivity of aftertouch. Higher settings will make aftertouch more sensitive.

With a setting of 0 aftertouch will have no effect. The results will depend on the Aftertouch Curve that is selected. The diagram below shows the case of Aftertouch Curve 3.

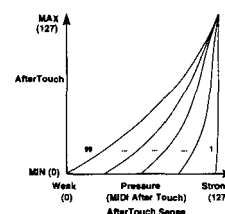

2 Ribbon Z Sense [0...99]

Set the sensitivity of the ribbon controller to pressure. Higher settings will make the ribbon controller more sensitive. With a setting of 0 the ribbon controller will have no effect.

3 Octave SW Mode (Octave Switch Mode) [LAT, ULAT]

Set the operation mode of the front panel OCTAVE UP/DOWN switches.

LAT (latched): Each time you press an OCTAVE UP/DOWN button in Performance mode, the pitch will go up/down one octave, and the OCTAVE UP/DOWN key will light. If you press the UP key once again when the UP LED is lit, the UP LED will then start blinking, and the pitch will rise two octaves above the original pitch. Pressing the UP key when the UP LED is lit or blinking will cause the pitch to alternate between one octave and two octaves higher than the original pitch. Pressing the DOWN key while the UP LED is lit will bring the pitch back to the original pitch, and pressing the DOWN key while the UP LED is blinking will bring the pitch back to one octave above the original pitch. The same applies in the downward direction.

ULAT (unlatched): The pitch will go up/down one octave only while you continue pressing an OCTAVE UP/DOWN button in Performance mode.

4 FootPedal Polarity [+, -]

Set the polarity of the foot pedal connected to the rear panel. For details, refer to section "2.1 Setup" in the Players/Basic Guide.

The Foot Pedal Polarity setting determines how pressing and returning the expression pedal (optional; XVP-10 or EXP-10, etc.) will increase or decrease the value of the parameter which it is controlling. With a setting of "+" the value will be increased when the pedal is pressed. With a setting of "-" the opposite will occur.

5 Foot SW Polarity (Foot Switch Polarity) [+, -]

Set the polarity of the foot switch connected to the rear panel. For details, refer to section "2.1 Setup" in the Players/Basic Guide. Either open-type (↑) or closed-type (↓) foot switches may be used.

The Foot SW Polarity setting determines how pressing and releasing the foot switch will switch the parameter which it is controlling. With a setting of "+" the parameter will be turned on when the foot switch is pressed. With a setting of "-" the parameter will be turned on when the foot switch is released.

GLB-5 [Knob Controller Assign]

These settings assign the message that each knob will transmit from MIDI OUT; Pitch Bender, Aftersustain, or Control Change etc. In Performance mode, the five knobs will always function as controllers.

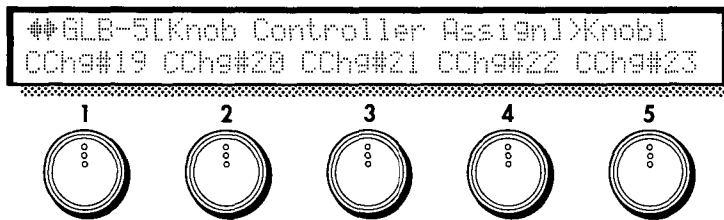

1 Knob1 [OFF, PBender (+/-, +, -), ATouch, CChg#00...95]

2 Knob2 [OFF, PBender (+/-, +, -), ATouch, CChg#00...95]

3 Knob3 [OFF, PBender (+/-, +, -), ATouch, CChg#00...95]

4 Knob4 [OFF, PBender (+/-, +, -), ATouch, CChg#00...95]

5 Knob5 [OFF, PBender (+/-, +, -), ATouch, CChg#00...95]

Select the knob (1~5) to which you want to assign a controller function.

For the knob selected by Knob Number, specify one of 99 controller functions for that knob to perform. (Refer to 6.3 Modulation Source List.)

GLB-6 [Arpeggio Controller]

Select the controller that will modify the velocity and gate time of the arpeggio notes.

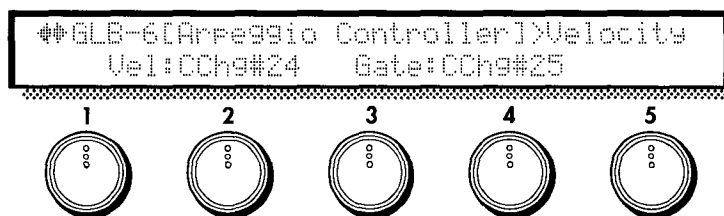

2 Velocity [OFF, PBender, ATouch, CChg#00...95]

Select the controller that will modify the velocity of the arpeggio notes when an arpeggio is being played.

The depth and direction of the change is specified for each pattern in Pattern Define mode page 2 [Velocity Param] Ctrl Intensity.

4 Gate [OFF, PBender, ATouch, CChg#00...95]

Select the controller that will modify the gate time of the arpeggio notes when an arpeggio is being played. The depth and direction of the change is specified for each pattern in Pattern Define mode page 3 [Gate Param] Ctrl Intensity.

GLB-7 [EC5 Function]

When an optional EC5 is connected, these parameters specify the function that is assigned to each pedal.

For details on connections, refer to the Players/Basic Guide section "2.1 Setup".

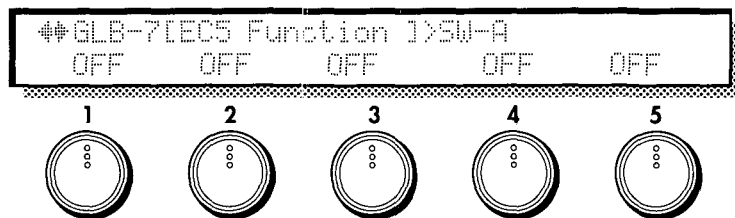

1	SW-A	(Switch A)	[OFF...Wh3Hold]
2	SW-B	(Switch B)	[OFF...Wh3Hold]
3	SW-C	(Switch C)	[OFF...Wh3Hold]
4	SW-D	(Switch D)	[OFF...Wh3Hold]
5	SW-E	(Switch E)	[OFF...Wh3Hold]

For each pedal, select one of the following 14 functions.

0	Off	No function
1	Sustain OFF/ON (Sustain)	Sustain pedal
2	Program Up (Prog-Up)	Select the next program
3	Program Down (Prg-Dwn)	Select the previous program
4	Octave Up (Oct-Up)	1 octave up
5	Octave Down (Oct-Dwn)	1 octave down
6	Portamento OFF/ON (Portmnt)	Portamento on/off
7	Distortion OFF/ON (Dist-SW)	Distortion on/off
8	Wah OFF/ON (Wah-SW)	Wah on/off
9	Delay OFF/ON (Dly-SW)	Chorus on/off
10	Chorus OFF/ON (Cho-SW)	Delay on/off
11	Reverb OFF/ON (Rev-SW)	Reverb on/off
12	Arpeggio OFF/ON (Arpg-SW)	Arpeggiator function on/off
13	Wheel 3 Hold OFF/ON (Wh3Hold)	Wheel 3 Hold on/off

GLB-8 [MIDI]

These parameters are MIDI-related settings.

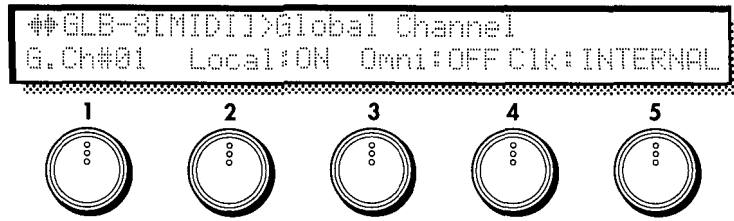

1 Global Channel

[1..16]

This sets the Global MIDI channel.

When musical data or program changes etc. are transmitted from the Prophecy via MIDI, or when transmitting/receiving System Exclusive messages, the Global MIDI Channel of the Prophecy must be set to match the channel of the other MIDI instrument.

2 Local

(Local Control)

[ON, OFF]

When this parameter is set OFF, the keyboard/controller section of the Prophecy will be disconnected from the tone generator. However the keyboard/controller section will continue to transmit data from MIDI OUT.

When using a sequencer etc. to play the Prophecy, turn this parameter OFF to prevent the unintended dual triggering that would be caused by the "echo back" from the sequencer (i.e., a situation in which note messages sent by the Prophecy to the sequencer are retransmitted back to the Prophecy). For normal use, leave this parameter ON.

3 Omni

[ON, OFF]

When this parameter is set OFF, MIDI transmission and reception will take place on the channel specified by the Global Channel setting.

When this parameter is turned ON, transmission will take place on the Global Channel, but reception will take place on any channel, regardless of the Global Channel setting.

5 Clock Source

[INTERNAL, EXTERNAL]

When synchronizing other MIDI devices (external sequencers, drum machines, etc.) to the arpeggio of the Prophecy (i.e., when the Prophecy is the master), set the Clock Source to INTERNAL. This will cause the Prophecy's arpeggiator to operate with its own clock, and it will transmit MIDI Clock messages at the tempo specified by the arpeggio Speed setting.

When synchronizing the arpeggiator of the Prophecy to an external MIDI device, set the Clock Source to EXTERNAL. This will cause the arpeggiator tempo to be controlled by MIDI Clock messages received from the external device.

GLB-9 [MIDI Pitch Bend]

These parameters specify how Pitch Bend messages are transmitted and received, and whether or not incoming Pitch Bend messages are converted before being passed to the tone generator of the Prophecy.

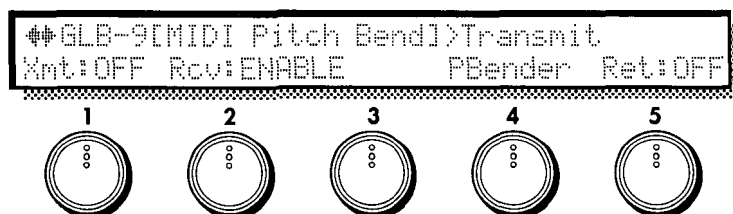

1 Transmit (Message Transmit)

[OFF, ON]

Specify whether or not Pitch Bend messages from the Prophecy will be transmitted from MIDI OUT. With a setting of ON, Pitch Bend messages will be transmitted from MIDI OUT. With a setting of OFF they will not be transmitted.

2 Receive

[DISABLE, ENABLE, INTERPOLE]

Specify whether or not Pitch Bend messages from an external MIDI device will be received. With a setting of ENABLE, Pitch Bend messages from an external device will be received, and with a setting of DISABLE they will be ignored. When INTERPOLE is selected, interpolation will be performed between the Pitch Bend values that are received, creating a smoother change.

4 Translation

[P.Bend, After Touch, C.Chg#00...#95]

This parameter allows incoming Pitch Bend messages to be converted into Aftertouch or a Control Change message.

With a setting of P.Bend, incoming Pitch Bend messages will remain unchanged. With a setting of After Touch they will be converted to Aftertouch data, and with a setting of C.Chg#00...#95 they will be converted into the respective Control Change message.

5 Return

[OFF, ON]

This parameter determines whether or not Pitch Bend messages from the Prophecy's pitch bender will be sent to the tone generator section after being converted by Translation. With a setting of ON they will be sent, and with a setting of OFF they will not be sent.

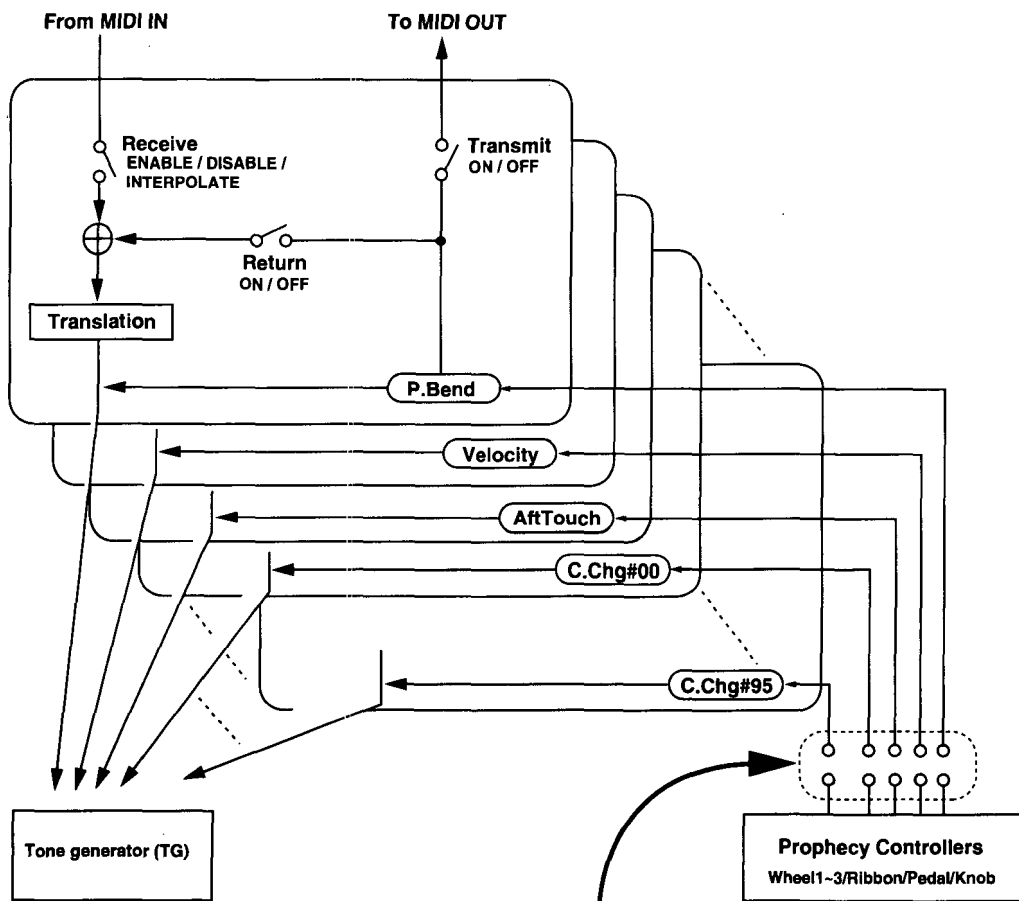

The relation between the Prophecy's controllers and the MIDI messages that the Prophecy transmits and receives is determined by the various controller assign parameters (CMN-5-8, GLB-5).

GLB-10 [MIDI After Touch]

These parameters specify how Aftertouch messages are transmitted and received, and how incoming Aftertouch messages are converted before being passed to the tone generator of the Prophecy.

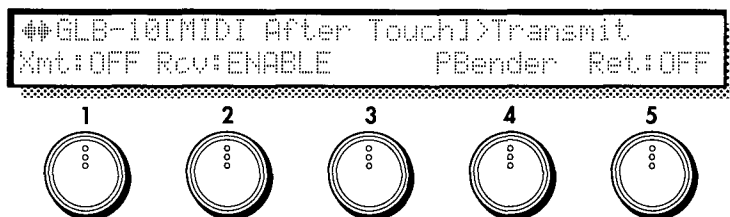

1 Transmit (Message Transmit) **[OFF, ON]**

Specify whether or not Aftertouch messages from the Prophecy will be transmitted from MIDI OUT. With a setting of ON, Aftertouch messages will be transmitted from MIDI OUT. With a setting of OFF they will not be transmitted.

2 Receive **[DISABLE, ENABLE, INTERPOLE]**

Specify whether or not Aftertouch messages from an external MIDI device will be received. With a setting of ENABLE, Aftertouch messages from an external device will be received, and with a setting of DISABLE they will be ignored. When INTERPOLE is selected, interpolation will be performed between the Aftertouch values that are received, creating a smoother change.

4 Translation **[P.Bend, After Touch, C.Chg#00...#95]**

This parameter allows incoming Aftertouch messages to be converted into Pitch Bend or Control Change messages. With a setting of After Touch, incoming Aftertouch messages will remain unchanged. With a setting of P.Bend they will be converted to Pitch Bend data, and with a setting of C.Chg#00...#95 they will be converted into the respective Control Change message.

5 Return **[OFF, ON]**

This parameter determines whether or not Aftertouch messages from the Prophecy's keyboard will be sent to the tone generator section after being converted by Translation. With a setting of ON they will be sent, and with a setting of OFF they will not be sent.

Refer to the diagram on p.140.

GLB-11 [MIDI Control Change]

These parameters specify how specific Control Change messages are transmitted and received, and how incoming Control Change messages are converted before being passed to the tone generator of the Prophecy.

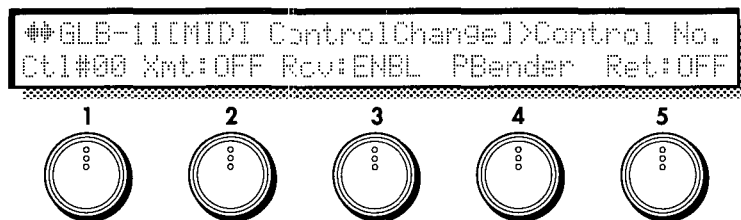

1 Control No (Control Number) [0...95]

Select the Control Change number for which you wish to make settings.

2 Transmit (Message Transmit) [OFF, ON]

Specify whether or not the Control Change message specified by Control Number will be transmitted by the Prophecy from MIDI OUT.

With a setting of ON, Control Change messages of the specified number will be transmitted from MIDI OUT. With a setting of OFF they will not be transmitted.

3 Receive [DSBL, ENBL, INTP]

Specify whether or not Control Change messages of the specified number will be received from an external MIDI device. With a setting of ENBL, Control Change messages of the specified number from an external device will be received, and with a setting of DSBL they will be ignored. When INTP is selected, interpolation will be performed between the data that is received, creating a smoother change.

4 Translation [P.Bend, After Touch, C.Chg#00...#95]

This parameter allows incoming Control Change messages of the specified control number to be converted into another type of message (Pitch Bend, Aftertouch, or a Control Change message of another number).

Incoming Control Change messages of the specified number will be converted into the type of data that you specify here.

5 Return [OFF, ON]

This parameter determines whether or not Control Change messages from the Prophecy's pitch bender will be sent to the tone generator section after being converted by Translation.

With a setting of ON they will be sent, and with a setting of OFF they will not be sent.

Refer to the diagram on p.140.

GLB-12 [MIDI Program Change]

These parameters determine whether or not Program Change messages will be transmitted and received by the Prophecy.

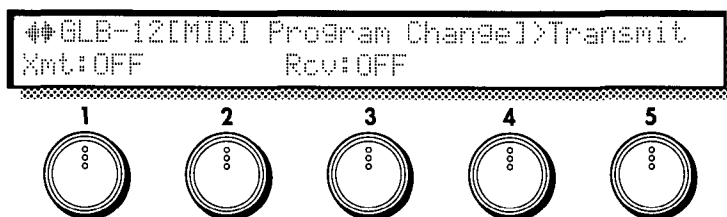

1 Transmit [OFF, ON]

Specify whether or not MIDI Program Change messages will be transmitted from the Prophecy. With a setting of OFF they will not be transmitted, and with a setting of ON they will be transmitted. If this is ON, selecting a program on the Prophecy will cause a Program Change message to be transmitted on the Global MIDI channel (page GLB-8 Global Channel).

3 Receive [OFF, ON]

Specify whether or not MIDI Program Change messages will be received by the Prophecy. With a setting of OFF they will not be received, and with a setting of ON they will be received. If this is ON and the Omni setting (page GLB-8 Omni) is OFF, an incoming Program Change message whose channel matches the Global MIDI channel will change the program of the Prophecy. If Omni is ON, messages of any channel will change the program.

GLB-13 [Prog Bank Select Map]

Here you can specify the MIDI Bank Select messages that will correspond to program banks A, B, and C.



1 Bank [A, B, C]

Select the program bank of the Prophecy for which you wish to specify a Bank Select number.

2 LSB [---, 000...127]

Specify the LSB of the MIDI Bank Select message that will correspond to the above-selected program bank of the Prophecy.

3 MSB [---, 000...127]

Specify the MSB of the MIDI Bank Select message that will correspond to the above-selected program bank of the Prophecy.

GLB-14 [Prog No. Select Map]

These parameters specify how the Prophecy's program numbers will correspond to the number of the Program Change message that is transmitted or received.

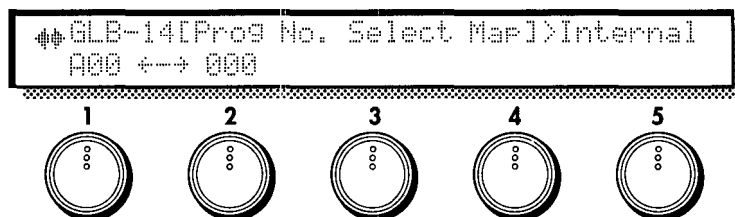

1 Internal (Internal Prog#) **[A00...C63]**

Select a Prophecy program number.

2 External (External Prog#) **[0...127]**

Specify the number of the Program Change message that will correspond to the above-selected program of the Prophecy.

GLB-15 [SysEX Filter]

These parameters determine how System Exclusive messages are transmitted and received.

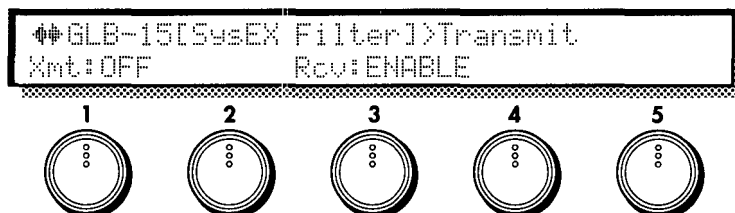

1 Transmit **[OFF,ON]**

With a setting of ON, System Exclusive messages will be transmitted when you edit parameters on the Prophecy. With a setting of OFF, they will not be transmitted. Normally you will leave this OFF. When using an external device such as a computer to edit the parameters of the Prophecy and you want data to be transmitted, turn this ON.

3 Receive **[DISABLE,ENABLE]**

With a setting of ENABLE, System Exclusive data sent from an external device such as a computer will be received. With a setting of DISABLE, it will be ignored. Normally you will leave this at DISABLE. When using an external device such as a computer to edit the Prophecy, turn this to ENABLE.

GLB-16 [Load from Card]

Here you can load Program, Arpeggio Pattern, or Global data from a data card into Internal Program, Internal Pattern, or Global memory.

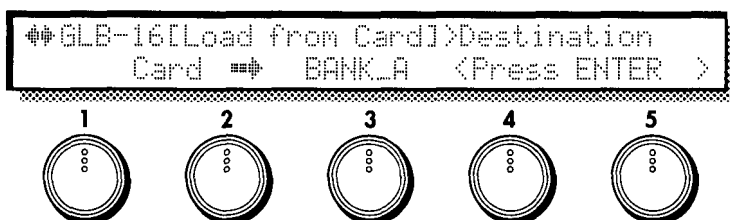

3 Distination

[Bank_A...BANK_B&PAT]

- BANK_A Load all Program data (C00~C63) from card into bank A.
- BANK_B Load all Program data (C00~C63) from card into bank B.
- PAT:UP Load the UP Arpeggio Pattern data from card into UP of the INT PAT bank.
- PAT:DOWN, ALT1, ALT2, RANDOM, PAT1, PAT2, PAT3, PAT4, and PAT5 are the same as PAT:UP.
- ALL_PAT Load all Arpeggio Pattern data (UP~PAT5) from card into the INT PAT bank.
- GLOBAL Load Global data from card into internal memory.
- BANK_A&PAT Load all Program data (C00~63) and all Arpeggio Pattern data (UP~PAT5) from card into bank A and the PAT INT bank.
- BANK_B&PAT Load all Program data (C00~63) and all Arpeggio Pattern data (UP~PAT5) from card into bank B and the PAT INT bank.

- ⚠ Be aware that when you execute loading, the data in the loading destination will be overwritten by the data from the card.
- ⚠ It is not possible to load programs or patterns if memory protect is ON for Program and Arpeggio Pattern (refer to GLB-20). However, Global data can be loaded regardless of the setting.

Procedure for loading from card

- 1) Insert the card. Be sure that the power is OFF when you insert a card.
- 2) Specify the loading source and the loading destination.
- 3) Press the ENTER key. A message of <Are you sure?> will appear. If the internal memory protect is ON, a message of <Mem Protected> will appear. If a card is not inserted, a message of <No Card>, or if there is a problem with the contents of the card, a message of <Illegal Format> will appear, and the operation will be halted.
- 4) If you are sure that your settings are correct, press the ENTER key once again. To cancel the procedure press the EXIT key. When loading is completed, the display will indicate <Completed>. If a message of <Card Trouble > appears, check the card.

GLB-17 [Save to Card]

Here you can save Program, Pattern, or Global data from internal memory to a data card.

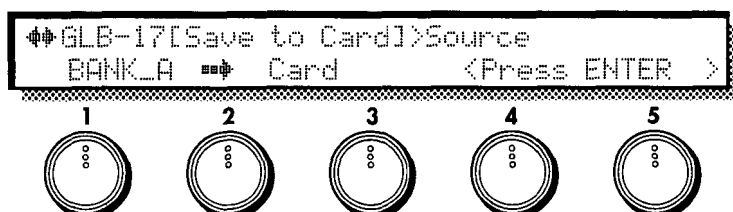

1 Source

[Bank_A...BANK_B&PAT]

- BANK_A** Save all Program data of bank A (A00~A63) into the card.
BANK_B Save all Program data of bank B (B00~B63) into the card.
PAT:UP Save the UP Arpeggio Pattern data from the INT PAT bank into the card.
PAT:DOWN, ALT1, ALT2, RANDOM, PAT1, PAT2, PAT3, PAT4, and PAT5 are the same as PAT:UP.
ALL_PAT Save all INT PAT Arpeggio Pattern data (UP~PAT5) into the card.
GLOBAL Save Global data from internal memory into the card.
BANK_A&PAT Save all bank A Program data (A00~63) and all INT PAT Arpeggio Pattern data (UP~PAT5) into the card.
BANK_B&PAT Save all bank B Program data (B00~63) and all INT PAT Arpeggio Pattern data (UP~PAT5) into the card.



Be aware that when you execute saving, the data in the card will be overwritten by the data from internal memory.

Procedure for saving to card

- 1) Insert the card (SRC-512 memory card; optional). Be sure that the power is OFF when you insert a card. Set the write protect switch of the card to the OFF position.
- 2) Specify the type of data to be loaded.
- 3) Press the ENTER key. A message of <Are you sure?> will appear. If there is a problem with the format of the card, a message of <Format & Write?> will appear. Be aware that if you continue with the Save operation, the card will be initialized.
If the card is not inserted correctly the display will indicate <No Card >, or if the write protect switch is ON the display will indicate <Write Protect>, and the operation will be halted.
- 4) If you are sure that your settings are correct, press the ENTER key once again. To cancel the procedure press the EXIT key. When loading is completed, the display will indicate <Completed>. If a message of <Card Trouble > appears, check the card.

GLB-18 [MIDI DataDump]

This command allows you to transmit various types of data from the Prophecy (programs, arpeggiator patterns, etc.) to an external MIDI device connected to MIDI OUT (a MIDI data filter, computer, or another Prophecy) using System Exclusive messages.

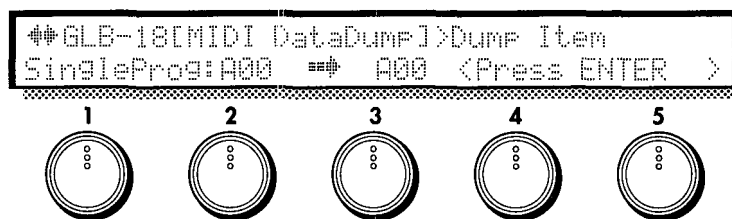

1 Dump Item

[SingleProg...All Data]

Select the data that you wish to transmit.

2 Dump Source

[A00...B63]/[A, B]

If Dump Item has been set to SingleProg or SingleBank, select the program or bank to be transmitted.

3 Destination

[A00...B63]/[A, B]

If Dump Item has been set to SingleProg or SingleBank, select the destination program or bank.

Dump Item	Dump Source	Destination	Description
SingleProg	A00 ~ B63	A00 ~ B63	The program parameters of the specified single program will be transmitted.
SingleBank	A, B	A, B	The program parameters of all programs in the specified bank A or B (64 programs) will be transmitted.
AllProgram	-	-	The program parameters of all programs in banks A and B (128 programs) will be transmitted.
AllPattern	-	-	All arpeggiator patterns of INT PAT (10 patterns) will be transmitted.
GLOBAL	-	-	Global parameters will be transmitted.
All Data	-	-	All Program, All Pattern, and Global data will be transmitted.

Transmitting data

- 1) Connect the MIDI OUT of the Prophecy to the MIDI IN of a device that is able to receive MIDI data dumps. If you are transmitting to a MIDI data filer, there is normally no need to make matching MIDI channel settings. If you are transmitting to another Prophecy, and wish to overwrite the program and pattern data of the receiving unit, set both the transmitting and the receiving unit to the same Global MIDI Channel setting.



Depending on the capacity of your data filer, you may not be able to transmit All Program or All Data. In this case, transmit the data in units of a bank or an individual program.

- 2) Select the type of data that you wish to dump.
- 3) Specify the dump destination.
- 4) Press the ENTER key to execute dumping.
When transmission is complete, the display will indicate <Completed>. Press the EXIT key to return to the normal display.

While a data dump is in progress, do not operate any of the Prophecy's switches.

The following table shows the data size of each type of dump, and the time required for dumping.

Type of data to dump	Data size	Time required (seconds)
SingleProg	621bytes	about 0.4
SingleBank	39141bytes	about 13
AllProgram	78272bytes	about 25.2
AllPattern	1471bytes	about 1
GLOBAL	663bytes	about 0.5
All_Data	80390bytes	about 26.1

Receiving data

- 1) Connect the MIDI OUT of the external device to the MIDI IN of the Prophecy.
- 2) Turn off the Protect setting of program and pattern memory. (Refer to GLB-14, [Memory Protect].)
- 3) Set the System Exclusive Receive setting to ENABLE (refer to GLB-15 "SysEX Filter").
- 4) Set the channel of the transmitting unit to match the Global MIDI Channel of the Prophecy (if you are using a data filer, the Global MIDI Channel that was selected when you saved the data), and transmit the data from the external MIDI device.

The data dump format is given on p.161 "MIDI Implementation".

GLB-19 [Load FactoryData]

Here you can load the preset data (factory settings) from internal ROM.

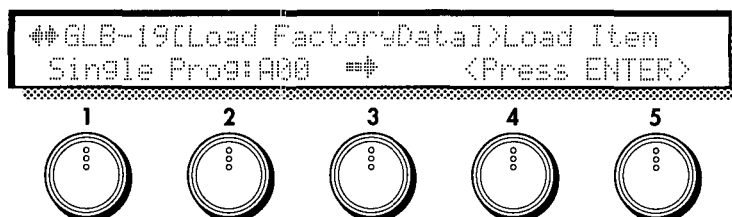

1 Load Item [SingleProg...All Data]

Select the type of preset data (factory settings) that will be loaded from internal ROM.

2 Load Source [A00...B63]/[A, B]

If you have selected SingleProg or SingleBank for Load Item, select the preset data program or bank.

3 Destination [A00...B63]/[A, B]

If you have selected SingleProg or SingleBank for Load Item, specify the loading destination program or bank.

Dump Item	Dump Source	Destination	Description
SingleProg	A00 ~ B63	A00 ~ B63	The specified program will be loaded into the specified bank and program number.
SingleBank	A, B	A, B	All 64 programs of the specified bank will be loaded into the specified destination bank.
AllProgram	-	-	All 128 programs of banks A and B will be loaded.
AllPattern	-	-	All 10 patterns of the INT PAT bank will be loaded.
GLOBAL	-	-	Global parameters (GLB-1~22) will be loaded.
All Data	-	-	All Program, All Pattern, and Global data will be loaded.

GLB-20 [Memory Protect]

Here you can specify whether internal program and pattern memory will be memory protected (write prohibited).

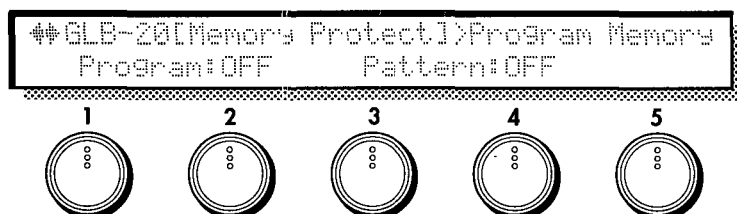

2 Program Memory [OFF, ON]

If this is ON, writing to internal program memory will be prohibited.

When you wish to write edited data, to load preset data, or to receive dump data, turn this OFF.

4 Pattern Memory

[OFF, ON]

If this is ON, writing to internal pattern memory will be prohibited.

When you wish to write edited data, to load preset data, or to receive dump data, turn this OFF.

GLB-21 [Page Memory & 10's Hold]

Here you can specify whether or not to use the Page Memory function and the 10's Hold function.

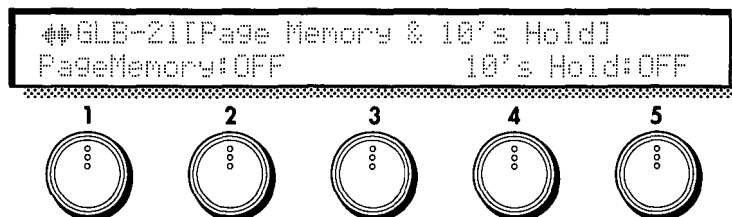

2 Page Memory

[OFF, ON]

If this is ON, the program (bank and number, etc.) that was last-selected when the power was turned off will be selected when you turn the power on. Also when you move to each section of other modes, the page (parameter) last-selected in that section will be selected.

If this is OFF, program A00 will be selected when you turn the power on, and when you move to each mode and section, page 1 will be selected.

In either case, as long as the power remains on, the last-selected page (parameter) in each mode or section will always be selected when you return to that mode or section.

5 10's Hold Memory

[OFF, ON]

When this is ON, if you press a single numeric key and then the ENTER key, the 10's place of the previously-selected program number will be held, and the 1's place will be entered by the numeric key you pressed.

When this is OFF, the 10's place will be fixed at 0, and the numeric key will enter a one-digit number.

GLB-22 [Controller Calibration]

Here you can adjust the effective ranges of the wheel 1--3, ribbon controller, aftertouch, and foot pedal.

Make adjustments here if the specified effect no longer occurs when each controller is moved to the upper or lower limit of its range, or if the effect reaches maximum or minimum mid-way through its range. Also be sure to perform these adjustments after you initialize the Prophecy.

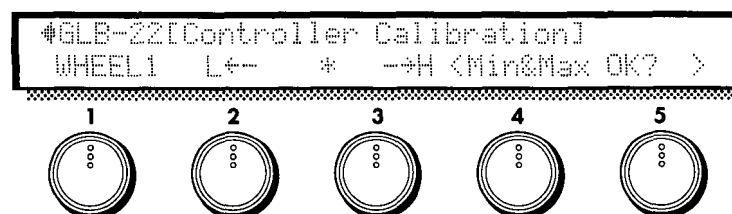

Adjust the active range of each controller. For Wheel 1 and Wheel 3, also adjust the width of the "dead" area in the center.

- WHEEL1: Adjust the active range front ⇔ back, and the width of the center area.
 WHEEL2: Adjust the active range front ⇔ back.
 WHEEL3: Adjust the active range front ⇔ back, and the width of the center area.
 RIBBON_X: Adjust the active range left ⇔ right(X).
 RIBBON_Z: Adjust the active range when the ribbon is pressed.
 AftTouch: Adjust the active range when the keyboard of the Prophecy is pressed.
 Foot_Pdl: Adjust the active range when a connected foot pedal is pressed.

Adjustment procedure

- 1) Select the controller whose active range you wish to adjust.
- 2) Move the selected controller as far as it will go. The display will show several (6--8) asterisks "**".
- 3) Press the ENTER key. A message will ask <Are you sure?>
- 4) If you are satisfied with the settings, press the ENTER key once again. If you wish to cancel, press the EXIT key, and re-do the procedure from step 2.

If a controller other than Wheel 1 or Wheel 3 was selected in step 1, the display will indicate <Completed>, and the response of the controller will be adjusted so that the maximum and minimum effect is reached in the area that you specified. If Wheel 1 or Wheel 3 was selected, the display will ask <Center OK? >. Continue the procedure from step 5.

If the settings were not appropriate, the display will indicate <Value Mismatch>. Press the EXIT key and re-try the procedure from step 2.

Adjusting the center range for Wheels 1 and 3

- 5) For normal settings, move the wheel slightly in the "dead" area. One or two asterisks "*" will appear in the display.
- 6) If an "*" appears in an unwanted position, press the EXIT key and try again from step 5.
- 7) Press the ENTER key. The display will ask <Are you sure?>.
- 8) If you are satisfied with the setting, press the ENTER key once again. If you wish to cancel, press the EXIT key and try again from step 2.

! A small amount of dead area will automatically be inserted at the maximum, minimum and center of the active area as appropriate for each controller. If you make excessively narrow settings for the active area, or if the maximum or minimum positions are too close to the center, the display will indicate <Value Mismatch>.

Example: adjusting Wheel 1

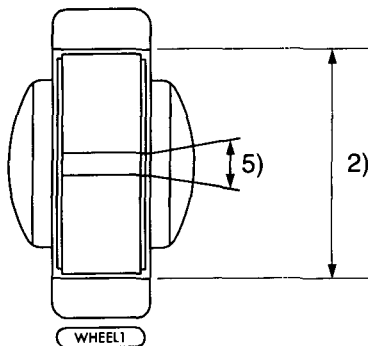

5. WRITE

This chapter explains how to write program settings into memory. You can enter Program Write from any mode by pressing the WRITE key. In Performance mode, you can use Write to save programs you modified using the Performance Editor, or settings for the PE1-4 keys or Portamento on/off, etc. In Edit mode, you can use Write to save the changes you make to parameters other than Global section parameters.

Write

This operation writes a program into memory.



Programs can be saved in bank A 00~63, bank B 00~63, and if a card is writable, into CARD bank 00~63.

The following settings are written into memory:

Performance mode: PE key on/off, knob 1~5 levels, PORTAMENTO key on/off

Edit mode: Parameters other than Global mode; all parameters in Performance Editor Define.

In Edit mode, changes you make to Global section parameters are saved when you change the setting, so there is no need to use the Write procedure.

Pattern Define: 10 arpeggio patterns can be saved in bank INT PAT, but in the same way as for the Global section, the data is saved when you modify it, and there is no need to use the Write procedure.

Memory protect

In order to prevent data from inadvertently being overwritten and lost, a memory protect switch is provided in Global section page GLB-20 [Memory Protect]. If you wish to write data into memory, you must first turn off this memory protect setting in the Global section.

Rename

If you want to assign a new name to an edited program, specify the name in Common section page CMN-1 [Program Name]. You can specify a program category in page CMN-2 [Prog Category], and when selecting programs in Performance mode you can use the PAGE keys to select programs by category.

For details on these procedures, refer to the separate Players/Basic Guide.

6.

Appendix

- 6.1 About data cards
- 6.2 About modulation sources
- 6.3 Modulation source List
- 6.4 Performance Editor Assign Parameter List
- 6.5 LFO Wave List
- 6.6 MIDI Implementation
- 6.7 Troubleshooting
- 6.8 Error messages
- 6.9 Other messages

6.1 About data cards

A data card can be inserted into the Prophecy to add programs or arpeggio patterns, or to store your own original programs or arpeggio patterns.

A RAM card (SRC-512: sold separately) can store programs, arpeggio patterns, and global data that you have edited. Programs in a RAM card can be edited and written back into the card.

A ROM card (sold separately) also stores programs and arpeggio patterns, but unlike a RAM card, cannot store data that you have edited. Also, it is not possible to directly edit the data in a ROM card, so it must first be copied into internal memory before it can be edited.

Data card handling

Insert the card into the card slot with the card label facing upward.

 Be sure that the power is turned OFF before inserting or removing a card. Inserting or removing a card while the Prophecy is producing sound or while an operation is being performed may cause malfunctions.

RAM card write protect switch

RAM cards have a Write Protect switch that allows you to keep data from being accidentally being erased or overwritten. When this switch is ON, it is not possible to write data into the RAM card. (The Write Protect switch is located on the side of the RAM card.)

When you need to write data into the RAM card, set the Write Protect switch to the OFF position. However when the switch is in the OFF position, the battery will run down faster, so leave it in the ON position when the card is not being used.

Formatting a RAM card

When you use the Edit mode Global section page GLB-17 [Save to Card] command to save data to a new RAM card, the card will automatically be formatted. (There is no need for you to format the card.)

If you wish to write individual programs or arpeggio patterns into a RAM card, you must first use page GLB-17 [Save to Card] to save data and thereby format the card.

RAM card battery

RAM cards contain a battery (CR2016 lithium battery) that preserves the data. If the battery voltage becomes low, the display will indicate "Battery Low". To replace the battery, refer to the instructions included with the RAM card.

Replacing the RAM card battery

In order to prevent loss of data stored in a RAM card, we recommend that you replace the battery once a year. If you store the card in a location of high temperature (above 40 degrees C) the battery will run down faster. Replace the battery with a CR2016 lithium battery. (Contact a nearby musical instrument dealer.)

If you simply remove the battery from the card when replacing the battery, the data in the card will be lost. If you wish to preserve the data that is in the card, insert the card into the Prophecy and replace the battery with the Prophecy's power turned ON.

6.2 About modulation sources

Sources of control such as an LFO, the pitch bender, or keyboard velocity can be assigned to control the parameters of the oscillator, the filter, and the effects (e.g., Filter Cutoff, or Effect Balance, etc.) Sources of control that can be used to control ("modulate") parameters are known as Modulation Sources. For each parameter that can be controlled by a modulation source, there is a Mod.Source setting that allows you to select one of the 111 types of modulation sources (refer to 6.3 Modulation Source List) to control that parameter.

* How keyboard velocity acts as a Modulation Source

Velocity can act as a modulation source in two ways.

- 1 If velocity is selected as a modulation source, the change will be centered around the setting of the parameter that is being controlled. (See figure 1.)
- 2 If the Velocity Control amount can be dedicated to a specific parameter, positive (+) settings will result in the control parameter value being reached for maximum velocities, and negative (-) settings will result in the control parameter value being reached for minimum velocities. (See figure 2.)

(Figure 1)
Amount of parameter change

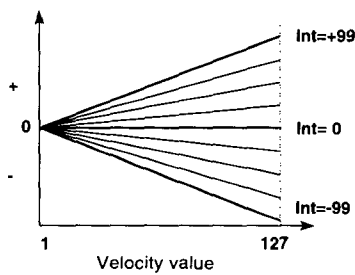

(Figure 2)
Amount of parameter change

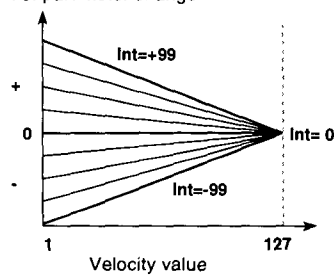

6.3 Modulation Source List

No	Modulation Source	Editor Name
0	Off	Off
1	EG1	EG1
2	EG2	EG2
3	EG3	EG3
4	EG4	EG4
5	Pitch EG	PitchEG
6	Amp EG	AmpEG
7	LFO1	LFO1
8	LFO2	LFO2
9	LFO3	LFO3
10	LFO4	LFO4
11	Portamento	Portmnt
12	Note No.	NoteNo.
13	Velocity	Veloc
14	Pitch Bender	PBender
15	After Touch	ATouch
16	Control Change #0	CChg#00
.	.	.
.	.	.
.	.	.
111	Control Change #95	CChg#95

6.4 Performance Editor Assign Parameter List

No.	Assign Parameter Name	Editor List Name	Display Name	Value Range
0	NULL	-----OFF-----	--OFF--	
<OSC section>				
[OSC common]				
(Pitch EG)				
1	Start Level	PEG_StartLevel	PEGSttL	(-99...+99)
2	Attack Time	PEG_AttackTime	PEGAtkT	(0...99)
3	Attack Level	PEG_AttackLevel	PEGAtkL	(-99...+99)
4	Decay Time	PEG_DecayTime	PEGDcyT	(0...99)
5	Break Level	PEG_BreakLevel	PEGBrkL	(-99...+99)
6	Slope Time	PEG_SlopeTime	PEGSlpT	(0...99)
7	Release Time	PEG_ReleaseTime	PEGRlsT	(0...99)
8	Release Level	PEG_ReleasLevel	PEGRlsL	(-99...+99)
(Portamento)				
9	Fingered mode	PortaFingerMode	PrtMode	(NORMAL/FINGERED=0...1)
10	Portamento Time	PortamentoTime	PrtTime	(0...99)
11	PortamentoTimeVelocityControl	PortaTimeVel	PrtTVel	(-99...+99)
[OSC1]				
(Basic Pitch)				
12	Octave	OSC1_Octave	OSC1Oct	(32"...4" = 0...3)
13	Semi Tone	OSC1_SemiTone	OSC1Sem	(-12...+12)
14	Fine Tune	OSC1_FineTune	OSC1Fin	(-50...+50Hz)
15	Frequency Offset	OSC1_FreqOffset	OSC1FOf	(-10.0...+10.0Hz)
(Pitch Mod)				
16	Pitch Mod.LFO Intensity	OSC1PitchLFOInt	O1PLFOI	(-99...+99)
17	Pitch Mod.Intensity	OSC1PitchModInt	O1PModI	(-99...+99)
[OSC2]				
(Basic Pitch)				
18	Octave	OSC2_Octave	OSC2Oct	(32"...4" = 0...3)
19	Semi Tone	OSC2_SemiTone	OSC2Sem	(-12...+12)
20	Fine Tune	OSC2_FineTune	OSC2Fin	(-50...+50Hz)
21	Frequency Offset	OSC2_FreqOffset	OSC2FOf	(-10.0...+10.0Hz)
(Pitch Mod)				
22	Pitch Mod.LFO Intensity	OSC2PitchLFOInt	O2PLFOI	(-99...+99)
23	Pitch Mod.Intensity	OSC2PitchModInt	O2PModI	(-99...+99)
[Sub OSC]				
24	Relative Semi Tone	SUBOSC_SemiTone	SubOSem	(-24...+24)
25	Relative Fine Tune	SUBOSC_FineTune	SubOFin	(-50...+50)
26	Wave Form	SUBOSC_Wave	SubOWav	(SIN/SAW/TRI/SQU=0...3)
[Noise Generator]				
27	Noise LPF Frequency	Noise_LPF_Fc	NoizLPF	(0...99)
<FILTER section>				
[Filter 1]				
28	Cutoff Frequency	Filter1_Fc	F1Fc	(0...99)
29	Cutoff Frequency Mod.EG Intensity	Filter1FcEGInt	F1FcEGI	(-99...+99)
30	Cutoff Frequency Mod.LFO Intensity	Filter1FcLFOInt	F1FcLFI	(-99...+99)
31	Cutoff Frequency Mod.Intensity	Filter1FcModInt	F1FcMdl	(-99...+99)
32	Resonance	Filt1_Resonance	F1Reso	(0...99)
33	Resonance Mod.Intensity	Filt1ResoModInt	F1RsMdl	(-99...+99)

[Filter2]

34	Cutoff Frequency	Filter2_Fc	F2Fc	(0...99)
35	Cutoff Frequency Mod. EG Intensity	Filter2FcEGInt	F2FcEGl	(-99...+99)
36	Cutoff Frequency Mod. LFO Intensity	Filter2FcLFOInt	F2FcLFl	(-99...+99)
37	Cutoff Frequency Mod. Intensity	Filter2FcModInt	F2FcMdl	(-99...+99)
38	Resonance	Filt2_Resonance	F2Reso	(0...99)
39	Resonance Mod. Intensity	Filt2ResoModInt	F2RsMdl	(-99...+99)

<AMP section>**[AMP1]**

40	Amplitude	Amp1_Amplitude	Amp1	(0...99)
41	Amplitude Mod. Intensity	Amp1_ModInt	Amp1Mdl	(-99...+99)

[AMP2]

42	Amplitude	Amp2_Amplitude	Amp2	(0...99)
43	Amplitude Mod. Intensity	Amp2_ModInt	Amp2Mdl	(-99...+99)

[Amp EG]**(Amplitude EG)**

44	Start Level	AEG_StartLevel	AEGStL	(0...99)
45	Attack Time	AEG_AttackTime	AEGAtkT	(0...99)
46	Attack Level	AEG_AttackLevel	AEGAtkL	(0...99)
47	Decay Time	AEG_DecayTime	AEGDcyT	(0...99)
48	Break Level	AEG_BreakLevel	AEGBrkL	(0...99)
49	Slope Time	AEG_SlopeTime	AEGSlpT	(0...99)
50	Sustain Level	AEG_SustanLevel	AEGSusL	(0...99)
51	Release Time	AEG_ReleaseTime	AEGRIst	(0...99)

(Amplitude EG Velocity Control)

52	Level	AEG_VelCtlLevel	AEGVelL	(-99...+99)
53	Attack Time	AEG_VelAtckTime	AEGVAiT	(-99...+99)
54	Decay Time	AEG_VelDcayTime	AEGVDcT	(-99...+99)
55	Slope Time	AEG_VelSlopTime	AEGVSIT	(-99...+99)
56	Release Time	AEG_VelRIstTime	AEGVRIT	(-99...+99)

< EFFECT section >**[Distortion & Wah]****(Distortion)**

57	Gain	Distortion_Gain	DistGin	(0...99)
58	Tone	Distortion_Tone	DistTon	(0...99)
59	Effect Balance	Distortion_Bal	DistBal	(0...100%)

(Wah)

60	Resonance	Wah_Resonance	WahReso	(0...99)
61	Effect Balance	Wah_Balance	WahBal	(0...100%)

[Delay/Reverb]**(Chorus/Flanger)**

62	Feedback	Chorus_Feedback	ChoFbk	(-99...+99)
63	Depth	Chorus_Depth	ChoDpth	(0...99)
64	Effect Balance	Chorus_Balance	ChoBal	(0...100%)

(Delay)

65	Delay Time	Delay_DelayTime	DlyTime	(0...99)
66	Feedback	Delay_Feedback	DlyFbk	(0...99)
67	High Damp	Delay_HighDamp	DlyHD	(0...99)
68	Effect Balance	Delay_Balance	DlyBal	(0...100%)

(Reverb)

69	Reverb Time	Reverb_Time	RevTime	(0...99)
70	High Damp	Reverb_HighDamp	RevHD	(0...99)
71	Effect Balance	Reverb_Balance	RevBal	(0...100%)

[Panpot & OutputLevel]

72	Panpot	Panpot	Panpot	(LEFT...RIGHT = 0...127)
----	--------	--------	--------	--------------------------

<EG section>

[EG1]

(Envelope)

73	Start Level	EG1_StartLevel	EG1SttL	(-99...+99)
74	Attack Time	EG1_AttackTime	EG1AtkT	(0...99)
75	Attack Level	EG1_AttackLevel	EG1AtkL	(-99...+99)
76	Decay Time	EG1_DecayTime	EG1DcyT	(0...99)
77	Break Level	EG1_BreakLevel	EG1BrkL	(-99...+99)
78	Slope Time	EG1_SlopeTime	EG1SlpT	(0...99)
79	Sustain Level	EG1_SustanLevel	EG1SusL	(-99...+99)
80	Release Time	EG1_ReleaseTime	EG1RlsT	(0...99)
81	Release Level	EG1_ReleasLevel	EG1RlsL	(-99...+99)

(Velocity Control)

82	Level	EG1_VelCtlLevel	EG1VCtL	(-99...+99)
83	Attack Time	EG1_VelAtckTime	EG1VAtT	(-99...+99)
84	Decay Time	EG1_VelDcayTime	EG1VDcT	(-99...+99)
85	Slope Time	EG1_VelSlopTime	EG1VSIT	(-99...+99)
86	Release Time	EG1_VelRlsTime	EG1VRIT	(-99...+99)

[EG2]

(Envelope)

87	Start Level	EG2_StartLevel	EG2SttL	(-99...+99)
88	Attack Time	EG2_AttackTime	EG2AtkT	(0...99)
89	Attack Level	EG2_AttackLevel	EG2AtkL	(-99...+99)
90	Decay Time	EG2_DecayTime	EG2DcyT	(0...99)
91	Break Level	EG2_BreakLevel	EG2BrkL	(-99...+99)
92	Slope Time	EG2_SlopeTime	EG2SlpT	(0...99)
93	Sustain Level	EG2_SustanLevel	EG2SusL	(-99...+99)
94	Release Time	EG2_ReleaseTime	EG2RlsT	(0...99)
95	Release Level	EG2_ReleasLevel	EG2RlsL	(-99...+99)

(Velocity Control)

96	Level	EG2_VelCtlLevel	EG2VCtL	(-99...+99)
97	Attack Time	EG2_VelAtckTime	EG2VAtT	(-99...+99)
98	Decay Time	EG2_VelDcayTime	EG2VDcT	(-99...+99)
99	Slope Time	EG2_VelSlopTime	EG2VSIT	(-99...+99)
100	Release Time	EG2_VelRlsTime	EG2VRIT	(-99...+99)

[EG3]

(Envelope)

101	Start Level	EG3_StartLevel	EG3SttL	(-99...+99)
102	Attack Time	EG3_AttackTime	EG3AtkT	(0...99)
103	Attack Level	EG3_AttackLevel	EG3AtkL	(-99...+99)
104	Decay Time	EG3_DecayTime	EG3DcyT	(0...99)
105	Break Level	EG3_BreakLevel	EG3BrkL	(-99...+99)
106	Slope Time	EG3_SlopeTime	EG3SlpT	(0...99)
107	Sustain Level	EG3_SustanLevel	EG3SusL	(-99...+99)
108	Release Time	EG3_ReleaseTime	EG3RlsT	(0...99)
109	Release Level	EG3_ReleasLevel	EG3RlsL	(-99...+99)

(Velocity Control)

110	Level	EG3_VelCtlLevel	EG3VCtL	(-99...+99)
111	Attack Time	EG3_VelAtckTime	EG3VAtT	(-99...+99)
112	Decay Time	EG3_VelDcayTime	EG3VDcT	(-99...+99)
113	Slope Time	EG3_VelSlopTime	EG3VSIT	(-99...+99)
114	Release Time	EG3_VelRlsTime	EG3VRIT	(-99...+99)

[EG4]

(Envelope)

115	Start Level	EG4_StartLevel	EG4SttL	(-99...+99)
116	Attack Time	EG4_AttackTime	EG4AtkT	(0...99)
117	Attack Level	EG4_AttackLevel	EG4AtkL	(-99...+99)
118	Decay Time	EG4_DecayTime	EG4DcyT	(0...99)
119	Break Level	EG4_BreakLevel	EG4BrkL	(-99...+99)
120	Slope Time	EG4_SlopeTime	EG4SlpT	(0...99)

121	Sustain Level	EG4_SustanLevel	EG4SusL	(-99...+99)
122	Release Time	EG4_ReleaseTime	EG4RIsT	(0...99)
123	Release Level	EG4_ReleasLevel	EG4RIsL	(-99...+99)

(Velocity Control)

124	Level	EG4_VelCtlLevel	EG4VcTL	(-99...+99)
125	Attack Time	EG4_VelAtckTime	EG4VAiT	(-99...+99)
126	Decay Time	EG4_VelDcayTime	EG4VDcT	(-99...+99)
127	Slope Time	EG4_VelSlopTime	EG4VSIT	(-99...+99)
128	Release Time	EG4_VelRIsTime	EG4VRIT	(-99...+99)

<LFO section>**[LFO1]**

129	WaveForm	LFO1_WaveForm	LFO1Wav	(0...29)
130	Frequency	LFO1_Frequency	LFO1Frq	(0...199)
131	Offset	LFO1_AmpOffset	LFO1Ofs	(-99...+99)
132	Amplitude Mod.Intensity	LFO1_AmpModInt	LFO1Amp	(-99...+99)
133	Fade In	LFO1_Fade_In	LFO1Fad	(-99...+99)

[LFO2]

134	WaveForm	LFO2_WaveForm	LFO2Wav	(0...29)
135	Frequency	LFO2_Frequency	LFO2Frq	(0...199)
136	Offset	LFO2_AmpOffset	LFO2Ofs	(-99...+99)
137	Amplitude Mod.Intensity	LFO2_AmpModInt	LFO2Amp	(-99...+99)
138	Fade In	LFO2_Fade_In	LFO2Fad	(-99...+99)

[LFO3]

139	WaveForm	LFO3_WaveForm	LFO3Wav	(0...29)
140	Frequency	LFO3_Frequency	LFO3Frq	(0...199)
141	Offset	LFO3_AmpOffset	LFO3Ofs	(-99...+99)
142	Amplitude Mod.Intensity	LFO3_AmpModInt	LFO3Amp	(-99...+99)
143	Fade In	LFO3_Fade_In	LFO3Fad	(-99...+99)

[LFO4]

144	WaveForm	LFO4_WaveForm	LFO4Wav	(0...29)
145	Frequency	LFO4_Frequency	LFO4Frq	(0...199)
146	Offset	LFO4_AmpOffset	LFO4Ofs	(-99...+99)
147	Amplitude Mod.Intensity	LFO4_AmpModInt	LFO4Amp	(-99...+99)
148	Fade In	LFO4_Fade_In	LFO4Fad	(-99...+99)

<MIXER section>**(OSC1 Mixer Output1)**

149	Level	Mix_OSC1O1Level	MO1Lv1	(0...99)
150	Level Mod.Intensity	MixOSC1O1ModInt	MO1L1MI	(-99...+99)

(OSC1 Mixer Output2)

151	Level	Mix_OSC1O2Level	MO1Lv2	(0...99)
152	Level Mod.Intensity	MixOSC1O2ModInt	MO1L2MI	(-99...+99)

(OSC2 Mixer Output1)

153	Level	Mix_OSC2O1Level	MO2Lv1	(0...99)
154	Level Mod.Intensity	MixOSC2O1ModInt	MO2L1MI	(-99...+99)

(OSC2 Mixer Output2)

155	Level	Mix_OSC2O2Level	MO2Lv2	(0...99)
156	Level Mod.Intensity	MixOSC2O2ModInt	MO2L2MI	(-99...+99)

(Sub OSC Mixer Output1)

157	Level	Mix_Sub_O1Level	MSbLv1	(0...99)
158	Level Mod.Intensity	Mix_SubO1ModInt	MSbL1MI	(-99...+99)

(Sub OSC Mixer Output2)

159	Level	Mix_Sub_O2Level	MSbLv2	(0...99)
160	Level Mod.Intensity	Mix_SubO2ModInt	MSbL2MI	(-99...+99)

(Noise Mixer Output1)

161	Level	Mix_NoI_O1Level	MNsLv1	(0...99)
162	Level Mod.Intensity	Mix_NoI01ModInt	MNsL1MI	(-99...+99)

(Noise Mixer Output2)

163	Level	Mix_NoI_O2Level	MNsLv2	(0...99)
164	Level Mod.Intensity	Mix_NoI02ModInt	MNsL2MI	(-99...+99)

(Feedback Mixer Output1)

165	Level	Mix_Fbk_O1Level	MFbLvl1	(0...99)
166	Level Mod.Intensity	Mix_FbkO1ModInt	MFbL1MI	(-99...+99)

(Feedback Mixer Output2)

167	Level	Mix_Fbk_O2Level	MFbLvl2	(0...99)
168	Level Mod.Intensity	Mix_FbkO2ModInt	MFbL2MI	(-99...+99)

< W.SHAPE section >**[WS1]**

169	Input Gain	WS1_InputGain	W1InG	(0...99)
170	Input Gain Mod.Intensity	WS1InGainModInt	W1InMod	(-99...+99)
171	Shape Table Select	WS1_ShapeTblSel	W1SpTbl	(CLIP/RESO = 0...1)
172	Shape	WS1_Shape	W1Sp	(0...99)
173	Shape Mod.Intensity	WS1_ShapeModInt	W1SpMod	(-99...+99)
174	Output Gain	WS1_OutputGain	W1OutG	(0...99)
175	Thru Gain	WS1_ThruGain	W1ThruG	(0...99)

[WS2]

176	Input Gain	WS2_InputGain	W2InG	(0...99)
177	Input Gain Mod.Intensity	WS2InGainModInt	W2InMod	(-99...+99)
178	Shape Table Select	WS2_ShapeTblSel	W2SpTbl	(CLIP/RESO = 0...1)
179	Shape	WS2_Shape	W2Sp	(0...99)
180	Shape Mod.Intensity	WS2_ShapeModInt	W2SpMod	(-99...+99)
181	Output Gain	WS2_OutputGain	W2OutG	(0...99)
182	Thru Gain	WS2_ThruGain	W2ThruG	(0...99)

<COMMON section>

183	Trigger Mode	TriggerMode	TrgMode	(MULTI/SINGLE/VELOCITY = 0...2)
184	Threshold Velocity	RetrigThresVel	RTrgVel	(1...127)
185	Above/Below	RetrigAbvBelw	RTrgA/B	(ABOVE/BELOW = 0...1)
186	Scale Key	ScaleKey	ScalKey	(C...B = 0...11)
187	Scale Type	ScaleType	ScalTyp	(0...10)
188	Random Pitch Intensity	RandomPitchInt	RNDPInt	(0...99)

<Multi OSC Synth Section >**[STD1]**

189	Wave Select	Std1_Wave	Sd1Wave	(SAW/PULSE = 0...1)
190	Wave Level	Std1_WaveLevel	Sd1WavL	(0...99)
191	Ramp Level	Std1_RampLevel	Sd1RmpL	(0...99)
192	Wave Form	Std1_WaveForm	Sd1WavF	(-99...+99)
193	Wave Form Mod.LFO Intensity	Std1_WaveLFOInt	Sd1LFOI	(-99...+99)
194	wave Form Mod.Intensity	Std1_WaveModInt	Sd1ModI	(-99...+99)

[STD2]

195	Wave Select	Std2_Wave	Sd2Wave	(SAW/PULSE = 0...1)
196	Wave Level	Std2_WaveLevel	Sd2WavL	(0...99)
197	Ramp Level	Std2_RampLevel	Sd2RmpL	(0...99)
198	Wave Form	Std2_WaveForm	Sd2WavF	(-99...+99)
199	Wave Form Mod.LFO Intensity	Std2_WaveLFOInt	Sd2LFOI	(-99...+99)
200	wave Form Mod.Intensity	Std2_WaveModInt	Sd2ModI	(-99...+99)

[COMB1]

201	Noise Level	Comb1_NoiseLvl	Cm1NoiL	(0...99)
202	Input Wave Level	Comb1_InWaveLvl	Cm1InWL	(0...99)
203	Comb Filter Feedback	Comb1_Feedback	Cm1Fbk	(0...99)
204	Feedback Mod.EG Intensity	Comb1_FbkEGInt	Cm1FbEI	(-99...+99)
205	Feedback Mod.Intensity	Comb1_FbkModInt	Cm1FbMI	(-99...+99)
206	Loop LPF Freq	Comb1_LoopLPF	Cm1Loop	(0...99)

[COMB2]

207	Noise Level	Comb2_NoiseLvl	Cm2NoiL	(0...99)
208	Input Wave Level	Comb2_InWaveLvl	Cm2InWL	(0...99)
209	Comb Filter Feedback	Comb2_Feedback	Cm2Fbk	(0...99)
200	Feedback Mod.EG Intensity	Comb2_FbkEGInt	Cm2FbEI	(-99...+99)
211	Feedback Mod.Intensity	Comb2_FbkModInt	Cm2FbMI	(-99...+99)
212	Loop LPF Freq	Comb2_LoopLPF	Cm2Loop	(0...99)
211	Feedback Mod.Intensity	Comb1_FbkMdl	Cm1FbMI	(-99...+99)
212	Loop LPF Freq	Comb1_LoopLP	Cm1Loop	(0...99)

[VPM1]**(Carrier)**

213	Carrier Wave	VPM1Cr_Wave	V1CWav	(SIN/SAW/TRI/SQU = 0...3)
214	Carrier Level	VPM1Cr_Level	V1CLvl	(0...99)
215	Carrier Level Mod. EG Intensity	VPM1Cr_LvlEGInt	V1CLEGI	(-99...+99)
216	Carrier Level Mod. Intensity	VPM1CrLvlModInt	V1CLMdl	(-99...+99)
217	Wave Shape	VPM1_WaveShape	V1WvShp	(0...99)
218	Wave Shape Mod. LFO Intensity	VPM1WavShLFOInt	V1WSLFI	(-99...+99)
219	Wave Shape Mod. Intensity	VPM1WavShModInt	V1WSMdl	(-99...+99)
220	Feedback	VPM1Cr_Feedback	V1CFbk	(0...99)

(modulator)

221	Modulator Pitch Mod. Intensity	VPM1MdPitModInt	V1MPMI	(-99...+99)
222	Modulator Wave	VPM1Md_Wave	V1MWav	(SIN/SAW/TRI/SQU/OSC2=0...4)
223	Modulator Level	VPM1Md_Level	V1MLvl	(0...99)
224	Modulator Level Mod. EG Intensity	VPM1Md_LvlEGInt	V1MLEGI	(-99...+99)
225	Modulator Level Mod. Intensity	VPM1MdLvlModInt	V1MLMdl	(-99...+99)

[VPM2]**(Carrier)**

226	Carrier Wave	VPM2Cr_Wave	V2CWav	(SIN/SAW/TRI/SQU = 0...3)
227	Carrier Level	VPM2Cr_Level	V2CLvl	(0...99)
228	Carrier Level Mod. EG Intensity	VPM2Cr_LvlEGInt	V2CLEGI	(-99...+99)
229	Carrier Level Mod. Intensity	VPM2CrLvlModInt	V2CLMdl	(-99...+99)
230	Wave Shape	VPM2_WaveShape	V2WvShp	(0...99)
231	Wave Shape Mod. LFO Intensity	VPM2WavShLFOInt	V2WSLFI	(-99...+99)
232	Wave Shape Mod. Intensity	VPM2WavShModInt	V2WSMdl	(-99...+99)
233	Feedback	VPM2Cr_Feedback	V2CFbk	(0...99)

(modulator)

234	Modulator Pitch Mod. Intensity	VPM2MdPitModInt	V2MPMI	(-99...+99)
235	Modulator Wave	VPM2Md_Wave	V2MWav	(SIN/SAW/TRI/SQU/OSC1=0...4)
236	Modulator Level	VPM2Md_Level	V2MLvl	(0...99)
237	Modulator Level Mod. EG Intensity	VPM2Md_LvlEGInt	V2MLEGI	(-99...+99)
238	Modulator Level Mod. Intensity	VPM2MdLvlModInt	V2MLMdl	(-99...+99)

[MOD]**(Ring Modulation)**

239	Ring Carrier Select	Mod_RingCarria	MdRgCSI	(SIN/SAW/SQU = 0...2)
-----	---------------------	----------------	---------	-----------------------

(Cross Modulation)

240	Cross Carrier Select	Mod_CrosCarria	MdCsCSI	(SIN/SAW/SQU = 0...2)
241	Cross Modulation Depth	Mod_CrosDepth	MdCsMDp	(0...99)

(Sync Modulation)

242	Sync Slave Wave Select	Mod_SyncWave	MdSyncWv	(SAW/TRI = 0...1)
-----	------------------------	--------------	----------	-------------------

[BRASS]

243	Pressure EG Intensity	BrassPressEGInt	BrsPrEG	(-99...+99)
244	Lip Character	BrassLipCharact	BrsLipC	(0...99)
245	Bell Tone	BrassBellTone	BrsTone	(0...99)
246	Bell Resonance	BrassBellReso	BrsReso	(0...99)
247	Noise Level	BrassNoiseLevel	BrsNoiL	(0...99)

[REED]

248	Pressure EG Intensity	ReedPressEGInt	RedPrEG	(+0...+99)
249	Reed Mod. Intensity	ReedReedModInt	RedModI	(-99...+99)
250	Noise Level	ReedNoiseLevel	RedNoiL	(0...99)

[PLUCK]

251	Attack Noise Level	PluckNoiseLevel	PlkNoiL	(0...99)
252	Attack Noise Filter Fc	PluckNoiseFc	PlkNoiF	(0...99)
253	String Position	PluckStringPosi	PlkStrP	(0...99)
254	String Loss	PluckStringLoss	PlkStrL	(0...99)
255	Inharmonicity Amount	PluckInharmo	Inharmo	(0...99)

6.5 LFO Wave List

00	SIN'0
01	SIN'180
02	COS'0
03	COS'180
04	TRI'0
05	TRI'90
06	TRI'180
07	TRI'270
08	SAWUP'0
09	SAWUP'180
10	SAWDOWN'0
11	SAWDOWN'180
12	SQR'0
13	SQR'180
14~19	RANDOM 1...6
20	Growl
21	GuitarVib
22	Step TRI
23	Step SAW
24	Step TRI4
25	Step SAW6
26	Exp SAW UP
27	Exp SAW DOWN
28	Exp TRI
29	Exp Vib

6.6 MIDI Implementation

1. TRANSMITTED DATA

1-1 CHANNEL MESSAGES [H]:Hex, [D]:Decimal

Status [Hex]	Second [H] [D]	Third [H] [D]	Description
8n	kk (kk)	40 (64)	Note Off
9n	kk (kk)	vv (vv)	Note On vv=1-127
Bn	00 (00)	mm (mm)	Program Bank Select(MSB)
Bn	01 (01)	vv (vv)	Pitch Modulation Depth
Bn	06 (06)	vv (vv)	Data Entry(MSB) *1
Bn	07 (07)	vv (vv)	Volume
Bn	0A (10)	vv (vv)	Panpot
Bn	0B (11)	vv (vv)	Expression
Bn	20 (32)	bb (bb)	Program Bank Select(LSB)
Bn	40 (64)	00/7F (0/127)	Sustain Off/On
Bn	41 (65)	00/7F (0/127)	Portamento Off/On
Bn	5B (91)	vv (vv)	Effect1 Depth (Distortion)
Bn	5C (92)	vv (vv)	Effect1 Depth (Wah)
Bn	5D (93)	vv (vv)	Effect1 Depth (Chorus/Flanger)
Bn	5E (94)	vv (vv)	Effect1 Depth (Delay)
Bn	5F (95)	vv (vv)	Effect1 Depth (Reverb)
Bn	62 (98)	vv (vv)	NRPN LSB *1
Bn	63 (99)	vv (vv)	NRPN MSB *1
Bn	cc (cc)	vv (vv)	Control Change cc=00-95
Cn	pp (pp)	-- --	Program Change
Dn	vv (vv)	-- --	Channel Pressure (After Touch)
En	bb (bb)	bb (bb)	Pitch Bender Change

n : MIDI Channel (0-15)
vv: Value

*1 Non Registered Parameter Number

MSB LSB [H] [H]	Parameter	Data Entry(MSB) Value
00 01	Arpeggio Pattern Select	0C-09: Int. Pat, 0Ah-13h: Card Pat
00 06	PE1 On/Off	00-3F: OFF, 40h-7Fh: ON
00 07	PE2 On/Off	00-3F: OFF, 40h-7Fh: ON
00 08	PE3 On/Off	00-3F: OFF, 40h-7Fh: ON
00 09	PE4 On/Off	00-3F: OFF, 40h-7Fh: ON

1-2 SYSTEM REALTIME MESSAGES

Status[H]	Description
F8	Timing Clock *4
FE	Active Sensing (Everytime)

*4 : This message is transmitted when Arpeggio is "On" and the clock source is set "Internal".

1-3 UNIVERSAL SYSTEM EXCLUSIVE MESSAGES

DEVICE INQUIRY REPLY

Byte[H]	Description
F0	Exclusive Status
7E	Non Realtime Message
0g	MIDI GLOBAL CHANNEL (DEVICE ID)
06	INQUIRY MESSAGE
02	IDENTITY REPLY
42	KORG ID (MANUFACTURERS ID)
41	Prophecy Series ID (FAMILY CODE (LSB))
00	(" " (MSB))
01	(MEMBER CODE (LSB))
00	(" " (MSB))
xx	(Minor Ver. (LSB))
xx	(" " (MSB))
xx	(Major Ver. (LSB))
xx	(" " (MSB))
F7	END OF EXCLUSIVE

This message is transmitted whenever a INQUIRY MESSAGE REQUEST is received.

1-4 SYSTEM EXCLUSIVE MESSAGES

Function ID [Hex]	Description
40	CURRENT PROGRAM DATA DUMP *1
4C	PROGRAM DATA DUMP
69	ARPEGGIO PATTERN DATA DUMP
51	GLOBAL DATA DUMP
50	ALL DATA(GLOBAL, PROGRAM, PATTERN) DUMP
41	PARAMETER CHANGE *2
26	DATA FORMAT ERROR
23	DATA LOAD COMPLETED
24	DATA LOAD ERROR
21	WRITE COMPLETED
22	WRITE ERROR

*1 If "SysEx Transmit" parameter is set to "ON", the message is transmitted whenever a Program Change occurs.

*2 If "SysEx Transmit" parameter is set to "ON", the message is transmitted whenever a parameter is changed.

2. RECOGNIZED RECEIVE DATA

2-1 CHANNEL MESSAGES

Status [Hex]	Second [H] [D]	Third [H] [D]	Description
8n	kk (kk)	vv (vv)	Note Off
9n	kk (kk)	vv (vv)	Note On vv=0-127
Bn	00 (00)	mm (mm)	Program Bank Select(MSB)
Bn	01 (01)	vv (vv)	Pitch Modulation Depth
Bn	05 (05)	vv (vv)	Portamento Time
Bn	06 (06)	vv (vv)	Data Entry(MSB) *1
Bn	07 (07)	vv (vv)	Volume
Bn	0A (10)	vv (vv)	Panpot
Bn	0B (11)	vv (vv)	Expression
Bn	20 (32)	bb (bb)	Program Bank Select(LSB)
Bn	40 (64)	vv (vv)	Sustain Off/On
Bn	41 (65)	vv (vv)	Portamento Off/On
Bn	5B (91)	vv (vv)	Effect1 Depth (Distortion)
Bn	5C (92)	vv (vv)	Effect1 Depth (Wah)
Bn	5D (93)	vv (vv)	Effect1 Depth (Chorus/Flanger)
Bn	5E (94)	vv (vv)	Effect1 Depth (Delay)
Bn	5F (95)	vv (vv)	Effect1 Depth (Reverb)
Bn	60 (96)	xx (xx)	Data Increment *1
Bn	61 (97)	xx (xx)	Data Decrement *1
Bn	62 (98)	nl (nl)	NRPN LSB *1
Bn	63 (99)	nm (nm)	NRPN MSB *1
Bn	78(120)	00 (0)	All Sound Off
Bn	79(121)	00 (0)	Reset All Controller
Bn	7A(122)	00/7F (0/127)	Local Control Off/On
Bn	7B(123)	00 (0)	All Note Off
Bn	7C(124)	00 (0)	Omni Mode off
Bn	7D(125)	00 (0)	Omni Mode On
Bn	cc (cc)	vv (vv)	Control Data cc=00-101
Cn	pp (pp)	-- --	Program Change
Dn	vv (vv)	-- --	Channel Pressure (After Touch)
En	bb (bb)	bb (bb)	Pitch Bender Change

n : MIDI Channel No. (0-15)

vv: Value

*1 Non Registered Parameter Number

MSB LSB [H] [H]	Parameter	Data Entry(MSB) Value
00 01	Arpeggio Pattern Select	00-09: Int. Pat, 0Ah-13h: Card Pat
00 02	Arpeggio On/OFF	00-3F: OFF, 40h-7Fh: ON
00 03	Arpeggio Octaves	00-03: 1-4 Oct.
00 04	Arpeggiator Latch On/Off	00-3F: OFF, 40h-7Fh: ON
00 05	Arpeggiator Key Sync On/Off	00-3F: OFF, 40h-7Fh: ON
00 06	PE1 On/Off	00-3F: OFF, 40h-7Fh: ON

00 07	PE2 On/Off	00-3F: OFF, 40h-7Fh: ON
00 08	PE3 On/Off	00-3F: OFF, 40h-7Fh: ON
00 09	PE4 On/Off	00-3F: OFF, 40h-7Fh: ON

All these parameters can be changed by "Data Increment" and "Data Decrement".

2-2 SYSTEM REALTIME MESSAGES

Status[H]	Description
F8	Timing Clock
FE	Active Sensing

2-3 UNIVERSAL SYSTEM EXCLUSIVE MESSAGE (NON REALTIME)

DEVICE INQUIRY MESSAGE REQUEST

Byte[H]	Description
F0	Exclusive Status
7E	Non Realtime Message
0g	MIDI Channel
06	Inquiry Message
01	Inquiry Request
F7	END OF EXCLUSIVE

2-4 SYSTEM EXCLUSIVE MESSAGE

Function ID [Hex]	Function
10	CURRENT PROGRAM DATA DUMP REQUEST
1C	PROGRAM DATA DUMP REQUEST
34	ARPEGGIO PATTERN DATA DUMP REQUEST
0E	GLOBAL DATA DUMP REQUEST
0F	ALL DATA(GLOBAL, PROGRAM, PATTERN) DUMP REQUEST
11	PROGRAM WRITE REQUEST
40	CURRENT PROGRAM DATA DUMP
4C	PROGRAM DATA DUMP
69	ARPEGGIO PATTERN DATA DUMP
51	GLOBAL DATA DUMP
50	ALL DATA(GLOBAL, PROGRAM, PATTERN) DUMP
41	PARAMETER CHANGE

If "SysEx Receive" parameter is set to "ENABLE", these messages are recognized.

MIDI EXCLUSIVE FORMAT (R:Receive, T:Transmit)

(1) CURRENT PROGRAM DATA DUMP REQUEST

R

Byte	Description
F0,42,3g,41	EXCLUSIVE HEADER
0001 0000 (10)	CURRENT PROGRAM DATA DUMP REQUEST 10H
0000 0000 (00)	
1111 0111 (F7)	EOX

When this message id is received, the CURRENT PROGRAM DUMP(Function:40h) message will be transmitted.

(2) PROGRAM DATA DUMP REQUEST

R

Byte	Description
F0,42,3g,41	EXCLUSIVE HEADER
0001 1100 (1C)	PROGRAM DATA DUMP REQUEST 1CH
00uu 000b (kb)	Unit(00:Prog/01:Bank/10:All),Bank(0:A/1:B)
00pp dppp (pp)	Prog No. (Ignored when Bank or All dump.)
0000 0000 (00)	
1111 0111 (F7)	EOX

When this message id is received, the PROGRAM DUMP(Function:4Ch) message will be transmitted.

(3) ARPEGGIO PATTERN DATA DUMP REQUEST

R

Byte	Description
F0,42,3g,41	EXCLUSIVE HEADER
0011 0100 (34)	ARPEGGIO PATTERN DATA DUMP REQUEST 34H
000u ssss (ks)	Unit(0:Pattern/1:All), Patten No. (0-9)
0000 0000 (00)	
1111 0111 (F7)	EOX

When this message id is received, the ARPEGGIO PATTERN DUMP(Function:69h) message will be transmitted.

(4) GLOBAL DATA DUMP REQUEST

R

Byte	Description
F0,42,3g,41	EXCLUSIVE HEADER
0000 1110 (0E)	GLOBAL DATA DUMP REQUEST 0EH
0000 0000 (00)	
1111 0111 (F7)	EOX

When this message id is received, the GLOBALS DATA DUMP(Function:51h) message will be transmitted.

(5) ALL DATA(GLOBAL,PROGRAM,PATTERN) DUMP REQUEST

R

Byte	Description
F0,42,3g,41	EXCLUSIVE HEADER
0000 1111 (0F)	ALL DATA(GLOBAL,PROG,PAT) DUMP REQ 0FH
0000 0000 (00)	
1111 0111 (F7)	EOX

When this message id is received, the ALL DATA DUMP(Function:50h) message will be transmitted.

(6) PROGRAM WRITE REQUEST

R

Byte	Description
F0,42,3g,41	EXCLUSIVE HEADER
0001 0001 (11)	PROGRAM WRITE REQUEST 11H
0000 000b (0b)	Destination Program Bank(0:A/1:B)
00pp dppp (pp)	Destination Program No.(0-63)
1111 0111 (F7)	EOX

When this message id is received, a WRITE COMPLETED(Function:21h) message or a WRITE ERROR(Function:22h) message will be transmitted.

(7) CURRENT PROGRAM DATA DUMP

R/T

Byte	Description
F0,42,3g,41	EXCLUSIVE HEADER
0100 0000 (40)	CURRENT PROGRAM DATA DUMP 40H
0000 0001 (01)	Program Type
0ddd dddd (dd)	Data (NOTE 1)
:	:
1111 0111 (F7)	EOX

When this message id is received, a DATA LOAD COMPLETED(Function:23h) message or a DATA LOAD ERROR(Function:24h) message will be transmitted.

(8) PROGRAM DATA DUMP

R/T

Byte	Description
F0,42,3g,41	EXCLUSIVE HEADER
0100 1100 (4C)	PROGRAM DATA DUMP 4CH
00uu 000b (ub)	Unit(00:Prog/01:Bank/10:All),Bank(0:A/1:B)
00pp dppp (pp)	Program No. (Ignored when Bank or All dump.)
0000 0000 (00)	
0ddd dddd (dd)	Data (NOTE 1)
:	:
1111 0111 (F7)	EOX

When this message id is received, a DATA LOAD COMPLETED(Function:23h) message or a DATA LOAD ERROR(Function:24h) message will be transmitted.

(9) ARPEGGIO PATTERN DATA DUMP

R/T

Byte	Description
F0,42,3g,41	EXCLUSIVE HEADER
0110 1001 (69)	SEQUENCE DATA DUMP 69H
000u ssss (us)	Unit(0:Pattern/1:All), Patten No.(0-9)
0000 0000 (00)	
0ddd dddd (dd)	Data (NOTE 1)
:	:
1111 0111 (F7)	EOX

When this message id is received, a DATA LOAD COMPLETED(Function:23h) message or a DATA LOAD ERROR(Function:24h) message will be transmitted.

(10) GLOBAL DATA DUMP

R/T

Byte	Description
F0,42,3g,41	EXCLUSIVE HEADER
0101 0001 (51)	GLOBAL DATA DUMP 51H
0000 0000 (00)	
0ddd dddd (dd)	Data (NOTE 1)
:	:
1111 0111 (F7)	EOX

When this message id is received, a DATA LOAD COMPLETED(Function:23h) message or a DATA LOAD ERROR(Function:24h) message will be transmitted.

(11) ALL DATA(GLOBAL, PROGRAM, PATTERN) DUMP

R/T

Byte	Description
F0,42,3g,41	EXCLUSIVE HEADER
0101 0000 (50)	ALL DATA(GLOBAL, PROG, PAT) DUMP 50H
0000 0000 (00)	
0000 0000 (00)	
0ddd dddd (dd)	Data(Global->Program->Pattern) (NOTE 1)
:	:
1111 0111 (F7)	EOX

When this message id is received, a DATA LOAD COMPLETED(Function:23h) message or a DATA LOAD ERROR(Function:24h) message will be transmitted.

(12) PARAMETER CHANGE

R/T

Byte	Description
F0,42,3g,41	EXCLUSIVE HEADER
0100 0001 (41)	PARAMETER CHANGE 41H
0000 00mm (0m)	Group(00:Global/01:Program/10:Pattern)
0ppp pppp (pp)	Parameter ID (LSB)
0ppp pppp (pp)	Parameter ID (MSB)
0vvv vvvv (vv)	Value (LSB bit6-0)
0vvv vvvv (vv)	Value (MSB bit13-7) (NOTE 12)
1111 0111 (F7)	EOX

When this message id is received, a DATA LOAD COMPLETED(Function:23h) message or a DATA LOAD ERROR(Function:24h) message will be transmitted.

(13) DATA FORMAT ERROR

T

Byte	Description
F0,42,3g,41	EXCLUSIVE HEADER
0010 0110 (26)	DATA FORMAT ERROR 26H
1111 0111 (F7)	EOX

(14) DATA LOAD COMPLETED

T

Byte	Description
F0,42,3g,41	EXCLUSIVE HEADER
0010 0011 (23)	DATA LOAD COMPLETED 23H
1111 0111 (F7)	EOX

(15) DATA LOAD ERROR

T

Byte	Description
F0,42,3g,41	EXCLUSIVE HEADER
0010 0100 (24)	DATA LOAD ERROR 24H
0000 0ccc (0c)	Error Code (NOTE 2)
1111 0111 (F7)	EOX

(16) WRITE COMPLETED

T

Byte	Description
F0,42,3g,41	EXCLUSIVE HEADER
0010 0001 (21)	WRITE COMPLETED 21H
1111 0111 (F7)	EOX

(17) WRITE ERROR

T

Byte	Description
F0,42,3g,41	EXCLUSIVE HEADER
0010 0010 (22)	WRITE ERROR 22H
0000 0ccc (0c)	Error Code (NOTE 2)
1111 0111 (F7)	EOX

NOTE 1 : DUMP DATA CONVERSION

```

DATA ( 1set = 8bit x 7Byte )
b7  -  b0  b7  -  b0  b7  --  b0  b7  -  b0
+-----+ +-----+ +-----+ +-----+
| | | | | | | | | | | | | | | | | | | | | |
+-----+ +-----+ +-----+ +-----+
          7n+0          7n+1          7n+2 -- 7n+5          7n+6
    
```

```

MIDI DATA ( 1set = 7bit x 8Byte )
b7b7b7b7b7b7b7  b6  -  b0  b6  --  b0  b6  -  b0
+-----+ +-----+ +-----+ +-----+
|0| | | | | | | | | | | | | | | | | | | | | |
+-----+ +-----+ +-----+ +-----+
7n+6,5,4,3,2,1,0          7n+0          7n+1 -- 7n+5          7n+6
    
```

NOTE 2 : Error Code

ccc = 001:Program Memory Protected
ccc = 010:Pattern Memory Protected

Program Parameters

ParamID (12bits)	Parameter Name	Value	Size(byte)
* Program Common Parameter(138)			
1-16	Program Name		16
17	Program Category		1(Bit0-3)
18	User Category		^(Bit4-7)
19	Oscillator Mode	(SOLO)	1(Bit0-1)
20	reserved	(-)	^(Bit2)
21	Hold	(ON/OFF)	^(Bit3)
22	Key Priority	(LOW/HIGH/LAST)	^(Bit4-5)
23	Trigger Mode	(MULTI/SINGLE/VELOCITY)	^(Bit6-7)
	(Retrigger Velocity Control)		
24	Threshold Velocity	(1-127)	1(Bit0-6)
25	Above/Below	(ABOVE/BELOW)	^(Bit7)
26	Scale Key	(C-B)	1(Bit0-3)
27	Scale Type	(0-15)	^(Bit4-7)
28	Random Pitch Intensity	(0-99)	1
29	reserved	(-)	1
[EG1]			
30	Start Level	(-99-+99)	1
31	Attack Time	(0-99)	1
32	Attack Level	(-99-+99)	1
33	Decay Time	(0-99)	1
34	Break Point	(-99-+99)	1
35	Slope Time	(0-99)	1
36	Sustain Level	(-99-+99)	1
37	Release Time	(0-99)	1
38	Release Level	(-99-+99)	1
	(Time KBD TRK)		
39	Attack Time	(-99-+99)	1
40	Decay Time	(-99-+99)	1
41	Slope Time	(-99-+99)	1
42	Release Time	(-99-+99)	1
	(Velocity Control)		
43	Level	(-99-+99)	1
44	Attack Time	(-99-+99)	1
45	Decay Time	(-99-+99)	1
46	Slope Time	(-99-+99)	1
47	Release Time	(-99-+99)	1
48-	[EG2]		18
66-	[EG3]		18
84-	[EG4]		18
[LFO1]			
102 *4	Wave Form	(0-29)	1(Bit0-4)
103	Key Sync SW	(OFF/ON)	^(Bit7)
104	Mode	(ON/OFF/BOTH)	^(Bit5-6)
105	Frequency	(0-199)	1

ParamID (12bits)	Parameter Name	Value	Size(byte)
106	Frequency KBD TRK	(-99~+99)	1
107	Frequency CC#1 Control	(-99~+99)	1
108 *3	Frequency Mod.Source	(0-111)	1
109	Frequency Mod.Intensity	(-99~+99)	1
110	Offset	(-99~+99)	1
111 *3	Amplitude Mod.Source	(0-111)	1
112	Amplitude Mod.Intensity	(-99~+99)	1
113	Delay	(0-99)	1
114	Fade In	(-99~+99)	1
115-	[LFO2]		11
128-	[LFO3]		11
141-	[LFO4]		11
* Wave Form Generator(121)			
[OSC Common](20)			
154 *1	OSC Set	(Set1-Set12)	1
(Pitch EG)			
155	Start Level	(-99~+99)	1
156	Attack Time	(0-99)	1
157	Attack Level	(-99~+99)	1
158	Decay Time	(0-99)	1
159	Break Point	(-99~+99)	1
160	Slope Time	(0-99)	1
161	reserved	(-)	1
162	Release Time	(0-99)	1
163	Release Level	(-99~+99)	1
(Pitch EG KBD TRK)			
164	Level	(-99~+99)	1
165	Time	(-99~+99)	1
(Pitch EG Velocity Control)			
166	Level	(-99~+99)	1
167	Time	(-99~+99)	1
(Pitch Bender)			
168	Intensity(+X)	(-60~+12)	1
169	Intensity(-X)	(-60~+12)	1
170 *5	Step(+X)	(1-15)	1(Bit0-3)
171 *5	Step(-X)	(1-15)	^(Bit4-7)
172	After Touch Bending	(-12~+12)	1
(Portamento)			
173	Fingered Mode	(NORMAL/FINGERED)	1(Bit7)
174	Portamento Time	(0-99)	^(Bit0-6)
175	Portamento Time Velocity Control	(-99~99)	1
[OSC1](48)			
(Basic Pitch)			
176	Octave	(32"-4")	1
177	Semi Tone	(-12~+12)	1
178	Fine Tune	(-50~+50cent)	1
179	Frequency Offset	(-10.0~+10.0Hz)	1

ParamID (12bits)	Parameter Name	Value	Size(byte)
(Pitch Slope)			
180	Low Key	(C-1-G9)	1
181	High Key	(C-1-G9)	1
182 *8	Lower Slope	(-1.00~+2.00)	1
183 *8	Higher Slope	(-1.00~+2.00)	1
184 *3	Pitch Mod.LFO	(LFO1-LFO4)	1
185	Pitch Mod.LFO Intensity	(-99~+99)	1
186	Pitch Mod.LFO Int.AT Control	(-99~+99)	1
187	Pitch Mod.LFO Int.CC#1 Control	(-99~+99)	1
188 *3	Pitch Mod.Srouce	(0-111)	1
189	Pitch Mod.Intensity	(-99~+99)	1
*2 (OSC1 Setting)			34
[OSC2](48)			
(Basic Pitch)			
190	Octave	(32"-4")	1
191	Semi Tone	(-12~+12)	1
192	Fine Tune	(-50~+50cent)	1
193	Frequency Offset	(-10.0~+10.0Hz)	1
(Pitch Slope)			
194	Low Key	(C-1-G9)	1
195	High Key	(C-1-G9)	1
196 *8	Lower Slope	(-1.00~+2.00)	1
197 *8	Higher Slope	(-1.00~+2.00)	1
198 *3	Pitch Mod.LFO	(LFO1-LFO4)	1
199	Pitch Mod.LFO Intensity	(-99~+99)	1
200	Pitch Mod.LFO Int.AT Control	(-99~+99)	1
201	Pitch Mod.LFO Int.CC#1 Control	(-99~+99)	1
202 *3	Pitch Mod.Srouce	(0-111)	1
203	Pitch Mod.Intensity	(-99~+99)	1
*2 (OSC2 Setting)			34
[Sub OSC](3)			
204	Pitch Source	(OSC1/OSC2)	1(Bit7)
205	Relative Semi Tone	(-24~+24)	^(Bit0-6)
206	Relative Fine Tune	(-50~+50cent)	1
207	Wave Form	(SIN/SAW/SQU/TRI)	1
[Noise Generator](2)			
208	Noise LPF Frequency	(0-99)	1
209	Noise LPF Frequency KBD TRK	(-99~+99)	1

ParamID (12bits)	Parameter Name	Value	Size(byte)
• Wave Shape(26)			
(OSC1 Wave Shaping)			
210	Input Gain	(0-99)	1
211 *3	Input Gain Mod.Source	(0-111)	1
212	Input Gain Mod.Intensity	(-99~+99)	1
213	Input Offset	(-99~+99)	1
214	reserved	(-)	1
215	reserved	(-)	1
216	Feedback Level	(0-99)	1
217	Cross Loop Level	(0-99)	1
218	Shape Table Select	(CLIP/RESO)	1(Bit7)
219	Shape	(0-99)	^(Bit0-6)
220 *3	Shape Mod.Source	(0-111)	1
221	Shape Mod.Intensity	(-99~+99)	1
222	Output Gain	(0-99)	1
223	Thru Gain	(0-99)	1
224-	(OSC2 Wave Shape)		13

ParamID (12bits)	Parameter Name	Value	Size(byte)
• Mixer(30)			
(OSC1 Mixer Output1)			
238	Level	(0-99)	1
239 *3	Level Mod.Srource	(0-111)	1
240	Level Mod.Intensity	(-99~+99)	1
241-	(OSC1 Mixer Output2)		3
244-	(OSC2 Mixer Output1)		3
247-	(OSC2 Mixer Output2)		3
250-	(Sub OSC Mixer Output1)		3
253-	(Sub OSC Mixer Output2)		3
256-	(Noise Mixer Output1)		3
259-	(Noise Mixer Output2)		3
262-	(Feedback Mixer Output1)		3
265-	(Feedback Mixer Output2)		3

ParamID (12bits)	Parameter Name	Value	Size(byte)
• Filter(33)			
268	Filter Routing	(SERI1/SERI2/PARA)	1
[Filter 1](16)			
269	Filter Type	(THRU/LPF/HPF/BPF/BRF)	1
270	Input Trim	(0-99)	1
271	Cutoff Frequency	(0-99)	1
(Cutoff Frequency KBD TRK)			
272	Low Key	(C-1-G9)	1
273	High Key	(C-1-G9)	1
274	Lower Intensity	(-99~+99)	1
275	Higher Intensity	(-99~+99)	1

276 *3	Cutoff Frequency Mod.EG	(EG1-EG4/P.EG/A.EG)	1
277	Cutoff Frequency Mod.EG Int.	(-99~+99)	1
278 *3	Cutoff Frequency Mod.LFO	(LFO1-LFO4)	1

ParamID (12bits)	Parameter Name	Value	Size(byte)
279	Cutoff Frequency Mod.LFO Int.	(-99~+99)	1
280 *3	Cutoff Frequency Mod.Source	(0-111)	1
281	Cutoff Frequency Mod.Intensity	(-99~+99)	1
282	Resonance	(0-99)	1
283 *3	Resonance Mod.Source	(0-111)	1
284	Resonance Mod.Intensity	(-99~+99)	1
285-	[Filter 2](16)		16

ParamID (12bits)	Parameter Name	Value	Size(byte)
• Amplitude(36)			
[Amp 1](9)			
301	Amplitude	(0-99)	1
(Amplitude KBD TRK)			
302	Low Key	(C-1-G9)	1
303	High Key	(C-1-G9)	1
304	Lower Intensity	(-99~+99)	1
305	Higher Intensity	(-99~+99)	1
306 *3	Amplitude Mod.EG	(A.EG/P.EG/EG1-4)	1
307	Amplitude Mod.EG Intensity	(-99~+99)	1
308 *3	Amplitude Mod.Source	(0-111)	1
309	Amplitude Mod.Intensity	(-99~+99)	1
310-	[Amp 2](9)		
[Amp EG](18)			
319	Start Level	(0-99)	1
320	Attack Time	(0-99)	1
321	Attack Level	(0-99)	1
322	Decay Time	(0-99)	1
323	Break Point	(0-99)	1
324	Slope Time	(0-99)	1
325	Sustain Level	(0-99)	1
326	Release Time	(0-99)	1
327	reserved	(-)	1
(Amplitude EG KBD TRK)			
328	Attack Time	(-99~+99)	1
329	Decay Time	(-99~+99)	1
330	Slope Time	(-99~+99)	1
331	Release Time	(-99~+99)	1
(Amplitude EG Velocity Control)			
332	Level	(-99~+99)	1
333	Attack Time	(-99~+99)	1
334	Decay Time	(-99~+99)	1
335	Slope Time	(-99~+99)	1
336	Release Time	(-99~+99)	1

ParamID (12bits)	Parameter Name	Value	Size(byte)
• Distortion(8)			
337	Gain	(0-99)	1
338 *3	reserved	(-)	1
339	reserved	(-)	1
340	Tone	(0-99)	1
341	Level	(0-99)	1
342	Effect Balance	(0-100%)	1
343 *3	Effect Balance Mod.Source	(0-111)	1
344	Effect Balance Mod.Intensity	(-99-+99)	1
• Wah(9)			
345	Resonance	(0-99)	1
346	Low Frequency	(0-99)	1
347	High Frequency	(0-99)	1
348 *3	Sweep Source	(0-111)	1
349	Sweep Direction	(+/-)	1
350	Level	(0-99)	1
351	Effect Balance	(0-100%)	1
352 *3	Effect Balance Mod.Source	(0-111)	1
353	Effect Balance Mod.Intensity	(-99-+99)	1
• Delay/Reverb(22)			
354	Delay/Reverb Select	(CHORUS&DELAY/REVERB)	1
[Chorus/Flanger] (9)			
355	Delay Time	(0-99)	1
356	Feedback	(-99-+99)	1
357 *3	LFO Select	(LFO1-4)	1
358	Depth	(0-99)	1
359 *3	Depth Mod.Source	(0-111)	1
360	Depth Mod.Intensity	(0-99)	1
361	Effect Balance	(0-100%)	1
362 *3	Effect Balance Mod.Source	(0-111)	1
363	Effect Balance Mod.Intensity	(-99-+99)	1
[Delay] (6)			
364	Delay Time	(0-99)	1
365	Feedback	(0-99)	1
366	High Dump	(0-99)	1
367	Effect Balance	(0-100%)	1
368 *3	Effect Balance Mod.Source	(0-111)	1
369	Effect Balance Mod.Intensity	(-99-+99)	1
[Reverb] (6)			
370	Pre Delay	(0-99)	1
371	Reverb Time	(0-99)	1
372	High Dump	(0-99)	1
373	Effect Balance	(0-100%)	1
374 *3	Effect Balance Mod.Source	(0-111)	1
375	Effect Balance Mod.Intensity	(-99-+99)	1

ParamID (12bits)	Parameter Name	Value	Size(byte)
• 2 Band PEQ(6)			
376	High Freq	(0-49)	1
377	High Q	(0-29)	1
378	High Gain	(-18-+18dB)	1
379	Low Freq	(0-49)	1
380	Low Q	(0-29)	1
381	Low Gain	(-18-+18dB)	1
• Output(6)			
382	Panpot	(0-127)	1
383 *3	Panpot Mod.Source	(0-111)	1
384	Panpot Mod.Intensity	(-99-+99)	1
385	Output Level	(0-127)	1
386	reserved	(-)	1
387	reserved	(-)	1

ParamID (12bits)	Parameter Name	Value	Size(byte)
(Std.OSC) (9)			
388	Wave Select	(SAW/PULSE)	(1)
389	Wave Edge	(0-99)	(1)
390	Wave Level	(0-99)	(1)
391	Ramp Wave Level	(0-99)	(1)
392	Wave Form	(-99-+99)	(1)
393 *3	Wave Form Mod.LFO	(LFO1-LFO4)	(1)
394	Wave Form Mod.LFO Intensity	(-99-+99)	(1)
395 *3	Wave Form Mod.Source	(0-111)	(1)
396	Wave Form Mod.Intensity	(-99-+99)	(1)
(Comb Filter OSC) (10)			
397	Noise Level	(0-99)	(1)
398	Input Wave Form	(SAW/SQU/TRI)	(1)
399	Input Wave Level	(0-99)	(1)
400	Input Gain	(0-99)	(1)
401	Comb Filter Feedback	(0-99)	(1)
402 *3	Feedback Mod.EG	(EG1-EG4/P.EG/A.EG)	(1)
403	Feedback Mod.EG Intensity	(-99-+99)	(1)
404 *3	Feedback Mod.Source	(0-111)	(1)
405	Feedback Mod.Intensity	(-99-+99)	(1)
406	Loop LPF Frequency	(0-99)	(1)
(VPM OSC) (24)			
(Carrier)			
407	Carrier Wave	(SIN/SAW/TRI/SQU)	(1)
408	Carrier Level	(0-99)	(1)
409 *3	Carrier Level Mod.EG	(EG1-EG4/P.EG/A.EG)	(1)
410	Carrier Level Mod.EG Intensity	(-99-+99)	(1)
411 *3	Carrier Level Mod.Source	(0-111)	(1)

ParamID (12bits)	Parameter Name	Value	Size(byte)
412	Carrier Level Mod.Intensity	(-99~+99)	(1)
413	Table Shape	(0-99)	(1)
414 *3	Table Shape Mod.LFO	(LFO1-LFO4)	(1)
415	Table Shape Mod.LFO Intensity	(-99~+99)	(1)
416 *3	Table Shape Mod.Source	(0-111)	(1)
417	Table Shape Mod.Intensity	(-99~+99)	(1)
418	Feedback Gain	(0-99)	(1)
(Modulator)			
419	Frequency Semi Tone	(-12~+96)	(1)
420	Frequency Fine Tune	(-50-50)	(1)
421	Modulator Pitch Keyboard Track	(-99~+99)	(1)
422 *3	Modulator Pitch Mod.Source	(0-111)	(1)
423	Modulator Pitch Mod.Intensity	(-99~+99)	(1)
424	Modulator Wave	(SIN/SAW/TRI/SQU/OSC)	(1)
425	Modulator Level	(0-99)	(1)
426 *3	Modulator Level Mod.EG	(EG1-EG4/P.EG/A.EG)	(1)
427	Modulator Level Mod.EG Int.	(-99~+99)	(1)
428	Modulator Level Mod.EG Int.KTrk	(-99~+99)	(1)
429 *3	Modulator Level Mod.Source	(0-111)	(1)
430	Modulator Level Mod.Intensity	(-99~+99)	(1)
(Mod.OSC)(11)			
431	Modulation Type	(RING/CROSS/SYNC)	(1)
432	Input Select	(OSC1/F.B./Noise)	(1)
(Ring Modulation)			
433	Ring Carrier Select	(SIN/SAW/SQU)	(1)
(Cross Modulation)			
434	Cross Carrier Select	(SIN/SAW/SQU)	(1)
435	Cross Modulation Depth	(0-99)	(1)
436 *3	Cross Mod.Depth Mod.EG	(EG1-EG4/P.EG/A.EG)	(1)
437	Cross Mod.Depth Mod.EG Intensity	(-99~+99)	(1)
438 *3	Cross Mod.Depth Mod.Source	(0-111)	(1)
439	Cross Mod.Depth Mod.Intensity	(-99~+99)	(1)
(Sync Modulation)			
440	Sync Slave Wave Select	(SAW/TRI)	(1)
441	Sync Modulator Shape	(0-99)	(1)
(Brass OSC)(34)			
442 *6	Instrument Type	(0-3)	(1)
443 *3	Smooth Bending Controller	(0-111)	(1)
444	Smooth Bending Intensity	(0-12)	(1 Bit0-5)
445	Smooth Bending Direction	(UP/DOWN/BOTH)	(^ Bit6-7)
446 *3	Pressure EG	(EG1-EG4/P.EG/A.EG)	(1)
447	Pressure EG Intensity	(-99~+99)	(1)
448 *3	Pressure EG Int.Mod.Source	(0-111)	(1)
449	Pressure EG Int.Mod.Intensity	(-99~+99)	(1)

ParamID (12bits)	Parameter Name	Value	Size(byte)
450 *3	Pressure LFO	(LFO1-LFO4)	(1)
451	Pressure LFO Intensity	(-99~+99)	(1)
452 *3	Pressure Mod.Source	(0-111)	(1)
453	Pressure Mod.Intensity	(-99~+99)	(1)
454	reserved	(-)	(1)
455	reserved	(-)	(1)
456	Lip Charactor	(0-99)	(1)
457 *3	Lip Charactor Mod.Source	(0-111)	(1)
458	Lip Charactor Mod.Intensity	(-99~+99)	(1)
459	reserved	(-)	(1)
460	reserved	(-)	(1)
461	Bell Type	(OPEN/MUTE)	(1)
462	Bell Tone	(0-99)	(1)
463	Bell Resonance	(0-99)	(1)
464	Noise Level	(0-99)	(1)
465-476	reserved	(-)	(12)
(Reed OSC)(34)			
477 *7	Instrument Type	(0-12)	(1)
478 *3	Smooth Bending Controller	(0-111)	(1)
479	Smooth Bending Intensity	(0-12)	(1 Bit0-5)
480	Smooth Bending Direction	(UP/DOWN/BOTH)	(^ Bit6-7)
481 *3	Pressure EG	(EG1-EG4/P.EG/A.EG)	(1)
482	Pressure EG Intensity	(0-99)	(1)
483 *3	Pressure EG Int.Mod.Source	(0-111)	(1)
484	Pressure EG Int.Mod.Intensity	(-99~+99)	(1)
485 *3	Pressure LFO	(0-111)	(1)
486	Pressure LFO Intensity	(-99~+99)	(1)
487 *3	Pressure Mod.Source	(0-111)	(1)
488	Pressure Mod.Intensity	(-99~+99)	(1)
489	reserved	(-)	(1)
490	reserved	(-)	(1)
491 *3	Reed Mod.Source	(0-111)	(1)
492	Reed Mod.Intensity	(-99~+99)	(1)
493	reserved	(-)	(1)
494	reserved	(-)	(1)
495	reserved	(-)	(1)
496	reserved	(-)	(1)
497	reserved	(-)	(1)
498	Noise Level	(0-99)	(1)
499-511	reserved	(-)	(13)
(Pluck OSC)(30)			
512	Attack Level	(0-99)	(1)
513	Attack Level Velocity Control	(-99~+99)	(1)
514	Attack Noise Level	(0-99)	(1)
515	Attack Noise Level Vel.Control	(-99~+99)	(1)

ParamID (12bits)	Parameter Name	Value	Size(byte)
516	Attack Noise Filter Type	(LFF/HPF/BPF)	(1)
517	Attack Noise Filter Fc	(0-99)	(1)
518	Attack Noise Filter Fc Vel.Ctl.	(-99-+99)	(1)
519	Attack Noise Filter Resonance	(0-99)	(1)
520	Attack Curve Up	(0-99)	(1)
521	Attack Curve Up Velocity Ctl.	(-99-+99)	(1)
522	Attack Curve Down	(0-99)	(1)
523	Attack Curve Down Velocity Ctl.	(-99-+99)	(1)
524	Attack Edge	(0-99)	(1)
525	String Position	(0-99)	(1)
526	String Position Velocity Ctl.	(-99-+99)	(1)
527 *3	String Position Mod.Source	(0-111)	(1)
528	String Position Mod.Intensity	(-99-+99)	(1)
529	String Loss	(0-99)	(1)
530	String Loss Keyboard Track	(-99-+99)	(1)
531 *3	String Loss Mod.Source	(0-111)	(1)
532	String Loss Mod.Intensity	(-99-+99)	(1)
533	Inharmonicity Amount	(0-99)	(1)
534	Inharmonicity Keyboard Track	(-99-+99)	(1)
535	Decay	(0-99)	(1)
536	Decay Keyboard Track	(-99-+99)	(1)
537	Release	(0-99)	(1)
538	Release Keyboard Track	(-99-+99)	(1)
539	reserved	(-)	(1)
540	reserved	(-)	(1)
541	reserved	(-)	(1)

ParamID (12bits)	Parameter Name	Value	Size(byte)
* Controller Assignment(9)			
542 *9	Wheel1	(0-100)	1
543 *9	Wheel2	(0-100)	1
544 *9	Wheel3(+)	(0-100)	1
545 *9	Wheel3(-)	(0-100)	1
546 *9	Ribbon(X)	(0-100)	1
547 *9	Ribbon(Z)	(0-100)	1
548 *9	Foot Pedal	(0-100)	1
549 *10	Foot SW	(0-11)	1
550	Ribbon(X) Variable Center Point	(OFF/ON)	1

ParamID (12bits)	Parameter Name	Value	Size(byte)
* Performance Editor(91)			
[PE1] (20)			
(Knob1)			
551	Parameter	(0-255)	1
552	Left Value	(0-100%)	1
553	Right Value	(0-100%)	1
554	Curve	{LINER/EXP/LOG}	1
555-	(Knob2)		4
559-	(Knob3)		4
563-	(Knob4)		4
567-	(Knob5)		4
571-	[PE2]		20
591-	[PE3]		20
611-	[PE4]		20
631	PE1 SW	(OFF/ON)	1(Bit0)
632	PE2 SW	(OFF/ON)	^(Bit1)
633	PE3 SW	(OFF/ON)	^(Bit2)
634	PE4 SW	(OFF/ON)	^(Bit3)
635	PE Nob1 Value	(0-127)	1
636	PE Nob2 Value	(0-127)	1
637	PE Nob3 Value	(0-127)	1
638	PE Nob4 Value	(0-127)	1
639	PE Nob5 Value	(0-127)	1
640	Portamento SW	(OFF/ON)	1
641	reserved	(0)	1
642	reserved	(0)	1
643	reserved	(0)	1
644	reserved	(0)	1

• Format of Program Parameter ID for Parameter Change Message (Sys Ex).



ExID (4bits)	
0	(Identified by Parameter ID only.)
1	OSC 1
2	OSC 2

• Notes:

[*1] OSC Set

#set	OSC 1	OSC 2
Set 1	Std.OSC	Std.OSC
Set 2	Std.OSC	Comb Filter OSC
Set 3	Std.OSC	VPM OSC
Set 4	Std.OSC	Modulation OSC
Set 5	Comb Filter OSC	Comb Filter OSC
Set 6	Comb Filter OSC	VPM OSC
Set 7	Comb Filter OSC	Modulation OSC
Set 8	VPM OSC	VPM OSC
Set 9	VPM OSC	Modulation OSC
Set 10	Brass	no oscillator
Set 11	Reed	no oscillator
Set 12	Pluck	no oscillator

[*2] Determined by "OSC Set" parameter.

[*3] Modulation Source

ID	Modulation Source
0	Off
1	EG1
2	EG2
3	EG3
4	EG4
5	Pitch EG
6	Amp EG
7	LFO1
8	LFO2
9	LFO3
10	LFO4
11	Portamento
12	Note No.
13	Velocity
14	Pitch Bender

15	After Touch
16	Control Change #0
:	:
111	Control Change #95

[*4] LFO Wave Form

ID	Wave Form
0	SIN '0
1	SIN '180
2	COS '0
3	COS '180
4	TRI '0
5	TRI '90
6	TRI '180
7	TRI '270
8	SAW UP '0
9	SAW UP '180
10	SAW DOWN '0
11	SAW DOWN '180
12	SQR '0
13	SQR '180
14	RANDOM 1
15	RANDOM 2
16	RANDOM 3
17	RANDOM 4
18	RANDOM 5
19	RANDOM 6
20	Growl
21	Guitar Vibrato
22	Step TRI
23	Step SAW
24	Step TRI4
25	Step SAW6
26	Exp SAW UP
27	Exp SAW DOWN
28	Exp TRI
29	String Vibrato

[*5] Pitch Bender Step

- 0 :Continuous
- 1 :1/8[Semitone]
- 2 :1/4
- 3 :1/2
- 4 :1
- :
- 15:12

[*6] TRUMPET1/TRUMPET2/TRONBONE/HORN

[*7] SSAX/ASAX1/ASAX2/TSAX1/TSAX2/BSAX/FLUTE/SREED
/DREED/RECORDER/BOTTOL/GLASS BOTTLE/MONSTER

[*8] -1.00(-50)-0.00(0),+0.02(+1)-+1.00(+50)-+2.00(+100)

[*9]

ID	Controller
0	Off
1	Pitch Bend+/-
2	Pitch Bend+
3	Pitch Bend-
4	After Touch
5	Control Change #0
:	:
100	Control Change #95

[*10] Foot SW Function

ID	Modulation Source
0	Off
1	Sustain
2	Octave Up
3	Octave Down
4	Protamento SW
5	Distortion SW
6	Wah SW
7	Delay SW
8	Chorus SW
9	Reverb SW
10	Arpeggio OFF/ON
11	Wheel3 Hold

Global Parameters

ParamID (12bits)	Parameter Name	Value	Size(byte)
(System Setting)			(164)
1	Master Tune	(430.0Hz-450.0Hz)	1
2	Key Transpose	(-12~+12)	1
3	Velocity Curve	(CURVE1-8)	1
4	After Touch Curve	(CURVE1-8)	1
5	After Touch Sense	(0-99)	1
6	Ribbon 2 Sense	(0-99)	1
7	Foot Pedal Polarity	(+/-)	1(Bit0)
8	Foot SW Polarity	(+/-)	^(Bit1)
9	Transpose Position	(POST_KBD/PRE_TG)	^(Bit2)
10	Octave Switch Mode	{Latch/Unlatch}	^(Bit3)
11	Page Memory	(OFF/ON)	^(Bit4)
12	10's Hold	(OFF/ON)	^(Bit5)
13	DelayReverb	(ON/BYPASS)	^(Bit6)
14-25	User Scale1	(-100~+100cent)	12
26-153	User Scale2	(-100~+100cent)	128
154-169	System Name		16
170	Program Memory Protect	(OFF/ON)	1(Bit0)
171	Arpeggio Pattern Memory Protect	(OFF/ON)	^(Bit0)
(Knob Controller Assign)			(5)
172[*1]	Knob1 Controller	(0-100)	1
173[*1]	Knob2 Controller	(0-100)	1
174[*1]	Knob3 Controller	(0-100)	1
175[*1]	Knob4 Controller	(0-100)	1
176[*1]	Knob5 Controller	(0-100)	1
(Arpeggiator Controller Assign)			(2)
177[*2]	Velocity Controller	(0-98)	1
178[*2]	Gate Controller	(0-98)	1
(EC5 Setting)			(5)
179[*3]	EC5 Function	(0-13)	1
180[*3]	EC5 Function	(0-13)	1
181[*3]	EC5 Function	(0-13)	1
182[*3]	EC5 Function	(0-13)	1
183[*3]	EC5 Function	(0-13)	1
(MIDI Setting)			(3)
184	Global MIDI Channel	(0-15)	1
185	Local Control	(OFF/ON)	1(Bit0)
186	Omni Mode	(OFF/ON)	^(Bit1)
187	Clock Source	{INT/EXT}	^(Bit2)
188	System Exclusive Transmit	{ENABLE/DISABLE}	1(Bit0)
189	System Exclusive Receive	{ENABLE/DISABLE}	^(Bit1)
(Program Change Operation)			(199)
190	Program Change Transmit	(OFF/ON)	1(Bit0)
191	Program Change Receive	(OFF/ON)	^(Bit1)

ParamID (12bits)	Parameter Name	Value	Size(byte)
(Program Bank Select Map)			
192	Bank A MSB	(OFF/0-127)	1
193	Bank A LSB	(OFF/0-127)	1
194	Bank B MSB	(OFF/0-127)	1
195	Bank B LSB	(OFF/0-127)	1
196	Bank C MSB	(OFF/0-127)	1
197	Bank C LSB	(OFF/0-127)	1
(Program Select Map)			
198	A00	(0-127)	1
:	:		
261	A63	(0-127)	1
262	B00	(0-127)	1
:	:		
325	B63	(0-127)	1
326	C00	(0-127)	1
:	:		
389	C63	(0-127)	1
(Pitch Bend Operation)			(2)
390	Pitch Bend Transmit	(OFF/ON)	1(Bit0)
391	Pitch Bend Recieve	(DIS/ENA/INTP)	^(Bit1-2)
392	Pitch Bend Return	(OFF/ON)	^(Bit3)
393	Pitch Bend Translation	(PBEND/ATOUCH/CC#0-95)	1
(After Touch Operation)			(2)
394	After Touch Transmit	(OFF/ON)	1(Bit0)
395	After Touch Recieve	(DIS/ENA/INTP)	^(Bit1-2)
396	After Touch Return	(OFF/ON)	^(Bit3)
397	After Touch Translation	(PBEND/ATOUCH/CC#0-95)	1
(Control Change #0 Operation)			(192)
398	Control Change #0 Transmit	(OFF/ON)	1(Bit0)
399	Control Change #0 Recieve	(DIS/ENA/INTP)	^(Bit1-2)
400	Control Change #0 Return	(OFF/ON)	^(Bit3)
401	Control Change #0 Translation	(PBEND/ATOUCH/CC#0-95)	1
402-	(Control Change #1 Operation)		2
406-	(Control Change #2 Operation)		2
:			
778-781	(Control Change #95 Operation)		2

574

[*1] Knob Controller Assign

ID	Controller
0	Off
1	Pitch Bend+/-
2	Pitch Bend+
3	Pitch Bend-
4	After Touch
5	Control Change #0
:	:
100	Control Change #95

[*2] Arpeggiator Controller Assign

ID	Controller
0	Off
1	Pitch Bend
2	After Touch
3	Control Change #0
:	:
98	Control Change #95

[*3] EC5 Function

ID	Modulation Source
0	Off
1	Sustain
2	Program Up
3	Program Down
4	Octave Up
5	Octave Down
6	Protamento SW
7	Distortion SW
8	Wah SW
9	Delay SW
10	Chorus SW
11	Reverb SW
12	Arpeggio OFF/ON
13	Wheel3 Hold

Arpeggio Pattern Parameters

ParamID (12bits)	Parameter Name	Value	Size(byte)
(Base Parameter)			(32)
1-16	reserved		16
17	reserved		1
18	Step Base	(4, 4T, 8, 8T, 16, 16T)	1
19	Sort	(OFF/ON)	1
20	Keyboard Scan Zone Bottom	(C-1-G9)	1
21	Keyboard Scan Zone Top	(C-1-G9)	1
22	Velocity	(1-127, KEY, STEP)	1
23	reserved		1
24	Velocity Controller Intensity	(-99--+99)	1
25	Gate	(1%-100%, STEP)	1
26	reserved		1
27	Gate Controller Intensity	(-99--+99)	1
28 [*1]	Arpeggio Type	(0-3)	1
29	Octave Alternation	(UP/DOWN/UP&DOWN)	1
30-32	reserved		3
(Step1)			
33	Offset	(-49--+49%)	1
34	Tone	(1-12, LOOP)	1
35	Velocity	(1-127)	1
36	Gate	(OFF, 1%-100%)	1
37-	(Step2)		4
:	:		:
125-128	(Step24)		4

128

[*1] Arpeggio Type

0:As Played
 1:As Played(Fill)
 2:Running Up
 3:Up & Down

6.7 Troubleshooting

Problem	Action
Nothing appears in the LCD when the POWER switch is pressed.	<ul style="list-style-type: none"> • Is the power cable connected to an AC outlet? →P/B G, P.4 • Is the amp turned on and connected correctly?
No sound!	<ul style="list-style-type: none"> • Are the amp, and/or headphones connected correctly? →P/B G, P.4 • Is the Master Volume of the Prophecy raised? →P/B G, P.6 • Is the Global section Local setting turned ON? →P/B G, P.5 • Are the level-related parameters in each section set to 0?
Sound does not stop!	<ul style="list-style-type: none"> • Is the Hold setting turned OFF? →P G, P.127 • Is the Damper Polarity setting correct? →P G, P.136
Sound is different than the settings!	<ul style="list-style-type: none"> • Have you executed the Write operation after editing? →P/B G, P.31
Cannot save data to card!	<ul style="list-style-type: none"> • Is the Protect switch of the card turned ON? →P G, P.152 • Are you using a ROM card? →P G, P.152 • Is the card inserted correctly? →P G, P.152 • Is the Global section Memory Protect setting OFF? →P G, P.148
Cannot load data from card!	<ul style="list-style-type: none"> • Does the card contain data? →P G, P.152 • Is the card inserted correctly? →P G, P.152
Delay or reverb settings do not work!	<ul style="list-style-type: none"> • Is the Global section Delay/Reverb setting ON? →P G, P.135
Cannot write programs!	<ul style="list-style-type: none"> • Is the Global section Memory Protect setting OFF? →P G, P.148
Transpose or Velocity Curve is not transmitted/received correctly!	<ul style="list-style-type: none"> • Are the Global section Transposition settings correct? →P G, P.133
Arpeggio does not start!	<ul style="list-style-type: none"> • Is the Global section Clock Source setting correct? →P G, P.139 • Is the Keyboard scan setting of Pattern Define correct? →P G, P.7
Cannot control through MIDI!	<ul style="list-style-type: none"> • Is the MIDI cable connected correctly? →P/B G, P.5 • Does the MIDI channel on which the external device is transmitting match the Global Channel of the Prophecy? →P G, P.139

6.8 Error messages

Error message	Action
Program write error	
WRITE ERROR <Program Memory is protected>	Turn off Program Memory Protect.
WRITE ERROR <Please insert CARD?>	Insert a card.
WRITE ERROR <Card is write protected>	Turn off the card's Write Protect switch.
Program Change error	
PROGRAM READ ERROR <Please insert CARD>	Insert a card.
Pattern Bank/Pattern Change error	
PATTERN READ ERROR <Please insert CARD>	Insert a card.
ACCESS ERROR <CARD is wrong format>	Insert the correct card.
Program Bank Select error	
ACCESS ERROR <Please insert CARD>	Insert a card.
ACCESS ERROR <CARD is wrong format>	Insert the correct card.
Battery Check error	
INTERNAL BATTERY IS LOW <Press any key>	The internal backup battery has run down. Contact your nearby dealer or a Korg service station.
CARD BATTERY IS LOW <Press any key>	The backup battery of the card has run down. Replace the battery.

6.9 Other messages

• Pattern define messages

* WARNING <PatternMemory is protected>	The ARPEGGIO PATTERN DEFINE key was pressed when Pattern Memory Protect is ON. If you wish to change the parameter values, turn Pattern Memory Protect OFF (GLB-20,4).
* CARD PAT CAN'T BE CHANGED <Copy to Int>	The ARPEGGIO PATTERN DEFINE key was pressed when a CARD PAT is selected. CARD PAT pattern parameters cannot be changed directly. Copy them to an INT PAT and modify them there.

MIDI receive messages

MIDI WRITE REQUEST RECEIVED <Completed>
EDIT PROGRAM DUMP RECEIVED <Completed>
PROGRAM DATA DUMP RECEIVED <Completed>
PATTERN DATA DUMP RECEIVED <Completed>
GLOBAL DATA DUMP RECEIVED <Completed>
ALL DATA DUMP RECEIVED <Completed>

Message	Situation and result
<Press ENTER>	A setting needs to be finalized. Waiting for the ENTER key.
<Are you sure?>	Waiting for confirmation by the ENTER key.
<Completed>	Processing of a Utility function etc. has been completed.
<Ignore>	In most cases, a copy or swap operation that changes nothing. Operation is abandoned.
<OSC Type Error>	In Oscillator Copy, the oscillator types are different. Operation is abandoned.
<Fx Type Error>	In Effect Copy, the effect types are different. Operation is abandoned.
<Center OK?>	When calibrating wheel 1 or 3, waiting for center settings.
<Value Mismatch>	When calibrating a controller, the setting is inappropriate. Operation is cancelled.
<Mem Protected>	During Factory Data Load or Arpeggio Pattern Copy etc., protect is on for Program or Pattern memory. Operation is cancelled.
<No Card>	In most cases, when card access is attempted when no card is inserted. Operation is cancelled.
<Illegal Format>	In most cases, when there is a problem with the card format during card access. Operation is cancelled.
<Format&Write?>	When writing or saving to a card, the card format is not correct. If the ENTER key is pressed, the card will be formatted and the Write or Save operation will be executed.
<Write Protect>	When saving is attempted for a card whose Protect switch is ON. Operation is cancelled.
<Card Trouble>	When a problem has occurred during card access. Operation is cancelled.
<Now Playing>	The demo songs are playing.

NOTICE

KORG products are manufactured under strict specifications and voltages required by each country. These products are warranted by the KORG distributor only in each country. Any KORG product not sold with a warranty card or carrying a serial number disqualifies the product sold from the manufacturer's/distributor's warranty and liability. This requirement is for your own protection and safety.

KORG KORG INC.

15 - 12, Shimotakaido 1 - chome, Suginami-ku, Tokyo, Japan.