

microSTATION

MUSIC WORKSTATION



Parameter guide

EDS-i Enhanced Definition
Synthesis - integrated

REMS

GENERAL
MI

KORG

About the Parameter Guide

The microSTATION Parameter Guide is divided into two sections: Quick Parameters and Full Parameters.

Quick Parameter section

The parameters that can be edited from the microSTATION itself are called "quick parameters." These are the microSTATION's most important parameters.

The Quick Parameter section explains these parameters.

Full Parameter section

"Full parameters" are the parameters that can be edited from microSTATION Editor installed on a computer connected to the microSTATION.

These include the detailed sound parameters, effect parameters, drum kits, and user arpeggio patterns.

The Full Parameter section explains these parameters.

Conventions in the operation manuals

Abbreviations for the manuals: OG, PG

In the documentation, references to the manuals are abbreviated as follows.

OG: Operation Guide

PG: Parameter Guide

Procedure steps 1. 2. 3. ...

These indicate the steps of a procedure.

Symbols, , , Note, Tips

These symbols respectively indicate a caution, a MIDI-related explanation, a supplementary note, or a tip.

Example screen displays

The parameter values shown in the example screens of this manual are only for explanatory purposes, and may not necessarily match the values that appear in the Display of your instrument.

MIDI-related explanations

CC# is an abbreviation for Control Change Number.

In explanations of MIDI messages, numbers in square brackets [] always indicate hexadecimal numbers.

- * Apple, Mac are trademarks of Apple Inc., registered in the U.S. and other countries.
- * Windows XP, Windows Vista, and Windows 7 are a registered trademark of Microsoft Corporation in the U.S. and other countries.
- * Intel, Intel Core, and Pentium are trademarks of Intel Corporation in the U.S. and other countries.
- * All product names and company names are the trademarks or registered trademarks of their respective owners.

Table of contents

About the Parameter Guide	ii	Combination mode	17
Conventions in the operation manuals	ii	COMBI PLAY	17
microSTATION Quick parameters	1	COMBI EDIT	17
Program mode	3	Timbd \forall (Timbre Parameters)	17
PROG PLAY	3	Timbre 01	17
PROG EDIT	3	Timbre 02....16	23
OSC Common	3	Knob Assign	23
Filter/Amp	5	Tempo	23
Filter/Amp EG	6	ARP (Arpeggiator)	23
Filter EG	6	IFX1, IFX2, IFX3, IFX4, IFX5	25
Amp EG	6	MFX1, MFX2	26
Pitch EG/LFO	6	TFX (Total Effect)	26
LFO	6	Master Vol	26
OSC1	7	Command	27
OSC2	8	Write Combi	28
Audition Riff	8	External Setup	28
Knob Assign (Realtime Control Knob B Assign) .	9	Sequencer mode	29
Tempo	9	An overview of Sequencer mode	29
ARP Setup	9	SEQ	31
FX Routing	11	PLAY	31
IFX1, IFX2, IFX3, IFX4, IFX5	11	REC	34
MFX1, MFX2	13	EDIT	36
TFX	13	Tracks	36
Master Vol	13	Track Edit	42
Command	14	Knob Assign	45
Write Program	14	Tempo	45
External Setup	15	ARP (Arpeggiator)	45
		IFX1, IFX2, IFX3, IFX4, IFX5	46
		MFX1, MFX2	47
		TFX (Total Effect)	47
		Master Vol	47
		Command	48
		Song Command	48
		External Setup	51
		Grid Seq (Grid Sequence)	51
		Grid Sequence Parameters	52
		System Exclusive events supported in Sequencer mode	55

Global/Media mode 57**Basic 57**

Effect SW	59
ARP (Arpeggiator)	59
Bank Map	59
Initial Song	60
Scroll Text	60
M.Protect (Memory Protect)	60

MIDI 60

MIDI Clock	62
SEQ MIDI Out	62
ARP RTC MIDI	63
MIDI Filter	63
External Setup	64

Controllers 65

PEDAL/SW	65
----------------	----

Command 66**Write Global 66****Media 67**

Load	68
Save All	69
Save PCG	69
Save SEQ	69
Save To SMF (Save Song as Standard MIDI File)	69
Rename	69
Delete	70
Format	70

**microSTATION Full parameters
..... 71****Program mode 73****Panel 74**

Mode Select, BROWSER, UTILITY	74
Display	74
Realtime Controls	74
Arpeggiator	74

Quick 75

Overview	75
OSC Common	76
OSC EG/LFO	77
OSC1	78
OSC2	79
About Relative (Rel) and Absolute parameters ..	79
ARP/Controllers	80

Basic 82

OSC Mode	82
Scale	82
Half-Damper Control	83
Key Zone	83
Program Basic	84
Controllers	86
ARP	87

OSC/Pitch 88

OSC1	88
OSC2	89
PITCH EG	89
OSC1 Multisample	89
OSC1 Pitch	91
OSC2 Multisample	93
OSC2 Pitch	93
OSC Common	94
Pitch EG	96

Filter 99

Filter1	99
Filter2	101
Filter1 Modulation 102	
Filter1 LFO Mod.	105
Filter1 EG	107

Filter2 109

Filter2	109
Filter2 Modulation	109
Filter2 LFO Mod.	109
Filter2 EG	109

Amp	110
Amp1	110
Amp2	111
Amp1 Modulation	111
Amp1 EG	113
Amp2 Modulation	115
Amp2 EG	115
LFO	116
OSC 1	116
OSC 2	117
Common	117
OSC1 LFO1	118
OSC1 LFO2	119
OSC2 LFO1	119
OSC2 LFO2	119
Common LFO	120
AMS Mix/C.KeyTrk (AMS Mixer/ Common Keyboard Track)	121
OSC1	121
OSC 2	122
OSC1 AMS Mix	122
OSC 2 AMS Mix	126
Common KeyTrack (Common Keyboard Track)	127
IFX (Insert Effect)	129
IFX Routing	129
OSC MFX Send	129
Routing	130
IFX Setup	131
IFX1	133
IFX2, IFX3, IFX4, IFX5	133
MFX/TFX (Master/Total Effect)	134
MFX&TFX Routing	134
Routing	135
MFX1	136
MFX2	136
TFX	136
UTILITY Command	137

Combination mode	139
Panel	140
Mode Select, BROWSER, UTILITY	140
Display	140
Realtime Controls	140
Arpeggiator	140
Play	141
Program Select	141
Timbre Mixer	142
Common	143
Arpeggiator Assign	143
Arpeggiator-A(B)	143
Realtime Control Knob Assign	144
Timbre Param (Timbre Parameters)	145
Scale	145
MIDI/OSC	145
Pitch/Other	147
Tone	149
MIDI Filter1	150
MIDI Filter2	151
Key/Vel Zone (Keyboard/Velocity Zone)	152
Keyboard Zones	152
Velocity Zone	152
IFX (Insert Effect)	153
IFX Routing	153
Routing	153
IFX Setup	155
IFX1	156
IFX2, IFX3, IFX4, IFX5	156
MFX/TFX (Master/Total Effect)	157
MFX&TFX Routing	157
Routing	157
MFX1	158
MFX2	158
TFX	158
UTILITY Command	159

Sequencer mode	161	Drum Kit	188
Panel	162	Drum Kit	188
Mode Select, BROWSER, UTILITY	162	Sample Param	189
Display	162	Voice/Mixer	191
Realtime Controls	162	Creating a drum kit	192
Arpeggiator	162	Arpeggio Pattern	195
Play	163	Common	195
Track Select, Program Select, Pan, Volume ...	163	Setup	196
Track Mixer	163	Fixed Note	196
Common	164	Edit	196
Track Param (Track Parameters)	166	Creating a user arpeggio pattern	197
Scale	166	UTILITY Command	202
MIDI/OSC	166	Effect Guide	205
Pitch/Other	167	Overview	205
Tone	168	Effects in each mode	205
MIDI Filter 1	169	Editing effect parameters	
MIDI Filter 2	170	on the microSTATION itself	205
Key/Vel Zone (Keyboard/Velocity Zone)	171	Dynamic modulation (Dmod)	
IFX (Insert Effect)	172	and Tempo Synchronization	206
IFX Routing	172	FX Control Bus	207
Routing	172	Effect I/O	207
IFX Setup	173	Insert Effects (IFX1–IFX5)	208
IFX1	174	In/Out	208
IFX2, IFX3, IFX4, IFX5	174	Routing	208
MFX/TFX (Master/Total Effect)	175	Mixer	210
MFX&TFX Routing	175	Controlling the Insert Effects via MIDI	211
Routing	175	Master Effects (MFX1, 2)	211
MFX1	176	In/Out	211
MFX2	176	Routing	212
TFX	176	Mixer	213
UTILITY Command	177	Controlling the Master Effects via MIDI	213
Global mode	179	Total Effect (TFX)	214
Panel	180	In/Out	214
Mode Select, UTILITY	180	Routing	214
Display	180	Mixer	214
Realtime Controls	180	Using MIDI to control the Total Effect	214
Arpeggiator	180	Main Outputs	214
Software Setup	181	Effect/Mixer Block Diagram	215
Basic/Controllers	182	Single size effects	217
MIDI	184	000: No Effect	217
External	185	001: St.Comp (Stereo Compressor)	217
User Scale	186	002: Red Comp	217
Category	187	003:St. Limitr (Stereo Limiter).....	218
		004: MulLimir (Multiband Limiter)	219
		005: St.MstLmt (Stereo Mastering Limiter) ...	219
		006: St.Gate (Stereo Gate)	219
		007: St.P4EQ (Stereo Parametric 4-Band EQ) ..	220
		008: St.G7EQ (Stereo Graphic 7-Band EQ)	221

009: St.Excitr (Stereo Exciter)	221	052: Limtr - Phsr	244
010: St.Isolat (Stereo Isolator)	222	053: Xctr - Comp (Exciter - Compressor)	245
011: St. Wah (Stereo Wah/Auto Wah)	222	054: Xctr- Lmtr	245
012: St.VtgWah (Stereo Vintage/Custom Wah)	223	055: Xctr- Phsr	246
013: VOX Wah	224	056: OD - Amp (Overdrive/Hi.Gain - Amp Simulation) ..	246
014: St.RndFlt (Stereo Random Filter)	224	057: OD - Phsr (Overdrive/Hi.Gain - Phaser).....	247
015: St.MMFltr (Multi Mode Filter).....	225	058: Wah - Amp (Wah - Amp Simulation)	247
016: St.SubOsc (Stereo Sub Oscillator)	226	059: Deci - Amp (Decimator - Amp Simulation)	248
017: Talk Mod (Talking Modulator)	226	060: Deci - Comp (Decimator - Compressor) ..	248
018: St.Decimt (Stereo Decimator)	227	061: Amp - Trml (Amp Simulation- Tremolo) ..	248
019: St. Record (Stereo Analog Record)	228	062: Organ Vib/Chorus (Organ Vibrato/Chorus)	249
020: OD Wah (Overdrive/Hi.Gain Wah)	228	063: Rotary SP (Rotary Speaker)	249
021: St.Gt Cab (Stereo Guitar Cabinet)	229	064: St.Chorus (Stereo Chorus)	250
022: St.Bs Cab (Stereo Bass Cabinet)	230	065: VtgChorus (Vintage Chorus)	251
023: Bass Amp.....	230	066: BlkChorus (Black Chorus)	251
024: B.Amp Cab (Bass Amp Model+Cabinet) ...	231	067: St.HrmCho (Stereo Harmonic Chorus) ...	252
025: TrebleBST (Treble Booster)	231	068: St.Bi Mod (Stereo Biphase Modulation)	252
026: Tube Pre (Tube PreAmp Modeling)	232	069: Mtap Cho (Multitap Chorus/Delay)	253
027: St.TubPre (Stereo Tube PreAmp Modeling)	232	070: Ensemble	253
028: Mic Model (Mic Modeling + PreAmp) ...	232	071: Poly6 Ens (Polysix Ensemble).....	254
029: Stereo Phaser	233	072: St Flange (Stereo Flanger)	254
030: Small Phs (Small Phaser)	233	073: VtgFlange (Vintage Flanger)	254
031: OrangePhs (Orange Phaser)	234	074: St.RndFlg (Stereo Random Flanger)	255
032: BlackPhsr (Black Phaser)	234	075: St.EnvFlg (Stereo Envelope Flanger)	255
033: U-VIBE	234	076: St.Vibrat (Stereo Vibrato)	256
034: St.RndPhs (Stereo Random Phaser)	234	077: St.AF Mod (Stereo Auto Fade Modulation)	257
035: St.EnvPhs (Stereo Envelope Phaser)	235	078: Doppler	257
036: 2Vo.Reso (2Voice Resonator)	235	079: Detune	258
037: St.Tremlo (Stereo Tremolo)	236	080: PitchSftr (Pitch Shifter)	258
038: TEX Treml (TEX Tremolo)	237	081: P.Sft Mod (Pitch Shift Modulation)	259
039: St. Env.Trm (Stereo Envelope Tremolo)	237	082: P4EQ - Flng (Parametric 4-Band EQ - Chorus/Flanger)	260
040: St.AutPan (Stereo Auto Pan)	237	083: Comp - Flng (Compressor - Chorus/Flanger)	260
041: St.PhsTrm (Stereo Phaser + Tremolo) ...	238	084: Lmtr - Flng (Limiter - Chorus/Flanger) ...	261
042: St.Ring M (Stereo Ring Modulator)	239	085: Xctr - Flng (Exciter - Chorus/Flanger).....	261
043: P4EQ - Xctr (Parametric 4-Band EQ - Exciter)	240	086: OD - Flng (Overdrive/Hi.Gain - Chorus/Flanger)....	262
044: P4EQ - Wah (Parametric 4-Band EQ - Wah/Auto Wah).....	240	087: Phsr - Flng (Phaser - Chorus/Flanger) ...	262
045: P4EQ - Phaser (Parametric 4-Band EQ - Phaser)	241	088: GrainSftr (Grain Shifter)	263
046: Comp - Wah (Compressor - Wah/Auto Wah)	241	089: LCR Delay	263
047: Comp - Amp (Compressor - Amp Simulation)	242	090: St.Delay (Stereo/CrossDelay)	264
048: Comp - OD (Compressor - Overdrive/Hi.Gain)	242	091: St.MtpDly (Stereo Multitap Delay)	264
049: Comp - P4EQ (Compressor - Parametric 4-Band EQ) .	243	092: St.ModDly (Stereo Modulation Delay) ...	265
050: Comp - Phsr (Compressor - Phaser).....	243	093: St.DynDly (Stereo Dynamic Delay).....	266
051: Lmtr - P4EQ (Limiter - Parametric 4-Band EQ).....	244	094: St.PanDly (Stereo Auto Panning Delay) ..	266
		095: Tape Echo	267
		096: Echo Plus	268

097: Auto Reverse	268
098: SeqDlyBPM (Sequence BPM Delay)	269
099: LCR BPM (L/C/R BPM Delay)	269
100: St.DlyBPM (Stereo BPM Delay)	270
101: St.MtdBPM (Stereo BPM Multitap Delay)	270
102: St.ModBPM (Stereo BPM Modulation Delay)	271
103: St.ApdBPM (Stereo BPM Auto Panning Delay)	272
104: TapeE BPM (Tape Echo BPM)	273
105: Rev.Hall (Reverb Hall)	274
106: Rev.Plate (Reverb Plate)	274
107: Rev.Room1 (Reverb Room)	274
108: Rev.Room2 (Reverb Room)	274
109: R2.Spring (Reverb2 Spring)	275
110: R2.Hall (Reverb2 Hall)	275
111: R2.Plate (Reverb2 Plate)	275
112: R2.Room (Reverb2 Room)	275
113: Early Reflections	275
114: P4EQ - MDly (Parametric 4-Band EQ - Multitap Delay)	276
115: Comp - MDly (Compressor - Multitap Delay)	276
116: Lmtr - MDly (Limiter - Multitap Delay)	277
117: Xctr - MDly (Exciter - Multitap Delay)	277
118: OD - MDly (Overdrive/Hi.Gain - Multitap Delay)	278
119: Flng - Dly (Chorus/Flanger - Multitap Delay)	278
120: Rev - Gate (Reverb - Gate)	279
Double Size effects	280
D00: St.MltLmt (Stereo Multiband Limiter)	280
D01: OD/HG Wah (Overdrive/Hyper Gain Wah)	280
D02: GAmp + P4EQ (Guitar Amp Model + Parametric 4-Band EQ)	281
D03: GAmpCLEAN (Guitar Amp Model CLEAN)	282
D04: GAmpSUPER (Guitar Amp Model SUPER)	282
D05: GAmpTWEED (Guitar Amp Model TWEED)	282
D06: GAmpUS-HG (Guitar Amp Model US-HG)	282
D07: B.TubeAmp (Bass Tube Amp Model + Cabinet)	282
D08: St. Mic (Stereo Mic Modeling + PreAmp)	283
D09: Vocoder	283
D10: Rotary OD (Rotary Speaker Overdrive)	284
D11: Mtap Cho (Multitap Chorus/Delay)	285
D12: St.P.Sftr (Stereo Pitch Shifter)	286
D13: Early Ref (Early Reflections)	286

Appendices287

Alternate Modulation Source (AMS) 287

Alternate Modulation Overview	287
AMS (Alternate Modulation Source) List	287
Alternate Modulation settings	289

Dynamic Modulation Source (Dmod) 292

Realtime Control Knob 1–4 Assign 294

Foot Switch Assign 295

Foot Pedal Assign 296

MIDI transmission when the microSTATION's controllers are used 297

microSTATION and MIDI CCs 299

Responses to standard MIDI controllers	299
Parameters controlled by MIDI CCs #70-79	301

MIDI applications 302

About MIDI	302
Settings when connected to a MIDI device or computer	302
Messages transmitted and received by the microSTATION	302

Shortcuts 312

MIDI Implementation 313

microSTATION Quick parameters



Program mode

To play programs you'll use Program mode, which lets you do the following things.

- Select and play programs.
- Use the Realtime Control knobs to control a program's sound or arpeggiator.
- Edit the most important program parameters.

Page structure in Program mode

The microSTATION's Program mode is organized as a tree structure containing the following pages. (☞ p.3)
For details on how to move between pages, and how to select parameters and edit their values, please refer to the "microSTATION Operation Guide."

PROG PLAY

In PROG PLAY you can select and play programs. You can also use the Realtime Control knobs to control the program's sounds and the arpeggiator while you perform.

MIDI All MIDI data in PROG PLAY is transmitted and received on the global MIDI channel. (☞ "Channel (Global MIDI Channel)" on page 60)

Tips: Auto Song Setup

By pressing the REC button in Program or Combination mode, you can use the Auto Song Setup function which automatically copies the current settings to a song and puts the microSTATION in the record-ready condition. When you've thought of a phrase or an idea for a song, this lets you instantly turn your inspiration into a song. (☞ "Tips: Auto Song Setup" on page 30)

Program No.&Name [001...: program name]

This indicates the program.

The microSTATION's preload programs are organized into the following seven categories. The category of the selected program is shown by the CATEGORY indicator located at the left of the front panel display.

Category	Explanation
ALL	No category. All programs 001...512: Programs of banks A, B, C, D 513...640: GM2 capital programs 641...768: GM2 variation programs 769...777: GM2 drum programs
KEYBOARD	A.Piano, Synth E.P, Real E.P, Clav/Harpsi, E.Organ, Pipe.Organ
STRINGS/BRASS/ WOODWIND	Strings, Vocal, Airy, Brass, Woodwind, Reed
GUITAR	A.Guitar, E.Guitar, Plucked
BASS&BASS SPLIT	E.Bass, A.Bass, Synth Bass
SYNTH	Fast, Slow, Motion, Short decay
LEAD&SOLO SPLIT	Syn Lead
DRUM/MALLET/ HITS	Natural, Dance, Perc, Bell, Mallet, SFX, Hits
USER	Sounds saved as a user category (not included in factory settings)

The preload programs include rewritable programs (a total of 512 programs), and the non-rewritable GM banks containing GM2 capital programs (128), variation programs (129), and bank 'g' drums (9).

Note: If you want to view the numbers within each bank rather than the numbers shown when ALL is selected, turn NUMLOCK on (LED lit) and press the 14 (ENTER) button.

EXTERNAL control

In PROG PLAY, if you press the EXTERNAL button to turn External Control on, and then operate knobs 1-4, the display will briefly show the MIDI channel, MIDI CC number and value that are assigned by the selected external setup. External setups can be selected in PROG EDIT: External Setup. (☞ "External Setup" on page 15)

 If the MIDI CC number for a knob is turned Off in the selected external setup, then the value will not appear when you operate the knob.

PROG EDIT

Here you can edit the microSTATION's program quick parameters. The quick parameters are major parameters that can be edited from the microSTATION itself. If you want to edit all parameters of the program, you'll need to use microSTATION Editor on a connected computer.

OSC Common

Here you can specify how oscillators 1 and 2 will produce sound.

Voice Mode (Voice Assign Mode) [Poly, Mono]

Select the basic voice allocation mode. Depending on which one you select, various other options will appear, such as "Mono Legato" and "Unison" (Mono mode only).

Poly: The program will play polyphonically, allowing you play chords.

Mono: The program will play monophonically, producing only one note at a time.

MonoLegato [Off, On]

This is available when the "Voice Mode" is set to **Mono**.

Legato refer to notes that are played in a way that they sound smooth and connected; the next note is played before the last note is released. This is the opposite of playing detached.

On: When you play with legato phrasing, the notes within a legato phrase will sound smoother.

When "Mono Legato" is **On**, the first note in a legato phrase will sound normally, and then subsequent notes will have a smoother sound, for more gentle transitions between the notes.

Off: Legato phrasing will produce the same sound as detached playing.

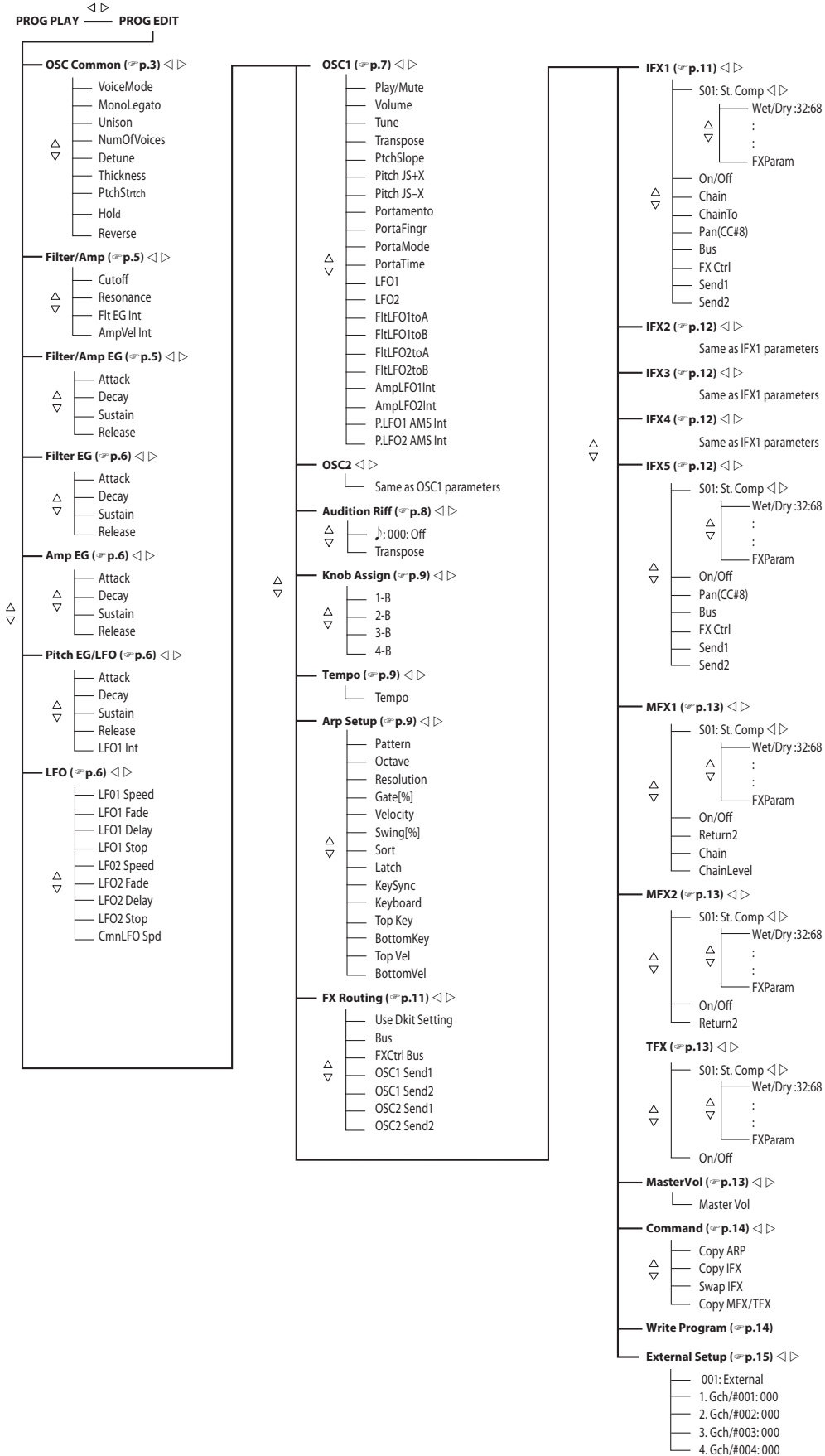

Unison**[On, Off]**

Unison can be used in **Mono** mode.

On: When Unison is on, the Program uses two or more stacked, detuned voices to create a thick sound. Use the “NumOfVoices” and “Detune” parameters to set the number of voices and amount of detuning, and the “Thickness” parameter to control the character of the detuning.

Off: The Program plays normally.

NumOfVoices (Number of Voices)**[2...6]**

This controls the number of detuned voices that will be played for each note when using “Unison.” It applies only when “Unison” is **On**.

Detune**[00...99 cents]**

Detune is available when “Unison” is **On**.

This parameter sets the tuning spread for the Unison voices, in cents (1/100 of a semitone). The “Thickness” parameter, below, controls how the voices are distributed across the detune amount. When “Thickness” is **Off**, the voices are distributed evenly, centered around the basic pitch.

☞ “Detune [cents]” on page 85

Thickness**[Off, 1...9]**

Thickness is available when “Unison” is **On**.

This parameter controls the character of the detuning function for the unison voices.

Off: Unison voices will be evenly distributed across the Detune range, as shown above.

1-9: Unison voices will be detune in an asymmetrical way, increasing the complexity of the detune function, and changing the way that the different pitches beat against one another. This creates an effect similar to vintage analog synthesizers, where oscillators would frequently drift slightly out of tune. Higher numbers increase the effect.

PtchStrtch**[-12...0...+12 (Rel)]**

This special control increases the Oscillator “Tune” parameter while lowering the “Transpose” parameter. The result is that the pitch stays the same, but the mapping of the samples to the keys changes. You can use this to create interesting shifts in timbre.

Hold**[Off, On]**

Hold is like permanently pressing down on the sustain pedal. In other words, notes continue to sound as if you were holding down the key - even after you lift your fingers from the keyboard.

Be aware that unless you set “Sustain” to 0 for Amp EG1 (and also Amp EG2 if the program uses two oscillators), the sound will continue indefinitely.

On: The Hold function is enabled.

 Even if the Hold function is enabled, it might be disabled for a specific range of keys (☞ “Hold Bottom Key” on page 83).

Off: Notes will play normally. This is the default setting.

Reverse**[PROG, Off, On (Rel)]**

This switches “Reverse” on/off for all multisamples used by both oscillators. If this is on, the waveform will play backward. By setting this to **PROG**, you can return the setting to the program’s original setting.

Tone parameters

Parameters from Filter/Amp to the LFO group allow you to make overall modifications to the program’s sound. (the microSTATION Editor allows full parameter editing.) With the exception of “LFO1Stop” and “LFO2Stop,” these parameters are relative parameters. They adjust the value relative to the setting specified by full parameter editing.

 Some parameters in this group are interrelated with control of certain MIDI CC messages. For these, an indication such as “CC#74” appears following the parameter value.

Filter/Amp

Here you can adjust filter and amp settings for oscillators 1 and 2.

Filter settings let you boost or attenuate specific frequency regions of the sound.

Amp settings control the volume.

Note: Relative parameters are indicated by “Rel” following the parameter value. Absolute parameters are indicated by “Abs” following the parameter value. For more about these parameters, please refer to “Relative (Rel) and Absolute parameters” (p.66).

Cutoff (Filter Cutoff)**[-99...+99 (Rel, CC#74)]**

This scales the cutoff frequency of all of the filters at once. It affects both Filters A and B.

Resonance (Filter Resonance)**[-99...+99 (Rel, CC#71)]**

This scales the resonance of all of the filters at once. It affects both Filters A and B.

Flt EG Int (Filter EG Intensity)**[-99...+99 (Rel, CC#79)]**

This scales the effect of the Filter EG on the cutoff frequency. It affects Filters A and B simultaneously.

-99 means no modulation. +99 means maximum. Modulation is in the same direction, positive or negative, as the original Program. For instance, if the original Program’s “EG Intensity” was set to -25, then setting this parameter to +99 moves the “EG Intensity” to -99.

AmpVel Int (Amp Velocity Intensity) [-99...+99 (Rel)]

This scales the effect of velocity on the Amp level.

-99 removes the velocity modulation entirely. +99 means maximum modulation in the same direction, positive or negative, as the original Program.

Filter/Amp EG

Here you can adjust the settings for the filter EG and amp EG of oscillators 1 and 2.

In the Filter/Amp EG group, all filter EGs and amp EGs are adjusted simultaneously. In contrast, each parameter is adjusted independently in the Filter EG and Amp EG groups.

A program contains three EGs: pitch, filter, and amp. These respectively produce time-varying change in the pitch, tone, and volume.

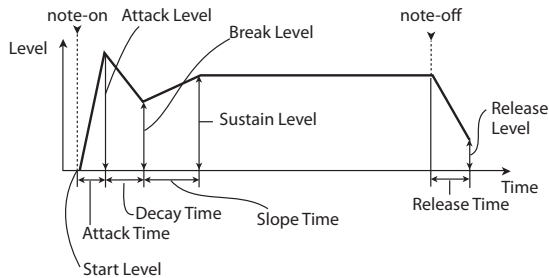

Attack (Filter/Amp EG Attack Time) [-99...+99 (Rel, CC#73)]

This scales the attack times of the Filter and Amp EGs, along with other related parameters.

When the value is +1 or more, this also affects the Amp EG's Start and Attack Levels, Start Level AMS, and Attack Time AMS.

Between values of +1 and +25, the Start Level, Start Level AMS, and Attack Time AMS will change from their programmed values to 0. Over the same range, the Attack Level will change from its programmed value to 99. (☞ "Alternate Modulation" on page 91)

Decay (Filter/Amp EG Decay Time) [-99...+99 (Rel, CC#75)]

This scales the decay and slope times of the Filter and Amp EGs.

Sustain (Filter/Amp EG Sustain Level) [-99...+99 (Rel, CC#70)]

This scales the sustain levels of the Filter and Amp EGs.

Release (Filter/Amp EG Release Time) [-99...+99 (Rel, CC#72)]

This scales the release times of the Filter and Amp EGs.

Filter EG

Here you can edit the filter EG envelope for oscillators 1 and 2.

Attack (Filter EG Attack Time) [-99...+99 (Rel)]

This scales the attack times of the Filter EGs.

Decay (Filter EG Decay Time) [-99...+99 (Rel)]

This scales the decay and slope times of the Filter EGs.

Sustain (Filter EG Sustain Level) [-99...+99 (Rel)]

This scales the sustain levels of the Filter EGs.

Release (Filter EG Release Time) [-99...+99 (Rel)]

This scales the release times of the Filter EGs.

Amp EG

Here you can edit the amp EG envelope for oscillators 1 and 2.

Attack (Amp EG Attack Time) [-99...+99 (Rel)]

This scales the attack times of the Amp EGs.

Decay (Amp EG Decay Time) [-99...+99 (Rel)]

This scales the decay and slope times of the Amp EGs.

Sustain (Amp EG Sustain Level) [-99...+99 (Rel)]

This scales the sustain levels of the Amp EGs.

Release (Amp EG Release Time) [-99...+99 (Rel)]

This scales the release times of the Amp EGs.

Pitch EG/LFO

Here you can edit the pitch EG envelope for oscillators 1 and 2, and specify the depth of the effect that LFO1 will have on the pitch.

Attack (Pitch EG Attack Time) [-99...+99 (Rel)]

This scales the attack time of the Pitch EG.

Decay (Pitch EG Decay Time) [-99...+99 (Rel)]

This scales the decay and slope times of the Pitch EG.

Release (Pitch EG Release Time) [-99...+99 (Rel)]

This scales the decay and slope times of the Pitch EG.

LFO1 Int (Pitch LFO1 Intensity) [-99...+99 (Rel, CC#77)]

This scales the effect of LFO1 on the Pitch.

-99 removes the LFO modulation entirely. +99 means maximum modulation in the same direction, positive or negative, as the original Program.

LFO

Here is where you can adjust LFO settings for oscillators 1 and 2.

Each oscillator has two LFOs (LFO1 and LFO2). There's also a common LFO that can be shared by the two oscillators. LFO1 and LFO2 are independent for each voice, but the common LFO is shared by all voices of the program. It's useful when you want to produce a uniform LFO effect that is the same for all voices.

LFO1 Speed [-99...+99 (Rel, CC#76)]

This scales LFO1's frequency.

(☞ "Frequency" on page 117)

LFO1 Fade [-99...+99 (Rel)]

This scales LFO1's fade-in time.

(☞ "Fade" on page 118)

LFO1 Delay [-99...+99 (Rel, CC#78)]

This scales LFO1's delay time - the time between note-on and the onset of the LFO.

(☞ "Delay" on page 118)

LFO1 Stop [PROG, Off, On (Abs)]

This Absolute parameter controls whether LFO1 is stopped or running.

(☞ "Stop" on page 118)

The PROG setting restores the Program's original values. For example, if you set this to PROG when the oscillator 1

LFO is stopped and oscillator 2 is playing, the original setting of the parameter will be used.

LFO2 Speed [-99...+99 (Rel)]

This scales LFO2's frequency.
(☞ "Frequency" on page 117)

LFO2 Fade [-99...+99 (Rel)]

This scales LFO2's fade-in time.
(☞ "Fade" on page 118)

LFO2 Delay [-99...+99 (Rel)]

This scales LFO2's delay time - the time between note-on and the onset of the LFO.
(☞ "Delay" on page 118)

LFO2 Stop [PROG, Off, On (Abs)]

This Absolute parameter controls whether LFO2 is stopped or running.
(☞ "Stop" on page 118)

CmnLFO Spd (Common LFO Speed) [-99...+99 (Rel)]

This scales the Common LFO's frequency.

OSC1

Here you can adjust settings for oscillator 1.

Play/Mute [Play, Mute]

Sets the Play/Mute of oscillators 1.

Play: Oscillator 1 will sound.

Mute: Oscillator 1 will be muted (silent).

To switch an oscillator's play/mute status, press the front panel PLAY/MUTE button to turn it on (the LED at the left of the button will light-up), and then use the function 01 button to control the play/mute status.

Volume [000...127]

Adjusts the volume of Oscillator 1.

Tune [-1200...+1200]

This Relative parameter adds to or subtracts from the Oscillator's Tune setting. (☞ "Tune" on page 94)

Transpose [-60...+60]

This Relative parameter adds to or subtracts from the Oscillator's Transpose setting. (☞ "Transpose" on page 94)

PtchSlope (Pitch Slope) [-1.0...+2.0]

Normally, this should be set to the default of +1.0.

Pitch Slope, pitch, and note

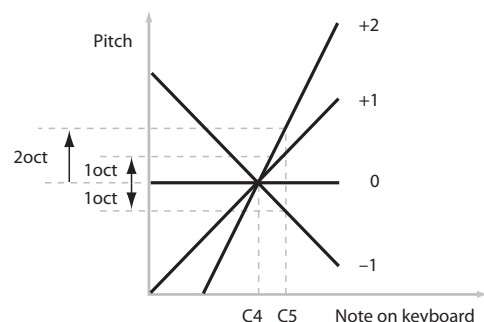

Positive (+) values cause the pitch to rise as you play higher on the keyboard, and negative (-) values cause the pitch to fall as you play higher on the keyboard.

When this is set to 0, playing different notes on the keyboard won't change the pitch at all; it will be as if you're

always playing C4. This can be useful for special effects sounds, for instance.

Pitch JS+X [-60...+12]

This specifies in semitones how much the pitch will change when the joystick is moved to the right (or when a pitch bend message is received). For normal pitch bend, set this to a positive value.

For example, if you set this to +12 and move the joystick all the way to the right, the pitch will rise one octave above the original pitch.

Pitch JS-X [-60...+12]

This specifies in semitones how the pitch will change when the joystick is moved to the left (or when a pitch bend message is received). For normal pitch bend, set this to a negative value.

For example, if you set this to -60 and move the joystick all the way to the left, the pitch will fall five octaves below the original pitch. You can use this to create guitar-style downward swoops.

Portamento (Portamento Enable) [Off, On]

Portamento lets the pitch glide smoothly between notes, instead of changing abruptly.

On: Turns on Portamento, so that pitch glides smoothly between notes.

Off: Turns off Portamento. This is the default state.

PortaFinger (Portamento Fingered) [Off, On]

This parameter allows you to control Portamento through your playing style. When it's enabled, playing legato will turn on Portamento, and playing detached will turn it off again.

This option is only available when "Portamento Enable" is turned on.

On: Turns on Fingered Portamento.

Off: Turns off Fingered Portamento.

PortaMode (Portamento Mode) [Rate, Time]

Rate means that Portamento will always take the same amount of time to glide a given distance in pitch - for instance, one second per octave. Put another way, gliding several octaves will take much longer than gliding a half-step.

Time means that Portamento will always take the same amount of time to glide from one note to another, regardless of the difference in pitch. This is especially useful when playing chords, since it ensures that each note in the chord will end its glide at the same time.

PortaTime (Portamento Time) [000...127]

This controls the portamento time. Higher values mean longer times, for slower changes in pitch.

This option is only available when "Portamento Enable" is turned on.

Assigning portamento on/off to an assignable pedal switch

Here's how to assign the portamento on/off function to a pedal switch connected to the microSTATION's Assignable PEDAL/SW jack. (☞ "Sw (Foot Switch function)" on page 65)

Adjust the settings as follows.

1. Access the GLOBAL/MEDIA: Controllers - PEDAL/SW page.
2. Set "Type" to Switch," and "SW" to Porta.SW.

Now you can use the pedal switch to turn portamento on/off. When you do so, MIDI control change (CC) #65 will be transmitted.

MIDI CC#65 can be received to turn portamento on/off.

LFO1 [Triangle...Rnd6(Cnt)]

This selects the basic LFO1 waveform. See "LFO waveform" on page 8.

Most of the waveforms should be self-explanatory, but a few will benefit from more details:

Guitar is intended for guitar vibrato, and its shape is specifically tuned for this purpose. The waveform is positive-only, so that when used for pitch, it will only bend up, and not down.

Random1 (S/H) generates traditional sample and hold waveforms, in which the level changes randomly at fixed intervals of time.

Random2 (S/H) randomizes both the levels and the timing.

Random3 (S/H) generates a pulse wave with random timing. It's the opposite of traditional sample and hold; the timing varies, but the levels don't.

Random4-6 (Continuous) are smoothed versions of Random 1-3, with ramps instead of steps. You can use them to create more gentle random variations.

LFO2 [Triangle...Rnd6(Cnt)]

This selects the basic LFO2 waveform, as shown in the graphic below "LFO waveform" below

FtLFO1toA (Filter LFO1 Intensity to A) [-99...+99]

This controls the depth and direction of Filter A cutoff modulation from LFO1.

LFO modulation of Filter Cutoff

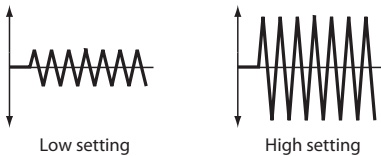

FtLFO1toB (Filter LFO1 Intensity to B) [-99...+99]

This controls the depth and direction of Filter B cutoff modulation from LFO1.

FtLFO2toA (Filter LFO 2 Intensity to A) [-99...+99]

This controls the depth and direction of Filter A cutoff modulation from LFO2.

☞ "FtLFO1toA (Filter LFO1 Intensity to A)" on page 8

FtLFO2toB (Filter LFO2 Intensity to B) [-99...+99]

This controls the depth and direction of Filter B cutoff modulation from LFO2.

LFO waveform

Triangle		Guitar		Step Tri4 (Step Triangle4)		Rnd1(S/H) (Random1 -S/H)		Rnd4(Cnt) (Random4 -Continuous)	
Saw		ExpTri (Exponential Triangle)		Step Tri6 (Step Triangle6)		Rnd2(S/H) (Random2 -S/H)		Rnd5(Cnt) (Random5 -Continuous)	
Square		ExpSawDwn (Exponential Saw Down)		Step Saw4		Rnd3(S/H) (Random3 -S/H)		Rnd6(Cnt) (Random6 -Continuous)	
Sine		ExpSawUp (Exponential Saw Up)		Step Saw6					

AmpLFO1Int (Amp LFO1 Intensity) [-99...+99]

This controls the depth and direction of Amp modulation from LFO1. Negative (-) settings will invert the phase of the LFO.

AmpLFO2Int (Amp LFO2 Intensity) [-99...+99]

This controls the depth and direction of Amp modulation from LFO2. Negative (-) settings will invert the phase of the LFO.

P.LFO1 AMS Int (Pitch LFO1 AMS Intensity) [-12.00...+12.00]

This specifies the depth and direction of the pitch modulation produced by AMS (LFO1).

With a setting of 0, modulation will not be applied. With a setting of 12.00, the AMS (LFO1) will apply a maximum of +/-1 octave of pitch modulation.

P.LFO2 AMS Int (Pitch LFO2 AMS Intensity) [-12.00...+12.00]

This is similar to Pitch LFO 1 AMS Intensity, above.

OSC2

Here you can adjust the settings for oscillator 2. These settings are available only for a program that uses two oscillators; they cannot be edited otherwise.

The parameters are the same as for oscillator 1.

☞ "OSC1" on page 7

Audition Riff

When you select a preload program, a previously specified audition riff (phrase) appropriate for that sound can play. This is called the Audition function.

If you press the AUDITION button to turn it on (the LED at the left of the button will light-up), the audition riff will play repeatedly.

Here's how to select the audition riff and transpose it.

Audition Riff [000: Off...383: name]

This selects the audition riff. The microSTATION contains 383 audition riffs that are suitable for a wide range of instrumental sounds and musical styles.

If you choose 000: Off, no riff will play.

Transpose [-24...+24]

This transposes the pitch of the audition riff in semitone steps.

🔺 You can't change the playback tempo of the audition riff. Nor can you set the arpeggiator tempo while the audition riff is playing.

🔺 The arpeggiator will be off while the audition riff is playing.

Knob Assign (Realtime Control Knob B Assign)

Here you can select the functions that are assigned to knobs 1–4 when Realtime Control B mode is selected.

- Knob1B** [Off...MIDI CC#95, CC#102...119]
- Knob2B** [Off...MIDI CC#95, CC#102...119]
- Knob3B** [Off...MIDI CC#95, CC#102...119]
- Knob4B** [Off...MIDI CC#95, CC#102...119]

Here you can select the functions (mainly types of control change) that are assigned to knobs 1–4 when Realtime Control B mode is selected.

When the RealTime Control is set to B mode, the four knobs on the right function as Realtime knobs 1–4.

These can perform a number of different functions, such as modulating sounds or effects, adjusting effects send levels, and so on.

The default assignments for knobs 1–4 are Knob Mod.1 (CC#17), Knob Mod.2 (CC#19), Knob Mod.3 (CC#20), and Knob Mod.4 (CC#21), respectively.

See “Realtime Control Knob 1–4 Assign” on page 294.)

Tempo

This is the tempo for the current Program, which applies to the arpeggiator, tempo-synced LFOs, and tempo-synced effects.

J (Tempo) [040.00...300.00, EXT]

Specify the tempo.

If Realtime Control C mode is selected, you can use knob 4 to adjust the tempo.

EXT is displayed if the Global/Media mode “Clock” is set to Ext.MIDI or Ext.USB. This is also shown if the “Clock” setting is Auto and MIDI clock data is being received from an external device. If the tempo source is EXT, the arpeggiator, LFO, and effects will synchronize to MIDI clock data from an external MIDI device.

ARP Setup

Here you can specify the arpeggiator settings used by the program.

When switching programs, you have the option of having these arpeggio settings automatically switch to the settings stored in that program. (☞ “Load ARP:” on page 59)

Use the ARP ON/OFF button to switch the arpeggio on/off. When on, the LED to left of the button will light-up.

The states of the ARP ON/OFF button, ARP LATCH button, and the Realtime Control C mode ARP GATE knob, ARP VELOCITY knob, ARP SWING knob, and TEMPO knob can be saved in each program.

MIDI You can control the arpeggiator from an external sequencer, or record note data generated by the arpeggiator onto an external sequencer. (☞ p.201)

Pattern [P0: UP...P4: RANDOM, 000...639: name]

Selects the arpeggio pattern.

Preset/User No	Contents
P0: UP...P4: RANDOM	Preset arpeggio patterns
000...511	Preloaded arpeggio patterns
512...639	User arpeggio patterns

Note: 000...639 are rewritable.

Note: You can select arpeggio patterns 000–511 by turning on the NUM LOCK key and using the 01 (1)–10 (0) buttons and 14 (ENTER) button to select the desired pattern.

Example: Preset pattern

The way in which the pattern is played will depend on settings such as “Octave” and “Sort.” P0...P4 in the following diagrams show how the arpeggio will be played when “Octave” is set to 1, and “Sort” is checked. P4: RANDOM is only one possibility. P0: UP



P1: DOWN



P2: ALT1



P3: ALT2



P4: RANDOM



Octave

[1, 2, 3, 4]

Specifies the number of octaves in which the arpeggio will be played.

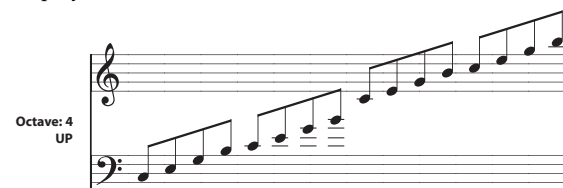

Resolution [♩, ♪, ♫, ♮, ♯, ♭, ♮]

Specifies the timing resolution of the arpeggio. The notes of the arpeggio will be played at the interval you specify: ♩, ♪, ♫, ♮, ♯, ♭, ♮, or ♩. The speed of the arpeggio pattern is determined by

Gate[%] [000...100, Step]

Specifies the length (gate time) of each note in the arpeggio.

000...100(%): Each note will be played with the specified gate time.

Step: This is available when a user arpeggio pattern 000...639 is selected for "Pattern." When this is selected, the gate time specified for each step will be used.

In Realtime Control C mode, you can also use the knob 1 (ARP GATE) to control this. Turning the knob toward the left shortens the gate time, and turning it toward the right lengthens the gate time. When the knob is in the 12 o'clock position, the gate time will be as specified here.

Velocity [001...127, Key, Step]

Specifies the velocity of the notes in the arpeggio.

001...127: Each note will sound with the specified velocity value.

Key: Each note will sound with the velocity value at which it was actually played.

Step: This is available when an user arpeggio pattern 000...639 is selected for "Pattern." When this is selected, the velocity specified for each step will be used.

In Realtime Control C mode, you can also use the knob 2 (ARP VELOCITY) to control this. Turning the knob toward the left will decrease the velocity, and rotating it toward the right will increase the velocity. When the knob is at the 12 o'clock position, the velocity will be as specified here.

When a preload user arpeggio pattern is selected, setting the "Gate[%]" or "Velocity" to Step will add a sense of groove to the arpeggio pattern.

Swing[%] [-100...+100]

This parameter shifts the timing of the odd-numbered notes of the arpeggio.

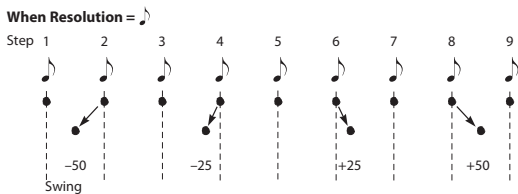

In Realtime Control C mode, you can also use knob 3 (ARP SWING) to control this.

Sort [Off, On]

This specifies the order in which the notes you press will be arpeggiated.

On: Notes will be arpeggiated in the order of their pitch, regardless of the order in which you pressed them.

Off: Notes will be arpeggiated in the order in which you pressed them.



Latch [Off, On]

Specifies whether or not the arpeggio will continue playing after you take your hand off of the keyboard.

On: The arpeggio will continue playing after you remove your hand from the keyboard.

Off: The arpeggio will stop when you remove your hand from the keyboard.

You can also use the front panel ARP LATCH button to control this parameter.

KeySync [Off, On]

Specifies whether the arpeggio pattern will begin when you press a key, or whether it will always follow the "♪ (Tempo)."

On: The arpeggio pattern will start playing from the beginning when a note-on occurs from a condition where no keys are pressed. This setting is suitable when you are playing in realtime and want the arpeggio to play from the beginning of the measure.

Off: The arpeggio pattern will always play according to the "♪ (Tempo)."

Keyboard [Off, On]

This specifies whether the notes you play on the keyboard will be sounded as usual in addition to being sounded as part of the arpeggio.

On: The notes you play will be sounded on their own, in addition to being sounded as part of the arpeggio. For example if you simultaneously press two or more notes, they will be sounded as usual in addition to being played as arpeggiated notes.

Off: Only the arpeggiated notes will be heard.

Note: You can use the command Copy Arpeggiator to copy arpeggiator settings from another program or combination. (☞ "Copy Arpeggio" on page 14)

Top Key [C-1...G9]

BottomKey [C-1...G9]

These parameters specify the range of notes (keys) for which the arpeggiator will function. "Top Key" is the upper limit, and "BottomKey" is the lower limit.

The arpeggiator will operate when you play keys within the specified range. Keys outside of this range can be played in the normal manner, and will not be affected by the arpeggiator on/off.

For example if you set Pattern to P0: UP, Latch on, set "Top Key" to B3, and "BottomKey" to C-1, playing a note B3 or lower will trigger the arpeggiator. Since "Latch" is on, the arpeggio will continue even after you release the keys. You can use the C4 and higher keys to play conventionally along with the arpeggio sounded by the B3 and lower keys. To change the arpeggio, play keys in the range of B3 and below.



Playing B3 and lower keys will trigger arpeggio pattern P0: UP

You can use C4 and higher keys to perform along with the arpeggio pattern.P

Top Vel [001...127]

Bottom Vel [001...127]

Specifies the range of velocities for which the arpeggiator will function. "Top Vel" is the upper limit, and "Bottom Vel" is the lower limit.

The arpeggiator will operate when you play notes with a velocity (playing strength) that is within the specified range. Notes played with a velocity outside this range will be sounded normally, without regard to the arpeggiator on/off. Note: Note number and velocity can also be entered by holding down the KEY button and playing a note on the keyboard.

FX Routing

Here you can specify how the effects will be routed. This consists mainly of the following settings.

- Input an oscillator's output to an insert effect.
- Input an oscillator's output to the FX control bus.
- Input an oscillator's output to the master effect.

Use Dkit Set [Off, On]

This setting is shown if the program's oscillator uses a drum kit. If the oscillator uses a multisample, this setting is ignored.

On: The FX routing settings for each key will be as specified by the drum kit used by the program's oscillator. Choose the On setting if you want to apply an insert effect to individual drum instruments.

Tip: In most preloaded drumkits, the drum instruments have the same "Bus" settings according to their type, as follows.

Snares → IFX1

Kicks → IFX2

Other → IFX3

Off: The "Bus," "FXCtrl Bus," "OSC1 Send," "OSC1 Send 2" settings will be used. All drum instruments will be sent to the specified bus.

Bus (Bus Select) [L/R, IFX1...IFX5, Off]

This specifies the output bus for oscillators 1 and 2.

L/R: The oscillators will be output to the L/R bus. Normally you will choose L/R.

IFX1...IFX5: Output to the IFX1–5 busses.

Off: The oscillator will not be output from the L/R bus, or IFX1–5 busses. Choose the Off setting if you want the program oscillator output to be connected in series to a master effect. Use "OSC1 Send1" and "OSC1 Send2" to specify the send levels.

FXCtrl Bus (FX Control Bus) [Off, 1, 2]

Sends the output of the oscillator 1, 2 to an FX Control bus (two-channel mono FX Ctrl 1 or 2).

Use the FX Control busses when you want a separate sound to control the audio input of an effect. You can use two FX Control busses (each is a two-channel mono bus) to control effects in various ways.

For more information, please see "FX Control Bus" on page 207.

OSC1 Send1 [000...127]

Sets the volume (send level) at which the output of oscillator 1 will be sent to master effect 1. This applies only when "Bus" is set to L/R or Off.

If "Bus" is set to IFX1–IFX5, the send levels to master effects 1 and 2 are set by "Send 1" and "Send 2" after passing through IFX1–5.

OSC1 Send2 [000...127]

Sets the volume (send level) at which the output of oscillator 1 will be sent to master effect 2. (☞ "OSC1 Send1")

OSC2 Send1 [000...127]

OSC2 Send2 [000...127]

Sets the volume (send level) at which the output of OSC2 will be sent to master effects 1 and 2. These parameters will be valid when program used two oscillators and "Bus" is set to L/R or Off.

MIDI CC#93 controls OSC 1/2's Send 1 level, and CC#91 controls the Send 2 level. These are controlled on the global MIDI Channel ☞ p.60. The actual send level is determined by multiplying these values with the send levels of each oscillator.

IFX1, IFX2, IFX3, IFX4, IFX5

Here you can adjust settings for the insert effects. These consist mainly of the following.

- Select the effect type for each insert effect 1–5, and set the effect parameters.
- Turn each insert effect 1–5 on/off.
- Specify how the insert effects are connected, and adjust mixer settings for the signals that have passed through the insert effects.

For the insert effects, the direct (Dry) sound will always be stereo-input/output. The input/output structure of the effect (Wet) sound will depend on the type of effect (☞ p.208).

IFX1

Here you can edit the effect parameters for insert effect 1.

IFX Select [S00...S63, D00...D10]

This selects the effect type for insert effect 1.

S00–S63 are single-size and D00–D10 are double-size effects.

⚠ If you use a double-size effect, the next insert effect will be unavailable. For example if you select a double-size effect for IFX1, you won't be able to use IFX2.

IFX Parameters

Here you can set the parameters for the effect that's selected by "IFX Select." For details on the effect parameters, please refer to "Effect Guide" (☞ p.217).

Principal effect parameters can be edited from the microSTATION itself. To edit all parameters, you'll need to use the editor.

On/Off [Off, On]

Switches the insert effect on/off.

If this is off, the input will simply be passed to the output. (When 000:No Effect is selected, there's no difference between On and Off.)

MIDI Separately from this setting, you can use MIDI CC #92 (on the global MIDI Channel ☞ p.60) to turn all insert effects off. A value of 0 turns them off, and values of 1–127 restore the original setting.

Chain [Off, On]

This connects insert effects in series.

If "Chain" is On, this insert effect will be connected in series with the insert effect selected by "ChainTo."

With the On setting, the upper line of the display shows the insert effect connection status.

Screen when insert effects 1–5 are all connected

```
<IFX1[1+2+3+4+5]
  *S01: St. Comp >
```

Example: IFX1 “ChainTo”: IFX2
IFX1 “Chain”: On

Insert effects 1 and 2 will be connected in series. If “Bus” is set to IFX1, the oscillator’s output will be sent in series through IFX1 → IFX2. You can connect up to five insert effects (IFX1–IFX5) in series. In this case, the “Pan (CC#8),” “Bus,” “FxCtrl Bus,” “Send1,” and “Send2” settings following the last insert effect will be used.

ChainTo [IFX2...IFX5]

This selects the connection-destination insert effect.

 If you’ve selected a double-size effect, you must use caution when specifying the connection-destination. For example if you’ve chained IFX1→IFX2, the connection will be cancelled if you select a double-size effect for “IFX1.” Use “ChainTo” to specify a connection to the following effect.

Pan (CC#8) (Post IFX PanCC#8) [L000...C064...R127]

Specifies the panning immediately after the insert effect.

 You can use CC#8 to control this.

Bus (Bus Select) [Off, L/R]

Specifies the bus where the signal will be sent immediately after the insert effect.

L/R: The signal will be sent to the L/R bus, which passes through TFX and then goes to the OUTPUT L/R outputs. This is the default setting.

Off: The signal will not be sent directly to the L/R outputs. This setting is useful if you want to:

Use Send 1 or 2 to route the signal entirely through the master effects, without sending the dry signal to the outputs.

Use the FX Control Bus to route the signal to an effects side-chain, such as a gate or vocoder, without being heard directly at the outputs.

FXCtrl Bus (FX Control Bus) [Off, 1, 2]

Sends the post-IFX signal to the FX Control busses.

For more information, please see “FX Control Bus” on page 207.

 If you’re using “Ctrl” (FX Control Bus) as an input signal for double size effect D9: Vocoder etc., a feedback loop will occur if you output to the same bus as specified here, and oscillation will occur. Set this with care to avoid creating a loop.

Send1 [000...127]

Send2 [000...127]

These adjust the level at which the post-IFX signal is sent to master effects 1 and 2. This is valid if “Bus” is set to L/R or Off.

 You can use CC#93 to control the Send 1 level, and CC#91 to control the Send 2 level. The global MIDI channel specified by MIDI Channel (p.60) is used for these messages.

IFX2, IFX3, IFX4

Here you can edit the effect parameters for insert effects 2, 3, and 4.

IFX Select [S00...S61, D00...D09]

This selects the effect type for insert effect.

S00–S61 are single-size and D00–D09 are double-size effects.

IFX Parameters

Here you can set the parameters for the effect that’s selected by “IFX Select.” For details on the effect parameters, please refer to “Effect Guide” (p.217).

On/Off [Off, On]

This turns the insert effect on and off.

See “On/Off” on page 11.

ChainTo [IFX3...IFX5]

This selects the connection-destination insert effect.

Insert effect 2 can be connected to IFX3–IFX5.

Insert effect 3 can be connected to IFX4–IFX5.

Insert effect 4 does not provide a “ChainTo” setting. It can be connected only to insert effect 5.

See “ChainTo” on page 12.

Chain [Off, On]

Pan (CC#8) (Post IFX PanCC#8) [L000...C064...R127]

Bus (Bus Select) [Off, L/R]

FXCtrl Bus (FX Control Bus) [Off, 1, 2]

Send1 [000...127]

Send2 [000...127]

See “IFX1” on page 11.

IFX5

Here you can edit the effect parameters for insert effect 5.

 You can’t connect from insert effect 5 to another insert effect.

IFX Select [S00...S61]

This selects the effect type for insert effect.

IFX5 cannot use double-size effects (154–170).

IFX Parameters

Here you can set the parameters for the effect that’s selected by “IFX Select.” For details on the effect parameters, please refer to “Effect Guide” (p.217).

On/Off [Off, On]

This turns the insert effect on and off.

See “On/Off” on page 11.

Pan (CC#8) (Post IFX PanCC#8) [L000...C064...R127]

Bus (Bus Select) [Off, L/R]

FXCtrl Bus (FX Control Bus) [Off, 1, 2]

Send1 [000...127]

Send2 [000...127]

See “IFX1” on page 11.

MFX1, MFX2

Here you can adjust settings for the master effects. These consist mainly of the following.

- Select the effect type for each master effect, and set the effect parameters.
- Turn each master effect on/off.
- Specify how the master effects are connected, and specify the level at which the signal from the effects are returned to the L/R bus.

The master effects do not output direct (Dry) sound. The return levels “Return1” and “Return2” return the effect (Wet) sound to the L/R bus and mix the signal into the L/R bus.

Although the master effect input/outputs are stereo-in/stereo-out, but the output may be monaural depending on the type of effect that is selected. (☞ “In/Out” on page 208)

MFX1

MFX Select [S00...S87, D00...D13]

This selects the effect type for master effect 1.

S00–S87 are single-size and D00–D13 are double-size effects.

If you choose S00: No Effect, the output from the master effect will be muted.

MFX Parameters

Here you can set the parameters for the effect that’s selected by “MFX Select.”

For details on the effect parameters, please refer to “Effect Guide” (☞ p.217).

On/Off [Off, On]

Switches the master effect 1 on/off. When off, the output will be muted.

 Separately from the settings here, you can use control change #94 to turn master effects 1 and 2 off. A value of 0 turns them off, and values of 1–127 restore the original setting. The global MIDI channel specified by MIDI Channel (☞ p.60) is used for this message.

Return 1 [000...127]

This specifies the return level from the master effect to the L/R bus (after which it passes through TFX, and is sent from OUTPUT L/MONO and R).

Chain [Off, On]

On: Master effects 1 and 2 will be connected in series, in the order of master effect 1 → master effect 2.

ChainLevel [000...127]

When “Chain On/Off” is On, this specifies the level of the signal sent from master effect 1 to master effect 2.

 If you’re using a double-size effect, the “Chain” settings will be unavailable.

MFX2

MFX Select [000...120]

This selects the effect type for master effect 2.

For master effect 2, only 000–120 single-size effects can be selected.

 MFX2 cannot use double-size effects. Additionally, if you select a double-size effect for MFX1, you won’t be able to use MFX2.

If you choose S00: No Effect, the output from the master effect will be muted.

MFX Parameters

Here you can set the parameters for the effect that’s selected by “MFX Select.” For details on the effect parameters, please refer to “Effect Guide” (☞ p.217).

On/Off [Off, On]

Switches the master effect 2 on/off. When off, the output will be muted.

Return 2 [000...127]

These parameters specify the effect type for master effect 2, its on/off status, and the return level from master effect 2 to the L/R bus.

For more information, please see “Return 1.”

TFX

Here you can adjust settings for the total effect, which is located at the final stage of the L/R bus. These consist mainly of the following.

- Select the effect type for the total effect, and set the effect parameters.
- Turn the total effect on/off.

For the total effect, the direct (Dry) sound will always be stereo-in/stereo-out. The input/output configuration of the effect (Wet) sound will depend on the effect type.

Although the total effect’s input/output is stereo-in/stereo-out, the output may be monaural depending on the type of effect that is selected. (☞ “In/Out” on page 208)

After the signal has passed through the total effect, it is output from OUTPUT L/MONO and R.

TFX

TFX Select [S00...S61]

This selects the effect type for total effect.

 TFX cannot use double-size effects.

TFX Parameters

Here you can set the parameters for the effect that’s selected by “TFX Select.”

For details on the effect parameters, please refer to “Effect Guide” (☞ p.217).

On/Off [Off, On]

This turns total effect on/off. If this is off, the input will be passed directly through.

 Alternatively, you can send control change #95 to turn the total effect off. A value of 0 turns the total effect off, and values of 1–127 restore the original setting. The global MIDI channel specified by MIDI Channel (☞ p.60) is used for this message.

Master Vol

Master Vol (Master Volume) [000...127]

This specifies the final level of the audio output that has passed through total effect, and output from OUTPUT L/MONO and R.

Command

These commands allow you to do things such as copying arpeggiator or effect settings. Specify the copy-source and copy-destination, get the "OK?" prompt, and then press the ► button to begin.

For copy-related commands, please note the following points when using "From" and "Src" to specify the copy-source.

- If you specify Program or Combi in "From," the "Src" field will show a bank number such as "A000." This indication matches the bank number shown in the upper right of the display when you turn NUMLOCK on in PROG PLAY or COMBI PLAY and press the function 14 (ENTER) button.
- If you specify Song in "From," the "Src" field will show a song number. In this case, you can choose only song numbers that are loaded into the microSTATION or that you created on the microSTATION.

Copy Arpeggio

This command copies arpeggio settings.

From [Program, Combi, Song]

Select the copy-source mode.

Src (Source) [A000: name..., 000: name...]

Select the copy-source.

Src's [A, B, A&B]

If you select a combination or song as the copy-source, this specifies whether you'll be copying the settings of arpeggiator A or B.

To [A, B]

Specify the copy-destination arpeggiator. This is not shown if "Src's" is set to A&B.

Copy IFX

This command copies the insert effect settings of a desired program, combination, or song. The following settings will be copied.

- All settings of the insert effect (the contents of the IFX page and the effect parameters, except for "Ctrl Ch").
- The "Pan (CC#8)," "Bus," "FX Ctrl," "Send1," and "Send2" settings that follow the insert effect.

From [Program, Combi, Song]

Select the copy-source mode.

Src (Source) [A000: name..., 000: name...]

Select the copy-source.

Src's [All IFXs, IFX1...IFX5]

Select the effect that you want to copy.

If you select All IFXs, the settings of all insert effects will be copied.

To [IFX1...IFX5]

Specify the copy-destination insert effect.

This is not shown if "Src's" is set to All IFXs.

Swap IFX

This command exchanges the settings of two insert effects.

Source1 [IFX1...IFX5]

Source2 [IFX1...IFX5]

Select the two insert effects whose settings will be exchanged.

Copy MFX/TFX

This command copies effect settings from a specified program, combination, or song to a master effect or to the total effect.

▲ "Master Volume" settings will not be copied.

From [Program, Combi, Song]

Select the copy-source mode.

Src (Source) [A000: name..., 000: name...]

Select the copy-source.

Src's [M1,2&TFX, IFX1...IFX5, MFX1, MFX2, TFX]

Select the effect that you want to copy.

If you select IFX1-IFX5, settings will be copied from the corresponding insert effect. When copying from an insert effect, the result will not be completely identical because of differences in the routing and the level settings.

If you select MFX1 or MFX2, the "Return" (return level) setting will also be copied.

To [IFX1...IFX5, MFX1, MFX2, TFX]

Specify the copy-destination master effect or total effect.

This is not shown if "Src's" is set to M1,2&TFX.

Write Program

This saves the edited program to the microSTATION's memory. You can use this to do the following.

- Save the edited content.
- Rename a program.
- Specify the program's category.
- Copy a program to a different bank or program number.

▲ Be sure to save important programs. An edited program cannot be recovered if you turn off the power or select a different program before you've saved it.

▲ Before you can write, you must turn off memory protect in Global mode.

Name [space, !...~]

Specify the program name. Use the ◀▶ buttons to select a character, and use the ▲▼ buttons to change the character. You can enter up to twenty-four characters.

Cat (Category) [KEYBOARD...USER]

Select the category for the program you're saving.

The category you specify here can be used when selecting programs by category in Program, Combination, or Sequencer modes.

To [A000...D127: name]

Specify the save-destination for the program. The microSTATION allows you to save 512 programs.

The save-destination is indicated by bank number. This bank number matches the bank number shown in the upper

right of the display when you turn NUMLOCK on in PROG PLAY and press the function 14 (ENTER) button. You can specify A000–D127; the GM2 bank is not available for saving.

Note: Programs on the microSTATION are internally managed by bank and number. The saved program will be written to a bank number A000–D127.

OK?

Press the ► button to save the data.

Note: You can also save the program by pressing the WRITE button. When you press the WRITE button, a confirmation screen of “OK” will appear. When you do this, the program will be saved by overwriting the currently selected program.

External Setup

You can use the microSTATION’s external control functionality to control an external MIDI device; press the EXTERNAL button and use knobs 1–4 to transmit MIDI control change messages on the specified MIDI channel.

Setup Select [000...127: name]

This selects the setup that will be used for external control. You can choose from 128 setups.

Preload setup data is loaded when the microSTATION is shipped from the factory. For example, these setups include a setup that let you control the Korg Legacy Collection of software synthesizers, and a setup that lets you control DAW software. (☞“microSTATION External Setup (PDF)”)

You can use Global/Media: MIDI - External Setup to assign the function of each knob in an external setup(☞“External Setup” on page 64).

- | | |
|----------|---------------------------------------|
| 1 | [MIDI Ch/MIDI CC#: Knob value] |
| 2 | [MIDI Ch/MIDI CC#: Knob value] |
| 3 | [MIDI Ch/MIDI CC#: Knob value] |
| 4 | [MIDI Ch/MIDI CC#: Knob value] |

These indicate the assignments for knobs 1–4 in the selected external setup. From the left, these are the MIDI channel / MIDI control change / current knob value. The knob value can be edited.

Combination mode

You'll use Combination mode to play combinations. This mode lets you do the following things.

- Select and play combinations.
- Select each timbre's program, and edit its volume and other parameters.
- Use the Realtime Control knobs to control the combination's sounds and arpeggiator.

Page structure in Combination mode

The microSTATION's Combination mode is organized as a tree structure containing the following pages. (p.18)

For details on how to move between pages, and how to select parameters and edit their values, please refer to the "microSTATION Operation Guide."

COMBI PLAY

In COMBI PLAY you can select and play combinations. You can also use the Realtime Control knobs to control the combination's sounds and arpeggiator while you perform.

Tips: Auto Song Setup

The Auto Song Setup function automatically converts the settings of a program or combination into a song, and puts the microSTATION in record-ready condition. This function seamlessly unifies program or combination performance with song production; if you get an idea for a phrase or song while playing the arpeggiator, you can instantly turn your idea into a song.

Combination No.&Name

[001...: combination name]

This indicates the combination that's currently selected.

In the microSTATION's Combination mode, the 256 preload combinations are organized into the following seven categories.

Category	Explanation
All	No category. All 383 combinations can be selected. 001...128: A000...A127 129...256: B000...B127 257...384: C000...C127
KEYBOARD	A.Piano, Synth E.P, Real E.P, Clav/Harpsi, E.Organ, Pipe.Organ
STRINGS/BRASS/ WOODWIND	Orchestral, World, Strings, Vocal, Airy, Brass, Woodwind, Reed
GIUITAR	A.Guitar, E.Guitar, Plucked
BASS&BASS SPLIT	Bass Split, Bass
SYNTH	Fast, Slow, Motion, Short decay
LEAD&SOLO SPLIT	Solo Split, Syn Lead
DRUM/MALLET/ HITS	Natural, Dance, Perc, Bell, Mallet, SFX, Hits
USER	Sounds saved as a user category (none in factory settings)

Note: In COMBI PLAY if you turn NUMLOCK on (LED lit) and press the function 14 (ENTER) button, the bank and number will be shown in the right side of the display's upper line. For example when you've set the category to ALL, this indication lets you view the combinations by bank number rather than by number within a category.

EXTERNAL control

In COMBI PLAY, if you press the EXTERNAL button to turn External Control on, and then operate knobs 1-4, the display will briefly show the MIDI channel, MIDI CC number and value that are assigned by the selected external setup. External setups can be selected in COMBI EDIT: External Setup. (p."External Setup" on page 28)

 If the MIDI CC number for a knob is turned Off in the selected external setup, then the value will not appear when you operate the knob.

COMBI EDIT

Here you can edit the microSTATION's combination quick parameters. The quick parameters are parameters that can be edited from the microSTATION itself. These consist of the following.

- Volume, pitch, and note range settings for each timbre.
- Adjustments to the sound of the program used by each timbre.
- MIDI filter and controller settings.
- Arpeggiator settings used by the combination.
- Each timbre's routing, and settings for the insert effects, master effects, and total effect.

If you want to edit all parameters of the combination, you'll need to use microSTATION Editor/Plug-In Editor on a connected computer.

Timbre (Timbre Parameters)

Here are the settings for the timbres of the combination.

Timbre 01

Program Select

[001...: program name]

Select the program used by the timbre.

The number and program name are shown. The category is shown by the CATEGORY indicator located at the left of the display.

Note: When the front panel TIMBRE/TRACK LED is lit, you can press a function button 01-16 in the COMBI PLAY screen to access the "Program Select" display for the timbre of the corresponding number.

Switching a timbre's program

- Use the CATEGORY SELECT buttons to select a category, and the ▲▼ buttons to select a program.
- Use the CATEGORY SELECT buttons to select a category, press the NUM LOCK button (making it light) to select the num-lock state, use function buttons 01-10 to enter a program number, and press the 14 (ENTER) button.
- Transmit a MIDI program change from a connected external MIDI device.
See "Program Select" on page 141.

COMBI PLAY ◀▶ COMBI EDIT

Timbres ◀▶

- Timbre 01** (≡ p.17) ◀▶
 - Program Select
 - Volume
 - Pan
 - Mute/Play
 - Solo
 - Bus
 - Drumkit IFX Patch ◀▶
 - IFX1
 - IFX2
 - IFX3
 - IFX4
 - IFX5
 - FXCtrlBus
 - ARP Assign
 - Status
 - MIDI Ch.
 - OSC Mode
 - Portamnto
 - Transpose
 - Detune
 - Bend Range
 - Filter/Amp (≡ p.21) ◀▶
 - Cutoff
 - Resonance
 - Flt EG Int
 - AmpVel Int
 - Filter/Amp EG (≡ p.21) ◀▶
 - Attack
 - Decay
 - Sustain
 - Release
 - Key Zone (≡ p.21) ◀▶
 - Top
 - Top Slope
 - Btm Slope
 - Bottom
 - Vel Zone (≡ p.22) ◀▶
 - Top
 - Top Slope
 - Btm Slope
 - Bottom
 - MIDI Filter (≡ p.22) ◀▶
 - Prog Chg
 - Damper
 - JS X as AMS
 - JS+Y
 - JS-Y
 - Knob 1-A
 - Knob 2-A
 - Knob 3-A
 - Knob 4-A
 - Knob 1-B
 - Knob 2-B
 - Knob 3-B
 - Knob 4-B
 - FootSwitch
 - FootPedal
- Timbre02**
 - Same as Timbre01 parameters
 -
 -
- Timbre16**
 - Same as Timbre01 parameters

Knob Assign (≡ p.23) ◀▶

- Knob 1B
- Knob 2B
- Knob 3B
- Knob 4B
- Tempo** (≡ p.23) ◀▶
 - Tempo
- ARP** (≡ p.23) ◀▶
 - ARP-A Setup** (≡ p.23) ◀▶
 - Run
 - Pattern
 - Octave
 - Resolution
 - Gate[%]
 - Velocity
 - Swing[%]
 - Sort
 - Latch
 - KeySync
 - Keyboard
 - BottomKey
 - Top Vel
 - BottomVel
 - ARP-B Setup** ◀▶
 - Same as ARP A parameters
- IFX1** (≡ p.25) ◀▶
 - S01: St. Comp ◀▶
 - Wet/Dry :32:68
 - :
 - :
 - :
 - FXParam
 - On/Off
 - Chain
 - ChainTo
 - Pan(CC#8)
 - Bus
 - FX Ctrl
 - Send1
 - Send2
- IFX2** (≡ p.25) ◀▶
 - Same as IFX1 parameters
- IFX3** (≡ p.25) ◀▶
 - Same as IFX1 parameters
- IFX4** (≡ p.25) ◀▶
 - Same as IFX1 parameters
- IFX5** (≡ p.25) ◀▶
 - S01: St. Comp ◀▶
 - Wet/Dry :32:68
 - :
 - :
 - :
 - FXParam
 - On/Off
 - Pan(CC#8)
 - Bus
 - FX Ctrl
 - Send1
 - Send2
- MFX1** (≡ p.26) ◀▶
 - S01: St. Comp ◀▶
 - Wet/Dry :32:68
 - :
 - :
 - :
 - FXParam
 - On/Off
 - Ctrl Ch
 - Return1
 - Chain
 - Chain Level

MFX2 (≡ p.26) ◀▶

- S01: St. Comp ◀▶
 - Wet/Dry :32:68
 - :
 - :
 - :
 - FXParam
- On/Off
- Ctrl Ch
- Return2
- TFX** (≡ p.26) ◀▶
 - S01: St. Comp ◀▶
 - Wet/Dry :32:68
 - :
 - :
 - :
 - FXParam
 - On/Off
- MasterVol** (≡ p.26) ◀▶
 - Master Vol
- Command** (≡ p.27) ◀▶
 - Copy ARP
 - Copy IFX
 - Swap IFX
 - Copy MFX/TFX
 - Initialize
 - Copy Prog
- Write Combi** (≡ p.28)
- External Setup** (≡ p.28) ◀▶
 - 001: External
 - 1. Gch/#001: 000
 - 2. Gch/#002: 000
 - 3. Gch/#003: 000
 - 4. Gch/#004: 000

Volume [000...127]

Adjusts the volume of each timbres. (☞ "Volume" on page 142)

Tips: When the front panel TIMBRE/TRACK LED is lit, you can press a function button 01–16 to view and edit the parameters of the correspondingly-numbered timbre in the display.

Pan [RND, L001...C064...R127]

This specifies the pan of each timbre.

L001...C064...R127: A setting of L001 is far left and R127 is far right. A setting of C064 will reproduce the pan setting of the Program mode. (☞ "Pan" on page 141)

Play/Mute [Play, Mute]

This setting mutes a timbre.

Play: The timbre will produce sound.

Mute: The timbre will be muted (silent).

Bus (Bus Select) [DKit, L/R, IFX1...IFX5, Off]

L/R: Output to the L/R bus.

IFX1...IFX5: Output to the IFX1–IFX5 buses.

Off: The timbre will not be output from the L/R bus, or IFX1–IF5 buses. Choose the Off setting if you want the program oscillator output of the timbre to be connected in series to a master effect. Use "OSC1 Send1," "OSC1 Send2," "OSC2 Send1," and "OSC2 Send2" to specify the send levels.

DKit: This can be selected only if the timbre's program is a drum program. The "Bus," "FXCtrl Bus," "Send1," and "Send2" settings for each key of the selected Dkit will be used. Select this setting if you want to apply an individual insert effect to each drum instrument.

Note: In most preloaded drumkits, the drum instruments have the same Bus (IFX/Output) Select settings according to their type, as follows.

Snares → IFX1

Kicks → IFX2

Other → IFX3

If you want to edit these routings, use the "DKit Patch."

DrumKit Patch

This lets you patch the bus select setting for each key of a drum kit, temporarily changing the connection destinations to the insert effects.

These settings are available if the program used by the timbre is a drum program and "Bus" (☞ p.19) is set to DKit.

 These settings are available if the bus select setting of a drum kit is set to any insert effect IFX1–IFX5.

Bus IFX1 [L/R, IFX1...IFX5, Off]

Bus IFX2 [L/R, IFX1...IFX5, Off]

Bus IFX3 [L/R, IFX1...IFX5, Off]

Bus IFX4 [L/R, IFX1...IFX5, Off]

Bus IFX5 [L/R, IFX1...IFX5, Off]

Choose insert effect 1–5, L/R, or Off as the patch-destination of the insert effect.

If you want to return to the settings of the drum kit, set these parameters to IFX1: IFX1, IFX2: IFX2, IFX3: IFX3, IFX4: IFX4, and IFX5: IFX5.

FXCtrl Bus (FX Control Bus) [Off, 1, 2]

Sends the output of the timbre to an FX Control bus (two-channel mono FX Ctrl 1 or 2).

Use the FX Control buses when you want a separate sound to control the audio input of an effect. You can use two FX

Control buses (each is a two-channel mono bus) to control effects in various ways. (☞ "FX Control Bus" on page 207)

Send1 [000...127]

Send2 [000...127]

For each timbre, these parameters set the send level to master effects 1 and 2. These settings are valid when "Bus" is set to L/R or Off.

In the case of IFX1–IFX5, the IFX1–5 page settings "Send1" and "Send2" after the signal has passed through IFX1–IFX5 will specify the send levels to master effects 1 and 2.

 Control change CC#93 can be used to control the Send 1 level, and CC#91 to control the Send 2, and modify their respective settings. These messages will be received on the MIDI channel (☞ p.20) specified for each timbre.

The actual send levels are determined by multiplying this value with the send level Send1 and Send2 (☞ p.11) for each oscillator of the program selected for the timbre.

ARP Assign [Off, A, B]

Assigns arpeggiator A or B to each timbres. When the ARP ON/OFF button is on, the arpeggiator specified for each timbre will operate according to "Arpeggiator Run A, B" and these settings.

Off: The arpeggiator will not operate.

A: Arpeggiator A will operate. Use the settings in the Arp-A Setup page to select the arpeggio pattern and to set parameters.

B: Arpeggiator B will operate. Use the settings in the Arp-B Setup page to select the arpeggio pattern and to set parameters.

 If the Status (☞ p.20) of the timbre is INT, each timbre 1–16 will be sounded by the note data generated by the assigned arpeggiator, regardless of the MIDI Channel (☞ p.20) setting of the timbre.

If a timbre is set to EXT or EX2, MIDI note data will be transmitted on the "MIDI Ch." of that timbre.

In this case, arpeggiator A (or B) will be triggered (operated) by all MIDI channels specified for the MIDI Channel parameter of any timbre 1–16 assigned to arpeggiator A or B.

 If Local Control (Local Control On, ☞ p.61) is OFF, the keyboard will not trigger the arpeggiator. The arpeggiator will be triggered via MIDI IN. Turn Local Control OFF if you have recorded only the trigger notes on an external sequencer, and wish to playback the external sequencer to trigger the microSTATION's arpeggiator.

 If you want to record the note data generated by the arpeggiator to an external sequencer, turn Local Control ON, and turn off the echo back function on your external sequencer.

You can control the arpeggiator from an external sequencer, or use an external sequencer to record arpeggio note data. (☞ p.311)

Example 1)

Set the MIDI Channel (☞ p.20) of timbres 1 and 2 to Gch, and set Status (☞ p.20) to INT. Assign arpeggiator A to timbre 1 and arpeggiator B to timbre 2, and Arpeggiator A, B "Run" (☞ p.23) is turn on.

- When the ARP ON/OFF button is off, timbres 1 and 2 will sound simultaneously (layered) when you play the keyboard.
- When the ARP ON/OFF button is turned on, timbre 1 will be played by arpeggiator A, and timbre 2 will be played by arpeggiator B.

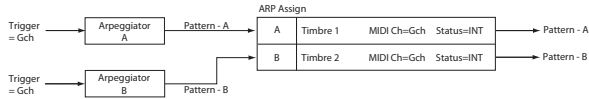

Example 2)

The MIDI Channel (p.20) of timbres 1, 2, 3, 4, and 5 are set respectively to Gch, Gch, 02, Gch, and 03. Their Status (p.20) is set respectively to INT, Off, INT, Off, and INT. Assign arpeggiator A to timbres 2 and 3, assign arpeggiator B to timbres 4 and 5, and Arpeggiator A, B “Run” (p.23) is turn on.

- When the ARP ON/OFF button is off, playing the keyboard will sound only timbre 1. (Timbres 2 and 4 are receiving the Gch, but they will not sound since their “Status” is Off.)
- When you turn on the ARP ON/OFF button, arpeggiator A will play timbres 2 and 3, and arpeggiator B will independently play timbres 4 and 5. (Arpeggiators A and B are triggered by note data received from any MIDI channel of an assigned timbre. However, in this example, they are being triggered from the Gch.)

When you play the keyboard, arpeggiator A will play timbres 2 and 3, but only timbre 3, whose “Status” is INT will sound from the keyboard. Similarly, arpeggiator B will play timbres 4 and 5, but only timbre 5, whose “Status” is INT will sound from the keyboard.

In this way, you can adjust settings so that a timbre is silent when the arpeggiator is off, and sounds only when the arpeggiator is on.

This type of setting is used in preloaded combinations which sound the drums only when the arpeggiator is on.

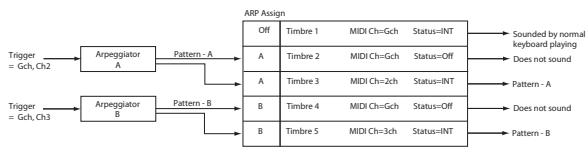

Status [Off, INT, EXT, EX2]

This parameter sets whether the Timbre controls the internal sounds, or external MIDI devices.

Off: Use this to disable the Timbre. With this setting, the Timbre’s Program will not sound, and MIDI data will not be transmitted.

INT: The timbre will sound, and will also sound in response to MIDI messages from an external MIDI device. MIDI data will not be transmitted.

EXT: The timbre will not sound even if it receives messages from a controller, but MIDI data will be transmitted to external devices.

EX2: The “Bank Select (When Status=EX2)” (settable only via the editor, p.145) LSB value and MSB value will be used. Instead of the A-g(d) bank numbers that can be selected from the microSTATION itself, the bank number specified for “Bank Select” will be transmitted via MIDI. Other aspects are the same as for EXT.

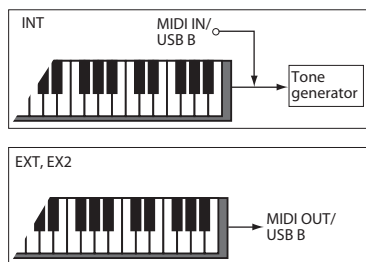

MIDI Ch. (MIDI Channel) [01...16, Gch]

This parameter allows you to sets the MIDI transmit/receive channel for each timbre.

Gch: The timbre will use the channel that has been selected as the global MIDI Channel (p.60).

When Status is INT, MIDI messages will be received on the channel that you specify here. If this setting is the same as the global MIDI channel, the internal tone generator will sound according to the internal settings. If this is set to EXT or EX2, playing the microSTATION will transmit MIDI messages on the MIDI channel that’s specified here. (Messages will also be transmitted simultaneously on the global MIDI channel.)

If a setting 01–16 matches the global MIDI channel, “G” is shown at the right.

OSC Mode [PRG, Poly, Mono, Legt]

This lets you override the Program’s stored Voice Assign Mode settings, if desired.

PRG: The Program’s stored “VoiceMode” (p.3) settings will be used.

Poly: The timbre will play polyphonically, regardless of the Program’s settings.

Mono: The timbre will play monophonically, regardless of the Program’s settings.

Legt (Legato): The timbre will sound monophonically, and will play legato according to the Program’s setting.

With the MN or LGT settings, the Program’s setting will determine the priority of the note that sounds when you play two or more notes.

Portamento (Portamento) [PRG, Off, 001...127]

This parameter allows you to select portamento settings for each timbre. (“Portamento” on page 146)

PRG: Portamento will be applied as specified by the program settings.

Off: Portamento will be off, even if the original program settings specified Portamento to be on.

001...127: Portamento will be applied with the portamento time you specify here, even if it is turned off by the program settings.

Transpose [-60...+00...+60]

This parameter adjusts the pitch of each timbre in semitone steps. 12 units equal one octave. (“Transpose” on page 147)

Detune [-1200...+0000...+1200]

This parameter adjusts the pitch of each timbre in one-cent units. (“Detune” on page 147)

+0000: Standard pitch. A setting of +0100 produces the same pitch as “Transpose” +01.

Bend Range [PRG, -24...+00...+24]

Specifies the maximum amount of pitch change (in semitones) that will occur when the pitch bender is used. (“Bend Range” on page 147)

PRG: The pitch range specified by the program will be used.

-24...+24: This setting will be used regardless of the setting in the program.

Tone parameters

The Program mode tone parameters in the Filter/Amp through Filter/Amp EG groups can be edited individually for each timbre.

These parameters are Relative parameters. They apply an adjustment that is relative to the setting specified by the program parameters.

The relative adjustment is saved in the combination, and does not affect the original program.

MIDI Some parameters in these groups are interrelated with control of certain MIDI CC messages. For these, an indication such as "CC#74" appears following the parameter value.
(☞ "About the Tone parameters" on page 149)

Filter/Amp

Here you can adjust settings for the filter and amp of the program for each of the timbres.

Cutoff (Filter Cutoff) [-99...+99 (Rel, CC#74)]

This scales the cutoff frequency of all of the filters at once. It affects both Filters A and B.

Resonance (Filter Resonance) [-99...+99 (Rel, CC#71)]

This scales the resonance of all of the filters at once. It affects both Filters A and B.

Filt EG Int (Filter EG Intensity) [-99...+99 (Rel, CC#79)]

This scales the effect of the Filter EG on the cutoff frequency. It affects Filters A and B simultaneously.

-99 means no modulation. +99 means maximum. Modulation is in the same direction, positive or negative, as the original Program. For instance, if the original Program's "EG Intensity" was set to -25, then setting this parameter to +99 moves the "EG Intensity" to -99.

AmpVel Int (Amp Velocity Intensity) [-99...+99 (Rel)]

This scales the effect of velocity on the Amp level. -99 removes the velocity modulation entirely. +99 means maximum modulation in the same direction, positive or negative, as the original Program.

Filter/Amp EG

Here you can adjust settings for the filter EG and amp EG of the program for each of the timbres.

Attack (Filter/Amp EG Attack Time) [-99...+99 (Rel, CC#73)]

This scales the attack times of the Filter and Amp EGs, along with other related parameters.

When the value is +1 or more, this also affects the Amp EG's Start and Attack Levels, Start Level AMS, and Attack Time AMS.

Between values of +1 and +25, the Start Level, Start Level AMS, and Attack Time AMS will change from their programmed values to 0. Over the same range, the Attack Level will change from its programmed value to 99. ("AMS (Alternate Modulation Source)" ☞ p.91)

Decay (Filter/Amp EG Decay Time) [-99...+99 (Rel, CC#75)]

This scales the decay and slope times of the Filter and Amp EGs.

Sustain (Filter/Amp EG Sustain Level) [-99...+99 (Rel, CC#70)]

This scales the sustain levels of the Filter and Amp EGs.

Release (Filter/Amp EG Release Time) [-99...+99 (Rel, CC#72)]

This scales the release times of the Filter and Amp EGs.

Key Zone

These settings specify the keyboard range in which timbres 1-16 will sound.

The top/bottom key parameters specify the range of notes in which timbres 1-16 will sound, and the top/bottom slope parameters specify the range over which the original volume will be reached.

Key Split: By setting timbres of different sounds to ranges that do not overlap, you can play different sounds in different ranges of the keyboard.

Layer: By setting the ranges to overlap, you can play two or more sounds with a single note.

Positional Cross-fade: If you set the slopes (the grayed portion) to overlap, the sounds will overlap, and the proportion of the overlap will change according to the keyboard location.

Top (Top Key) [C-1...G9]

Specifies the top key (upper limit) of the notes that will sound each timbres.

Top Slope [00, 01, 02, 03, 04, 06, 08, 10, 12, 18, 24, 30, 36, 48, 60, 72]

Specifies the range of keys (12 is one octave) over which the volume will be reached starting from the top key.

0: The volume will be at the original level from the top key.

12: The volume will increase gradually as you play downward, and will reach the original volume one octave below the top key.

72: The volume will increase gradually as you play downward, and will reach the original volume six octaves below the top key.

Btm Slope [00, 01, 02, 03, 04, 06, 08, 10, 12, 18, 24, 30, 36, 48, 60, 72]

Specifies the range of keys (12 is one octave) over which the volume will be reached starting from the bottom key.

0: The volume will be at the original level from the bottom key.

12: The volume will increase gradually as you play upward, and will reach the original volume one octave above the bottom key.

72: The volume will increase gradually as you play upward, and will reach the original volume six octaves above the bottom key.

Bottom (Bottom Key) [C-1...G9]

Specifies the bottom key (lower limit) of the notes that will sound each timbre.

How volume will change according to keyboard location

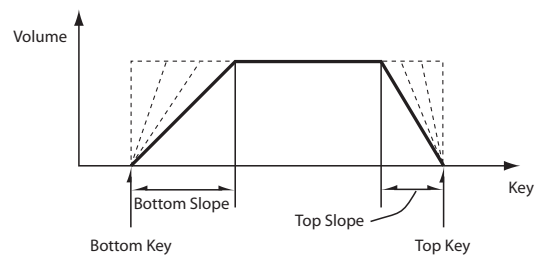

Top Key and Bottom Key settings can also be input by holding down the KEY button and playing a note on the keyboard.

It is not possible to set the bottom key above the top key of the same timbre. Nor is it possible for the top and bottom slopes to overlap.

Vel Zone (Velocity Zone)

Sets the Top/Bottom Velocity parameters to specify the range of velocities that will sound for each timbres, and set the Top/Bottom Slope parameters to specify the range over which the volume will change.

Velocity switch: If you set different velocity zones for multiple timbres so that they do not sound together, you can play separate sounds by varying playing dynamics.

Layer: If you set two or more timbres to velocity zones that overlap, the sounds will be heard together.

Velocity Cross-fade: If the slope ranges overlap, different sounds will be sounded together, and your playing dynamics will determine the proportion of each sound.

It is not possible to set the bottom velocity greater than the top velocity for the same timbre, nor can the top slope and the bottom slope overlap.

Top (Top Velocity) [001...127]

Specifies the maximum velocity value that will sound each timbre.

Top Slope [000...120]

Specifies the number of velocity steps over which the original volume will be reached, starting from the Top Velocity.

000: The volume will be at the original value from the top velocity.

120: The volume will decrease as the velocity approaches the top velocity.

Btm Slope [000...120]

Specifies the number of velocity steps over which the original volume will be reached, starting from the Bottom Velocity.

000: The volume will be at the original value from the bottom velocity.

120: The volume will decrease as the velocity approaches the bottom velocity.

Bottom (Bottom Velocity) [001...127]

Specifies the minimum velocity value that will sound each timbre.

How volume will change according to keyboard location

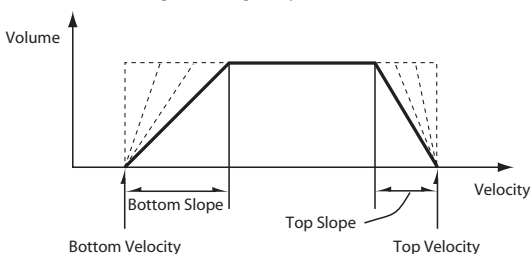

Top Velocity and Bottom Velocity settings can also be input by holding down the KEY button and playing a note on the keyboard.

MIDI Filter

These settings allow you to apply filters to the MIDI data that will be transmitted and received by each timbres. For example even if two timbres are being played by the same MIDI channel, you can adjust the settings so that the damper pedal will apply to one but not the other.

On: Transmission and reception or reception (After Touch) of MIDI data is enabled.

If "Status" (p.20) is set to INT, effects that pertain to this setting is that are turned On will apply to the timbre's program when you use the microSTATION's controllers or when MIDI data is received. (The Effect Dynamic Modulation function is not affected by these settings.)

With the EXT or EX2 setting, the corresponding MIDI data will be transmitted on the channel of that timbre when you use the microSTATION's controllers. MIDI transmit/receive settings for the entire microSTATION are made in Global/Media mode "MIDI Filter" (p.63).

MIDI filtering for controllers whose function is user-assignable (the foot switch or foot pedal) will apply if that MIDI control change is assigned to the controller. If you assign the same control change as the damper or joystick, the damper or joystick setting will take priority. If the same control change is assigned to more than one controller, turning On just one of them will enable that control change.

Off: Transmission and reception of MIDI data is disabled.

Note: MIDI CC# = MIDI control change message numbers.

Prog Chg (Program Change) [Off, On]

Specifies whether or not MIDI program change messages will be transmitted and received.

Damper [Off, On]

Specifies whether or not MIDI CC#64 hold (damper pedal) messages will be transmitted and received.

JS X as AMS [Off, On]

Specifies whether or not MIDI pitch bend messages (the X axis of the joystick) will be received to control the AMS effect assigned to JS X. (This is not a filter for MIDI pitch bend message reception.)

JS+Y [Off, On]

Specifies whether MIDI CC#1 (the +Y axis of the joystick, or a realtime control knob assign setting) will be transmitted and received.

JS-Y [Off, On]

Specifies whether MIDI CC#2 (the -Y axis of the joystick, or a realtime control knob assign setting) will be transmitted and received.

Knob 1-A [Off, On]

Knob 2-A [Off, On]

Knob 3-A [Off, On]

Knob 4-A [Off, On]

These settings enable or disable transmission and reception of the MIDI messages assigned to knobs 1-4 when Realtime Control A mode is selected.

Knob 1-B [Off, On]

Knob 2-B [Off, On]

Knob 3-B [Off, On]

Knob 4-B [Off, On]

These settings enable or disable transmission and reception of the MIDI messages assigned to knobs 1-4 when Realtime Control B mode is selected.

Foot Switch**[Off, On]**

Specifies whether or not the effect of the assignable switch will be transmitted and received. The function is assigned in GLOBAL/MEDIA: Controllers–PEDAL/SW. This filter setting is valid when a MIDI control change is assigned.

Foot Pedal**[Off, On]**

Specifies whether or not the effect of the assignable pedal will be transmitted and received. The function is assigned in GLOBAL/MEDIA: Controllers–PEDAL/SW. This filter setting is valid when a MIDI control change is assigned.

Timbre 02....16

These are the MIDI Filter settings for timbres 2–16. They are the same as for timbre 1.

For more information, please see “Timbre 01” above.

Knob Assign

Here you can select the functions (mainly types of control change) that are assigned to knobs 1–4 when the REALTIME CONTROL SELECT button has selected B mode.

Knob 1–B **[Off...MIDI CC#119]****Knob 2–B** **[Off...MIDI CC#119]****Knob 3–B** **[Off...MIDI CC#119]****Knob 4–B** **[Off...MIDI CC#119]**

The functions you assign here are active when you use the REALTIME CONTROL SELECT button to select B mode, and operate knobs 1–4.

For more information, please see “Realtime Control Knob 1–4 Assign” on page 294.

Tempo

This is the tempo for the current Combination, which applies to tempo-synced LFOs and effects, arpeggiator, and tempo-synced effects.

⏸ (Tempo) **[040.00...300.00, EXT]**

Specify the tempo.

If Realtime Control C mode is selected, you can use knob 4 to adjust the tempo.

If “Clock” (MIDI Clock φ p.62) is set to Ext.MIDI or Ext.USB, EXT is shown. This is also shown if “Clock” is Auto and MIDI clock data is being received from an external device. If tempo is EXT, arpeggiator, LFO, and effects will synchronize to MIDI clock data from an external MIDI device.

For more information, please see “Clock (MIDI Clock Source)” on page 62.

ARP (Arpeggiator)

These parameters specify how the arpeggiator will function within the combination.

Two arpeggiators can run simultaneously.

You can take advantage of a wide range of possibilities; for example, separate arpeggio patterns can be applied to two key-split sounds, or two different arpeggio patterns can be switched using velocity.

You can also use the Realtime control C mode ARP GATE knob, ARP VELOCITY knob, ARP SWING knob, and TEMPO knob to control the arpeggiator in realtime.

To save the edits you make, use Write Combination.

ARP-A Setup

Run**[Off, On]**

This turns arpeggiator A on/off.

If this parameter is On, and you press the ARP ON/OFF button to turn it on and then play the keyboard, arpeggiator A will operate and will sound the timbre that’s assigned by the “Arp Assign” setting.

Pattern**[P0...P4, 000...639: name]****Octave****[1, 2, 3, 4]****Resolution****[♩, ♪, ♫, ♪, ♩, ♪]****Gate[%]****[000...100, Step]****Velocity****[001...127, Key, Step]****Swing[%]****[-100...+100]****Sort****[Off, On]****Latch****[Off, On]****Key Sync.****[Off, On]****Keyboard****[Off, On]****Top Key****[C–1...G9]****BottomKey****[C–1...G9]****Top Vel (Top Velocity)****[001...127]****Bottom Vel (Bottom Velocity)****[001...127]**

These parameters are the arpeggiator settings for the combination.

For more information, please see “ARP Setup” on page 9.

ARP-B Setup

Here you can adjust settings for the other arpeggiator (arpeggiator B). The parameters are the same as for arpeggiator A (ARP A).

For more information, please see “ARP Setup” on page 9.

Arpeggiator settings in Combination and Sequencer modes

In Combination and Sequencer modes, you can use two arpeggio patterns simultaneously, thanks to the microSTATION’s dual arpeggiator functionality. The settings in each of these modes are made in a similar way.

The following example shows how to adjust settings in Combination mode.

The dual arpeggiator functionality lets you do the following things.

- Assign an arpeggiator for each timbre. Choose from Off, (arpeggiator) A, or (arpeggiator) B.
- Independently specify whether A and B will operate.

- Select an arpeggio pattern and set parameters independently for A and B.
- Adjust Scan Zone page settings so that you can use keyboard range or playing velocity to switch between normal playing and arpeggiated playing, or to switch between arpeggiators A and B.
- Adjust settings for timbres that will be silent when the arpeggiator is Off, and will sound only when the arpeggiator is On.

Arpeggiator on/off

Each time you press the ARP ON/OFF button, the arpeggiator will be switched on or off/. The selected arpeggio pattern will begin when you play the keyboard. The on/off setting is saved when the combination is written into memory.

 If "ARP Assign" is Off or "Run" is off, the arpeggiator will not operate even if this key is on.

Arpeggiator settings

1. Use the COMBI EDIT: Timbres - Timbre 01–04 parameter "Program Select" to select a program for each timbre. For our example here, assign any desired program to timbres 1–4.
2. Set "Status" to INT for timbres 1–4, and set this "Off" for timbres 5–16. Set "MIDI Ch." to Gch for timbres 1–4.
3. Set "ARP Assign" to assign the arpeggiators to the timbres. Assign arpeggiator A to timbres 1 and 2, and assign arpeggiator B to timbre 3.
4. In COMBI EDIT: ARP - ARP-A Setup and ARP-B Setup, turn "Run" On.
When you turn the ARP ON/OFF button on, arpeggiators A and B will run.
When the ARP ON/OFF button is on, timbres 1 and 2 will be sounded by arpeggiator A, and timbre 3 will be sounded by arpeggiator B.
When the ARP ON/OFF button is off, playing the keyboard will sound timbres 1–4 as a layer.
5. In COMBI EDIT: ARP - ARP-A Setup and ARP-B Setup, edit the parameters of arpeggiators A and B. The available parameters for A and B are the same as in a program (p.9).
6. In ARP-A Setup and ARP-B Setup, the "Top Key" and "Bottom Key" parameters let you specify the region in which arpeggiators A and B will operate. Suppose you've made the following settings:
Arpeggiator A "Top Key" = G9, "Bottom Key" = C4
Arpeggiator B "Top Key" = B3, "Bottom Key" = C-1
With these settings, arpeggiator A will operate when you play keys C4 or higher, and arpeggiator B will operate when you play keys B3 or lower.
7. In the ARP A and ARP B pages, the "Top Vel" and "Bottom Vel" parameters let you specify the range of velocities for which arpeggiators A and B will operate. Suppose you've made the following settings:
Arpeggiator A "Top Vel" = 127, "Bottom Vel" = 064
Arpeggiator B "Top Vel" = 063, "Bottom Vel" = 000
With these settings, arpeggiator A will operate when you play strongly, and arpeggiator B will operate when you play softly.
In this way, you can switch between arpeggiators by specifying the range of keys or velocities, allowing you to create an even broader range of variation.
8. If you want to save the edited combination to internal memory, disable the memory protect setting in Global/Media mode, and then write the combination (p.60).

Combination Category: BASS & BASS SPLIT 018: DiscoSplit

Although this is a somewhat sophisticated editing technique, we will describe the settings of one of the preset combinations as an example.

Before you play, make sure that the global MIDI channel is set to 01.

Select combination Category: BASS & BASS SPLIT 018: DiscoSplit, make sure that the ARP ON/OFF button to turn it on, and play.

- Arpeggiator A is assigned to T (timbre) 5 and 6. When you play the keyboard, the drums arpeggio pattern will sound the T6 program.
- The A Bottom Key and Top Key (COMBI EDIT: ARP) are set so that arpeggiator A will operate only for notes B3 and lower.
- Arpeggiator A is also assigned to T5, but this is so that the T6 program will sound only when the arpeggiator is on.

Notice the timbre settings for T5 and T6

	Status	MIDI Ch.	Assign
T5	Off	Gch	A
T6	INT	02ch	A

- If the arpeggiator is off, playing the keyboard will sound the timbre(s) that are set to Gch or to the global MIDI channel (in this case, 01). Since the MIDI Channel of T6 is set to 02, it will not sound. T5 is set to Gch, but since "Status" is Off it will not sound.
- Notes from any MIDI channel that is assigned to a timbre will trigger the arpeggiator. In this case, these will be MIDI Channel 02 and Gch (global MIDI channel). When the arpeggiator is on, playing the keyboard will trigger arpeggiator A, which is assigned to T5 (Gch). T6 will be sounded by arpeggiator A. Since the Status of T5 is Off, it will not sound.
- Since the Status of T5 is Off, it will not sound, regardless of whether the arpeggiator is on or off. It is a dummy timbre that causes T6 to sound only when the arpeggiator is on.

Combination Category: BASS & BASS SPLIT 032: Echo Jam

Before you play, make sure that the global MIDI channel (p.60) is set to 01.

Select and play combination Category: BASS & BASS SPLIT 032: Echo Jam.

- Arpeggiator A is assigned to T4 and T6, and arpeggiator B is assigned to T2.
When you play a note B3 or lower, the T4 program will be sounded by the drums arpeggio pattern.
When you play a note B4 or higher, the T2 program will be sounded by the guitar riff arpeggio pattern.
- The A Bottom Key and Top Key (p.21) are set so that arpeggiators A will operate only for the note B3 and below.
- The B Bottom Key and Top Key (p.21) are set so that arpeggiators B will operate only for the note C4 and above.
- Arpeggiator B is assigned to T6 as well, but this setting is so that the T4 program will sound only when the arpeggiator is on.

IFX1, IFX2, IFX3, IFX4, IFX5

Here you can adjust settings for the insert effects. These consist mainly of the following.

- Select the effect type for each insert effect 1–5, and set the effect parameters.
- Turn each insert effect 1–5 on/off.
- Specify how the insert effects are connected, and adjust mixer settings for the signals that have passed through the insert effects.

For the insert effects, the direct (Dry) sound will always be stereo-input/output. The input/output structure of the effect (Wet) sound will depend on the type of effect (p.208).

The following parameters are the same as in Program mode.

However, insert effect dynamic modulation (Dmod) and the “Pan (CC#8),” “Send 1,” and “Send 2” parameters that follow the insert effect will be controlled by the MIDI channel specified by “Ch (Control Channel),” unlike in Program mode. The control changes used are the same as in Program mode (p.11).

IFX1

Here you can edit the effect parameters for insert effect 1.

IFX Select [S00...S63, D01...D10]

This selects the effect type for insert effect 1. (p.11)

IFX Parameters

Here you can set the parameters for the effect that’s selected by “IFX Select.” (p.11)

For details on the effect parameters, please refer to “Effect Guide” (p.217).

On/Off [Off, On]

Switches the insert effect on/off. (p.11)

Ctrl Ch (Control Channel) [01...16, G ch, All-R]

This parameter specifies the MIDI channel that will be used to control effect dynamic modulation (Dmod), pan following the insert effect (CC#8), Send 1, and Send 2.

The channel number of the timbre routed through this IFX will be followed by a “*” displayed at the right of Ch01–16. If two or timbres with different MIDI channel settings are routed through the same IFX, this parameter specifies which of these channels will be used to control the effect.

G ch: The global MIDI Channel (p.60) will be used to control the effect. Normally you will set this to G ch.

All-R (All Routed): The channel of any timbre routed through this effect can be used to control the effect. (Channels of each routed timbre will be indicated by “*.”)

 If the “Bus” parameter (p.19) is set to DKit for a timbre for which a drum program is selected, the MIDI channel of that timbre will be enabled if any of the insert effects IFX1–IFX5 are set to All-R, regardless of the bus select setting of each key of the drum kit or the “DKit Patch” setting.

Chain [Off, On]

ChainTo [IFX2...IFX5]

Pan (CC#8) [L000...C064...R127]

Bus (Bus Select) [Off, L/R]

FXCtrl Bus (FX Control Bus) [Off, 1, 2]

Send1 [000...127]

Send2 [000...127]

See “IFX1, IFX2, IFX3, IFX4, IFX5” on page 11.

IFX2, IFX3, IFX4

Here you can edit the effect parameters for insert effects 2–4.

IFX Select [S00...S61, D01...D09]

This selects the effect type for insert effects 2–4. (p.12)

IFX Parameters

Here you can set the parameters for the effect that’s selected by “IFX Select.” For details on the effect parameters, please refer to “Effect Guide” (p.217).

On/Off [Off, On]

Switches the insert effect on/off. (p.11)

Ctrl Ch (Control Channel) [Ch01...16, G ch, All-R]

This parameter specifies the MIDI channel that will be used to control effect dynamic modulation (Dmod), pan following the insert effect (CC#8), Send 1, and Send 2.

For more information, please see “Ctrl Ch (Control Channel)” on page 25.

ChainTo [IFX3...IFX5]

Chain [Off, On]

Pan (CC#8) [L000...C064...R127]

Bus (Bus Select) [Off, L/R]

FXCtrl Bus (FX Control Bus) [Off, 1, 2]

Send1 [000...127]

Send2 [000...127]

See “IFX1, IFX2, IFX3, IFX4, IFX5” on page 11.

IFX5

Here you can edit the effect parameters for insert effect 5.

IFX Select [000...61]

This selects the effect type for insert effect. IFX5 cannot use double-size effects.

IFX Parameters

Here you can set the parameters for the effect that’s selected by “IFX Select.” For details on the effect parameters, please refer to “Effect Guide” (p.217).

On/Off [Off, On]

This turns the insert effect on and off. (p.11)

Ch (Control Channel) [Ch01...16, G ch, All-R]

This parameter specifies the MIDI channel that will be used to control effect dynamic modulation (Dmod), pan following the insert effect (CC#8), Send 1, and Send 2.

For more information, please see “Ctrl Ch (Control Channel)” on page 25.

ChainTo [IFX3...IFX5]

Chain [Off, On]

Pan (CC#8) [L000...C064...R127]

Bus (Bus Select) [Off, L/R]

FXCtrl Bus (FX Control Bus) [Off, 1, 2]

Send1 [000...127]

Send2 [000...127]

See “IFX5” on page 12.

MFX1, MFX2

Here you can adjust settings for the master effects. These consist mainly of the following.

- Select the effect type for each master effect, and set the effect parameters.
- Turn each master effect on/off.
- Specify how the master effects are connected, and specify the level at which the signal from the effects are returned to the L/R bus.

The following parameters are the same as in Program mode. (☞“MFX1, MFX2” on page 13)

MFX1

MFX1 Select [S00...S87, D00...D13]

This selects the effect type for master effect 1. (☞“MFX Select” on page 13)

MFX Parameters

Here you can set the parameters for the effect that’s selected by “MFX Select.”

For details on the effect parameters, please refer to “Effect Guide” (☞p.217)

On/Off [Off, On]

Switches the master effect 1 on/off. When off, the output will be muted. (☞“On/Off” on page 13)

Ctrl Ch (Control Channel) [01...16, G ch, All-R]

Specifies the MIDI channel that will control dynamic modulation (Dmod) for the master effect. (☞“Ctrl Ch (Control Channel)” on page 25)

01...16: The specified MIDI channel will be used for control.

G ch: The global MIDI Channel (☞p.60) will be used for control. Normally you will use the G ch setting.

Return 1 [000...127]

This specifies the return level from the master effect 1 to the L/R bus (after which it passes through TFX, and is sent from OUTPUT L/MONO and R).

Chain [Off, On]

On: Master effects 1 and 2 will be connected in series, in the order of master effect 1 → master effect 2.

ChainLevel [000...127]

When “Chain” is On, this specifies the level of the signal sent from master effect 1 to master effect 2.

 If you’re using a double-size effect, the “Chain” settings will be unavailable.

MFX2

MFX2 Select [000...120]

MFX Parameters

On/Off [Off, On]

Ctrl Ch (Control Channel) [01...16, G ch, All-R]

Return 2 [000...127]

See “MFX1” on page 26..

TFX (Total Effect)

Here you can adjust settings for the total effect, which is located at the final stage of the L/R bus. These consist mainly of the following.

- Select the effect type for the total effect, and set the effect parameters.
- Turn the total effect on/off.

The following parameters are the same as in Program mode. (☞“TFX” on page 13)

TFX

TFX Select [S00...S61]

This selects the effect type for total effect.

 TFX cannot use double-size effects.

TFX Parameters

Here you can set the parameters for the effect that’s selected by “TFX Select.”

For details on the effect parameters, please refer to “Effect Guide” (☞p.217).

On/Off [Off, On]

This turns total effect on/off. If this is off, the input will be passed directly through. (☞“On/Off” on page 13)

Ctrl Ch (Control Channel) [01...16, G ch, All-R]

Specifies the MIDI channel that will control dynamic modulation (Dmod) for the total effect. (☞“Ctrl Ch (Control Channel)” on page 25)

01...16: The specified MIDI channel will be used for control.

G ch: The global MIDI Channel (☞p.60) will be used for control. Normally you will use the G ch setting.

Master Vol

Master Vol (Master Volume) [000...127]

This specifies the final level of the audio output that has passed through total effect, and output from OUTPUT L/ MONO and R.

Command

These commands allow you to do things such as copying or initializing arpeggiator or effect settings. Specify the copy-source and copy-destination, get the "OK?" prompt, and then press the ► button to begin.

For copy-related commands, please note the following points when using "From" and "Src" to specify the copy-source.

- If you specify Program or Combi in "From," the "Src" field will show a bank number such as "A000." This indication matches the bank number shown in the upper right of the display when you turn NUMLOCK on in PROG PLAY or COMBI PLAY and press the function 14 (ENTER) button.
- If you specify Song in "From," the "Src" field will show a song number. In this case, you can choose only song numbers that are loaded into the microSTATION or that you created on the microSTATION.

Copy ARP (Copy Arpeggio)

This command copies arpeggio settings.

From [Program, Combi, Song]
Src (Source) [A000: name..., 000: name...]
Src's [A, B, A&B]

See "Copy Arpeggio" on page 14.

To [A, B]
 When copying from a program, or when copying A or B (not both) from a combination or song, specify either A or B as the copy-destination. This is not shown if "Src's" is set to A&B.

Copy IFX

This command copies effect settings from a specified program, combination, or song (☞ "Copy IFX" on page 14). However, the "Ch (Control Channel)" setting is not copied.

Swap IFX

This command swaps (exchanges) the settings of two insert effects (☞ "Swap IFX" on page 14).

However, the "Ch (Control Channel)" setting is not swapped.

Copy MFX/TFX

This command copies effect settings from a specified program, combination, or song. (☞ "Copy MFX/TFX" on page 14)

However, the "Ch (Control Channel)" setting is not copied.

Initialize All

This command initializes the settings of the combination that's currently selected.

Copy Prog (Copy from Program)

This command copies the settings of the specified program to the combination that's currently selected.

- The "Status" setting (☞ p.20) is automatically set to INT.
- "MIDI Ch." (☞ p.20) will not change if "With Arp?" is Yes, or will automatically be set to Gch if "With Arp?" is No.
- The PROG EDIT: Knob Assign settings of the copy-source program will be copied.

From [A000...D127: name]
 Select the copy-source program.

With FX? [Yes, No]
 Specify whether the insert effect 1–5, master effect 1 and 2, and total effect settings will be copied.

About the "Bus" setting

- Regardless of the "With FX?" setting, if the copy-source program's "UseDKitSet" parameter is On, "Bus" will be set to DKit. In addition, the "DKit IFX Patch" setting will be reset to the default.
- If "With FX?" is set to Yes, the copy-source program's "Bus Select" setting will be copied. If the "Bus" setting of timbres other than the copy-destination timbre is IFX1–IFX5, it will automatically be set to L/R.
- If "With FX?" is set to No, the "Bus" settings of the copy-source program and the copy-destination timbre will automatically be set to L/R if they were both IFX1–IFX5.

With Arp? [Yes, No]
 Specify whether the copy-source program's arpeggiator settings will be copied. The copy-source program's arpeggiator settings will be copied to the arpeggiator specified by "To Arp," and assigned to the copy-destination timbre.

To Timbre [01...16]
 Select the copy-destination timbre. Parameters for that timbre will be initialized. The copy-source program will be assigned to "Program Select" (☞ p.17).

To Arp [A, B]
 Specify the copy-destination arpeggiator (A or B).

Write Combi

This saves the edited combination to the microSTATION's memory. You can use this to do the following.

- Save the edited content.
- Rename a combination.
- Specify the combination's category.
- Copy a combination to a different bank or combination number.

 Be sure to save important combinations. An edited combination cannot be recovered if you turn off the power or select a different combination before you've saved it.

 Before you can write, you must turn off memory protect in Global mode.

Name [space, !...~]

Specify the combination name. Use the ◀▶ buttons to select a character, and use the ▲▼ buttons to change the character. You can enter up to twenty-four characters.

Cat (Category) [KEYBOARD...USER]

Select the category for the combination you're saving.

To [A000...C127: name]

Specify the save-destination for the combination. The microSTATION allows you to save 384 programs.

The save-destination is indicated by bank number. This bank number matches the bank number shown in the upper right of the display when you turn NUMLOCK on in COMBI PLAY and press the function 14 (ENTER) button. You can specify A000–C127; the GM2 bank is not available for saving.

Note: Combinations on the microSTATION are internally managed by bank and number. The saved combination will be written to a bank number A000–C127.

OK?

Press the ► button to save the data.

Note: You can also save the combination by pressing the WRITE button. When you press the WRITE button, a confirmation screen of "OK" will appear. When you do this, the combination will be saved by overwriting the combination that's currently selected.

External Setup

You can use the microSTATION's external control functionality to control an external MIDI device; press the REAL-TIME CONTROLS EXTERNAL button and use knobs 1–4 to transmit MIDI control change messages on the specified MIDI channel.

Setup Select [000...127: name]

This selects the setup that will be used for external control. You can choose from 128 setups.

Preload setup data is loaded when the microSTATION is shipped from the factory. For example, these include setups that let you control the Korg Legacy Collection of software synthesizers, and setups that lets you control DAW software.

For more information, please see "microSTATION External Setups (PDF)"

You can use Global/Media: MIDI - External Setup to assign the function of each knob in an external setup (p.64).

1	[MIDI ch/MIDI CC#: Knob value]
2	[MIDI ch/MIDI CC#: Knob value]
3	[MIDI ch/MIDI CC#: Knob value]
4	[MIDI ch/MIDI CC#: Knob value]

These indicate the assignments for knobs 1–4 in the selected external setup. From the left, these are the MIDI channel / MIDI control change / current knob value. The knob value can be edited.

Sequencer mode

An overview of Sequencer mode

Sequencer Mode lets you record and play back MIDI data on sixteen MIDI tracks and one master track (containing tempo data, etc.), using the internal sound generator or external sound modules.

The dual arpeggiator, GRID SEQ (grid sequence) function, the sophisticated effects, controllers, and the numerous other functions of the microSTATION can be used together to give you a wide range of possibilities for music production or live performance.

 When you turn off the power, the Sequencer mode settings, the songs you've recorded will disappear. If you need to keep this data, you must save it to an SD card before powering-off.

If you wish to save the programs, track parameters, and effects, settings etc. selected for a song as a template song, use the song command "Save Template."

When you initially power up the microSTATION, it will not contain any song data, so if you wish to playback a song on the sequencer, you must first load data from media. (☞ "Load" on page 68)

MIDI sequencer

- The sequencer can record a maximum of 210,000 MIDI events, up to 128 songs, and as many as 999 measures per song.
- Timing resolution is a maximum of $\frac{1}{480}$.
- There are sixteen tracks for MIDI performance data, and a master track that controls the time signature and tempo.
- The arpeggiator can be used during playback or recording.
- For each song, you can use five stereo insert effects, two stereo master effects, and one stereo total effect.
- Sixteen different template songs are built-in, and contain program and effect settings suitable for various musical styles. Up to sixteen original templates that you create can be saved as user template songs.
- A track play loop function lets you loop specified measures independently for each track.

MIDI recording features

- Various methods of recording are supported, in which your performance on the keyboard and controllers (including MIDI control events) is recorded as you play.
- You can use the front panel function 01–16 buttons to easily switch tracks, select a recording track, or change a track's play/mute status.
- The Grid Sequence function lets you use the front panel function 01–16 buttons and 01–16 LEDs to step-record phrases such as drum patterns in a grid-like manner.
- MIDI System Exclusive (SysEx) messages can be recorded and played back. SysEx messages received from an external MIDI device or parameter changes produced by editing track parameters or effect parameters can be recorded in real-time on any desired track.

Parameter-related features

- When the "Status" of a track is set to INT or BTH, an external sequencer can be used to play the microSTATION as a multi-timbral tone generator. When the Status of a track is set to BTH, EXT, or EX2, the sequencer of microSTATION can play external tone generators. (☞ "Status" on page 38)
- Tone parameters (Filter/Amp, Filter/Amp EG) let you make temporary adjustments to the sound of the program used by a track, while leaving the original program unchanged. While creating a song, you can use this capability to make changes in realtime by (for example) softening the tone of the bass sound or sharpening the attack of the strings without having to return to Program mode to edit the program itself. (☞ "Tone parameters" on page 39)
- microSTATION's AMS (Alternate Modulation) capability lets you use control changes for realtime control of the parameters of the programs used in a program. Its MIDI Sync abilities let you synchronize the LFO speed to changes in the tempo.
- Dmod (Dynamic Modulation) functionality lets you control effect parameters in realtime. You can also use MIDI Sync to synchronize the LFO speed or delay time to changes in the tempo.
- The MIDI clock master can be set to Internal, Ext.USB, Ext.MIDI, or Auto, allowing synchronized performance with an external MIDI device. (☞ "Clock (MIDI Clock Source)" on page 62)

Editing and operation features

- The Auto Song Setup function lets you instantly set up program or combination settings of Program mode or Combination mode as a song, so that you can start recording simply by pressing the START/STOP button. Since performances using the Arpeggiator in Program or Combination mode are seamlessly integrated with song production, any inspiration or ideas for phrases and songs that occur to you while playing can be immediately be turned into a song. (☞ "Tips: Auto Song Setup" on page 30)
- Program and Combination settings can be copied to a song. (☞ "Copy Combi (Copy from Combination)" on page 50, ☞ "Copy Prog (Copy from Program)" on page 51)
- A song you created can be converted into SMF (Standard MIDI File) data. SMF songs can also be loaded. (☞ "Save To SMF (Save Song as Standard MIDI File)" on page 69)
- Song data you create can be saved in a dedicated format. (☞ "Save SEQ" on page 69)
- You can rewind or fast-forward MIDI Tracks while listening to the sound.
- The LOCATE button lets you move quickly to a desired location.
- When editing MIDI tracks, you can use the front panel 01–16 buttons to switch tracks quickly.

Setup parameters & Musical data

Each song consists of MIDI tracks 1–16, a master track, various song parameters such as the song name, settings for the arpeggiator, effect settings.

Up to 128 such songs can be created in the microSTATION. MIDI tracks 1–16 each consist of "track parameters" that specify the starting state of the track, and "playback data." The master track consists of tempo and time signature data.

MIDI tracks 1–16

Setup parameters

Program, Play/Rec/Mute, Pan*, Volume*, Play Loop, Loop Start Measure, Loop End Measure, Play Intro, Bus, FXCtrl Bus, Send1, Send2, Dkit Patch, Status, MIDI Channel, Bank Select (When Status=EX2)**, OSC Mode**, OSC Select, Portamento*, Transpose**, Detune**, Bend Range**, Filter/Amp, Filter/Amp EG, Use Program's Scale***, Delay (Mode, Time, Base Note, Times)***, MIDI Filter, Keyboard Zone, Velocity Zone, Track Name

Musical data

Note On/Off
 Program Change (including Bank Select)
 Pitch Bend
 After Touch (Poly After)
 Control Change
 Exclusive Message

Master track

Setup parameters/Musical data

Time signature*, Tempo*

* When you change the setting during realtime-recording, this will be recorded as musical data (Program change and Control change messages). This allows the starting settings to be modified during the playback.

** Musical data (MIDI RPN data) can be used to change the starting settings during playback.

Other parameters: You can adjust parameters during realtime recording and record these changes as MIDI System Exclusive messages. This means that the settings at the start of playback can change as the song progresses.

***: These parameters are supported only by microSTATION Editor.

- For details on Control Change messages and RPN, please see [“Control change”](#) on page 304, and [“Using RPN \(Registered Parameter Numbers\)”](#) on page 307.
- For details on MIDI System Exclusive messages, please see [“System Exclusive events supported in Sequencer mode”](#) on page 55.

The Global mode “SEQ Mode” setting

In Sequencer mode, you will normally use the internal sequencer as the master that controls the internal sound generator or external MIDI sound modules. However, you can also use the microSTATION as a multi-timbral sound module that can simultaneously play multiple tracks of performance data from an external MIDI sequencer. (Normally, you'll use Combination mode if you want to use the microSTATION as a master keyboard.)

You can switch the microSTATION's setting as appropriate for these two purposes. This setting is made in Global/Media: MIDI- SEQ Mode “Trk.”

“for Master” is the appropriate setting if you want to use the microSTATION's internal sequencer to control an external sound module, or use the microSTATION in Sequencer mode as a master keyboard. In this case when you switch songs on the microSTATION, tracks whose Status is set to EXT or BTH can transmit MIDI messages such as program changes to set up your external MIDI sound module.

“for ExtSeq” is the appropriate setting if you want to use the microSTATION as a multi-timbral sound module for your external sequencer. When you switch songs on the microSTATION, MIDI messages such as program changes will not be transmitted (by tracks whose Status is EXT or BTH). This ensures that echo-back from your external MIDI sequencer will not cause microSTATION tracks of the corresponding

MIDI channel to switch their program, pan, or volume settings.

Tips: Auto Song Setup

This function automatically copies the settings of a program or combination to a song, and puts the microSTATION in a condition ready to record.

Procedure (example for Combination mode)

1. Enter Combination mode.
2. Select a desired combination, and use COMBI EDIT to edit the arpeggiator etc. as desired.
 Note: If you want to save the edited state, execute “Write Combi.”
3. Press the REC button.
 The display will indicate “Auto Song Setup OK?”
4. If you want to begin the Auto Song Setup function, press the **▶** button; if you decide not to then, press the **◀** button.

You'll automatically switch to Sequencer mode, and the settings of the combination will be copied to the song. The copy-destination song will be the first song that's currently unused.

Combination settings applied automatically

The result will be the same as when you use the Song command “Copy Combi” with the following settings ([p.50](#)).

- “With FX?” = Yes
- “Multi Rec?” = Yes

Program settings applied automatically

The result will be the same as when you use the Song command “Copy Prog” with the following settings ([p.51](#)).

- “With FX?” = Yes
- “With ARP?” = Yes
- “To Track” = 01
- “To ARP” = A

5. The microSTATION will automatically be in record-ready mode, and the metronome will sound according to the Metronome settings ([p.34](#)).
6. Press the START/STOP button to start realtime-recording. When you're finished recording, press the START/STOP button once again.

The Compare function

When you perform realtime recording or track editing, this function allows you to make before-and-after comparisons. If you continue editing when the COMPARE LED is lit, the LED will go dark. This now becomes the musical data that will be selected when the COMPARE LED is dark.

Operations for which Compare is available

In general, track and pattern event data can not be returned to its original state. Comparing song parameters is possible only during song editing (when executing a song command).

- Recording to a MIDI track
- Track Edit
 “Erase Track,” “Copy Track,” “Erase Measure,” “Delete Measure,” “Insert Measure,” “Repeat Measure,” “Copy Measure,” “Create Control,” “Quantize”
- Song commands
 “Delete,” “Copy Song”

 The program will not be affected by the Compare, and will not return to its prior state.

Operations for which Compare is not available

- Editing song parameters
- Song commands other than those listed under “Operations for which Compare is available,” above.

The microSTATION’s song parameter page structure

The microSTATION’s Sequencer mode is organized as the tree structure shown on the following page. (☞p.32)

For details on how to move between pages, select parameters, and edit values, refer to the “microSTATION Operation Guide.”

SEQ

Here you can select a song and view the location.

Song Select [000...127: Song Name]

Select the song that you want to record or play back.

Creating a new song

Use the Song command “Create New” to create a new song. Use “Length” to specify the number of measures in the song that will be created.

If you want to change the length of a song after creating it, use the Track Edit “Set Song Length.” When creating a new song, you can specify the length to be somewhat longer than necessary, and after you have finished recording and editing, use “Set Song Length” to specify the correct length.

MIDI A Song Select message is transmitted when you switch songs on the microSTATION. You can switch songs on the microSTATION remotely, by sending a Song Select message from an external MIDI device.

If “Trk” (Global/Media: MIDI–SEQ MIDI Out) is set to “for Master,” and the song is switched, tracks whose track status (☞p.38) is EXT, EX2, or BOTH will transmit Bank Select, Program Change, Volume, Panpot, Portamento, Send 1/2, Post IFX Pan, and Post IFX Send 1/2 messages on the MIDI channel of that track. These messages will not be transmitted if Track MIDI Out is set to “for ExtSeq.”

Location [001:01....999:16]

The location (current position) in the song is shown as the Measure (001–999) and Beat (01–16) in the upper line of the display.

You cannot specify the location here; to specify the location, use the Set Location pages in PLAY or REC.

Selecting a track

You can select the MIDI track to play or record from the keyboard. With the front panel TIMBRE/TRACK LED lit, press one of the function 01–16 buttons to select a track.

You can also use this method to select a MIDI track to edit when using a command such as “Copy Track.”

When you realtime-record onto a single track, the performance data will be recorded onto the track you select here.

You’ll also use the function 01–16 buttons to select the desired tracks when you realtime-record onto multiple tracks.

To rename a track, use “Rename” (☞p.41).

MIDI When you play the keyboard of microSTATION and operate its controllers, the internal tone generator will sound according to the settings (program level etc.) of the tracks that are selected here (if “Status” is INT or BTH), and other tracks whose MIDI channels match

will also sound at the same time (if “Status” is INT or BTH). Message will also be transmitted on the MIDI channels of these tracks (whose “Status” is EXT, EX2 or BTH).

PLAY

In the PLAY page, the location is shown in the upper line of the display. Use “Set (Set Location)” to specify the location. The lower line shows playback-related parameters, and allows you to edit them.

LOOP-P (Loop Play)

This page appears when you press the front panel LOOP button to turn Loop on, allowing you to set the following parameters.

Loop M: Start – End [001...999]

This specifies the first and last measure that will be looped. When Loop is on, all tracks will play repeatedly according to this setting.

Tempo, Tempo Mode**♪(Tempo) [040.00...300.00, EXT]**

This specifies the tempo of the song. This tempo applies to song playback, arpeggiator.

040.00...300.00: When the “Tempo Mode” is Manu (Manual), this tempo will be used for recording and playback. When “Tempo Mode” is Rec, this tempo will be recorded on the master track.

EXT: This will appear when “Clock” (MIDI Clock ☞p.62) is set to either Ext.MIDI, Ext.USB or Auto. The tempo of the internal sequencer will synchronize with MIDI Clock messages received from an external sequencer or other MIDI device.

If “Clock” is set to Internal, the above tempo setting (040.00–300.00) is used. If you’ve selected Auto, operation will automatically switch from Internal to External if MIDI Clock data is received from an external MIDI device. This indication will appear.

Note: If Realtime Control C mode is selected, you can also adjust the tempo by turning knob 4 (TEMPO).

Tempo Mode [Auto, Manu]

Auto: The tempo of the master track will be used. You can specify the master track tempo either by setting the Track Edit “Edit Tempo” parameter, or by recording with “Tempo Mode” set to Rec. If you choose the Auto setting, you won’t be able to change the “♪(Tempo)” setting during song playback or recording.

Manu (Manual): The “♪(Tempo)” setting will be used.

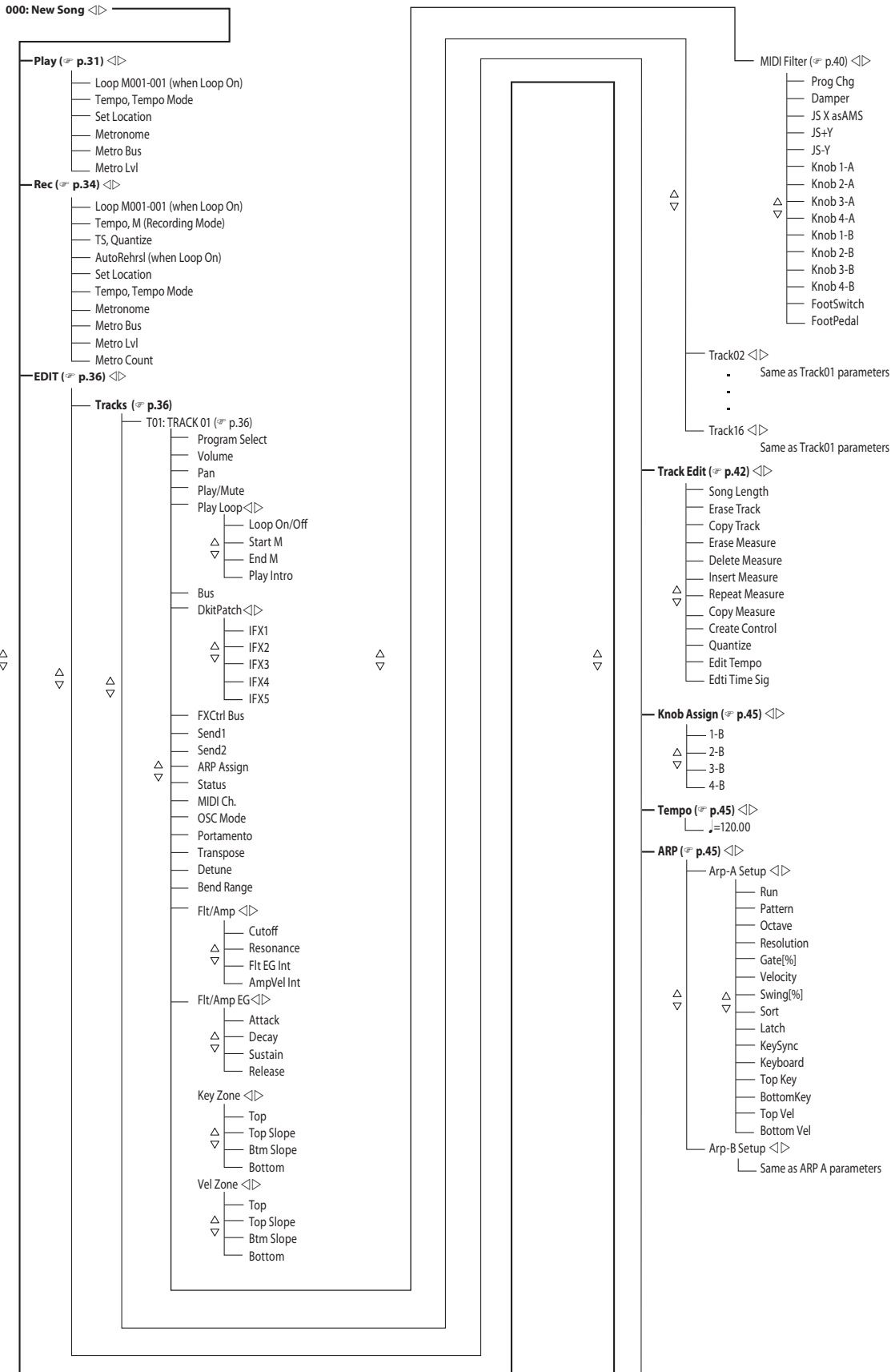

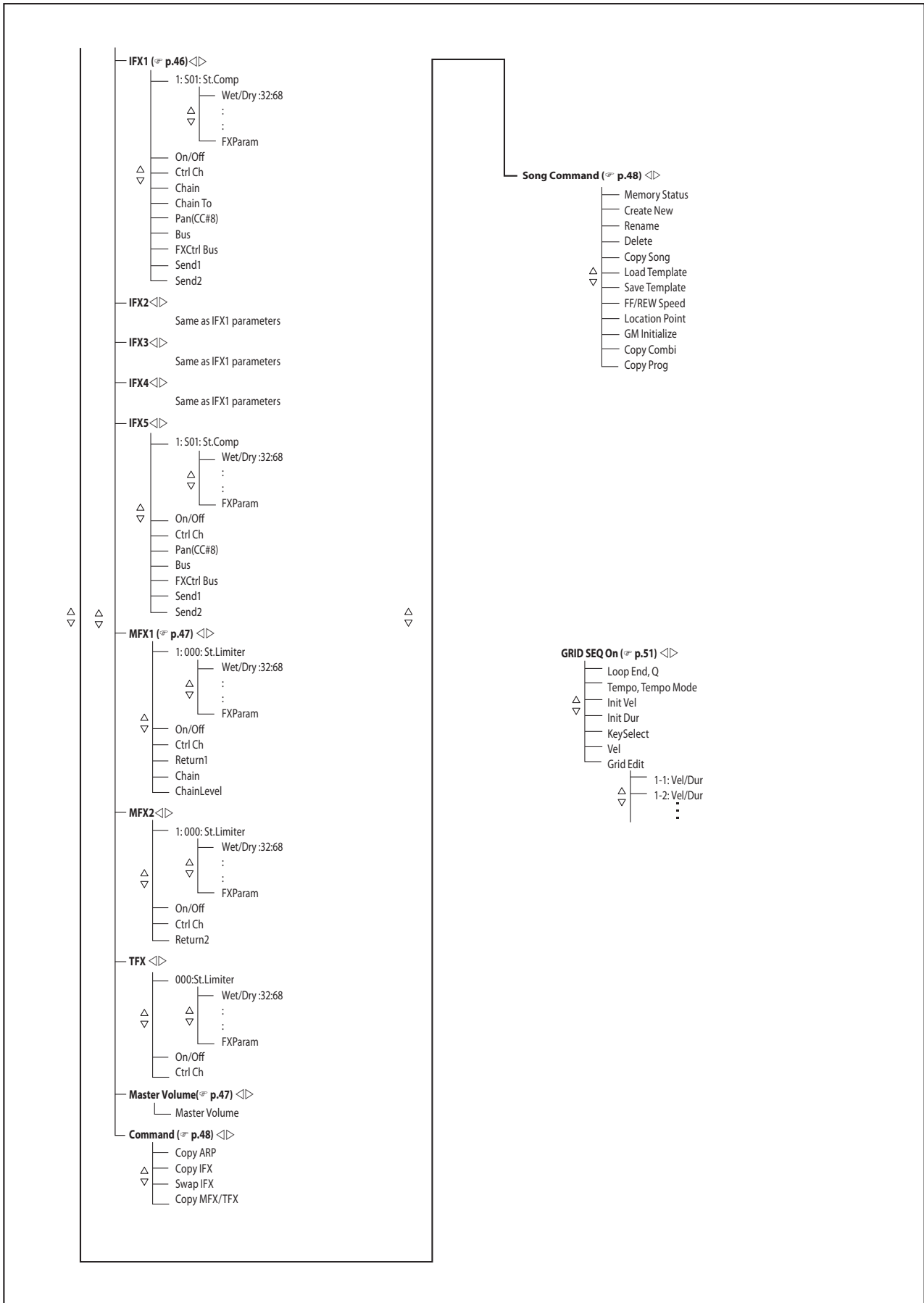



Set Location

Set (Set Location) [001:01....999:16]

This specifies the location. The position will change to the measure you specify here. From the left, these values indicate the measure (001–999) and the beat (01–16).

 If the MIDI source clock (☞ “Clock (MIDI Clock Source)” on page 62) is Internal, changing the location will transmit a song position pointer message. If the MIDI source clock is Ext. and MIDI “Rcv ExtRTC” (☞ p.62) is on, the location will change when a song position pointer message is received from the specified source.

With the Auto setting, the microSTATION will automatically switch to the same operation as Ext.MIDI when it receives external MIDI clock data from a device connected to the MIDI IN connector. Otherwise, operation will be the same as Internal.

 The adjustable range for the beat and clock will depend on the time signature that is specified at that point.

Metronome

Metronome [Rec, R&P, Off]

Rec: The metronome will sound only during recording.

R&P: The metronome will sound during recording and playback.

Off: The metronome will not sound during playback or recording. However, the pre-count metronome will sound before recording begins.

Metronome Bus Select

Metro Bus [L/R, L, R]

Selects the output destination of the metronome sound.

L/R: Output from OUTPUT L/Mono and R.

L: Output from OUTPUT L/Mono.

R: Output from OUTPUT R.

Metronome Level

Metro Lvl [000...127]

Sets the volume of the metronome.

REC

Here you can specify how recording will occur.

When you press the REC button to enter the record-ready condition, the display will show a REC group page. The most recently displayed page of the REC group will be the page that is shown.

In the REC pages, the upper line of the display shows the location. Use “Set (Set Location)” to specify the location. In the lower line you can view and edit recording-related parameters.

Loop-Recording (Loop Recording)

If you press the front panel LOOP button to turn loop recording on, Loop All Tracks Recording mode will be selected; recording will occur repeatedly over the specified region of measures of the tracks, allowing you to continue adding data. This mode is ideal for creating drum patterns.

 You can't turn LOOP on when using multi-recording. Nor can you multi-record when LOOP is on.

Loop M: Start – End [001...999]

This specifies the region in which recording will repeat when loop recording is on.

Tempo, Recording Mode

♪ (Tempo) [040.00...300.00, EXT]

This specifies the tempo of the song. (☞ “♪ (Tempo)” on page 31)

M (Recording Mode) [OVW, OVD, MPI, API]

Selects the method of realtime recording.

 If you press the front panel LOOP button to turn loop recording on, this parameter will be ignored, and will not be displayed. The display will indicate “Q (Quantize Resolution),” which can be edited.

OVW (Overwrite): With this method, the newly recorded data overwrites musical data previously recorded on that track. If you use this method to record on a track on which data has already been recorded, all previous data will be replaced from the measure at which you began recording through all subsequent measures. When recording for the first time, you will normally select this method.

OVD (Overdub): With this method, the newly recorded musical data is added to the existing data.

Select this method when you wish to add data to a previously-recorded track. It is best to select this mode if you will be recording additional control data, recording a drum pattern, or recording the tempo in the master track.

With this mode, data can be added without erasing the existing performance data.

MPI (Manual Punch In): With this method, the musical data previously on the track is overwritten by the newly recorded data.

Select this method when you wish to use the REC button or a foot switch to re-record selected portions of a previously-recorded track.

While the song is playing, you can press the REC button or a connected pedal switch at the desired location to start or stop recording.

API (Auto Punch In): With this method, the musical data previously on the track is overwritten by the newly recorded data.

Select this method when you wish to automatically re-record selected portions of a previously-recorded track.

Recording will occur only over the specified area, rewriting it with the newly recorded data.

First you must specify the area that will be re-recorded.

Then recording will automatically start and end within the specified area.

Time Signature, Quantize

TS (Time Signature)

[/**, 1/4...16/4, 1/8...16/8, 1/16...16/16]**

This is the time signature at the current location of the song. The time signature can be changed at each measure.

****/****: This will be displayed when you press the REC button. Specify this when you wish to use the time signature that is already recorded for that measure, and wish to record without changing the time signature.

1/4...16/4, 1/8...16/8, 1/16...16/16: This is the time signature at the current location in the song.

With the front panel TIMBRE/TRACK LED lit, use the 01–16 buttons to select the track that you want to record; then press the REC button and specify the time signature here.

When you press the START/STOP button to begin recording, the time signature you specify will be recorded on the Master Track and on previously recorded tracks.

Be aware that if you press the START/STOP button during the pre-count to stop recording, the time signature will not be recorded.

Normally, you will specify the time signature when you record the first track, and select ****/**** when recording subsequent tracks.

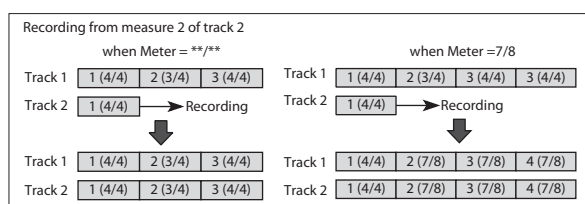

Changing the time signature in the middle of a song

Changing the time signature before data is recorded:

If you know the location at which you wish to change time signatures, use the Track Edit “Insert Measure” to specify and insert the time signature wherever desired, and then record your musical data.

Changing the time signature after data has been recorded:

If you want to change the time signature mid-way through a song that already contains performance data, use the Track Edit “Edit Time Sig” (p.45) to specify a measure and change the time signature.

If the number of beats in a measure increases when you modify the time signature, rests will be inserted in the portion that was added. Conversely if the number of beats decreases, that portion will not be played. However if you return to the original time signature, the data that had been hidden will once again be played. (The data itself will not be erased.)

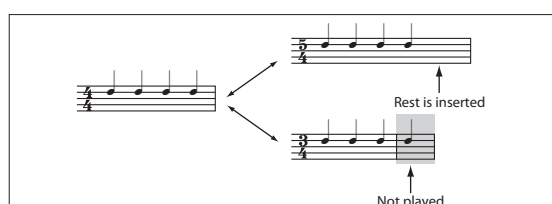

Q (Quantize Resolution) [Hi, $\frac{1}{3}$, $\frac{1}{4}$, $\frac{1}{8}$, $\frac{1}{16}$, $\frac{1}{32}$, $\frac{1}{64}$]

With realtime-recording, the timing of the MIDI data you play can be corrected.

Hi (High Resolution): Timing will not be corrected. Data will be recorded at the maximum resolution ($\frac{1}{192}$).

$\frac{1}{3}$... $\frac{1}{64}$: Data will be corrected to the nearest interval of the specified timing as it is recorded. For example if you select $\frac{1}{3}$, data will be corrected to the nearest 32nd-note triplet interval. If you select $\frac{1}{4}$, data will be corrected to the nearest quarter note interval.

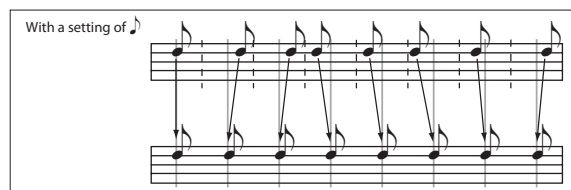

Because all the MIDI data being recorded will be corrected to the specified timing resolution, coarse settings of this parameter will cause continuous controllers such as pitch bend to be recorded in “stair-step” fashion.

In such cases, use a setting of Hi to record, and then use the Track Edit “Quantize” to correct only the desired type of data (notes etc.). To avoid a stiff feel, avoid recording at a low resolution to begin with.

Auto Rehearsal

The Auto Rehearsal function lets you select and try out different sounds for the track while you play the keyboard without having to exit loop recording, or to work out a phrase before you actually record it. This is available and displayed only when loop is turned on.

AutoRehrls

[Off, On]

This turns auto rehearsal on/off. It specifies how function buttons 01–16 will operate when you use them to switch the recording track during loop recording.

Off: Auto rehearsal off. When you switch the recording track, recording mode will continue without change.

On: Auto rehearsal on. When you switch the recording track, the function button 01–16 LED corresponding to the selected track will blink, and you’ll be in rehearsal mode.

In rehearsal mode, recording will not occur when you play the keyboard. After you switch tracks, you’ll normally select a program or try out the phrase you will be recorded. If this is the case, turn auto rehearsal on.

When you’re ready to resume recording, press the function button 01–16 that corresponds to the blinking track.

Rehearsal mode will alternate on/off each time you press the button.

Set Location

Set (Set Location)

[001:01...999:16]

Use this to specify the location; you’ll move to the specified measure. From the left, the numbers indicate the measure (001–999) and beat (01–16).

Tempo, Tempo Mode

♩ (Tempo)

[040.00...300.00, EXT]

This specifies the tempo of the song. (♩ “Tempo”) on page 31)

Tempo Mode [Auto, Manu, Rec]

Auto: The tempo will follow the tempo of the Master Track. You can record master track tempo data either by using the Track Edit command “Edit Tempo,” or by setting “Tempo Mode” to Rec during recording.

When Auto is selected, it will not be possible to modify the “♩(Tempo)” setting while a song is playing or recording (or during standby).

Manu (Manual): The ♩(Tempo) setting will be used.

Rec: Tempo changes will be recorded on the Master Track.

Changing the tempo

With the front panel TIMBRE/TRACK LED lit, use function buttons 01–16 to select a track. Press REC to enter record-standby mode. Set “Tempo Mode” to Rec, start recording, and change the “♩(Tempo)” value. You can also select Real-time Controls C mode and use knob 4 (TEMPO) to change the tempo.

⚠ “Rec” cannot be selected if the LOOP button is on.

If you change the “♩(Tempo)” value during recording, the tempo change will be recorded, causing the tempo to change during the song.

You can also specify tempo changes by using the track edit command “Edit Tempo.”

Note: If you want to record only tempo changes, set “M (Recording Mode)” (p.34) to OVD (OverDub). The tempo will be recorded on the master track without affecting the performance data of the track that’s currently selected by function buttons 01–16.

Auto Punch In Measure

This page is displayed and can be edited if “M (Recording Mode)” is set to API (auto punch in recording).

APIn Start M: Start–End [M001...M999]

This specifies the measures at which recording will start and end when “M (Recording Mode)” is set to API (auto punch in recording).

Metronome**Metronome** [Rec, R&P, Off]

Rec: The metronome will sound only during recording.

R&P: The metronome will sound during recording and playback.

Off: The metronome will not sound during playback or recording. However, the pre-count metronome will sound before recording begins.

Metronome Bus Select**Metro Bus** [L/R, L, R]

Selects the output destination of the metronome sound.

L/R: Output from OUTPUT L/Mono and R.

L: Output from OUTPUT L/Mono.

R: Output from OUTPUT R.

Metronome Level**Metro Lvl** [000...127]

Sets the volume of the metronome.

Metronome Precount**Metro Count** [0...2]

Specifies the pre-count that will occur before recording begins.

With a setting of 0, recording will begin the instant you press the START/STOP button (after first pressing the REC button).

EDIT**Tracks**

Here, you can adjust the settings for each MIDI track.

Track 01 (Track Number)**Program Select** [001: Name...]

Selects the program that will be used by each MIDI track.

The program you select here will be used when the song is played or recorded from the beginning. If the program is changed while recording, the program change will be recorded as MIDI data, and the program will change during playback. You can also change the program manually during playback. However, the program will change at any point where program change data is already recorded.

 If the Status (p.38) is either INT or BTH, programs can be selected by receiving MIDI program change messages. Also, when the song is changed or when the song returns to the beginning, tracks whose Status is EXT, EX2 or BTH will transmit the bank and program numbers via MIDI. Tracks whose Status is EX2 will show Bank as “–” and will transmit the bank number that was selected in the Bank Select (p.166) parameter. (See Global/Media: MIDI–SEQ Mode “Trk (Track MIDI Out)” on page 62)

Switching the track’s program

With the front panel TIMBRE/TRACK LED lit, press a function button 01–16; the “Program Select” page will appear. This page lets you easily perform basic operations such as switching tracks or selecting programs.

⚠ If you’ve accessed the edit page for track parameters or track selection in SEQ EDIT: Tracks, simply switching tracks will not access the “Program Select” page.

To switch a track’s program, use any of the following methods from the “Program Select” page:

- Use the CATEGORY SELECT buttons to select a category, and use the ▲▼ buttons to select a program.
- Use the CATEGORY SELECT buttons to select a category, press the NUM LOCK button (lit) to turn num lock on, then use function buttons 01–10 to enter a program number, and finally press the ENTER (14) button.
- Transmit a MIDI program change from a connected external MIDI device. (“Status” must be set to INT or BTH.) The MIDI program change number for the program that’s currently selected will be shown in the display if you press the NUM LOCK button (lit) to turn num lock on, and then press the ENTER (14) button.
- You can also use the above methods to switch programs while a song is playing. If you switch programs while

recording, the program change data will be recorded, and the program will switch at that point in the song during playback.

Pan [RND, L001...C064...R127]

Here, you can set the pan of each MIDI track.

L001...C064...R127: A setting of L001 is far left and R127 is far right. A setting of C064 will reproduce the oscillator pan setting of the Program mode.

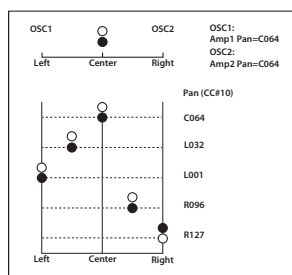
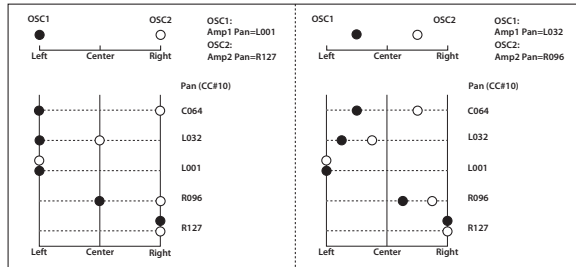

If a mono insert effect is in use, the settings you make here will be ignored. In this case, the Pan: #8 parameter in IFX1–IFX5 page will adjust the panning of the sound after the Insert Effect. For more information, please see “Mixer” on page 210.

RND: The pan position will change randomly at each note-on.

MIDI If “Status” (p.38) is INT or BTH, CC#10 Pan can be received to control the panning. When receiving CC#10, a value of 0 or 1 is far left, 64 is center, and 127 is far right. When you change the song or return to the beginning of the song, tracks whose Status is EXT, EX2 or BTH will transmit the pan you specify here as a MIDI message (except for RND). (See Global/Media: MIDI-SEQ Mode “Trk” on page 62)

Volume [000...127]

Here, you can set the volume of each MIDI track.

MIDI When “Status” (p.38) is INT or BTH, CC#7 Volume can be received to control the volume. The volume of a track is determined by multiplying the MIDI Volume (CC#7) and Expression (CC#11) values. When you change the song or return to the beginning of the song, tracks whose Status is EXT, EX2 or BTH will transmit the volume you specify here as a MIDI Volume message. (See Global/Media: MIDI-SEQ Mode “Trk” on page 62)

Play/Mute [Play, Mute]

This allows you to mute the MIDI tracks.

Press the front panel PLAY/MUTE button to turn it on (LED lit), and then use function buttons 01–16 to switch the play/mute status of each track.

Play: The track will play.

Mute: The track will be muted.

DKit Patch

This lets you patch the bus select setting for each key of a drum kit, temporarily changing the connection destinations to the insert effects.

These settings are available if the program used by the timbre is a drum program and “Bus” (p.37) is set to DKit.

MIDI This setting is available if a drum kit’s bus select setting is IFX1–IFX5.

- IFX1** [L/R, IFX1...IFX5, Off]
- IFX2** [L/R, IFX1...IFX5, Off]
- IFX3** [L/R, IFX1...IFX5, Off]
- IFX4** [L/R, IFX1...IFX5, Off]
- IFX5** [L/R, IFX1...IFX5, Off]

Choose each insert effect’s patch destination as IFX1–IFX5, L/R, or Off.

If you want to return to the settings of the drum kit, set IFX1: IFX1, IFX2: IFX2, IFX3: IFX3, IFX4: IFX4, and IFX5: IFX5.

Bus [DKit, L/R, IFX1...IFX5, Off]

This specifies the output bus for the track’s program oscillator.

For more information, please see “Bus (Bus Select)” on page 19.

- Send1** [000...127]
- Send2** [000...127]

For each track, these parameters set the send level to master effects 1 and 2. These settings are valid when “Bus” is set to L/R or Off. When IFX1–IFX5 are selected, the send levels to master effects 1 and 2 are set by the Send1 and Send2 parameters of the IFX1–IFX5 page, and are applied after the sound has passed through IFX1–IFX5.

The Send 1 and 2 setting you specify here are used during playback or recording from the beginning of the song. If you modify these settings during recording, your changes will be recorded as performance data; the send amounts will change accordingly during playback. You can also modify these settings during playback. However if Send 1 and 2 data has been recorded, the settings will change according to the recorded data.

MIDI If “Status” (p.38) is either INT or BTH, CC#93 and CC#91 can control send 1 and 2 respectively and change their settings. When you switch songs or return to the beginning of a song, tracks whose Status is EXT, EX2 or BTH will transmit these settings via MIDI. This data will be transmitted on the MIDI channel of each track as set by “MIDI Ch.” (p.39). The actual send level is determined by multiplying the value of these parameters with the send level settings of the program used by the track (Send1 and Send2 p.11). (“Trk (Track MIDI Out)” on page 62)

FXCtrl Bus (FX Control Bus) [Off, 1, 2]

Sends the output of the track to an FX Control bus (two-channel mono FX Ctrl 1 or 2).

For more information, please see “FXCtrl Bus (FX Control Bus)” on page 19.

ARP Assign [Off, A, B]

This individually assigns arpeggiator A or arpeggiator B to each tracks. When the ARP ON/OFF button is turned on, the arpeggiator specified for each track will run, subject to the Arpeggiator Run A, B settings and the settings made here.

Off: Neither arpeggiator will operate.

A: Enables Arpeggiator A. Use the ARP-A page to select the arpeggio pattern and set the parameters.

B: Enables Arpeggiator B. Use the ARP-B page to select the arpeggio pattern and set the parameters.

For tracks that you wish to record, select either arpeggiator A or B. If you specify an arpeggiator for two or more tracks, the arpeggiator will play each of the tracks you specify.

You can set A and B to two different MIDI channels, and control one from the keyboard and the other from an external MIDI device connected to MIDI IN. You can also use multi-track recording (Multi REC) to simultaneously record the note data that is generated from the two arpeggiators.

Example 1)

On tracks 1 and 2, set MIDI Channel (“MIDI Ch.” p.39) to 01 and “Status” (p.38) to INT.

Assign arpeggiator A to track 1 and arpeggiator B to track 2. Turn on the Arpeggiator A, B “Run” setting.

- Use the front panel function buttons 01–16 to select track 1. With the ARP ON/OFF button off, play the keyboard and tracks 1 and 2 will sound simultaneously. When you turn on the ARP ON/OFF button and play the keyboard, arpeggiator A will operate for track 1 and arpeggiator B will operate for track 2.

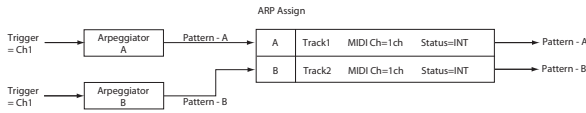

Example 2)

For tracks 1, 2 and 3, set the MIDI Channel (“MIDI Ch.” p.39) to 01, 02, and 03 respectively, and set “Status” (p.38) to INT.

Assign arpeggiator A to tracks 1 and 2, and arpeggiator B to track 3.

Turn on the Arpeggiator A, B “Run” setting.

- In Track Select, choose Track01. Playing the keyboard when the ARP ON/OFF button is off will play the sound assigned to track 1. Playing the keyboard when the ARP ON/OFF button is on will cause arpeggiator A to operate for tracks 1 and 2, and produce sound for both tracks.
- In Track Select, choose Track02. Playing the keyboard when the ARP ON/OFF button is off will play the sound assigned to track 2. Playing the keyboard when the ARP ON/OFF button is on will cause arpeggiator A to operate for tracks 1 and 2, and produce sound for both tracks.
- In Track Select, choose Track03. Playing the keyboard when the ARP ON/OFF button is off will play the sound assigned to track 3. Playing the keyboard when the ARP ON/OFF button is on will cause arpeggiator B to operate for track 3, and play the sound assigned to track 3.
- Alternatively, you can use the 01–16 buttons to select track 1, start arpeggiator A to play tracks 1 and 2, and use an external MIDI device connected to the microSTATION’s MIDI IN to transmit note data on MIDI channel 3 to trigger arpeggiator B and play track 3.

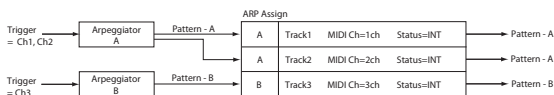

The arpeggiator cannot be triggered by the notes played by the sequencer.

MIDI If the track “Status” (p.38) is set to INT or BTH, tracks 1–16 where arpeggiator A or B are assigned will be sounded by the note data generated by the arpeggiator, regardless of the MIDI Channel (“MIDI Ch.” p.39) setting of that track. If the track “Status” is set to BTH, EXT, or EX2, the track will transmit MIDI note data on the MIDI Channel of that track.

In this case, arpeggiator A or B will be triggered by the MIDI Channel of any track 1–16 where the corresponding arpeggiator is assigned.

MIDI If the Local Control On (“Local Ctrl” p.61) is turned OFF, the arpeggiator will not be triggered by note data from the keyboard. It will be triggered by note data received at MIDI IN. If you wish to record just the trigger notes on an external sequencer and run the microSTATION’s arpeggiator in this way, turn Local Control OFF.

If you want the note data generated by the arpeggiator to be recorded on the external sequencer, turn Local Control ON, and turn off the echo back function of the external sequencer. (p.311)

Status [Off, INT, BTH, EXT, EX2]

This sets whether the Track controls the internal sounds, external MIDI devices, or both.

Off: Use this to disable the Track. With this setting, the Track’s Program will not sound, and MIDI data will not be transmitted.

INT: The track will sound when you play back the performance data recorded on the MIDI track. If you select a MIDI track that is set to INT, the microSTATION’s sound generator will produce sound when played. MIDI data will not be transmitted to an external device.

BTH: Both INT and EXT are operative. When the musical data recorded in the MIDI track is played back, or when you select a MIDI track that is set to BTH and play the controllers of the microSTATION, the internal tone generator of the microSTATION will sound, and MIDI data will also be transmitted to an external device.

EXT: When the musical data recorded in the MIDI track is played back, or when you select a MIDI track that is set to EXT and play the controllers of the microSTATION, MIDI data will be transmitted to an external device, but the internal tone generator of the microSTATION will not sound.

When you select another song or return to the beginning of the song, the program change, volume, panpot, portamento, sends 1 and 2, post IFX pan, and post IFX sends 1 and 2 of each MIDI track set to EXT will be transmitted via MIDI. (p.62)

EX2: This enables you to specify a particular MIDI Bank Select message for the Track, instead of automatically using the Bank of the selected microSTATION Program. Use the parameters below, labeled Bank Select MSB (When Status =EX2), to set the Bank Select message as desired. In other respects this is the same as EXT, described above.

MIDI MIDI data is transmitted and received on the MIDI channel that is specified separately for each MIDI track by the MIDI Channel.

Status	Recorded data Keyboard and controller operations		Received data	
	internal tone generator	MIDI OUT	internal tone generator	MIDI OUT
INT	Yes	No	Yes	–
EXT, EX2	No	Yes	No	–
BTH	Yes	Yes	Yes	–

MIDI Ch. (MIDI Channel) [01...16]

Specifies the MIDI channel that the MIDI track will use to transmit and receive musical data. The MIDI channel you specify here will be the receive channel when "Status" is INT, the transmit channel when it is EXT or EX2, and the receive/transmit channel when it is BTH. Tracks set to INT which have the same MIDI channel will sound and be controlled identically when they receive MIDI data or data from the sequencer tracks.

OSC Mode [PRG, Poly, Mono, Legt]

This lets you override the Program's stored Voice Assign Mode (☞ "Voice Mode (Voice Assign Mode)" on page 3) settings, if desired.

PRG: The Program's stored Voice Assign Mode settings will be used.

Poly: The track will play polyphonically, regardless of the Program's settings.

Mono: The track will play monophonically, regardless of the Program's settings.

Legt (Legato): The track program will sound monophonically, and will play legato according to the Program's setting.

With the MN or LGT settings, the Program's setting will determine the priority of the note that sounds when you play two or more notes.

Portamento [PRG, Off, 001...127]

Make portamento settings for each MIDI track.

The portamento setting you make here will be used when the song is played or recorded from the beginning. If you change the setting while recording, it will be recorded as part of the musical data. (However if you set this to PRG, it will not be recorded.) You can change this setting during playback. However if you play back any Portamento On/Off data or Portamento Time data that was previously recorded, the settings will change accordingly.

MIDI When the track whose "Status" is INT or BTH, MIDI control change CC#05 (Portamento Time) and CC#65 (Portamento Switch) can be received to control this and change the setting. (If the setting is PRG, CC#05 Portamento Time will not be received.)

When you switch songs or return to the beginning of the song, tracks whose Status is BTH, EXT, or EX2 will transmit this setting via MIDI. If this is Off, CC#65 with a value of 0 will be transmitted. If this is 001-127, a CC#65 of 127 and CC#05 of 1-127 will be transmitted. If this is set to PRG, nothing will be transmitted.

This data is transmitted and received on the MIDI channel specified for each track by "MIDI Ch." (☞ "Trk (Track MIDI Out)" on page 62)

Transpose [-60...+00...+60]

Adjusts the pitch of each MIDI track in semitone steps. 12 units equal one octave.

Detune [-1200...+0000... +1200]

Adjusts the pitch of each MIDI track in one-cent units.

+0000: Normal pitch.

MIDI "Transpose" and "Detune" do not affect the notes transmitted via MIDI Out. "Transpose" and "Detune" can be controlled via MIDI RPN messages received on the Track's MIDI channel. The way that this works depends on whether or not the Track uses a Drum Program.

- Programs that use one or two oscillators can receive MIDI RPN coarse tune messages to control the "Transpose" setting and fine tune messages to control the "Detune" setting.

- Drum programs which use a drum kit can receive MIDI RPN coarse tune and fine tune messages to control the "Detune" setting. The range of control is a total of +/-1 octave when coarse tune and fine tune are added together.

Bend Range [PRG, -24...+0...+24]

Specifies the amount of pitch change that will occur when the pitch bender is operated, in semitone units.

PRG: The pitch range specified by the program will be used.

-24...+24: This setting will be used regardless of the setting in the program.

MIDI As long as this is set to something other than PRG, you can control the Bend Range using MIDI RPN Pitch Bend Change messages.

Tone parameters

The Program mode tone parameters in the Filter/Amp through the Filter/Amp EG groups can be edited individually for each track.

These parameters are Relative parameters. They apply an upward or downward adjustment to the value of the program parameter.

These changes are saved in the song, and do not affect the original program.

MIDI Some parameters in these groups are interrelated with control by specific MIDI CC messages. The values of these parameters are followed by an indication such as "CC#74".

For more information, please see "Interaction between parameters and MIDI CCs" on page 79.

Filter/Amp:**Cutoff (Filter Cutoff)** [-99...+99 (Rel, CC#74)]

This scales the cutoff frequency of all of the filters at once. It affects both Filters A and B.

Resonance (Filter Resonance)

[-99...+99 (Rel, CC#71)]

This scales the resonance of all of the filters at once. It affects both Filters A and B.

Filt EG Int (Filter EG Intensity)

[-99...+99 (Rel, CC#79)]

This scales the effect of the Filter EG on the cutoff frequency. It affects Filters A and B simultaneously. (☞ "Filt EG Int (Filter EG Intensity)" on page 21)

AmpVel Int (Amp Velocity Intensity)

[-99...+99 (Rel)]

This scales the effect of velocity on the Amp level.

(☞ "AmpVel Int (Amp Velocity Intensity)" on page 21)

Filter/Amp EG:**Attack (Filter/Amp EG Attack Time)**

[-99...+99 (Rel, CC#73)]

This scales the attack times of the Filter and Amp EGs, along with other related parameters. (☞ "Attack (Filter/Amp EG Attack Time)" on page 21)

Decay (Filter/Amp EG Decay Time)

[-99...+99 (Rel, CC#75)]

This scales the decay and slope times of the Filter and Amp EGs.

Sustain (Filter/Amp EG Sustain Level)
[–99...+99 (Rel, CC#70)]

This scales the sustain levels of the Filter and Amp EGs.

Release (Filter/Amp EG Release Time)
[–99...+99 (Rel, CC#72)]

This scales the release times of the Filter and Amp EGs.

Key Zone:

Here, you can specify the key zones in which MIDI tracks 1–16 will sound.

The top/bottom key settings specify the zone in which MIDI tracks 1–16 will sound, and the top/bottom slope settings specify the key range over which the volume will change starting from the top/bottom key.

For more information, please see “Key Zone” on page 21.

MIDI These settings do not affect MIDI transmission/reception. All note data that is received will be recorded into the internal sequencer, and all note data from the internal sequencer or from the keyboard will be transmitted.

Top **[C–1...G9]**
 Specifies the top key (upper limit) of the notes that will sound for each MIDI track.

Top Slope **[00, 01, 02, 03, 04, 06, 08, 10, 12, 18, 24, 30, 36, 48, 60, 72]**

Specifies the range of keys (12 is one octave) over which the volume will be reached starting from the top key.

0: The volume will be at the original level from the top key.

12: The volume will increase gradually as you play downward, and will reach the original volume one octave below the top key.

72: The volume will increase gradually as you play downward, and will reach the original volume six octaves below the top key.

Btm Slope **[00, 01, 02, 03, 04, 06, 08, 10, 12, 18, 24, 30, 36, 48, 60, 72]**

Specifies the range of keys (12 is one octave) over which the volume will be reached starting from the bottom key.

0: The volume will be at the original level from the bottom key.

12: The volume will increase gradually as you play upward, and will reach the original volume one octave above the bottom key.

72: The volume will increase gradually as you play upward, and will reach the original volume six octaves above the bottom key.

Bottom **[C–1...G9]**

Specifies the bottom key (lower limit) of the notes that will sound for each MIDI track.

How volume will change according to keyboard location

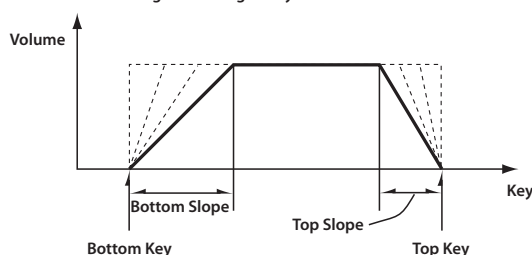

Top Key and Bottom Key settings can also be input by holding down the KEY button and playing a note on the keyboard.

⚠ It is not possible to set the bottom key above the top key of the same track. Nor is it pos

Vel Zone (Velocity Zone):

Here, you can set the Top/Bottom Velocity parameters to specify the range of velocities that will be sounded by MIDI tracks 1–16, and Top/Bottom Slope specify the range over which the volume will be adjusted.

For more information, please see “Vel Zone (Velocity Zone)” on page 22.

MIDI These settings do not affect MIDI transmission/reception. All note data that is received will be recorded into the internal sequencer, and all note data from the internal sequencer or from the keyboard will be transmitted.

⚠ It is not possible to set the bottom velocity greater than the top velocity for the same track. Nor can the top slope and the bottom slope overlap.

Top **[1...127]**
 Specifies the maximum velocity value that will sound each track.

Top Slope **[000...120]**
 Specifies the number of velocity steps over which the original volume will be reached, starting from the Top Velocity.

000: The volume will be at the original value from the top velocity.

120: The volume will decrease as the velocity approaches the top velocity.

Btm Slope **[000...120]**

Specifies the number of velocity steps over which the original volume will be reached, starting from the Bottom Velocity.

000: The volume will be at the original value from the bottom velocity.

120: The volume will decrease as the velocity approaches the bottom velocity.

Bottom **[001...127]**

Specifies the minimum velocity that will be sounded by each MIDI track 1–16.

How volume will change according to keyboard location

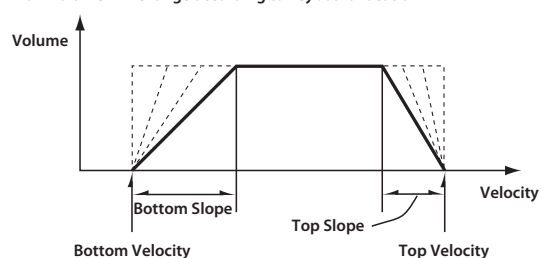

Top Velocity and Bottom Velocity settings can also be input by holding down the KEY button and playing a note on the keyboard.

MIDI Filter:

Prog Chg (Program Change) **[Off, On]**

Specifies whether or not MIDI program change messages will be received.

Damper **[Off, On]**

Specifies whether or not MIDI CC#64 hold (damper pedal) messages will be received.

JS X asAMS [Off, On]

Specifies whether or not MIDI pitch bend messages (the X axis of the joystick) will be received to control the AMS effect assigned to JS X. (This is not a filter for MIDI pitch bend message reception.) For more information, please see “AMS (Alternate Modulation Source) List” on page 287.

JS+Y [Off, On]

Specifies whether or not MIDI CC#1 (the +Y axis of the joystick, or a realtime control knob assign setting) will be received.

JS-Y [Off, On]

Specifies whether or not MIDI CC#2 (the -Y axis of the joystick, or a realtime control knob assign setting) will be received.

Knob 1-A [Off, On]

Knob 2-A [Off, On]

Knob 3-A [Off, On]

Knob 4-A [Off, On]

These settings enable or disable reception of the MIDI messages assigned to knobs 1-4 when the Realtime Control Amode is selected.

Knob 1-B [Off, On]

Knob 2-B [Off, On]

Knob 3-B [Off, On]

Knob 4-B [Off, On]

These settings enable or disable reception of the MIDI messages assigned to knobs 1-4 when the Realtime Control B mode is selected.

Foot Switch [Off, On]

Specifies whether or not the effect of the Assignable switch will be received. The function is assigned in Global/Media: Controllers- PEDAL/SW page. This filter setting is valid when a MIDI control change is assigned.

Foot Pedal [Off, On]

Specifies whether or not the effect of the Assignable pedal will be received. The function is assigned in Global/Media: Controllers- PEDAL/SW page. This filter setting is valid when a MIDI control change is assigned.

Play Loop

Loop [Off, On]

Specifies looping for a MIDI track.

On: That track will loop between “Start M” and “End M.”

Start M (Loop Start Measure) [001...999]

Specifies the first measure of the loop.

End M (Loop End Measure) [001...999]

Specifies the last measure of the loop.

Play Intro [Off, On]

On: After the measures before the specified “Start M” are played once, the region of “Start M” – “End M” will be played repeatedly.

For example, you can use this on a drum track to make it play a fill-in and then begin looping.

Off: Playback will begin from the “Start M,” and will begin looping immediately.

 This setting is valid if “Loop” is On and “Start M” is set to other than 001.

Examples: Set “Start M”: 003 and “End M”: 004

If “Play Intro” is turned On

The track will loop as follows:

M001 - M002 - M003 - M004 - M003 - M004 - M003 - M004 ...

If “Play Intro” is turned Off

The track will loop as follows:

M003 - M004 - M003 - M004 - M003 - M004 - M003 - M004 ...

You can take advantage of “Play Loop” to make the realtime recording process more efficient.

Rename

Rename [!...~]

Here you can edit the name of the track. Use the ◀▶ buttons to select a character, and use the ▲▼ buttons to specify the desired character. You can enter up to twenty-four characters.

Track02...Track16 (Track Number)

Here, you can set the parameters for tracks 2-16. The settings are the same as for track 1.

For more information, please see “Track 01 (Track Number)” on page 36.

Track Edit

These commands let you edit MIDI tracks 1–16 and the master track. For MIDI tracks, you can copy, move, insert, or delete specified measures or tracks.

For the master track, you can edit the tempo and time signature.

Use function buttons 01–16 to select a track and access the edit page. Set the parameters as desired, access the “OK?” display and press the ► button to begin the operation.

Song Length

This command changes the length (number of measures) of the song. Executing this will change the length of the master track, changing the number of measures that will play.

Length [001...999]

Specify the length of the song.

⚠ Any data in measures beyond the specified “Length” will be deleted.

Erase Track

This command erases data from the specified track. It is not possible to erase just the master track alone.

Track [01...16]

Specify the track whose data will be erased.

All Tracks [No, Yes]

No: The performance data will be erased only from the track you specified in “Track.”

Yes: The performance data will be erased from all tracks.

Copy Track

This command copies performance data from the copy-source track to the specified destination track. Be aware that the track data in the copy-destination will be erased when you begin the copy track operation.

From Track [01...16]

Specify the copy-source track. The track that’s currently selected will be the default.

To Track [01...16]

Specify the copy-destination track.

Erase Measure

This command erases various types of performance data from the specified measures. You can also use the erase measure command to erase only a specific type of data. Unlike the delete measure command, the erase measure command will not cause the performance data of subsequent measures to move forward.

Track [01...16]

Specify the track from which you want to erase data.

Trk’sM*-M***** [001...999]

Specify the measures from which you want to erase data.

Kind [All, Note, Ctrl Chg, AfterT, PitchBend, Prog Chg, SysEX]

Select the type of data that you want to erase.

All: All types of data in the track will be erased.

Note: Note data will be erased.

Ctrl Chg: Control change data will be erased.

AfterT: Both channel pressure and polyphonic key pressure will be erased.

PitchBend: Pitch bend data will be erased.

Prog Chg: Program change data will be erased.

SysEX: System exclusive data will be erased.

All Tracks [Yes, No]

Specify whether data will be erased from all tracks or from only the specified track.

No: The data specified by “Kind” will be erased only from the selected track.

Yes: The data specified by “Kind” will be erased from all tracks.

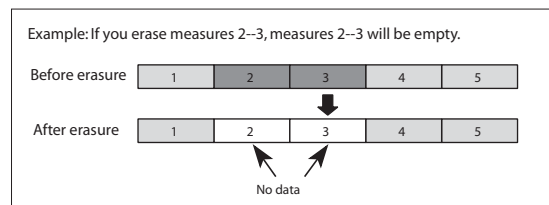

⚠ If control data extends across the boundary between the erased region of measures and an unerased region, only the data within the specified region will be erased.

⚠ Be aware that if there is note data that sustains across several measures, erasing an intervening measure will cause that note data to be erased from the subsequent measure as well.

Delete Measure

This command deletes the specified measures. When you use the delete measure command, the performance data that follows the deleted measures will move forward to fill the gap.

Track [01...16]

Specify the track from which you want to delete measures.

Trk’sM*-M***** [001...999]

Specify the measures to be deleted.

All Tracks [Yes, No]

Specify whether the measures will be deleted from all tracks or from only the specified track.

No: The measures will be deleted only from the specified track.

Yes: The measures will be deleted from all tracks.

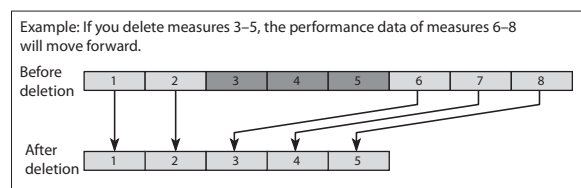

⚠ If you use this command with “All Tracks” set to No, the master track will not be deleted. The time signature and tempo data will remain as it was, meaning that the time signature and tempo will change for the measures that were moved forward by the deletion.

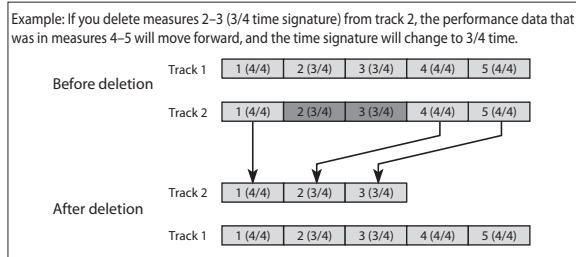

If you select this command with “All Tracks” set to Yes, the performance data of all tracks including the master track will be deleted from the specified measures, and the time signature and tempo will also move forward by the corresponding number of measures.

If any data extends across the boundary between deleted and undeleted measures, the data will be deleted only from the specified region.

If you delete measures from within a region that note data extends across, the note data will be deleted from the following measures as well.

Insert Measure

This command inserts the specified number of measures into the specified track. When you select the insert measure command, the performance data following the insert location will be moved backward.

If you insert measures at a location within a note that is connected by a tie, a note-off will be created immediately before the insert location, and the rest of that note will be erased.

Track [01...16]
Specify the track in which measures will be inserted.

at Measure [001...999]
Specify the location at which measures will be inserted.

Length [001...999]
Specify the number of measures that will be inserted.

Time Sig [**/**, 1/4...16/16]
Specify the time signature of the measures that will be inserted.

If you want the time signature of the inserted measures to match the existing time signature, choose **/**. With any setting other than **/**, the time signature of the inserted measures will be changed, so that all tracks will be the specified time signature.

All Tracks [Yes, No]
Specify whether measures will be inserted into all tracks.

No: Measures will be inserted only into the track you specify. The performance data following the insert location will be moved backward by the number of measures inserted; be aware that the time signature and tempo will not move.

Yes: Measures will be inserted into all tracks including the master track. Performance data following the inserted measures will play in the same way as before you executed this command.

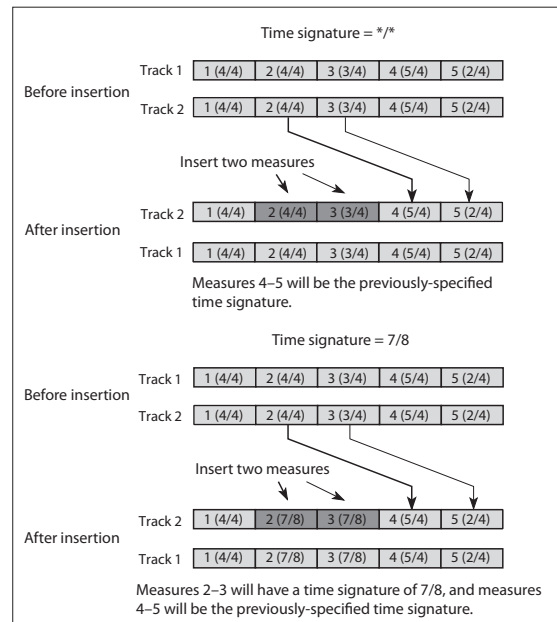

Repeat Measure

This command copies performance data from the specified region of measures from a track and inserts it the specified number of times. When you use the repeat measure command, the data will be inserted starting at the measure that follows “To End of Measure,” and the performance data that followed this insert location will be moved backward. If you’ve turned on “Play Loop” (p.41) for a song, and would like to expand the repetitions into performance data, this command provides a convenient way to do so.

Track [01...16]
Specify the track where the Repeat Measure command will be used.

Trk’sM*-M***** [001...999]
Specify the region of measures that will be repeated.

Times [002...999]
Specify the number of times that the region will repeat.

For example if you set “From Measure” to 001, “To End of Measure” to 004, and “Times” to 002, then the performance data of measures 1-4 will be inserted at measures 5-8, with the result that measures 1-4 will be played twice.

All Tracks [Yes, No]
No: The performance data will be inserted into the track that’s currently selected. Performance data following the insert location will be moved backward by the number of measures inserted, but the time signature and tempo will not move.

Yes: The performance data will be inserted into all tracks including the master track. Performance data following the inserted measures will play as it did before.

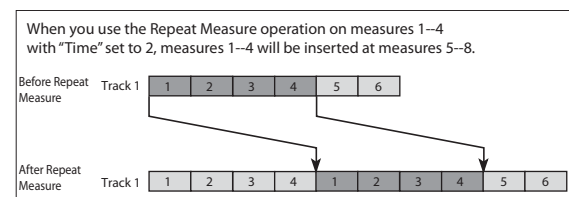

Copy Measure

This command copies performance data from the copy-source to the specified measure.

When you use the Copy Measure command, the track data at the copy-destination will be overwritten.

From Track [01...16]

Specify the copy-source track.

Trk'sM*-M***** [001...999]

Specify the region of copy-source measures.

All Tracks [Yes, No]

No: The performance data will be copied from the track that's currently selected. Be aware that although the performance data at the copy-destination will be overwritten, the time signature and tempo will not be overwritten.

Yes: The performance data of all tracks including the master track will be copied.

To [S000...S127]

Specify the copy-destination song.

To Track [01...16]

Specify the copy-destination track. This is available of "All Tracks" is No.

To Measure [001...999]

Specify the starting measure where the data will be copied.

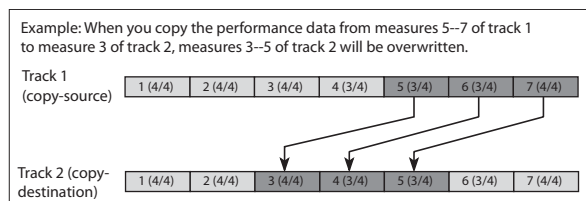

Create Control (Create Control Data)

This command creates control change, aftertouch, or pitch bend data in the specified region of a MIDI track.

Track [01...16]

Specify the track where you'll use the Create Control Data command.

From [001:01...999:16]

To [001:01...999:16]

Specify the region in which the control data will be created.

Kind [CC#000...119, AfterT, PitchBend]

Specify the type of performance data (event) that will be created.

CC#000...119: Control change data will be created.

AfterT: Aftertouch data will be created.

PitchBend: Pitch bend data will be created.

Start Val (Start Value) [000...127]

End Val (End Value) [000...127]

Specify the values of the control data at the start and end of the region.

By default, "Start Val" will be set to the current value at the start position. If you want to create control data that changes smoothly from the start position, leave "Start Val" at this setting, and change only the "End Val."

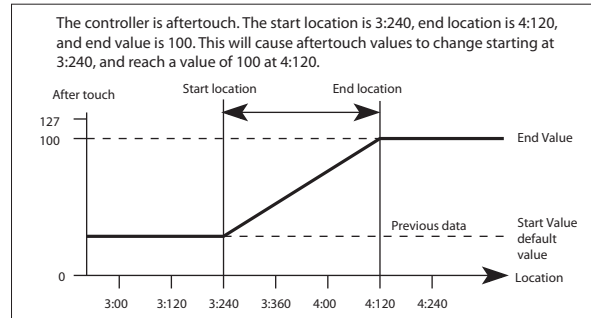

Executing the Create Control Data command will occupy a large amount of sequencer memory. This means that you may be unable to use the command if there is insufficient memory remaining. In such cases, you should first use the "Quantize" command to delete unneeded control data. Alternatively, you can apply the Quantize command to data that was created by the Create Control Data command.

Quantize

This command corrects the timing of the recorded MIDI data (note data, control change, aftertouch, pitch bend, program change, etc.).

When you use the Quantize command, the performance data will be modified as follows.

- If you use the Quantize command on note data, the timing of each note-on will be corrected, but the length (duration) will not change.
- If you set the quantize resolution to Hi, correction will be applied at the base resolution ($\frac{1}{480}$), meaning that note data will not be affected. For example, continuously varying data such as joystick or aftertouch occupies a large amount of memory, but when you use Quantize, multiple items of such data that change within a single interval of the specified quantize resolution will be combined into a single item, conserving memory. Memory will also be conserved since items of control data of the identical timing and identical value will be combined into one.

Track [01...16]

Specify the track where the Quantize operation will be applied.

From [001:01...999:16]

To [001:01...999:16]

Specify the track where the Quantize operation will be applied.

Kind [Note, Others]

Select the type of performance data (events) that will be quantized.

Note: Note data will be quantized. Use "Bottom" and "Top" to specify the range of notes.

Others: Performance data other than notes will be quantized.

Bottom [C-1...G9]

Top [C-1...G9]

Specify the range of notes. Make these settings if you've set "Kind" to Note. "Bottom" specifies the lowest note and "Top" specifies the highest note. This setting allows you to quantize only specific notes (for example, just the snare notes in a drum track). If you want to apply quantization to all notes, set these to C01 and G9.

Resolution [Hi...1/4]

Specify the timing interval where data will be adjusted.

A coarser resolution will save memory, but will also make the performance data change more abruptly.

Swing [-300%...+300%]

Apply a feel of swing to the rhythm. For example, this lets you easily give a subtle shuffle feel to a "square" 16-beat.

With settings other than 0%, the position of notes at even-numbered beats of the specified "Resolution" will be adjusted to give the rhythm a sense of swing.

With a setting of +100%, notes will be moved 1/3 of the way from intervals of the specified "Resolution." With a setting of +300%, notes at even-numbered beats will be moved all the way to the position of the next odd-numbered beat.

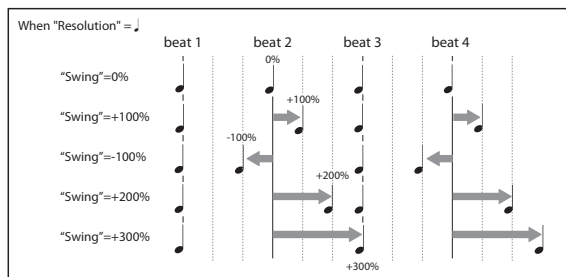

Edit Tempo

This command edits the tempo data of the master track.

Mode [Create, Erase]

Specify how the master track will be edited.

Create: Tempo data will be created in the specified region.

Erase: Tempo data will be erased from the specified region.

From [001:01...999:16]

To [001:01...999:16]

Specify the region in which tempo data will be edited.

If "Mode" is Erase, this specifies the region from which tempo data will be erased.

If "Mode" is Create, this specifies the region in which tempo data will be created.

Start [030.00...300.00]

End [030.00...300.00]

When "Mode" is set to Create, these fields specify the starting and ending values of the tempo data that will be created. (See "Start Val (Start Value)" on page 44)

Edit Time Sig.

This command edits the time signature setting of the master track.

M [001...]

Specify the measure whose time signature will be changed.

TS [1/4...16/16]

Specify the time signature.

Knob Assign

Here, you can assign the functions (mainly types of control change) that knobs 1-4 will have when RealTime Control B mode.

Knob 1B [Off, ...MIDI CC#119]

Knob 2B [Off, ...MIDI CC#119]

Knob 3B [Off, ...MIDI CC#119]

Knob 4B [Off, ...MIDI CC#119]

The functions you assign here are active when you use the REALTIME CONTROLS SELECT button to select B mode, and operate knobs 1-4.

For more information, please see "Realtime Control Knob 1-4 Assign" on page 294.

Tempo

This specifies the tempo of the song. Song playback, arpeggiator, LFOs, and effects can be synchronized to the tempo you specify here.

♩(Tempo) [040.00...300.00, EXT]

Specify the tempo. (See "♩(Tempo)" on page 31)

ARP (Arpeggiator)

Here, you can specify how the arpeggiator will operate in Sequencer mode. These settings can be made for each song. In Sequencer mode (as in Combination mode), you can run the two arpeggiators simultaneously.

This allows you to apply different arpeggio patterns to two sounds that have been split across the keyboard, or use velocity to switch between two different arpeggio patterns, etc.

In Sequencer mode you can record the performance data that's generated by the arpeggiators. When doing so, you can change the arpeggio pattern or parameters while you record, and select Realtime Control C mode and operate the knobs to modify the arpeggio pattern.

It is not possible to set independent tempos for the arpeggiator and the sequencer.

When MIDI Clock (See "Clock (MIDI Clock Source)" on page 62) is Internal, the arpeggiator can be synchronized to the internal sequencer.

- When you turn on the arpeggiator and press the START/STOP button, the arpeggiator will synchronize with the sequencer.
- When you press the START/STOP button, the arpeggiator and sequencer will both stop. If you wish to stop only the arpeggiator, press the ARP ON/OFF button to turn off.

When the arpeggiator "Key Sync" is off, you can turn on the ARP ON/OFF button and play the keyboard to start the arpeggiator during the pre-count before realtime recording begins. That way, the arpeggiator performance will be recorded from the beginning of the pattern when recording starts.

If MIDI Clock Source (See "Clock (MIDI Clock Source)" on page 62) is set to Ext.MIDI or Ext.USB, you can control this in the same way by using MIDI realtime clock commands received from an external MIDI device connected to the MIDI IN or USB connector. In this case,

sequencer start/stop can also be controlled using the microSTATION sequencer's START/STOP button.

ARP-A Setup

Run	[Off, On]
Pattern	[P0...P4, 0000 (INT)...1023(INT), 1024 (USER)...1151(USER)]
Octave	[1, 2, 3, 4]
Resolution	[♩ ₃ , ♩, ♩ ₃ , ♩, ♩ ₃ , ♩]
Gate[%]	[000...100, Step]
Velocity	[001...127, Key, Step]
Swing[%]	[-100...+100]
Sort	[Off, On]
Latch	[Off, On]
Key Sync	[Off, On]
Keyboard	[Off, On]
Top Key	[C-1...G9]
BottomKey	[C-1...G9]
Top Vel	[001...127]
BottomVel	[001...127]

These are the arpeggiator A parameters for the song.

For more information, please see "ARP Setup" on page 9, "ARP (Arpeggiator)" on page 23.

ARP-B Setup

Here you can make settings for the other arpeggiator (arpeggiator B). The parameters are the same as for arpeggiator A (ARP A).

For more information, please see "ARP Setup" on page 9.

IFX1, IFX2, IFX3, IFX4, IFX5

Here you can adjust the settings for the insert effects. These consist mainly of the following.

- Select the effect type for each insert effect 1–5, and set the effect parameters.
- Turn each insert effect 1–5 on/off.
- Specify how the insert effects are connected, and adjust the mixer settings for the signals that have passed through the insert effects.

For the insert effects, the direct (Dry) sound will always be stereo-input/output. The input/output structure of the effect (Wet) sound will depend on the type of effect (☞ "In/Out" on page 208).

The following parameters are the same as in Program mode. (☞ "IFX1, IFX2, IFX3, IFX4, IFX5" on page 11)

However, insert effect dynamic modulation (Dmod) and the "Pan (CC#8)," "Send 1," and "Send 2" parameters that follow the insert effect will be controlled by the MIDI channel specified by "Ch (Control Channel)," unlike in Program mode. The control changes used are the same as in Program mode. (☞ "IFX1" on page 11)

The pan (CC#8), send 1 and 2 settings you make here will be used when the song is played or recorded from the beginning. If you change the settings while recording a MIDI track, the changes will be recorded as part of the musical data, and the settings will change when the data is played back. You can also change these settings during playback.

However if pan (CC#8), send 1, or 2 data has been recorded, the settings will change accordingly.



If "Status" is either INT or BTH, CC#8, CC#93, and CC#91 can be received to control the pan following the insert effect, send 1, or send 2 respectively, and change their settings. When you switch songs or return to the beginning of the song, tracks whose Status is BTH, EXT, or EX2 will transmit these settings via MIDI. Messages are transmitted and received on the MIDI channel specified by the "Ch (Control Channel)" setting of each insert effect. (☞ Global/Media: MIDI- SEQ Mode "Trk" p.62)

IFX1

Here you can edit the effect parameters for insert effect 1.

IFX Select [S00...S63, D01...D10]

This selects the effect type for insert effect 1. (☞ "IFX Select" on page 11)

IFX Parameters

Here you can set the parameters for the effect that's selected by "IFX Select." (☞ "IFX Parameters" on page 11)

For details on the effect parameters, please refer to "Effect Guide" (☞ p.217).

On/Off [Off, On]

Switches the insert effect on/off.

See "On/Off" on page 11.

Ctrl Ch (Control Channel) [Ch01...16, G ch, All-R]

This parameter specifies the MIDI channel that will be used to control effect dynamic modulation (Dmod), pan following the insert effect (CC#8), Send 1, and Send 2.

For more information, please see "Ctrl Ch (Control Channel)" on page 25.

ChainTo [IFX2...IFX5]

Chain [Off, On]

Pan (CC#8) [L000...C064...R127]

Bus (Bus Select) [Off, L/R]

FXCtrl Bus (FX Control Bus) [Off, 1, 2]

Send1 [000...127]

Send2 [000...127]

See "IFX1" on page 11.

IFX2, IFX3, IFX4

Here you can edit the effect parameters for insert effects 2–4. See "IFX2, IFX3, IFX4" on page 12.

IFX Select [S00...S61, D01...D09]

This selects the effect type for insert effects 2–4.

See "IFX Select" on page 12.

IFX Parameters

Here you can set the parameters for the effect that's selected by "IFX Select." For details on the effect parameters, please refer to "Effect Guide" (☞ p.217).

On/Off [Off, On]

Switches the insert effect on/off.

See "On/Off" on page 11.

Ctrl Ch (Control Channel) [Ch01...16, G ch, All-R]

This parameter specifies the MIDI channel that will be used to control effect dynamic modulation (Dmod), pan following the insert effect (CC#8), Send 1, and Send 2.

For more information, please see "Ctrl Ch (Control Channel)" on page 25..

ChainTo [IFX3...IFX5]

Chain [Off, On]

Pan (CC#8) [L000...C064...R127]

Bus (Bus Select) [Off, L/R]

FXCtrl Bus (FX Control Bus) [Off, 1, 2]

Send1 [000...127]

Send2 [000...127]

(☞ "IFX1, IFX2, IFX3, IFX4, IFX5" on page 11)

IFX5

Here you can edit the effect parameters for insert effect 5.

See "IFX5" on page 12.

IFX Select [000...61]

This selects the effect type for insert effect. IFX5 cannot use double-size effects.

IFX Parameters

Here you can set the parameters for the effect that's selected by "IFX Select." For details on the effect parameters, please refer to "Effect Guide" (☞ p.217).

On/Off [Off, On]

This turns the insert effect on and off.

See "On/Off" on page 11.

Ch (Control Channel) [Ch01...16, G ch, All-R]

This parameter specifies the MIDI channel that will be used to control effect dynamic modulation (Dmod), pan following the insert effect (CC#8), Send 1, and Send 2.

For more information, please see "Ctrl Ch (Control Channel)" on page 25..

ChainTo [IFX3...IFX5]

Chain [Off, On]

Pan (CC#8) [L000...C064...R127]

Bus (Bus Select) [Off, L/R]

FXCtrl Bus (FX Control Bus) [Off, 1, 2]

Send1 [000...127]

Send2 [000...127]

See "IFX5" on page 12.

MFX1, MFX2

Here you can adjust settings for the master effects. These consist mainly of the following.

- Select the effect type for each master effect, and set the effect parameters.
- Turn each master effect on/off.
- Specify how the master effects are connected, and specify the level at which the signal from the effects are returned to the L/R bus.

The following parameters are the same as in Program mode. (☞ "MFX1, MFX2" on page 13)

MFX1, MFX2

MFX Select [S00...S87, D00...D13]

MFX Parameters

MFX On/Off [Off, On]

See "MFX1, MFX2" on page 13.

Ch (Control Channel) [Ch01...16, G ch, All-R]

See "Ctrl Ch (Control Channel)" on page 25.

Return 1 [000...127]

Chain On/Off [Off, On]

Chain Level [000...127]

See "MFX1, MFX2" on page 13.

TFX (Total Effect)

Here you can adjust settings for the total effect, which is located at the final stage of the L/R bus. These consist mainly of the following.

- Select the effect type for the total effect, and set the effect parameters.
- Turn the total effect on/off.

The following parameters are the same as in Program mode. (☞ "TFX" on page 13)

TFX

TFX Select [000...61]

TFX Parameters

See "TFX" on page 13.

Ch (Control Channel) [Ch01...16, G ch, All-R]

See "Ctrl Ch (Control Channel)" on page 25.

TFX On/Off [Off, On]

See "TFX" on page 13.

Master Vol

Master Vol (Master Volume) [000...127]

This specifies the final level of the audio output that has passed through total effect, and output from OUTPUT L/MONO and R.

Command

Copy ARP

This command copies arpeggio settings.
See “Copy Arpeggio” on page 14, 27.

Copy IFX

This command copies effect settings from a specified program, combination, or song (☞ “Copy IFX” on page 14).
However, the “Ch (Control Channel)” setting is not copied.

Swap IFX

This command swaps (exchanges) the settings of two insert effects (☞ “Swap IFX” on page 14).
However, the “Ch (Control Channel)” setting is not swapped.

Copy MFX/TFX

This command copies effect settings from a specified program, combination, or song (☞ “Copy MFX/TFX” on page 14).
However, the “Ch (Control Channel)” setting is not copied.

Song Command

These commands let you perform song operations such as creating a new song, copying a song, or renaming a song. Set the parameters as desired, access the “OK?” prompt, and then press the ► button to begin.

Memory Status

This displays the remaining amount of sequencer memory.

Create New (Create New Song)

This command creates a new song.

Length [001...999]

Specify the length of the song that will be created, as a number of measures.

Note: If you want to change the length after creating a song, use the Track Edit command “Set Song Length” (☞ p.42).
When creating a new song, you can set the song length to be longer than you expect to need, and then use “Set Song Length” to re-specify the length when you’ve finished recording and editing.

Rename (Rename Song)

Here you can edit the name of the song. Use the ◀▶ buttons to select a character, and use the ▲▼ buttons to specify the desired character. You can enter up to twenty-four characters.

Delete (Delete Song)

This command deletes the currently selected song.

When you use this command, the musical data, setting data, and effects settings etc. of the currently selected song will be erased, and the memory area allocated to that song will be freed.

Copy Song (Copy From Song)

This command copies all settings and performance data from a specified song to the song that’s currently selected. When you use this command, the settings and performance data of the currently selected song will all be deleted and overwritten by the copy-source data.

From [S000...]

Select the copy-source song.

Load Template

This command loads a template song.
The built-in sequencer contains sixteen different preset template songs (P00–15) that contain settings for programs and effects appropriate for various musical styles. You are also free to create your own favorite settings for programs, track parameters, and effects, and save them as one of sixteen user template songs (U00–15). (☞ “Save Template” on page 48)

From [P00...P15, U00...U15]

Select the template song that will be loaded.

Note: A drum category program is assigned to track 1 for each of the sixteen preset template songs.

Save Template

This command saves the program selections, track parameters, and effect settings etc. of the current song as a user template song U00–15.

To [U00...U15]

Select the user template song (U00–15) that will be the save-destination. When you select the command, all settings of the save-destination user template song will be deleted and overwritten.

FF/REW Speed

This allows you to set the speed at which fast-forward or rewind will occur when you press the ►► (FF) button or ◀◀ (REW) button.

Speed [1...4]

Specify the speed of fast-forward and rewind.

This setting is relative to the playback tempo. A setting of 1 is the same speed as the playback tempo. Settings of 2–4 are respectively two times, three times, or four times the playback tempo.

Note: The fast-forward or rewind speed may be slower in areas where the performance data is concentrated. The fast-forward and rewind speeds will differ depending on whether an area contains densely packed performance data.

IgnoreTmpto (Ignore Tempo) [Off, On]

If this is On, fast-forward and rewind will ignore the playback tempo and the duration of the notes.

The fast-forward and rewind speeds will differ depending on whether an area contains densely packed performance data.

If this is Off, fast-forward and rewind will occur at the speed specified by “Speed.”

Location Point

When you press the LOCATE button, you will move to the location specified here.

Loc (Location) [001: 01...999: 16]

This specifies the location where you'll move when you press the LOCATE button.

From the left, the values indicate the measure (001–999) and beat (01–16).

If you set this to 001:01 and press the LOCATE button, you'll return to the beginning of the song.

Note: When this dialog box is not open, you can hold down the WRITE button and press the LOCATE button to assign the current location as the "Loc" value.

GM Initialize

This command transmits a GM System On message to the Sequencer mode, resetting all tracks to the GM settings.

Please see "GM Initialize List" below.

MIDI In Sequencer mode, when a GM System On message is received from an external device, or if a GM System On message is recorded in the sequence data, the microSTATION will be reset to settings appropriate for GM just as if you had executed this command. However, in these cases, the various master effects and total effect parameters will not be reset.

GM Initialize List

	Page	Parameter	Track 1–9, 11–16	Track 10	
Track Parameter	EDIT-Tracks	Program Select	G001*	g(d)001*	
		Play/Mute	-	-	Setting remains unchanged
		Pan	C064	C064	
		Volume	100	100	
		Bus	L/R	L/R	
		Send1	0	0	
		Send2	40	40	
		FXCtrl Bus			
		ARP Assign		-	Setting remains unchanged
		Status		-	Setting remains unchanged
		MIDI Ch.		-	Setting remains unchanged
		OSC Mode		-	Setting remains unchanged
		Portamnto		Off	Off
		Transpose		+00	+00
		Detune		+0000	+0000
		Bend Range		+02	+02
Key Zone		C-1...G9 (Slope=000)	C-1...G9		
Vel Zone		001...127 (Slope=000)	001...127		
MIDI Filter		On	On		
Arpeggiator	ARP	Various parameters		-	Setting remains unchanged
IFX	IFX1 IFX2 IFX3 IFX4 IFX5	Effect Type	-	-	Setting remains unchanged
		Pan: #8	-	-	Setting remains unchanged
		FXCtrl Bus	-	-	Setting remains unchanged
		Send1, Send2	-	-	Setting remains unchanged
		Other parameters	-	-	Setting remains unchanged
MFX	MFX1 MFX2	MFX1 Effect Type	-	-	St.Chorus
		MFX2 Effect Type	-	-	Reverb Smooth Hall
		Chain	-	-	Off
		Level	-	-	127
		Return1	-	-	127
		Return 2	-	-	50
MFX Other parameters	-	-	Setting remains unchanged		
TFX	TFX	-	-	-	Setting remains unchanged
Master Volume	Master Vol	-	-	-	Setting remains unchanged

*: Appropriate programs from the KEYBOARD–DRUMS/MALLET/HITS categories are assigned to each track.

Copy Combi (Copy from Combination)

This command copies the parameters of the specified combination to the setting data of the song that's currently selected.

Note: Only the timbres used by the combination will be copied. Timbres in the combination whose "Status" is Off will not be copied. If any timbres are set to Mute, the corresponding tracks of the song will be set to a "Status" of Off.

with FX? [No, Yes]
Specifies whether the combination's effect settings will be copied.

Multi Rec? [No, Yes]
Specifies whether the track settings will be adjusted or tracks added so that the same performance and sound will be reproduced during playback as when you were multi-recording with the arpeggiators on.

Note: This setting compensates for the state of the arpeggiators in the combination. When copying a combination that was written with the arpeggiators turned off, it is assumed that the arpeggiators will be off in the song as well. If you want the arpeggiators to be on in the song, write the combination with the arpeggiators turned on, and then copy it to your song.

If this is Yes, the MIDI channels and other settings of the track will be adjusted. The recording track and the "Play/Mute" setting (p.37) will also be set automatically. "M (Recording Mode)" (p.34) will be set to OVW (Overwrite). (Be aware that the automatically-specified recording track and "Play/Mute" settings will be reset when you re-select the song.)

Note: See below for details on the settings that are adjusted. The settings listed here will be adjusted automatically. Depending on the settings of the combination, it may be necessary to make other changes to the track settings in addition to those listed here.

If the recorded performance is not reproduced correctly during playback

If you use the song command "Copy Combi" to copy the settings of a combination, and then perform multi-track recording with the arpeggiator turned on, there may be cases in which the performance during recording is not reproduced correctly during playback.

Multiple tracks that are set to the same MIDI channel are combined into a single stream of performance data during recording. If there is a track with the same MIDI channel as the track being played by the arpeggiator, the data played by the arpeggiator will be combined with the performance data that was played manually, and all of this data will be sounded by each track of the same channel (if "Status" is INT).

In such cases, you can solve the problem by creating a track that will drive the arpeggiator on a different MIDI Channel. If the recorded performance is not reproduced by the playback, check the following conditions.

The settings described here will be done automatically if you select "Copy Combi" with "Multi Rec?" set to Yes. Normally you will use the Yes setting when executing this command. In this case, the corrections described here will not be necessary, but you can view these automatically applied corrections here.

- "ARP Assgin" setting (p.37)

Track	T01	T02	T03	T04	T05	T06	T07	T08
Assign	Off	B	Off	A	Off	A	Off	Off

- "MIDI Ch." settings (p.39)

Track	T01	T02	T03	T04	T05	T06	T07	T08
Status	INT	INT	INT	INT	INT	Off	INT	Off
MIDI Ch.	01	01	01	02	01	01	01	01

1. If Arpeggiator Run A and B are turned on, and the arpeggiator is assigned to a track, make sure that global MIDI Channel (p.60) is set to other than 01. Make sure that the global MIDI channel is set to 01.

Arpeggiator Run	MIDI Channel 1*	Correction
If either "A" or "B" are checked	01 only	Correction required
	01 02, 01 03, etc.	No correction required
If both "A" and "B" are checked	01 only	Correction required
	01 02, 01 03, etc.	Correction required for only one
	01 02 03, etc.	No correction required/Correction required 2*

1* If the "MIDI Channel" of multiple tracks operated by the arpeggiator is set only to 01, refer to the lines for "01 only." If the "MIDI Channel" settings are 01 and one other channel, such as 01 and 02, then refer to the lines for "01 02, etc." If the "MIDI Channel" settings are 01 and multiple other MIDI channels, such as 01 and 02 and 03, then refer to the line for "01 02 03, etc."

2* Correction is necessary only if the tracks operated by a single arpeggiator are using only "MIDI Channel" 01. In some cases, correction may also be necessary if the two arpeggiators use the same MIDI channel.

⚠ Depending on the combination settings, it may also be necessary to change the track settings as well.

The preceding illustration shows the example of copying the combination Category: BASS & BASS SPLIT 032: Echo Jam with "Multi REC" is set to Yes in Copy Combi. Select a new song, and select the copy to see the result. (For more about the arpeggiator settings in this combination, see page p.23)

Using these settings as an example, determine whether correction is necessary, and if so, what needs to be corrected.

Arpeggiator Run A and B are turned on, and MIDI Channel 01 and 02 are selected. Correction is necessary for one of the arpeggiators. If you perform multi-track recording with these settings, the MIDI channels of T01, 02, 03, and are the same, so the high-register guitar (T02), the low-register bass (T01) played by arpeggiator B (T02) will have their performance data combined into one stream, and the performance will not be reproduced at playback. (T06 is a dummy track used to trigger arpeggiator A.)

1. So that the bass played by arpeggiator B can be recorded separately, change the MIDI channel of T03. Change the T02 MIDI Channel to 03.

2. Add settings for triggering arpeggiator B. For track 8 (or any unused track), turn "Status" Off, and set the MIDI Channel to 01. (T08 will be a dummy track used to trigger arpeggiator B.)

3. Set the track 8 Assign to B. This will produce the following settings

Track	T01	T02	T03	T04	T05	T06	T07	T08
Assign	Off	B	Off	A	Off	A	Off	B
Status	INT	INT	INT	INT	INT	INT	INT	Off
MIDI Ch.	01	03	01	02	01	01	01	01

This completes the adjustments. With the front panel TIMBRE/TRACK LED lit, use the function buttons 01-16 to select the track whose MIDI channel is 01. Select track 1

through 8 as the recording track, and proceed with multi-track recording.

Copy Prog (Copy from Program)

This command copies settings from the program you specify to the song that's currently selected.

This is the same function as in Combination mode; for details, please see "Copy Prog (Copy from Program)" on page 27

This command in Sequencer mode differs from its behavior in Combination mode in that the channels assigned to the tracks of the song will be preserved regardless of the "With Arp?" setting of the copy-destination track's "MIDI Ch."

External Setup

You can use the microSTATION's external control functionality to control an external MIDI device; press the EXTERNAL button and use knobs 1–4 to transmit MIDI control change messages on the specified MIDI channel.

Setup Select [000...127: name]

This selects the setup that will be used for external control. You can choose from 128 setups.

Preload setup data is loaded when the microSTATION is shipped from the factory. For example, these include setups that let you control the Korg Legacy Collection of software synthesizers, and setups that let you control DAW software.

For more information, please see "microSTATION External Setup (PDF)"

You can use Global/Media: MIDI - External Setup to assign the function of each knob in an external setup (p.64).

1	[MIDI ch/MIDI CC#: Knob value]
2	[MIDI ch/MIDI CC#: Knob value]
3	[MIDI ch/MIDI CC#: Knob value]
4	[MIDI ch/MIDI CC#: Knob value]

These indicate the assignments for knobs 1–4 in the selected external setup. From the left, these are the MIDI channel / MIDI control change / current knob value. The knob value can be edited.

Grid Seq (Grid Sequence)

When the sequencer is stopped, you can press the GRID SEQ button to use the Grid Sequence function. This lets you easily create drum patterns etc. by using function buttons 01–16 to turn each step of a grid on/off. When you play back the sequencer, the function 01–16 LEDs will light-up in synchronization with the sequencer, allowing you to view the drum pattern etc. you created.

Note: You can't turn grid notes on/off during playback or recording.

What is the grid?

The following illustration shows one measure of an 8-beat pattern with all steps of the grid turned off.

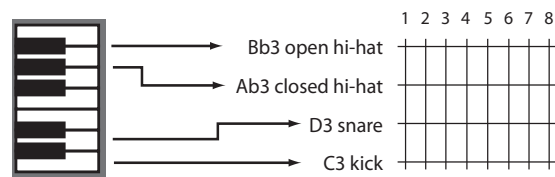

- The vertical lines indicate 8th notes. Since the illustration shows one measure, there are eight vertical lines.
- Notes (note numbers) are indicated by horizontal lines. The four horizontal lines here correspond to four drum sounds.
- Each intersection between a vertical and horizontal line is a possible note on the grid.

You can create a drum pattern by turning on (adding a "●" symbol at) grid steps where you want each instrument to sound.

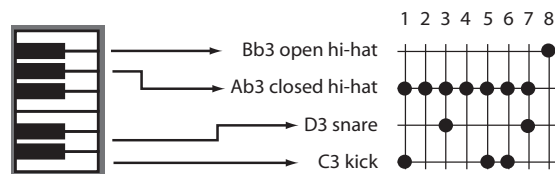

About the grid sequence Compare function

The Compare function is available when the grid sequence is off. When you press the COMPARE button to turn Compare on (the LED will light-up), you'll return to the state immediately prior to when you turned Grid Sequence on.

When grid sequence is on, the COMPARE button is unavailable; the Compare operation cannot be used.

Here's an example of using this function.

1. Start with grid sequence turned off.
2. Turn grid sequence on, and create a hi-hat pattern.
3. Turn grid sequence off.
4. Press the COMPARE button to turn Compare on (LED lit).
You'll return to the state of step 1.
5. Press the COMPARE button to turn Compare off (LED unlit).
You'll be in the state following step 2, with the hi-hat pattern having been created.
6. Turn grid sequence on, and create the snare pattern.
7. Turn grid sequence off.
8. Turn Compare on (LED lit).
You'll return to the state following step 2, with the hi-hat pattern having been created.
9. Turn Compare off (LED unlit).
You'll be in the state following step 6, with the snare pattern having been created.

Grid Sequence Parameters

When you press the GRID SEQ button to turn Grid Sequence on, the GRID SEQ group page will appear. The upper line shows the name of the key (the grid key) whose grid steps you're editing, and the loop region.

```
GRIDIC#41001-002
└─┬─End:002 Q:♪ >
```

Grid key: [C3 (C-1...C9)]

[C3]: If there are note events in the loop region, the key is shown in square brackets [].

(C3): If there are no note events in the loop region, the key is shown in parentheses ().

You can select the grid key by holding down the KEY button and playing a note on the keyboard.

Loop region: 001-002

This indicates the loop region. When grid sequence is on, playback of all tracks will loop according to this setting. The number at the left is the loop start measure, and the number at the right is the loop end measure.

The lower line of the display shows grid sequence setting parameters.

Loop End, Quantize

LpEnd (Loop End)

[001...999]

This specifies the last measure that will be looped.

The grid is limited to a maximum of 64 steps. This means that the range that you can select is limited by the loop start measure, "Q (Quantize)," and "TS (Time Signature)" settings.

- If the loop start is M001, "TS" is 4/4, and "Q" is 8th, you can specify up to measures 1-8 (eight measures).
- If the loop start is M016, "TS" is 4/4, and "Q" is 8th, you can specify up to measures 16-24 (eight measures).
- If the loop start is M001, "TS" is 4/4, and "Q" is 16th, you can specify up to measures 1-4 (four measures).

Note: Loop Start is set automatically according to the loop start setting of SEQ: PLAY-LOOP-P or SEQ: REC-LOOP-R when loop is turned on or grid sequence is turned off. If you want to change this setting, turn loop on, turn grid sequence off, and make the setting in the PLAY or REC group (p.34).

Note: The "TS" setting will use the setting of the PLAY or REC group made when grid sequence is off. If you want to change this setting, you can do so in the PLAY or REC group (p.35).

Q (Quantize)



Specify the note value of each grid step. This setting is linked with the quantize setting of the PLAY or REC groups (settings other than Hi).

Note: If you change the "LpEnd" or "Q" setting, the grid LEDs for which input is now possible will light-up for an instant.

Example: Loop: 001-002 (two measures), TS: 4/4, Q: 8th

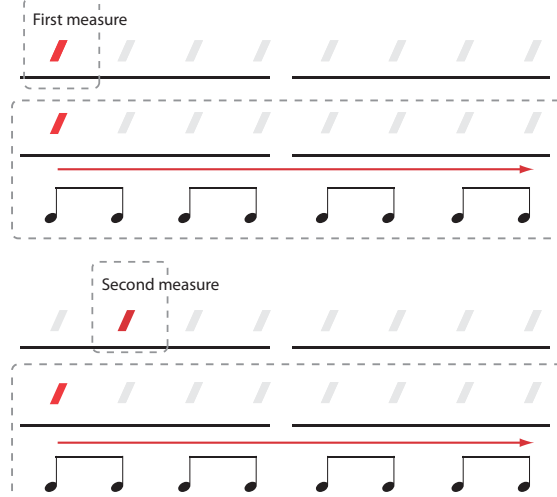

The lower row of function LEDs (09-16) indicate the grid (note values).

The upper row of function LEDs (01-08) indicate the location. In this example it indicates the measure, but the location indicated will differ depending on the settings.

When you press a function button 01-08, the grid LEDs that allow input for that measure (location) will light-up for an instant.

Example: Loop: 001-002 (two measures), TS: 4/4, Q: 16th

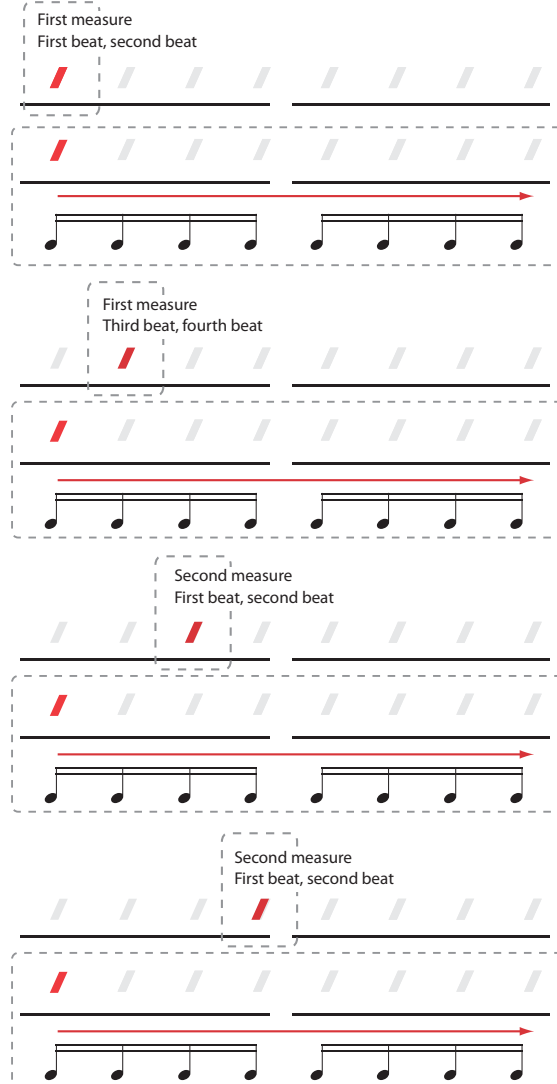

Tempo, Tempo Mode

```
GRID[C#4]001-002
◊Tempo:120.00 :Manu>
```

Tempo [040.00...300.00, EXT]

Set the tempo of the song. This will also change the speed at which the function button 09–16 LEDs light during playback. (☞“(Tempo)” on page 31)

Tempo Mode [Auto, Manu]

Specify the tempo setting of the song. (☞“Tempo Mode” on page 31)

Initial Velocity

```
GRID[C#4]001-002
◊Init Vel :100 >
```

Init Vel (Initial Velocity) [001...127]

Specify the initial velocity for the grid note. When you turn a grid note on, the value you specify here will be input for that note.

Note: You can select the key of the grid note by holding down the KEY button and playing the keyboard. If “Vel” is set to AsPlayed, the velocity with which you play the keyboard will automatically be set as the “Init Vel” value. (☞“Vel (Velocity)” on page 53)

Note: Changing this setting after turning a grid note on will not affect the previously-input grid note. If you want to perform grid input with the new setting, turn that grid note off, and then on again. The velocity value of a grid note can be edited in the Grid Edit page even after that grid note is turned on. (☞“Grid Edit” on page 53)

Initial Duration

```
GRID[C#4]001-002
◊Init Dur :100%>
```

Init Dur (Initial Duration) [1%...100%]

Specify the initial value for the duration of the grid notes you input. When you turn a grid note on, this value will be input as its duration. Normally when using a drum program, the duration value will not affect the actual duration of the note, so there’s no need to specify this. This setting will be meaningful when you’re using the grid to create a bass phrase.

Note: Changing this setting after turning a grid note on will not affect the previously-input grid note. If you want to perform grid input with the new setting, turn that grid note off, and then on again. The duration value for a grid note can be edited in the Grid Edit page even after that grid note is turned on. (☞“Grid Edit” on page 53)

Grid Key Select

```
GRID[C#4]001-002
◊KeySelect:C#4 >
```

Key Select

[C-1 ... G9]

Select the grid key. Normally you’ll select the grid key by holding down the KEY button and pressing a note on the keyboard, but you can also use this setting to select the key.

This setting is linked with the grid key indication () [] in the upper line of the display.

Velocity Mode

```
GRID[C#4]001-002
◊Vel :as Played>
```

Vel (Velocity)

[As Played, Fixed]

As Played: When you hold down the KEY button and play the keyboard to select the grid key, the velocity with which you play the keyboard will be automatically assigned as the “Init Vel” value. This is convenient when you want to play the keyboard to audition the sound while inputting grid notes. Normally, you’ll leave this set to As Played.

Fixed: The “Init Vel” value will not change when you hold down the KEY button and play the keyboard to select the grid key.

Note: When Grid Sequence is on, you can press the REC button and then the START button to realtime-record. This lets you add conventional keyboard playing to a phrase you recorded using Grid Sequence. Even in this case, the setting you make here will be applied. The notes will be recorded with the keyboard velocity if As Played is selected, or with the “Init Vel” setting if Fixed is selected.

Grid Edit

```
GRID[C#4]001-002
^Grid Edit >
```

```
<[C#4]Vel/Dur
◊1-1 :100/:080%>
```

```
<[C#4]Vel/Dur
◊1-2 :100/:080%>
```

Grid Select

[1-1 ... 8-8]

This selects the grid number.

The number at the left corresponds to the upper line of function buttons and LEDs 01–08.

The number at the right corresponds to the lower line of function buttons and LEDs 09–16.

The grid numbers you can select are limited by the number of loop measures, the “Q” (Quantize)” setting, and the “TS (Time Signature)” setting.

Note: You can also specify the grid key for editing by holding down the KEY button and playing a note on the keyboard.

Example: Loop: 001–002 (two measures), TS: 4/4, Q: 8th

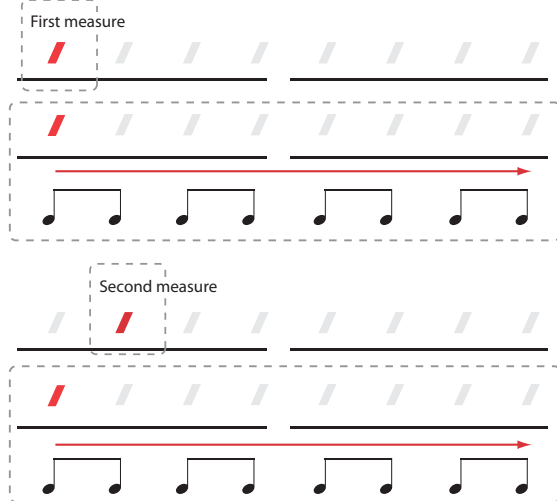

In this example, the following numbers correspond.

First measure: 1-1, 1-2, 1-3, 1-4, 1-5, 1-6, 1-7, 1-8

Second measure: 2-1, 2-2, 2-3, 2-4, 2-5, 2-6, 2-7, 2-8

Example: Loop: 001–002 (two measures), TS: 4/4, Q: 16th

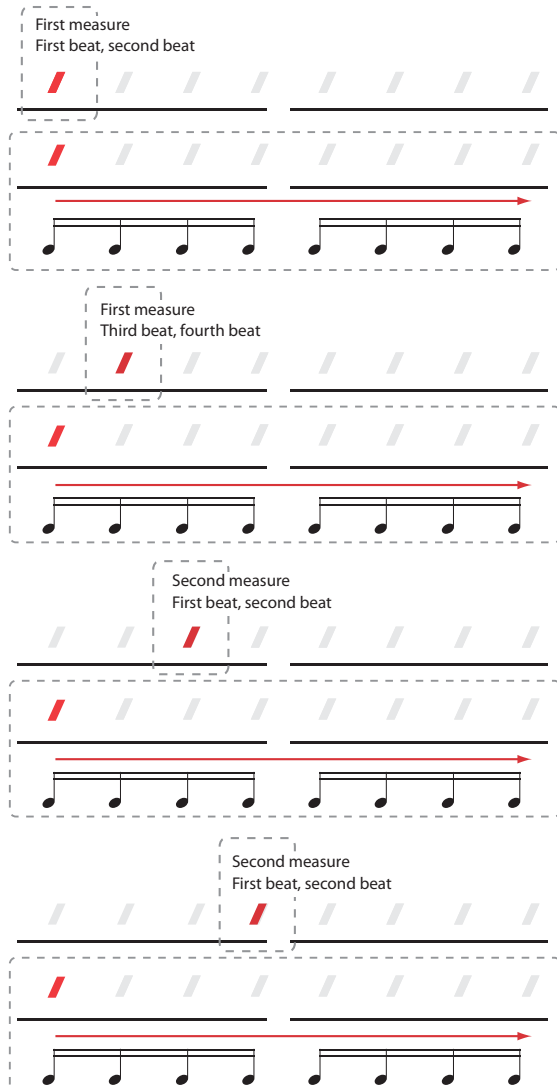

In this example, the following numbers correspond.

First measure, first and second beats: 1-1, 1-2, 1-3, 1-4, 1-5, 1-6, 1-7, 1-8

First measure, third and fourth beats: 2-1, 2-2, 2-3, 2-4, 2-5, 2-6, 2-7, 2-8

Second measure, first and second beats: 3-1, 3-2, 3-3, 3-4, 3-5, 3-6, 3-7, 3-8

Second measure, third and fourth beats: 4-1, 4-2, 4-3, 4-4, 4-5, 4-6, 4-7, 4-8

Vel (Velocity) [---, 001...127, *]**

---: This indicates that the grid note is off. You can also turn a grid note off by changing the grid-on value of 001–127 to ---.

001...127: This indicates the velocity value of a grid note that is turned on. By editing this value, you can (for example) add variation to a pattern that was created by entering hi-hat notes with the same velocity value specified by the “Init Vel” setting.

*******: This indicates that there are multiple note events between grid intervals.

For example if a pattern was created using a “Q” setting of 16th, and you then change the “Q” setting to 8th, there might be two note events within a single grid interval.

Also, if you turn Grid Sequence on for a track that was real-time-recorded, the note events will be converted to a grid. In this case as well, it is possible for two or more note events to exist within a single grid interval.

In such cases, the display shows *** to indicate that two or more note events exist. If you change *** to 001–127 at this time, the two or more note events will be deleted, and a new grid note will be turned on. The two or more note events will become one note event.

Dur (Duration) [---, 001%...999%, Tie, *]**

---: This indicates that the grid note is off.

001%...999%: This indicates the duration of a grid note that is on. You can edit this as long as it does not exceed the measure boundary.

Tie: If you turn Grid Sequence on for a track that was real-time-recorded, the note events will be converted to a grid. In this case, tie events will be shown as a tie grid event.

If you change the “Q” to a finer setting than when the grid note was turned on, thus causing “Dur” to exceed 999%, it will also be shown as a tie grid event.

You cannot change the duration value of a tie grid event.

A tie grid event can be deleted by turning it off.

System Exclusive events supported in Sequencer mode

You can record and play back System Exclusive events, and edit tracks that contain System Exclusive events.

SysEx messages that can be recorded in real-time

The following exclusive messages can be recorded in real-time:

- Exclusive messages received from an external MIDI device.
- Parameter changes in Sequencer mode (see table below).
- Master Volume universal exclusive messages assigned to the foot pedal or a realtime control knob.

Parameter change messages that you can realtime-record in Sequencer mode

Front panel/Page		Parameter
Front panel	ARP	ON/OFF button, LATCH button, ARP GATE knob, ARP VELOCITY knob, ARP SWING knob, TEMPO knob
	REALTIME CONTROLS	SELECT button, EXTERNAL button
Track Param	EDIT-Tracks	Program Select, Volume, Pan, PLAY/MUTE
		OSC Mode, Portamento
		Transpose, Detune, Bend Range
		DKit Patch IFX1,IFX2, IFX3, IFX4, IFX5, Bus, Send1, Send2, FxCtrl Bus
		ARP Assign
Knob Assign		"Realtime Control knob Assign" parameters
ARP	ARP-A Setup	All parameters
	ARP-B Setup	All parameters
IFX1		All effect parameters
IFX2		All effect parameters
IFX3		All effect parameters
IFX4		All effect parameters
IFX5		All effect parameters
MFx1		All effect parameters
MFx2		All effect parameters
TFx		All effect parameters
Master Volume		Master Vol

 The maximum amount of exclusive data that can be recorded at once is approximately 320 Kbytes. This size will decrease if other events exist within the same measure.

 You cannot simultaneously record exclusive messages received from an external MIDI device and parameter changes produced by editing.

 The events that will be recorded are controlled by the Global/Media: MIDI- SEQ MIDI Out "Param." For Control Change, only control change messages will be recorded. For "SysEX," only parameter changes and exclusive messages will be recorded ("Param (Parameter MIDI Out)" on page 62).

 Parameter edits made by executing a song command are not realtime-recorded.

Recording internal parameter changes

You can use SysEx for automation of internal microSTATION effects and Program parameters.

As an example, let's record a short phrase on track 1, add an insert effect, and then record parameter changes for that effect on an unused track.

Note: In order for system exclusive messages to be recorded, the Global/Media: MIDI - MIDI Filter "SysEx" setting must be On. Go to Global/Media mode, and make sure that this setting is On.

1. Select the desired program for MIDI track 1, and send it to insert effect 1. Then record a phrase of about sixteen measures.
 - Use track 1 "Program Select" (p.36) to select the desired program.
 - Set the track 1 "Bus" (p.37) to IFX1, routing the sound to insert effect 1. Then select the desired effect for insert effect 1 (p.46).
 - With the front panel TIMBRE/TRACK LED lit, use the function buttons 01-16 to select track 1. Press REC and

then START/STOP, and record a phrase of about sixteen measures.

2. Use the 01–16 buttons to select track 9, and record a parameter change.

Note: Select an empty track at this point. If you want to record into a MIDI track that already contains recorded data, set “M (Recording Mode)” (p.34) to OVD (Overdub), and then proceed with recording.

- Use the 01–16 buttons to select track 9, press REC, and then press START/STOP to begin recording.
- At the appropriate moment during recording, edit a parameter that can be realtime-recorded.

There are various ways to edit the sound of the track in realtime: you can select a different effect for insert effect 1, edit the effect parameter values, or edit the tone parameters (p.39)

Note: For details on parameters that can be realtime-recorded, refer to “Parameter changes that can be realtime-recorded in Sequencer mode” (p.55).

3. Stop recording.

Note: Exclusive messages are always recorded on the current track that’s selected by the 01–16 buttons. In this example, they will be recorded on MIDI track 9.

4. Access the page of the parameter (e.g., tone parameter) that you realtime-recorded, and play back; the changes you recorded will be reproduced.

Compatibility of the microSTATION’s song data

The following two types of song data can be loaded from media into the microSTATION’s sequencer and played.

Song data that was saved in the microSTATION’s dedicated format

This data is specifically for the microSTATION.

Since this format allows even detailed settings unique to the microSTATION to be faithfully reproduced, we recommend that you use this format to save song data that you intend to play back on the microSTATION.

Standard MIDI file

This format is not able to reproduce the microSTATION’s performance with the complete fidelity that is possible when using the dedicated format (although there will be no problem with typical performances), but is compatible with any other device that supports SMF.

Use Global/Media mode to save or load song data.

Data including exclusive events is also supported.

Exclusive messages received from an external MIDI device, such as XG or GS data, or the parameter changes produced when editing track parameters (“Recording internal parameter changes” on page 55) can be realtime-recorded onto the desired track.

- ⚠ Recorded GM, XG, or GS exclusive messages will not be reproduced on the microSTATION during playback. The recorded data is included in the song data as exclusive events, so it can be saved to or loaded from media as usual. Exclusive messages are also supported for SMF (Standard MIDI File) loading or saving (“Load SMF,” “Save to SMF”). This allows recorded exclusive events to be saved as SMF, or exclusive messages included in SMF to be converted into song data.

Global/Media mode

Global/Media mode is where you can adjust settings for the microSTATION itself, such as the following.

- Settings for the overall tuning, such as master tuning and transpose, and settings such as velocity curve and after-touch curve.
- Effect and arpeggiator on/off status, and memory protect settings.
- MIDI-related settings such as global MIDI channel and MIDI filter, and external setup settings.
- Assignments for a pedal connected to the rear panel.
- Saving various types of internal memory data to an SD card inserted in the microSTATION.
- Loading data from media into internal memory.
- Renaming or deleting files, or formatting media.

Note: If the microSTATION is connected to your computer, you can use the microSTATION Editor/Plug-In Editor application to edit user scales, drum kits, and user arpeggio patterns as well as the parameters that can be edited from the microSTATION itself (p.186).

 If you want to keep the setting you make in Global mode, you must write them before turning the power off. Use the "Write Global" command (p.66).

Page structure in Global/Media mode

The microSTATION's Global/Media mode is organized into the tree structure shown on the following page. (p.58)

For details on how to move between pages, select parameters, and edit their value, refer to the "microSTATION Operation Guide."

Basic

MTune (Master Tune)

[-50cents (427.47Hz)...+50cents (452.89Hz)]

This adjusts the overall tuning of the entire microSTATION in one-cent units (semitone = 100 cents), over a range of ±50 cents. With a setting of 0, the frequency of A4 will be 440 Hz.

 The A4 pitch given here is when Equal Temperament is selected as the scale. If a different scale is selected, A4 may not be 440 Hz.

Transpose [-12...+00...+12]

This adjusts the pitch in semitone steps over a ±1 octave range.

This setting is applied at the location (PreMIDI or PostMIDI) specified by "Convrt (Convert Position)" (p.61).

MIDI number transmitted by the microSTATION

-12	0	+12
24...84 (C1...C6)	36...96 (C2...C7)	48...108 (C3...C8)

Note: If Convert Position is set to PreMIDI, the note numbers transmitted from the microSTATION will be affected by the Key Transpose setting.

 "MTune" can be controlled by the MIDI universal System Exclusive message Master Fine Tuning (F0, 7F, nn, 04, 03, vv, mm, F7: nn=MIDI channel, vv/mm= value).

"Transpose" can be controlled by the MIDI universal System Exclusive message Master Coarse Tuning (F0, 7F, nn, 04, 04, vv, mm, F7: nn=MIDI channel, vv/mm=value).

These messages are received on the global MIDI channel specified by "Channel" (p.64).

In Program, Combination, and Sequencer modes, MIDI RPN messages can be received to control the tuning and transposition of the program or timbre (Combination mode) or track (Sequencer mode). Incoming MIDI RPN Fine Tune messages will make relative adjustments to the tuning specified by the "MTune" setting. MIDI RPN Coarse Tune messages will make relative adjustments to the pitch specified by the "Transpose" setting. In Program mode, these messages will be received on the global MIDI channel specified by "Channel" (p.64), and in other modes they will be received on the MIDI channel specified for each timbre or track. ("Transpose," "Detune" p.20, p.39)

Vel Curve (Velocity Curve)

[1...8]

This specifies the way that the volume and/or tone will change in response to variations in keyboard playing dynamics (velocity).

The curves you can select will depend on the "Convrt (Convert Position)" (p.61) setting. If the setting is PreMIDI, the curve is applied immediately after the keyboard. If the setting is PostMIDI, the curve is applied immediately before the sound generator.

In the case of PreMIDI, your keyboard playing dynamics are modified as shown by transmission curves 1-8 (lower left diagram), and reception is fixed at curve 4 linear (diagram at lower right).

In the case of PostMIDI, your keyboard playing dynamics are transmitted according to transmission curve 4 linear (lower left diagram), and will be interpreted according to reception curve 1-8 (lower right diagram).

If you're using the microSTATION as a MIDI sound module, and want to adjust the overall brightness of the sound, set "Convrt (Convert Position)" (p.61) to PostMIDI and select the appropriate velocity curve.

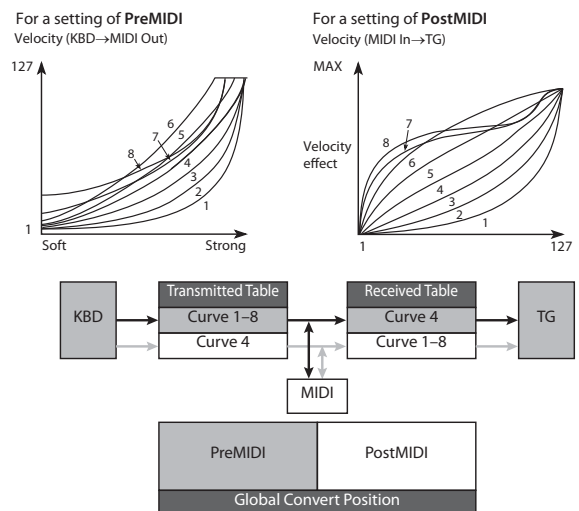

1, 2, 3: Strongly played notes will be affected.

4 (Normal): The normal curve

5, 6: Produces an effect even if you do not play very strongly.

GLOBAL/MEDIA Mode <|>

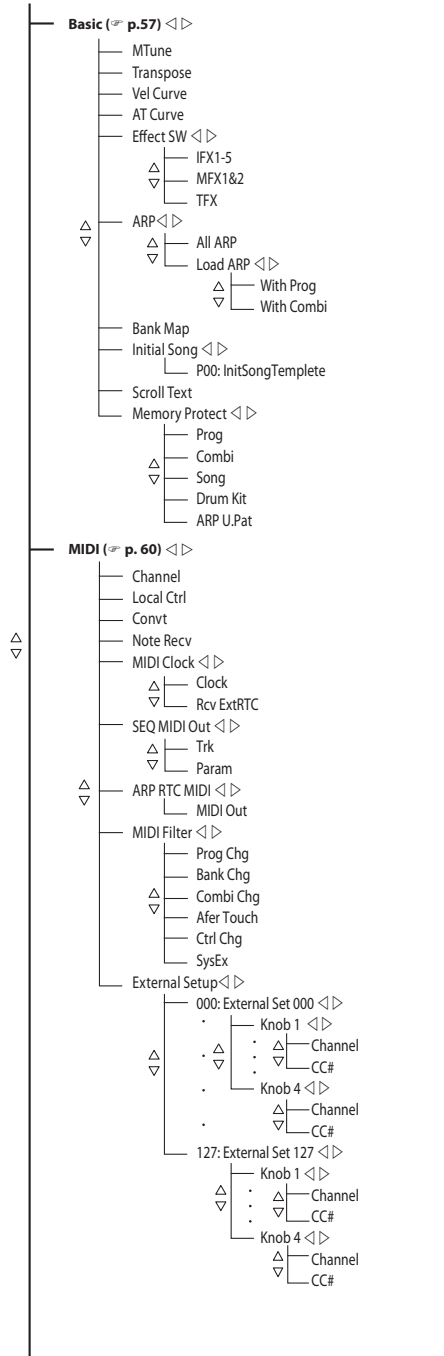

Controllers (≡ p. 65) <|>

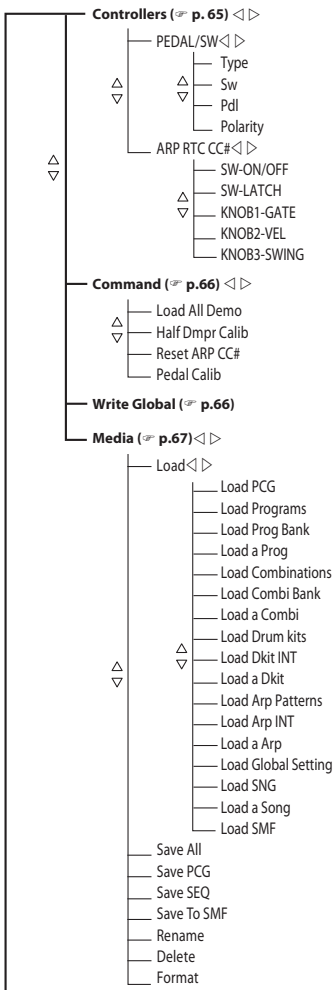

7: This curve produces a relatively consistent effect for softly played notes.

8: This curve produces an even more consistent effect. Each curve has its own characteristics, so you should select the curve that best suits your own playing style and the results you want to obtain.

AT Curve (Aftertouch Curve) [1...8]

This specifies the way that incoming aftertouch data will affect the volume or tone when "Convrt" (Convert Position) is set to PostMIDI.

 This setting has no effect when "Convrt" (Convert Position) is set to PreMIDI.

This curve is applied immediately before the tone generator. The aftertouch Curve setting selects the curve that is applied to the incoming aftertouch.

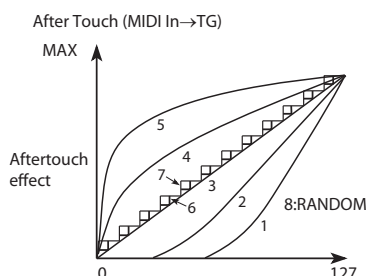

- 1, 2: This curve produces change when strong aftertouch pressure is applied.
- 3 (Normal): The normal curve.
- 4, 5: This curve produces change even when light pressure is applied.
- 6, 7: These curves produce change in 24 or 12 steps. Curve number 7 allows change over twelve steps, so when using aftertouch to modify the pitch, you can set the range of modification to one octave, and use aftertouch to vary the pitch in semitone steps.
- 8: This is a random curve. Use this when you wish to create special effects, or to use aftertouch to apply unpredictable modulation.

However, solely in the case of 0 or 127, the value will not be random; 0 or 127 will be applied constantly

 With a setting of aftertouch, the setting you make here will be applied immediately before the microSTATION's internal tone generator, meaning that it will affect the data received via MIDI, but will not affect the transmitted data.

Effect SW

IFX 1-5 [Off, On]

On: All insert effects IFX1-IFX5 will be off.
Off: The insert effect "On/Off" settings in the IFX1-IFX5 pages of Program, Combination, or Sequencer mode will be used.

MFX1&2 [Off, On]

On: Master Effect1 and 2 (MFX1, 2) will be off.
Off: The master effect "On/Off" settings in the MFX1 and MFX2 pages of Program, Combination, and Sequencer modes will be used.

TFX [Off, On]

On: Total effect (TFX) will be off.
Off: The total effect "On/Off" setting of Program, Combination, and Sequencer modes will be used.

 When "IFX 1-5 Off," "MFX1&2 Off," or "TFX Off" settings are switched, control change messages CC#92 (effect control 2), CC#94 (effect control 4), and CC#95 (effect control 5) will be transmitted respectively. The transmitted data will be 0 for off, and 127 for on.

ARP (Arpeggiator)

All ARP [Off, On]

On: All arpeggiator will be off. The arpeggiator will not operate even if the ARP ON/OFF button is on.
Off: The arpeggiator settings and ARP ON/OFF button settings in Program, Combination, and Sequencer modes will be used.

Load ARP:

With Prog [Off, On]

On: When you switch programs, the arpeggiator settings stored in that program will be used. Normally you will use the On setting.
Off: The arpeggiator settings will not change even if you switch programs. Use this setting if you want to switch Program sounds without changing the phrases from the arpeggiator.

With Combi [Off, On]

On: When you switch combinations, the arpeggiator settings stored in that combination will be used. Normally you will use the On setting.
Off: The arpeggiator settings will not change even if you switch combinations. Use this setting if you want only to switch combination sounds without changing the phrases from the arpeggiator.

Bank Map

Bank Map [KORG, GM(2)]

This specifies the mapping of programs and combinations relative to Bank Select control change messages (CC#0 upper byte and CC#32 lower byte).

The bank select messages shown in the table below will be received (R) and transmitted (T) for Program banks A-D, GM, g(1)...g(9), g(d) and Combination banks A-C.

Bank	Bank Map: KORG	Map: GM(2)
A	00. 00 R/T	63. 00 R/T
B	00. 01 R/T	63. 01 R/T
C	00. 02 R/T	63. 02 R/T
D	00. 03 R/T	63. 03 R/T
GM, g(1)...g(9)	121. 00 R/T, 56. 00 R 121. 01...09 R/T	121. 00 R/T, 56. 00 R, 00. 00 R 121. 01...09 R/T
g(d)	120. 00 R/T, 62. 00 R	120. 00 R/T, 62. 00 R

Initial Song

Initial Song

[P00...P15, U00...U15: name, Initialized]

This selects the template song that will be loaded as the default song settings for Sequencer mode when the power is turned on.

P00...P15: Preload template song. (☞ VNL)

U00...U15: User template song.

Initialized: Initialized song.

Scroll Text

ScrollText

[Off, On]

This specifies whether program names, combination names, and song names will be scrolled if they contain a larger number of characters than can be shown in the display.

Off: Scroll off (default setting).

On: Scroll on.

M.Protect (Memory Protect)

Program

[Off, On]

This setting protects the internal program memory.

On: Internal program memory will be protected, and the following write operations cannot be performed.

- Writing a program
- Loading preloaded program data
- Loading program data from media
- Receiving program data via MIDI data dump

Off: Data can be written to internal program memory.

Combi

[Off, On]

This setting protects the internal combination memory.

On: Internal combination memory will be protected, and the following write operations cannot be performed.

- Writing a combination
- Loading preloaded combination data
- Loading combination data from media
- Receiving combination data via MIDI data dump

Off: Data can be written to internal combination memory.

Song

[Off, On]

This setting protects the internal song memory.

However, when the power is turned off, the song data in song memory will be lost regardless of this setting.

On: Internal song memory will be protected, and the following write operations cannot be performed.

- Recording to the sequencer
- Loading preloaded song data
- Loading song data from media
- Receiving song data via MIDI data dump

Off: Data can be written to internal song memory.

Drum Kit

[Off, On]

This setting protects the internal drum kit memory.

On: Internal drum kit memory will be protected, and the following write operations cannot be performed.

- Writing a drum kit
- Loading preloaded drum kit data
- Loading drum kit data from media

- Receiving drum kit data via MIDI data dump

Off: Data can be written to internal drum kit memory.

ARP U.Pat (Arpeggio User Pattern) [Off, On]

This setting protects the internal user arpeggio pattern memory.

On: Internal user arpeggio pattern memory will be protected, and the following write operations cannot be performed.

- Writing a user arpeggio pattern
- Loading preload arpeggio pattern data
- Loading user arpeggio pattern data from media
- Receiving user arpeggio pattern data via MIDI data dump

Off: Data can be written to internal user arpeggio pattern memory.

MIDI

Here, you can adjust MIDI-related settings that affect the entire microSTATION.

Channel (Global MIDI Channel)

[01...16]

Sets the global MIDI channel. The global MIDI channel is used in the following cases.

- When transmitting and receiving performance data in Program mode (PROG PLAY).
- When selecting combinations via MIDI in Combination mode (COMBI PLAY).
- When controlling timbres or effects that have been set to Gch in various modes
- When transmitting and receiving System Exclusive messages

MIDI received

In Program mode, MIDI data is received on the global MIDI channel, but in Combination mode or Sequencer mode, MIDI data is received on the MIDI channel specified for each timbre or track.

In Combination mode, program changes received on the global MIDI channel will switch the combination (☞ p.63).

Use the global MIDI channel to switch IFX 1–5 (CC#92), MFX1&2 (CC#94) and TFX (CC#95) on/off.

To control the pan following IFX, sends 1/2, MFX 1/2 and TFX, use the global MIDI channel when in the Program mode; while in the Combination, or Sequencer modes, use the channel specified separately by "Ctrl Ch" for IFX1–5, MFX1&2, and TFX. By setting "Ctrl Ch" to Gch, you can control these parameters from the global MIDI channel.

MIDI output when playing the microSTATION

In Program mode, this data will be transmitted on the global MIDI channel. In Combination mode, data will be transmitted simultaneously on the global MIDI channel and on the MIDI channels of timbres whose "Status" (☞ p.20) is set to EXT or EX2.

In Sequencer mode, musical data will be transmitted on the channel specified for the currently selected track (whose "Status" is BTH, EXT, or EX2).

External mode

When the Realtime Controls EXTERNAL is selected in each mode, you can use knobs 1–4 to control a connected software or hardware MIDI device.

The MIDI CC# (control change) messages are transmitted on the MIDI channel specified in the Global/Media: MIDI-External Setup.

Local Ctrl (Local Control) [Off, On]

On: You'll be able to use the microSTATION's knobs, keyboard, or joystick etc. to control the microSTATION's sound generator section. Choose the On setting if you're playing the microSTATION by itself.

Off: The microSTATION's knobs, keyboard, and joystick etc. will be internally disconnected from the tone generator section.

This means that your performance on the microSTATION (i.e., operations of the keyboard or joystick, or the playback of the sequencer) will not produce sound.

Choose the Off setting if echo-back from your external sequencer is causing each note to be sounded twice.

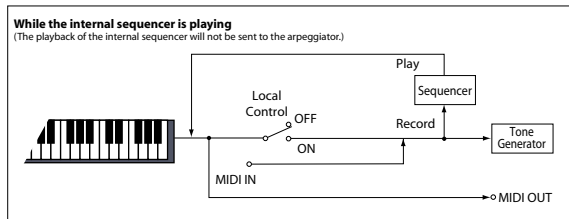
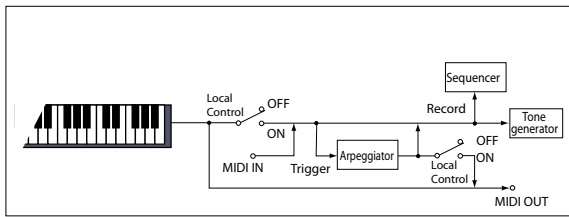

MIDI If Local Control is Off, MIDI transmission/reception will occur normally. Playing the keyboard will cause the corresponding note data to be transmitted, and received note data will play the microSTATION's internal sounds.

Note: Even if Local Control is On, notes played back by the internal sequencer will not trigger the arpeggiator.

Convrt (Convert Position) [PreMIDI, PostMIDI]

This setting specifies the location where the Transpose and Velocity Curve settings will be applied. This setting will affect the MIDI data that is transmitted and received, and the data that is recorded on the internal sequencer.

When using the microSTATION's keyboard to play the internal tone generator, the Transpose, Velocity Curve, and aftertouch Curve settings will always take effect regardless of this setting.

PreMIDI: Velocity Curve, and Transpose will be applied to the data that is transmitted from the microSTATION's keyboard.

This means that the Velocity Curve, and Transpose settings will affect the data that is transmitted from MIDI OUT when the microSTATION's keyboard is played, and the data that is recorded on the internal sequencer.

MIDI data received from MIDI IN or the data played back by the internal sequencer will not be affected.

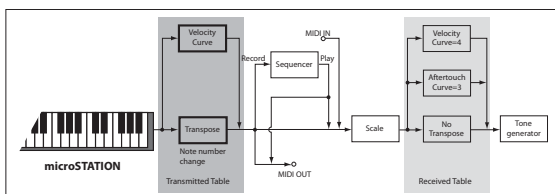

PostMIDI: Velocity Curve, aftertouch Curve, and Transpose will be applied to data before it enters the tone generator.

This means that the Velocity Curve, aftertouch Curve, and Transpose settings will affect the data that is sent to the internal tone generator when you play the microSTATION's keyboard, when the internal sequencer is played back, or when data is received from MIDI IN.

This setting will not affect the data that is transmitted from MIDI OUT or recorded on the internal sequencer when you play the microSTATION's keyboard or play back the sequence.

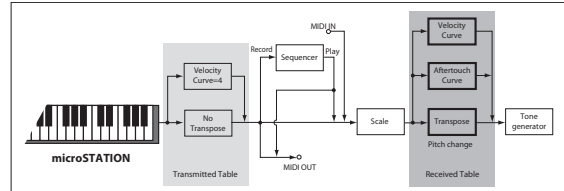

Note Recv (Note Receive) [All, Even, Odd]

This setting specifies whether even-numbered, odd-numbered, or all note numbers will be sounded when note data is received from the microSTATION's keyboard or from an external MIDI device. By connecting the microSTATION to another microSTATION and setting one instrument to Even and the other to Odd, you can effectively double the polyphony by dividing the notes between the two instruments.

All: All note numbers will be received. Normally you will leave this set to All.

Even: Even-numbered notes (C, D, E, F#, G#, A#) will sound.

Odd: Odd-numbered notes (C#, D#, F, G, A, B) will sound.

MIDI This setting has no effect on the MIDI data that is received

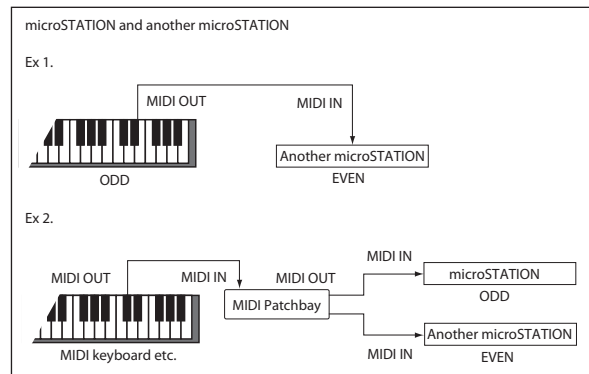

MIDI Clock

Clock (MIDI Clock Source)

[Internal, Ext.MIDI, Ext.USB, Auto]

Use this setting to synchronize the microSTATION's arpeggiator and internal sequencer with an external MIDI device (e.g., sequencer or rhythm machine) and computer.

Internal: The arpeggiator and the internal sequencer will operate according to the internal clock.

Select the Internal setting when using the microSTATION by itself, or when you want the microSTATION to be the master (controlling device) so that connected external MIDI devices will synchronize to the microSTATION MIDI Clock.

Ext.MIDI: The arpeggiator and internal sequencer will operate in synchronization to the MIDI Clock input from an external MIDI device.

Ext.USB: The arpeggiator and internal sequencer will operate in synchronization with the MIDI Clock from a computer (for example a sequencer or DAW application), connected to the USB connector.

Auto: The microSTATION will basically function the same as if you were using the Internal setting. However if external MIDI Clock messages are received from the MIDI IN or USB connector, the microSTATION will automatically switch to Ext.MIDI and Ext.USB.

Note: If you select Auto when an external MIDI sequencer and computer is connected, the microSTATION will automatically switch to Internal operation if the external sequencer is not transmitting MIDI Clock messages, allowing the arpeggiator to operate and parameters for which "MIDI/Tempo Sync" is turned on to function.

Note: If after receiving a MIDI Clock, Start, or Continue message from the MIDI IN or USB connector, no new MIDI Clock message is received within an interval of 500 ms, or if you start the microSTATION's sequencer from the front panel without having received a MIDI Clock, Start, or Continue message from the MIDI IN and USB connector, the microSTATION will automatically switch to Internal operation.

Rcv ExtRTC

(Receive Ext.Realtime Command Clock) [Off, On]

Off: Even if "Clock" is set to Ext.MIDI, or if set to Auto and the microSTATION is synchronized to external MIDI Clock messages, MIDI Common messages and Realtime messages (Song Position Pointer, Start, Continue, Stop) will not be received. (Song Select messages will be received.)

Use this setting if the above messages from an external MIDI sequencer are inadvertently resetting the microSTATION's song settings.

On: The above Common messages (including Song Select) and Realtime messages will be received.



This parameter cannot be set if "Clock" is Internal.

SEQ MIDI Out

Trk (Track MIDI Out)

[for Master, for ExtSeq]

This setting specifies what will be transmitted via MIDI when you switch songs in Sequencer mode.

for Master: Normally in Sequencer mode, the internal sequencer can record or play back a performance on the microSTATION's keyboard. In this case, tracks that are set to EXT or BTH will control external MIDI sound modules. You can adjust settings in a song so that when you select that song on the microSTATION, tracks that are set to EXT or BTH will transmit program changes or other MIDI messages* to set up your external MIDI sound modules.

for External Sequencer: Choose this setting if you want to use the microSTATION in Sequencer mode as a multi-timbral sound module driven by an external sequencer. With this setting, even the tracks that are set to EXT or BTH will not transmit program changes or other MIDI messages* when you switch songs on the microSTATION. This prevents program settings or other parameters for tracks set to the same MIDI channel from being overwritten by the messages echoed-back from your external MIDI sequencer.

* Applicable parameters

- Program Select: CC#00 bank select (LSB), CC#32 bank select (MSB), program change
- Pan: CC#10 pan
- Volume: CC#7 volume
- Portamento: CC#65 portamento On/Off, CC#5 portamento time
- Send 1/2: CC#93 send 1 level, CC#91 send 2 level
- (Post FX) Pan (CC#8) post insert effect pan

Param (Parameter MIDI Out)

[CC, SysEx]

This setting specifies whether control changes or System Exclusive messages will be transmitted when you edit a parameter in Sequencer mode.

CC: Data for the edited parameter will be transmitted as a control change.

SysEx: Data for the edited parameter will be transmitted as a parameter change.

For these to operate, "Ctrl Chg" or "SysEx" (p.63) must be turned on respectively.

* Applicable parameters

- Pan: CC#10 pan
- Volume: CC#7 volume
- Send 1/2: CC#93 send 1 level, CC#91 send 2 level

ARP RTC MIDI

MIDI Out

[CC, SysEx]

This specifies the MIDI messages that will be transmitted when you operate the ARP ON/OFF button, ARP LATCH button, or when you operate knobs 1–4 with Realtime controls C mode selected.

CC: Operating the ARP ON/OFF button, ARP LATCH button, or knobs 1–4 will transmit the MIDI control change messages that are assigned in Global/Media: Controllers–ARP RTC CC# “SW–ON/OFF,” “SW–LATCH,” and “KNOB1–GATE” – “KNOB4– SWING.”

SysEx: Operating the ARP ON/OFF button, ARP LATCH ON/OFF, or knobs 1–4 will transmit MIDI System Exclusive parameter change messages for the parameters (arpeggiator on/off, Latch on/off, Gate, Velocity, Swing) assigned to the buttons and knobs.

MIDI Filter

Prog Chg (Enable Program Change)

[Off, On]

On: Program changes will be transmitted and received.

In Program mode (PROG PLAY), the program will be switched when a program change message is received on the global MIDI channel specified by “Channel” (p.60). When you switch programs, a program change message will be transmitted on the global MIDI channel.

In Combination mode (PROG PLAY), the combination will be switched when a program change message is received on the global MIDI channel. However, it is possible to set the “Combi Chg” parameter so that the combination is not switched. When a program change is received on the channel specified for each timbre by “MIDI Ch.” (p.20), the program of that timbre will be switched. However, the program changes for each timbre will be affected by the setting of the “Prog Chg” parameter (p.22).

When you switch combinations, a program change message will be transmitted on the global MIDI channel, and also transmitted simultaneously on the channel of timbres whose “Status” (p.20) is set to EXT or EX2.

In Sequencer mode, incoming program change messages on a channel that corresponds to a track whose “Status” (p.38) is set to INT or BTH will switch programs on that track.

When you select a song or play back sequencer data, program changes will be transmitted on the channels of tracks whose “Status” is set to BTH, EXT, or EX2. (p.62) (“Trk (Track MIDI Out)” on page 62)

Off: Program changes will not be transmitted or received.

Bank Chg (Enable Bank Change)

[Off, On]

On: The Bank Select control change message will be transmitted together with program change messages. This is valid when “Prog Chg” is turned on.

Off: Bank Select messages will not be transmitted or received.

When recording on the internal sequencer, bank select messages will be recorded regardless of this setting. However for playback, this setting will apply.

Combi Chg (Enable Combination Change)

[Off, On]

On: When in COMBI PLAY, an incoming program change message on the global MIDI channel set by “Channel” (p.60) will switch combinations.

This is valid when “Prog Chg” is turned on.

An incoming program change on a channel other than the global MIDI channel will switch the program of any timbre that matches that MIDI channel.

Off: An incoming program change message on the global MIDI channel will switch the program of any timbre whose “MIDI Ch.” (p.20) matches the global MIDI channel. The combination will not be switched.

The program changes for each timbre will be affected by the setting of the “Prog Chg” parameter (p.22).

AfterTouch (Enable Aftertouch)

[Off, On]

On: MIDI aftertouch messages will be transmitted and received.

Off: MIDI aftertouch messages will neither be transmitted nor received.

This setting has no effect when you use the internal sequencer to playback sequence data that was recorded with aftertouch data; i.e., aftertouch will be transmitted via MIDI.

Performing on the microSTATION’s keyboard will transmit neither channel aftertouch nor polyphonic aftertouch. However, since the microSTATION does support aftertouch as an Alternate Modulation Source (AMS), it can receive aftertouch to control.

Ctrl Chg (Enable Control Change)

[Off, On]

On: Control change messages will be transmitted and received.

Off: Control change messages will neither be transmitted nor received.

This setting has no effect when you use the internal sequencer to play back sequence data that was recorded with control change data; i.e., the control changes previously recorded into the sequencer will be transmitted via MIDI.

SysEx (Enable System Exclusive)

[Off, On]

On: System exclusive data will be transmitted and received.

Turn this On if you want parameter changes and other system exclusive data to be recorded on the internal sequencer. You should also turn this on if you’ve connected the microSTATION to your computer for data transfer or editing via the editing software.

Off: System exclusive data will not be transmitted or received.

External Setup

The assignments you make in this external setup will determine the MIDI controller and MIDI channel that is transmitted by each knob when Realtime controls EXTERNAL is selected.

In this page, you can create up to 128 different external setups. For instance, you might make one setup for controlling several different pieces of MIDI gear on stage, another for controlling a software synthesizer (such as one of Korg's Legacy Collection synths), and so on.

These External Setups are completely separate from the Program. You can think of External mode as being a separate realtime controls which just happens to share microSTATION's knobs.

When you select an External Setup, it stays selected even when you change Programs, or switch to Combination or Sequencer modes. This makes it easy to select different microSTATION sounds without disrupting any external MIDI control, and vice-versa.

After editing the setups, make sure to save your edits using the command "Write Global."

For setup examples, please see "microSTATION External Setup" (PDF).

External Setup

Here, you can create External setups.

Setup Select

[000: External Set 000...127: External Set 127]

This selects the External Setup to edit. You can assign a name to each setup.

Knob 1...4:

Channel **[Ch01...16, Glb]**

This sets the MIDI Channel for the knob. Each can send on a different channel, if desired.

Glb means that the slider will transmit on the Global MIDI Channel, as set in Global/Media mode.

CC# **[Off, 000...119]**

This sets the MIDI CC sent by the knob.

Using external setups

Note: Before you continue, you'll need to make settings so that MIDI data can be transmitted from the microSTATION to your computer application or MIDI device.

In the following explanation, we'll use the example of Program mode.

1. Press the PROG button to enter Program mode (the LED will light-up).
2. Press the EXTERNAL button to set the Realtime Controls in External mode.
3. Select the PROG EDIT: External Setup page.
4. In "Setup Select," select the external setup that you want to use.
After you've made your selection, return to PROG PLAY.
5. When you operate Realtime Control knobs 1–4, MIDI control changes (CC#) will be transmitted on the assigned MIDI channel.
The display will indicate the assignment of the knob you operated (the MIDI channel and MIDI control change) and the value that is transmitted.

Note: The microSTATION's keyboard and other controllers will operate as they normally do in each mode.

6. Switch to Combination mode.
7. Operate Realtime Controls knobs 1–4 in the same way. The settings will be maintained, allowing you to control your connected MIDI equipment.
Even if you change programs in Program mode or switch to Combination mode, that setup will remain unchanged. This means that you can select other microSTATION sounds without changing the settings that control your external MIDI device, or switch to a different external MIDI device control setup without changing sounds.
You can select external setups in the External Setup page of each mode.

Saving an external setup

 The content you edit in Global/Media mode is saved until you turn off the power, but will be lost when you turn off the power. If you want to keep your settings, you must execute "Write Global Setting" (or "Update Global Setting").

1. Press the GLB/MEDIA button to enter Global/Media mode.
2. Use the ▲▼ buttons to select MIDI, and then press the ► button.
3. Use the ▲▼ buttons to select External Setup, and press the ► button. The external setup selection page (000: External Set 000) will appear.
4. Use the ▲▼ buttons to select the external set that you want to edit, and then press the ► button. The knob selection screen will appear.
5. Use the ▲▼ buttons to select the knob that you want to edit, and then press the ► button.
6. Press the ► button to select "MIDI Channel," and use the ▲▼ buttons to specify the MIDI channel on which the knob will transmit.
7. Press the ◀ button to return, and then use the ▲▼ buttons to make the display indicate "CC#." Press the ► button to select "CC#," and specify the MIDI control change that the knob will transmit.
8. Press the ◀ button to return to the knob selection screen, and specify the MIDI channel and MIDI control change for the other knobs.

Controllers

PEDAL/SW

Type [Damper, Switch, Pedal]

This specifies the type of the switch or pedal that is connected to the DAMPER/PEDAL/SW jack.

Damper: Choose this if a half-damper pedal is connected.

Switch: Choose this if a pedal switch is connected.

Pedal: Choose this if a volume pedal is connected.

Sw (Foot Switch function)

[List of Foot Switch Assign]

This is shown if "Type" is set to Switch. Specify the function that will be controlled by the pedal switch (PS-1, sold separately) connected to the DAMPER/PEDAL/SW jack.

(☞ "List of Foot Switch assignments" on page 295)

Pdl (Foot Pedal function)

[List of Foot Pedal Assign]

This is shown if "Type" is set to Pedal. Specify the function that will be controlled by the foot volume pedal (XVP-10 or EXP-2, sold separately) connected to the DAMPER/PEDAL/SW jack.

(☞ "List of Foot Pedal assignments" on page 296)

Polarity [-KORG, +]

Set this to match the polarity of the damper pedal or pedal switch that's connected to the DAMPER/PEDAL/SW jack.

If you've connected a Korg damper pedal (separately sold DS-1H) or a Korg pedal switch (separately sold PS-1), choose the -Korg setting, since these products use a - (↓) polarity. If you've connected a damper pedal or pedal switch that uses a + (↑) polarity, choose the "+" setting (↓: open type, ↑: closed type). If this polarity setting is incorrect, using the damper pedal or pedal switch will not produce the correct result. If you have not connected a damper pedal or pedal switch, leave this set to (-).

Using a connected foot switch to select programs

You can assign a program switching function to the foot switch connected to the DAMPER/PEDAL/SW jack. This allows you to step through the program numbers one by one, either upward or downward.

If you're performing and do not want to take your hands off the keys, this provides a convenient way to quickly switch programs.

There are two ways to use a foot switch to change programs. One method is to assign the Program Up/Dwn function to the foot switch. The other method is to assign the Value Inc/Dec function to the foot switch. As described below, you can use the method that's best for your situation.

Assigning the Program Up/Dwn function to the foot switch

If you assign the Program Up/Dwn function to the foot switch, you'll be able to use the foot switch to directly control program changes, making the program increment or decrement. Normally you'll use this method.

1. Connect your foot switch to the rear panel DAMPER/PEDAL/SW jack.
Use a separately sold PS-1 pedal switch.
2. Press the GLB/MEDIA button to enter Global/Media mode.

3. Set the GLOBAL/MEDIA: Controllers - PEDAL/SW "Type" to Switch.
4. Set "Sw" to either Program Up or Program Dwn.
If you choose Program Up, the program number will increment to the next program each time you press the foot switch.
If you choose Program Dwn, the program number will decrement to the preceding program each time you press the foot switch.
5. Set "Polarity" to match the polarity of the pedal you've connected.
Choose -KORG if you've connected the separately sold PS-1 pedal switch.
Now you can press the foot switch to step through the programs.
6. If you want to keep this setting even when the power is turned off, be sure to write it (☞ "Write Global" on page 66).
7. Press the PROG button to enter PROG: PLAY, and then press the foot switch to change programs.
Note: This setting works in the same way to select combinations.

ARP RTC CC#

Here, you can assign control change messages to the arpeggiator buttons and knobs 1–4 when realtime controls C mode is selected.

When you operate a switch or knobs 1–4 when realtime controls C mode is selected, the assigned control change message will be transmitted from the MIDI OUT connector.

The assigned control change messages can also be received from an external MIDI device connected to the MIDI IN connector, and used to control the corresponding arpeggiator.

SW – ON/OFF [Off, 000...119]

Assigns a control change message sent by the ARP ON/OFF button. The default setting is CC#14.

SW – LATCH [Off, 000...119]

Assigns a control change message sent by the ARP LATCH ON/OFF button. The default setting is CC#31.

KNOB1 – GATE [Off, 000...119]

Assigns the control change message sent by knob 1 when realtime controls C mode is selected. The default setting is CC#22.

KNOB2 – VEL [Off, 000...119]

Assigns the control change message sent by knob 2 when realtime controls C mode is selected. The default setting is CC#23.

KNOB3 – SWING [Off, 000...119]

Assigns the control change message sent by knob 3 when realtime controls C mode is selected. The default setting is CC#24.

Command

Load All Demo

This command loads all demo song data that's in the microSTATION's memory.

 Before you use this command, you'll need to turn off "Memory Protect" (p.60) for the data you intend to load. If you attempt to use the command while memory protect is on, a message of "Memory Protected" will appear, and the data won't be loaded.

HalfDmpr Calib (Half Damper Calibration)

If the damper pedal connected to the DAMPER/PEDAL/SW jack does not control the half-damper effect appropriately, you can adjust the pedal calibration as follows.

 Since the operation of a half-damper pedal is delicate, please use the separately sold DS-1H. If a different pedal is used, you might not obtain the appropriate effect, or it might not be possible to make adjustments.

1. Connect your half-damper pedal to the DAMPER/PEDAL/SW jack.
2. Select the "HalfDmpr Calib" command, and then press the ► button to make the display indicate "Done?"
3. Depress the half-damper pedal, and then release it.
4. Press the ► button to apply the pedal calibration. If calibration was unsuccessful, the error message "Can't Calibrate" will appear. Try the procedure again from step 2.

Reset ARP CC#

This automatically assigns the MIDI control change messages for each controller of the Global/Media: Controllers-ARP CC# Assign.

To [All Off, CC Default]

Set the To field to the desired reset method.

All Off: All settings will be Off.

CC Default: The parameters will be reset to the typical settings, including the standard settings for the controllers.

If you want to use the controllers with an external MIDI device, we recommend using this setting.

(You are also free to assign different MIDI control change messages to the controllers, if you wish.)

The default values are shown in the table below.

Reset ARP CC# Default

Controllers	CC Default
ARP ON/OFF	CC#14
ARP LATCH	CC#31
KNOB 1 GATE	CC#22
KNOB 2 VEL	CC#23
KNOB 3 SWING	CC#24

Pedal Calib (Pedal Calibration)

This command adjusts the sensitivity of the foot pedal connected to the DAMPER/PEDAL/SW jack. The foot pedal sensitivity is adjusted to the standard setting when the microSTATION is shipped. If your foot pedal does not work appropriately, you can adjust the pedal calibration as follows.

 Please use the separately sold EXP-2 foot controller or XVP-10 expression/volume as the foot pedal. If a different pedal is used, you might not obtain the appropriate effect, or it might not be possible to make adjustments.

1. Connect your foot pedal to the ASSIGNABLE PEDAL/SW jack.
2. Select the "Pedal Calib" command, and then press the [>] button to make the display indicate "Done?"
3. Slowly advance the pedal fully away from yourself, and then return it toward yourself. (Calibration will occur correctly even if you repeat this operation more than once.)
4. Press the ► button to apply the pedal calibration. If calibration was unsuccessful, the error message "Can't Calibrate" will appear. Try the procedure again from step 2.

Note: The setting is stored in the microSTATION's memory when you perform the calibration.

Write Global

This command writes Global/Media mode settings (except for Drum Kits and Arpeggio Patterns).

 The Effect SW setting will not be saved.

Media

This mode lets you save various types of internal memory data to an SD card inserted in the microSTATION, or load data from media into internal memory. You can also delete files or format an SD card.

You can use the following media.

SD cards

MS-DOS format FAT16 or FAT32 are supported.

Recognizable capacity:FAT32: up to 2 terabytes (2,000 Gbytes)

FAT16: up to 2 Gbytes

Note: SDHC memory cards are supported.

About files and directories

The microSTATION uses files and directories on the media to manage data in a hierarchical structure.

On the microSTATION, files and directories that can be recognized by MS-DOS (i.e., that can be read by an MS-DOS computer) are called "DOS files" and "DOS directories." Different types of DOS file are distinguished by the file name extension of the DOS file.

DOS files with the following file name extension are recognized as Standard MIDI Files (SMF). However, files that are not in SMF format cannot be loaded.

Extension	Type
.PCG	Programs, combinations, drum kits, global settings, arpeggio patterns (dedicated microSTATION format)
.SNG	Songs (dedicated microSTATION format)
.MID	Standard MIDI Files (SMF format)
.EXL	MIDI exclusive data

When you format an SD card on the microSTATION, or save data for the first time, a directory named Korg/MICRO_ST will be created in the root directory. When you save data, a file below this directory will be created with an automatically-assigned name.

When saving, these file name extensions will be automatically assigned to the file according to the type of data it contains. Please note that if you use your computer to change the file name extension, the file will be considered an undefined file if you attempt to load it, and will be treated as a Standard MIDI File.

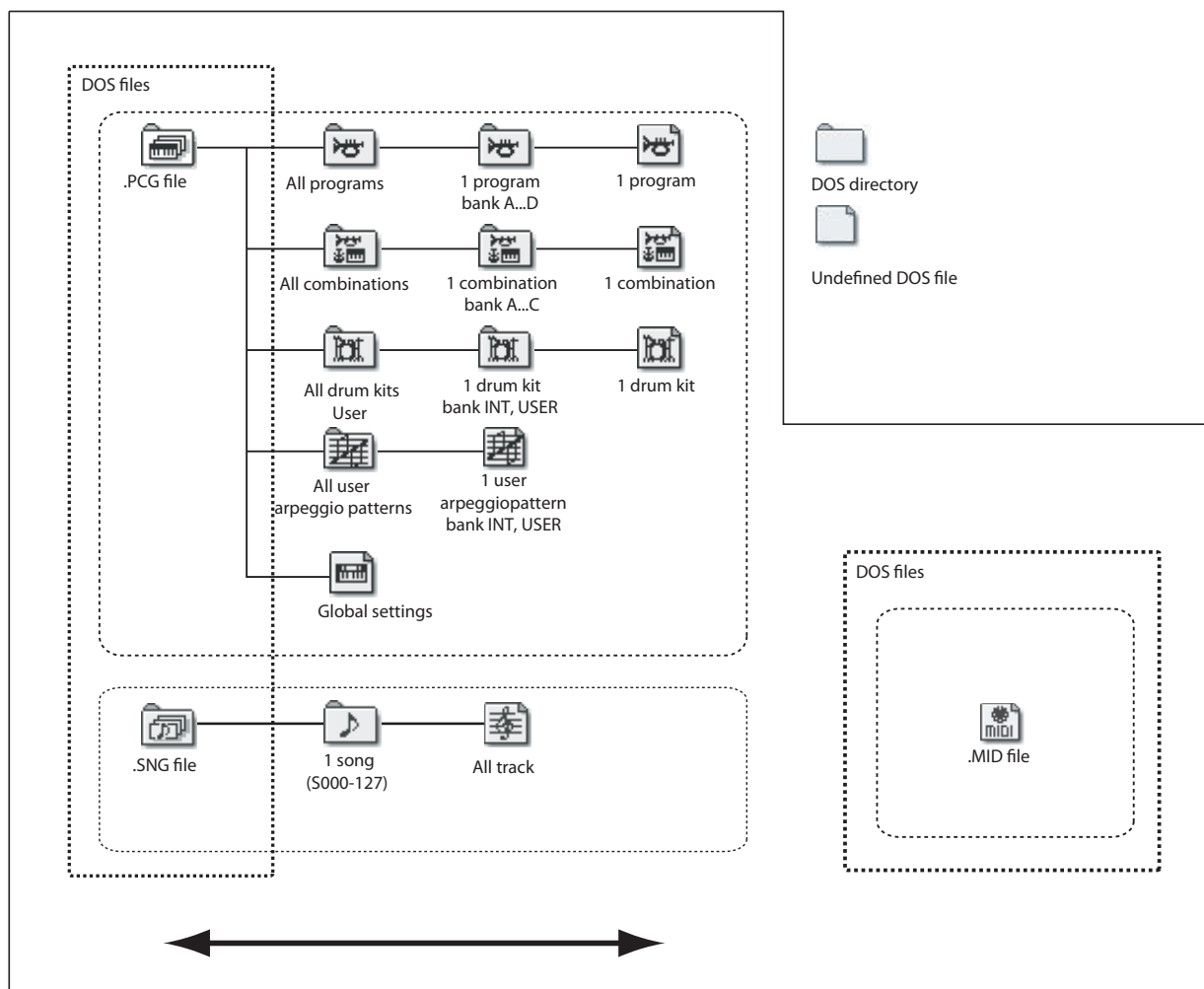

Load

These commands load the selected file or directory into internal memory.

Load PCG

Loads data from a .PCG file.

All PCG

All data in the .PCG file will be loaded.

Load All Programs

All program data in the .PCG file will be loaded.

Load All Bank A/Bank B/Bank C/Bank D

All program data in the selected bank will be loaded into the load-destination bank you specify.

To [Bank A, B, C, D]

Specify the load-destination bank.

Load a Program

Data for the selected program will be loaded into the load-destination program number you specify.

Note: The selected program can be played from the keyboard even before it's loaded; this allows you to audition the program before actually loading it.

To [A000...D127: Name]

Specify the load-destination bank and program number.

Load All Combinations

All combination data in the .PCG file will be loaded.

Load All Bank A/Bank B/Bank C

All combination data in the selected bank will be loaded into the load-destination bank you specify.

To [Bank A, B, C]

Specify the load-destination bank.

Load a Combi

Data for the selected combination will be loaded into the load-destination combination number you specify.

Note: The selected combination can be played from the keyboard even before it's loaded; this allows you to audition the combination before actually loading it.

To [A000...C127: Name]

Specify the load-destination bank and combination number.

Load All Drum Kits

All drum kit data in the .PCG file will be loaded.

Load All INT/USER

All drum kit data in the selected drum kit bank will be loaded into the load-destination drum kit bank you specify.

To [INT, USER]

Specify the load-destination bank.

 If you select drum kit bank (INT) and specify (USER) as the load-destination, drum kits 000–015 will be loaded. If you select drum kit bank (USER) and specify (INT) as the load-destination, the drum kits will be loaded into 000–015.

Load a Drum Kit

Data for the selected drum kit will be loaded into the load-destination drum kit number you specify.

Note: The selected drum kit can be played from the keyboard even before it's loaded; this allows you to audition the drum kit before actually loading it.

To [00...47: Name]

Specify the load-destination drum kit.

All Arp Patterns

All user arpeggio pattern data in the .PCG file will be loaded.

Load INT/USER

All user arpeggio pattern data of the selected user arpeggio pattern bank will be loaded into the load-destination user arpeggio pattern bank you specify.

To [INT, USER]

Specify the load-destination user arpeggio pattern bank. If you select user arpeggio pattern bank INT and specify USER as the load-destination, user arpeggio patterns 000–511 will be loaded. If you select USER and specify INT as the load-destination, the data will be loaded into user arpeggio patterns 000–511.

Load an Arp

Data for the single user arpeggio pattern you select will be loaded into the user arpeggio pattern number you specify as the load-destination.

Note: The selected user arpeggio pattern can be played from the keyboard even before it's loaded; this allows you to audition the user arpeggio pattern before actually loading it.

To [000...639]

Specify the load-destination user arpeggio pattern.

Load Global Setting

The global setting data in the .PCG file will be loaded.

This consists of the parameters other than the drum kits and user arpeggio patterns.

 The memory protect and Effect SW settings will not be loaded.

Load SNG

Data in the .SNG file will be loaded.

Load All SNG

All data in the .SNG file will be loaded.

Locate [Append, Clear]

Specify how the song data from the .SNG file will be loaded.

Append: The song will be loaded after the last song data that already exists in internal memory. At this time, the song data in the .SNG file being loaded will be packed forward. Select this when you want to add song data from media without erasing the song data that currently exists in internal memory.

Clear: All song data currently existing in internal memory will be erased, and the song data will be loaded in the state in which it was saved. Select this when you want to reproduce the saved state immediately after power-on, etc.

Load a Song

Data for the single song you select will be loaded into the load-destination song number you specify.

To [S000...S127: Name]

Specify the load-destination song.

Load SMF

The selected Standard MIDI File will be loaded into the load-destination song you specify. System exclusive messages and universal exclusive messages included in the SMF data will be loaded as exclusive events.

To [S000...S127: Name]

Specify the load-destination song.

 GS/XG sound maps and messages are not supported. Depending on the content of the data, the playback might not be correct, but the data will be preserved if "SysEx" is On.

 If you select an undefined file and start loading, the data will be loaded into the load-destination song you specify. However if the file format is invalid, an error message will appear and the operation will not be executed.

 Program banks and program numbers loaded in the song will follow the "Bank Map" settings (p.59). If "Bank Map" is Korg, bank A will be selected for bank select 00.00 (MSB.LSB). If "Bank Map" is GM (2), bank G will be selected.

Save All

All programs, combinations, drum kits, global settings, and user arpeggio patterns from internal memory will be saved to media as a .PCG file, and the song data will be saved to media as a .SNG file.

When saving, a directory named "KORG/MICRO_ST" will be automatically created in the root directory. The .PCG and .SNG files will be named automatically, and saved in the MICRO_ST folder.

You can use the "Rename" command to change the file names that are automatically assigned to each file.

 If the "Medium Full" dialog box appears, delete unneeded files to create free space on the media, and then start the save again. Alternatively, save to different media.

Save PCG

All programs, combinations, drum kits, global settings, and user arpeggio patterns from internal memory will be saved as a .PCG file to the MICRO_ST folder of the media.

Save SEQ

All songs from internal memory will be saved as a .SNG file to the MICRO_ST folder of the media.

Save To SMF (Save Song as Standard MIDI File)

Song data from internal memory will be saved as a .MID file (Standard MIDI File) to the MICRO_ST folder of the media. System exclusive events and universal exclusive events included in the song data will be saved as exclusive messages.

The song data (MIDI track data) saved by this command can be played by another device that supports Standard MIDI Files. However if you plan to play back the data on the microSTATION, you should save it using "Save SEQ," since the microSTATION's own dedicated song data format will allow a higher degree of reproducibility.

Song [S000...S127: Name]

Select the song that you want to save.

Format [0, 1]

0 (Format 0): Sixteen tracks of MIDI data will be combined into one track and saved.

1 (Format 1): Each track will be saved separately.

Rename

This command renames the selected file or directory. This is available only if a DOS file or DOS directory is selected.

Delete

This command deletes the selected file or directory. This is available only if a DOS file or DOS directory is selected.

Format

This command formats the selected media using Quick Format.

When you use the format command, a volume label (a name for each item of media) of "NEW VOLUME" will be assigned to the media, and a "MICRO_ST" folder will be automatically created in the root directory.

 Pressing the COMPARE button will not take you back to the previous state after you've used the format command.

microSTATION Full parameters



Program mode

If you connect the microSTATION to your computer, you'll be able to use the microSTATION Editor application to edit all of the microSTATION's parameters.

This chapter explains the editable parameters that are shown in the editor. For details on how to select a parameter and edit its value, refer to the "microSTATION Editor/Plug-In Editor User's Guide" included in the accessory disc.

Page structure

Panel / Page	Main content
Panel	Program selection. Tempo adjustment. (p.74) Realtime control. External Control. (p.74) Arpeggiator on/off, latch on/off. (p.74)
Quick	Oscillator play/mute, solo, and volume settings. (p.76) Edit the program quick parameters. Realtime controls knob function assignments. (p.80) Arpeggiator settings. (p.80)
Basic	Basic program settings such as voice assignment mode. (p.84) Realtime controls knob function assignments. (p.86) Arpeggiator settings. (p.87)
OSC/Pitch	Multisample selection and pitch settings. (p.91)
Filter	Filter 1 and 2 (tone) settings. (p.99)
Amp	Amp 1 and 2 (volume) settings. (p.110)
LFO	LFO settings. (p.116)
AMS MIX / Common KeyTrack	AMS mixer settings. (p.121) Common keyboard tracking settings. (p.127)
IFX	Oscillator output, and send levels to the master effects. (p.129) Insert effect routing, selection, and settings. (p.131)
MFX/TFX	Master effect routing, selection, and settings. (p.135) Total effect selection and settings. (p.136)

Panel



The microSTATION Editor's panel lets you do the following things.

- Select programs and adjust the tempo.
- Switch the realtime control mode, and use the knobs to edit in each mode.
- Use the external control knobs.
- Turn the arpeggiator on/off and arpeggiator latch on/off.

Mode Select, BROWSER, UTILITY

Mode button [PROG, COMBI, SEQ, GLOBAL]

Click a button to select the mode that you want to edit.

BROWSER button

Clicking the BROWSER button opens a program sound list. Select a program from the list and click the OK button to load the program.

Note: You can click a program in the list to select it, and then audition that program from the keyboard.

UTILITY button

The utility functions are various commands available in each page. The available utility commands will differ depending on the page. These commands also let you save or load the edited or created data on your computer, and to import system exclusive data. Click the UTILITY button and choose a command from the menu that appears.

"UTILITY Command" on page 137

Display

Program Select [A000...D127: name]

To select a program, click the ▲▼ buttons shown to the right of the program name.

Tempo [040.00...300.00]

This indicates the tempo. To set the tempo, use PROG EDIT "Tempo ♩=", or use knob 4 in Realtime Control C mode.

The arpeggiator, LFOs, and effects will synchronize to the specified tempo.

Realtime Controls

Select buttons [A, B, C]

These select the realtime control mode.

Click a button A, B, or C to switch modes.

Realtime Control Knob 1...4

These knobs control the function that is assigned for each realtime control mode.

EXTERNAL button [Off, On]

Pressing this button will switch to external control, allowing you to use the knobs to control an external MIDI device or computer application.

Arpeggiator

ARP ON/OFF button [Off, On]

This turns the arpeggiator on/off.

ARP LATCH ON/OFF button [Off, On]

This turns the arpeggiator's Latch function on/off. If this is on, the arpeggio will keep playing even after you take your hands off the keyboard while the arpeggiator is running.

Quick

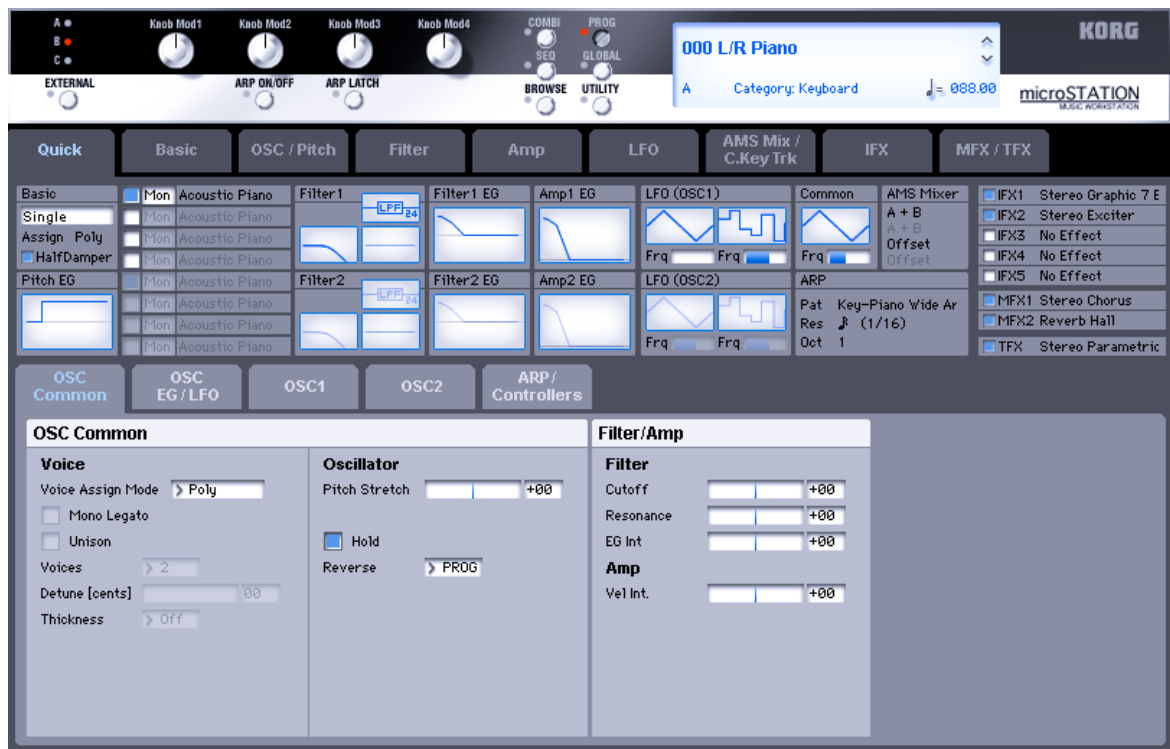

In the Quick page you'll do mainly the following thing.

- Edit the program's quick parameters.

MIDI In PROG PLAY, all MIDI data is transmitted and received on the global MIDI channel "Channel" (p.62).

Overview

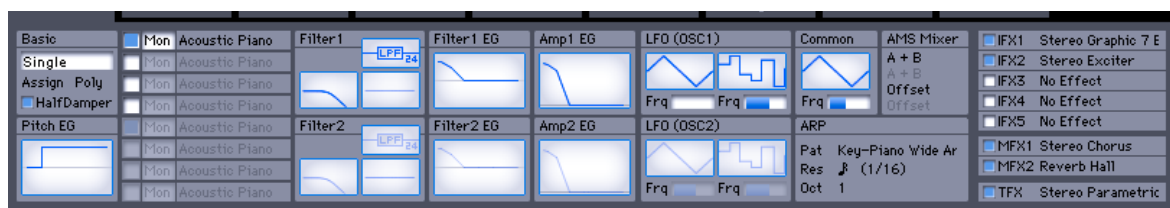

The overview shows the state of the main parameters that make up the program.

By clicking the graphic of a filter or EG, or an arpeggiator or effect setting, you can jump to the page for that parameter.

OSC Common

OSC Common

Voice

These parameters specify voice settings for oscillators 1 and 2 at the same time.

Voice Mode (Voice Assign Mode)	[Poly, Mono]
MonoLegato	[Off, On]
Unison	[On, Off]
NumOfVoices (Number of Voices)	[2...6]
Detune	[00...99 cents]
Thickness	[Off, 01...09]

See "OSC Common" on page 3.

Oscillator

These parameters adjust the transpose, hold, and reverse settings for oscillators 1 and 2 at the same time.

Transpose	[-12...0...+12 (Rel)]
Hold	[Off, On]
Reverse	[PROG, Off, On (Rel)]

See "OSC1" on page 7.

Filter/Amp

Filter

These parameters adjust the filter for oscillators 1 and 2 at the same time.

Cutoff (Filter Cutoff)	[-99...+99 (Rel, CC#74)]
Resonance (Filter Resonance)	[-99...+99 (Rel, CC#71)]
Flt EG Int (Filter EG Intensity)	[-99...+99 (Rel, CC#79)]

See "Filter/Amp" on page 5.

Amp

This parameter adjusts the amp velocity intensity for oscillators 1 and 2 at the same time.

Vel. Int (Amp Velocity Intensity)	[-99...+99 (Rel)]
--	--------------------------

See "Filter/Amp" on page 5.

OSC EG/LFO

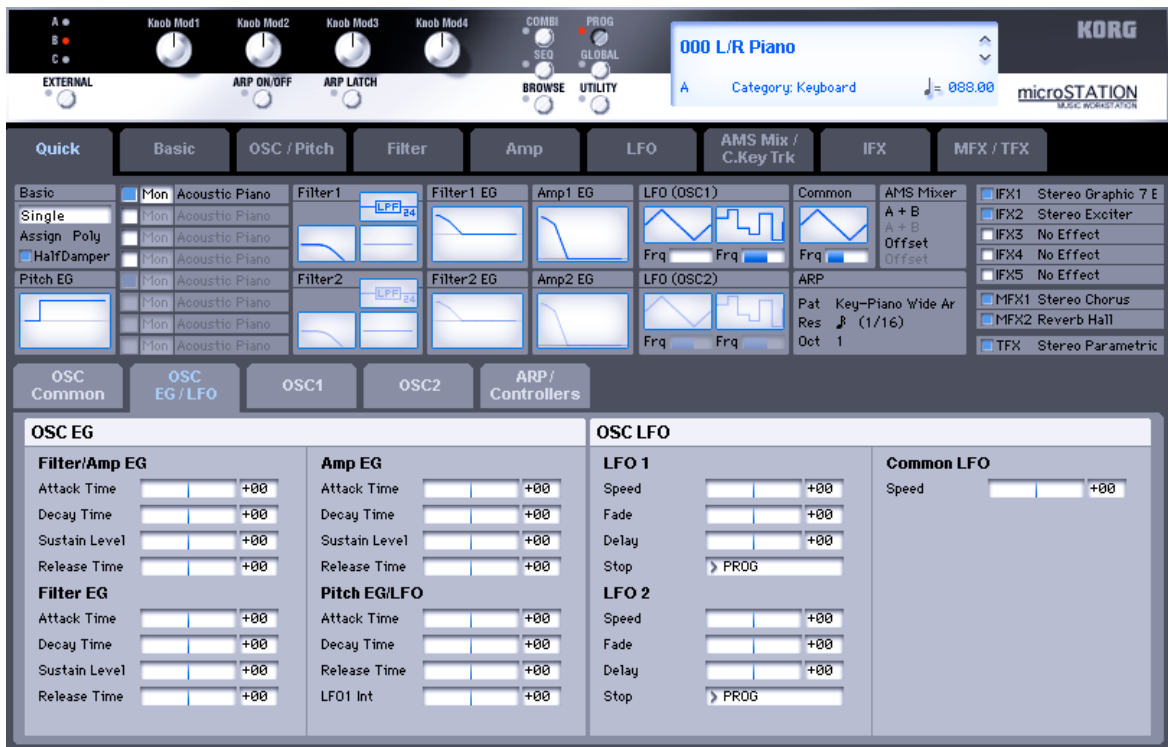

OSC EG

Filter/Amp EG

These parameters adjust the filter EG and amp EG envelopes for oscillators 1 and 2 at the same time.

Attack Time	[−99...+99 (Rel, CC#73)]
Decay Time	[−99...+99 (Rel, CC#75)]
Sustain Level	[−99...+99 (Rel, CC#70)]
Release Time	[−99...+99 (Rel, CC#72)]

See “Filter/Amp EG” on page 6.

Filter EG

These parameters adjust the filter EG envelope for oscillators 1 and 2 at the same time.

Attack Time	[−99...+99 (Rel)]
Decay Time	[−99...+99 (Rel)]
Sustain Level	[−99...+99 (Rel)]
Release Time	[−99...+99 (Rel)]

See “Filter/Amp EG” on page 6.

Amp EG

These parameters adjust the amp EG envelope for oscillators 1 and 2 at the same time.

Attack Time	[−99...+99 (Rel)]
Decay Time	[−99...+99 (Rel)]
Sustain Level	[−99...+99 (Rel)]
Release Time	[−99...+99 (Rel)]

See “Filter/Amp EG” on page 6.

Pitch EG/LFO

These parameters adjust the pitch EG envelope for oscillators 1 and 2 at the same time. You can also adjust the depth of the LFO1 effect.

Attack (Pitch EG Attack Time)	[−99...+99 (Rel)]
Decay (Pitch EG Decay Time)	[−99...+99 (Rel)]
Release (Pitch EG Release Time)	[−99...+99 (Rel)]
LFO1 Int (Pitch LFO1 Intensity)	[−99...+99 (Rel, CC#77)]

See “Pitch EG/LFO” on page 6.

OSC LFO

LFO1

These parameters adjust LFO1 for oscillators 1 and 2 at the same time.

Speed	[−99...+99 (Rel, CC#76)]
Fade	[−99...+99 (Rel)]
Delay	[−99...+99 (Rel, CC#78)]
Stop	[PROG, Off, On (Abs)]

See “LFO” on page 6.

LFO2

These parameters adjust LFO2 for oscillators 1 and 2 at the same time.

Program mode

Speed [-99...+99 (Rel)]
Fade [-99...+99 (Rel)]
Delay [-99...+99 (Rel)]
Stop [PROG, Off, On (Abs)]

See "LFO" on page 6.

Common LFO

This parameter adjusts the common LFO for oscillators 1 and 2 at the same time.

Speed [-99...+99 (Rel)]

See "LFO" on page 6.

OSC1

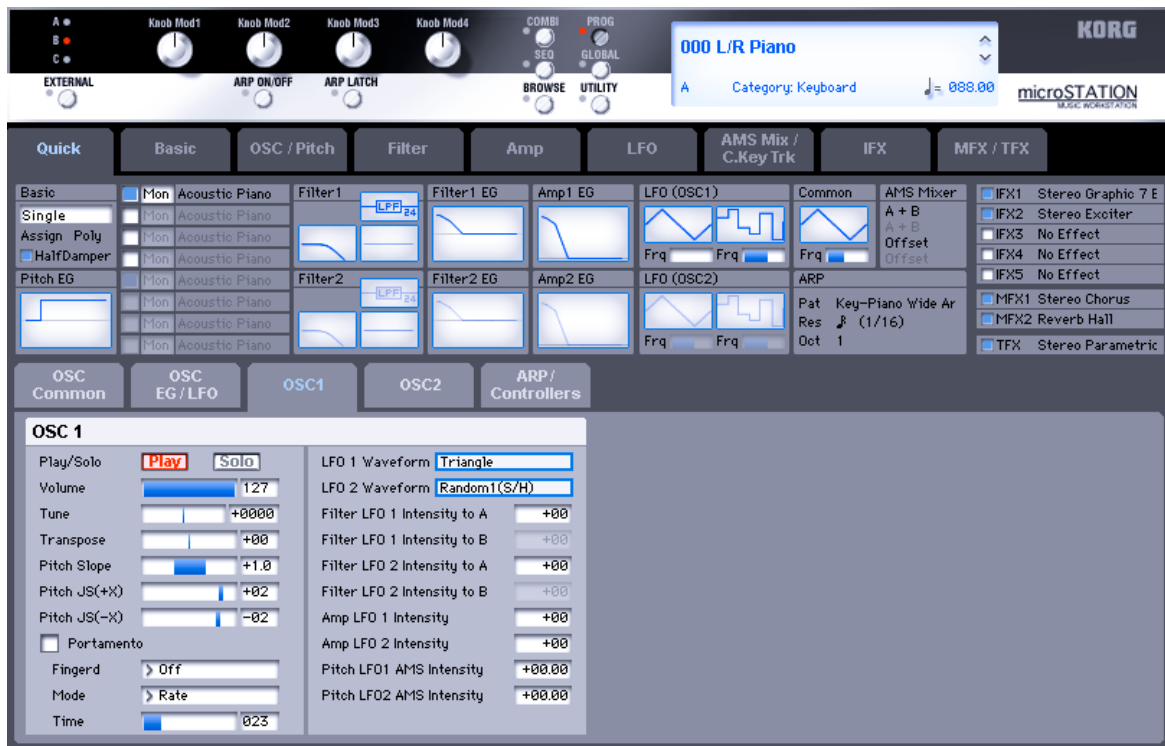

OSC1

Play/Mute [Play, Mute]

Play: Oscillator 1 will sound.

Mute: Oscillator 1 will be muted (silent).

Solo [Off, On]

Switches the Solo status on/off for oscillator 1.

Note: The Solo On/Off setting is not saved when you write the program.

Volume [000...127]

This slider adjusts the volume of Oscillator 1.

Pitch

These parameters adjust pitch-related settings for oscillator 1.

Tune [-1200...+1200]

Transpose [-60...+60]

PtchSlope (Pitch Slope) [-1.0...+2.0]

Pitch JS+X [-60...+12]

Pitch JS-X [-60...+12]

See "OSC1" on page 7.

Portamento

These parameters adjust portamento settings for oscillator 1.

Portamento [Off, On]

Fingerd [Off, On]

Mode [Rate, Time]

Time [000...127]

See "OSC1" on page 7.

LFO

These parameters adjust LFO settings for oscillator 1.

LFO1 Waveform	[Triangle...Rnd6(Cnt)]
LFO2 Waveform	[Triangle...Rnd6(Cnt)]
Filter LFO1 Intensity to A	[-99...+99]
Filter LFO1 Intensity to B	[-99...+99]
Filter LFO 2 Intensity to A	[-99...+99]
Filter LFO2 Intensity to B	[-99...+99]
Amp LFO1 Intensity	[-99...+99]
Amp LFO2 Intensity	[-99...+99]
Pitch LFO1 AMS Intensity	[-12.00...+12.00]
Pitch LFO2 AMS Intensity	[-12.00...+12.00]

See "OSC1" on page 7.

OSC2

Here you can adjust the settings for oscillator 2. These settings are available only for a program that uses two oscillators; otherwise, this page will be unavailable.

The parameters are the same as for oscillator 1.

See "OSC1" on page 7.

About Relative (Rel) and Absolute parameters

- Relative parameters have an indication of "(Rel)" following the parameter value.

The microSTATION's tone parameters are of two types: Relative and Absolute. In the case of absolute parameters, a single parameter adjusts a single program parameter. In the case of relative parameters, a single parameter simultaneously adjusts the value of two or more program parameters. For instance, "Filter/Amp EG Attack Time" affects a total of six Program parameters. The value of the Relative parameter shows the amount of change to these underlying Program parameters.

If the Relative parameter is set to 0 (the slider in the display is at the center position), the value of the corresponding program parameter will not change.

The definitions of higher and lower settings can vary, depending on the specific parameter. Unless noted otherwise, they work as follows:

When the Relative parameter is at +99 (the maximum), the Program parameters are all at their maximum as well. Similarly, when the Relative parameter is at -99 (the minimum), the Program parameters are at zero.

Relative parameter scaling

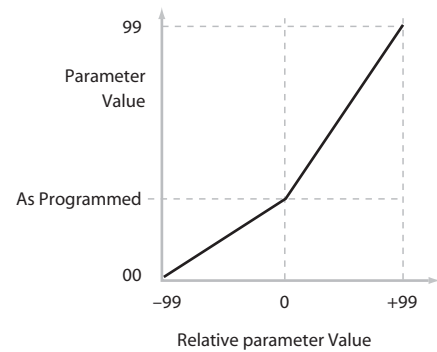

A few of the Program parameters controlled by the Relative tone parameter are bipolar, meaning that they can be either positive or negative (instead of just positive). When these Program parameters are set to negative values, the tone parameter may behave differently from the description above.

For instance, if the EG Intensity is set to a negative value, the Relative tone parameter values will range from 0 to -99, the inverse of the diagram above. EG Sustain works differently; if it's set to a negative value, tone parameter values range from 0 down to the programmed value, and then up to +99, as shown below.

Relative parameter scaling: EG Sustain

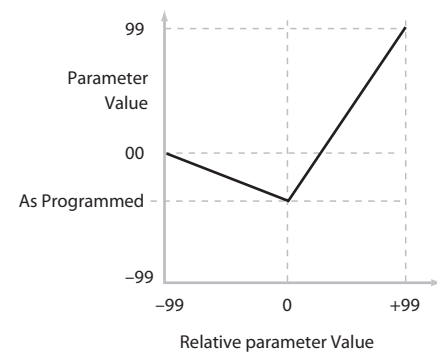

Saving parameter Edits

Parameter edits are saved in two different ways, depending on whether the parameter is Relative or Absolute.

Relative: Edits to Relative parameters affect the sound immediately, but don't change the underlying Program parameter settings until the Program is saved. When the Program is saved, the microSTATION calculates the combined effects, and saves the results into the Program parameters directly. At that point, all of the Relative parameters are reset to 0.

Absolute: Edits to Absolute parameters are immediately reflected in the corresponding on-screen parameters, and vice-versa.

Interaction between parameters and MIDI CCs

A number of the parameters can affect parameters that are also modulated by dedicated MIDI CCs. The specific CC numbers are noted in the descriptions for the individual parameters.

Parameters and the CCs work independently. It's possible, for instance, to reduce the value of a parameter, and then for a CC to increase it again.

This allows you to first edit a parameter, and then use CCs to adjust the edited result.

ARP/Controllers

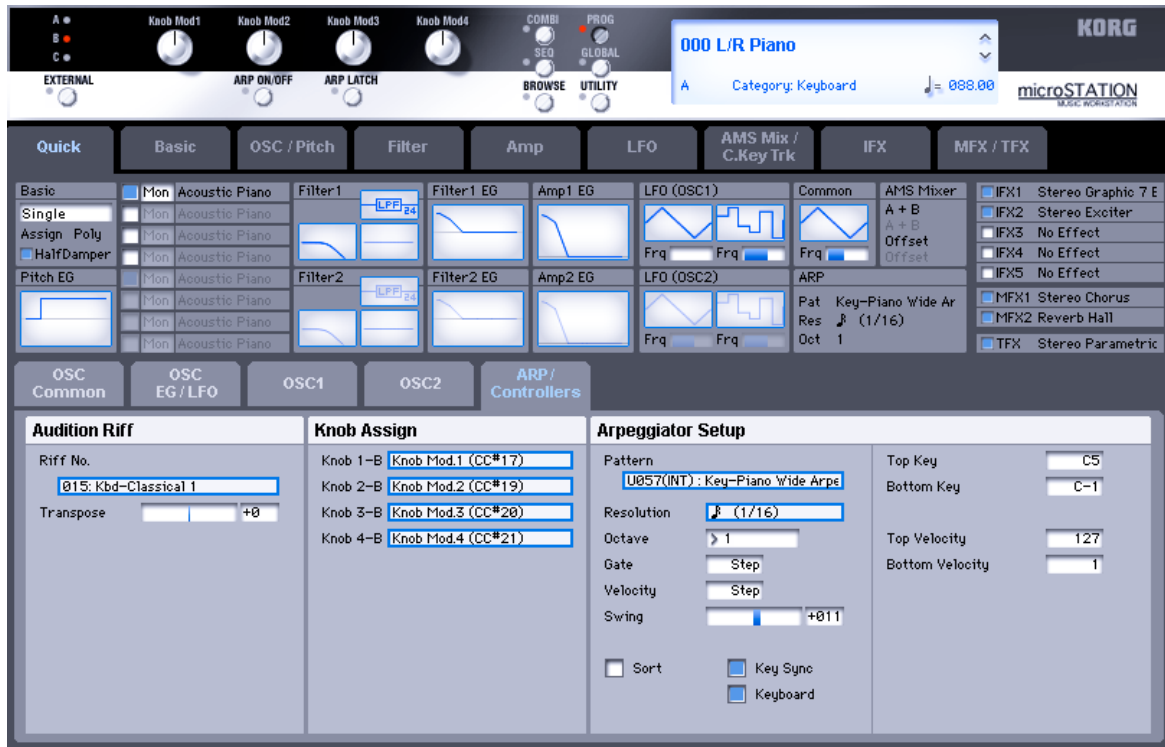

Audition

When you select a preload program, a previously specified riff (phrase) appropriate for that sound can play. This is called the Audition function.

Audition Riff [000: Off...383: name]

This selects the audition riff. The microSTATION contains 383 audition riffs that are suitable for a wide range of instrumental sounds and musical styles.

If you choose 000: Off, no riff will play.

Transpose [-24...+24]

This transposes the pitch of the audition riff in semitone steps.

You can't change the playback tempo of the audition riff. Nor can you set the arpeggiator tempo while the audition riff is playing.

The arpeggiator will be off while the audition riff is playing.

Here you can select the functions (mainly types of control change) that are assigned to knobs 1–4 when Control Assign Realtime Control B mode is selected.

Realtime Control Knob Assign

Knob1–B [Off...MIDI CC#95, CC#102...119]

Knob2–B [Off...MIDI CC#95, CC#102...119]

Knob3–B [Off...MIDI CC#95, CC#102...119]

Knob4–B [Off...MIDI CC#95, CC#102...119]

The functions you assign here are active when you use the REALTIME CONTROLS SELECT button to select B, and operate knobs 1–4.

(☞“Knob Assign (Realtime Control Knob B Assign)” on page 9)

Arpeggiator Setup

Here you can adjust arpeggiator settings for the program. The contents of the parameters are the same as in “microSTATION Quick Parameters” (☞“ARP Setup” on page 9).

Pattern [P0...P4, U000(INT)...U639(USER): name]

Selects the arpeggio pattern. (☞“Pattern” on page 9)

Resolution [♩, ♪, ♫, ♮, ♯, ♭, ♮]

Specifies the timing resolution of the arpeggio. (☞“Resolution” on page 10)

Octave [1, 2, 3, 4]

Specifies the number of octaves in which the arpeggio will be played. (☞“Octave” on page 9)

Gate [000...100(%), Step]

Specifies the length (gate time) of each note in the arpeggio. (☞“Gate[%]” on page 10)

Velocity [001...127, Key, Step]

Specifies the velocity of the notes in the arpeggio. (☞“Velocity” on page 10)

Swing [-100...+100(%)]

This parameter shifts the timing of the odd-numbered notes of the arpeggio. (☞“Swing[%]” on page 10)

Sort [Off, On]

This specifies the order in which the notes you press will be arpeggiated. (☞“Sort” on page 10)

Latch [Off, On]

Specifies whether or not the arpeggio will continue playing after you take your hand off of the keyboard. (☞“Latch” on page 10)

Key Sync. [Off, On]

Specifies whether the arpeggio pattern will begin when you press a key, or whether it will always follow the “♪ (Tempo).” (☞“KeySync” on page 10)

Keyboard [Off, On]

This specifies whether the notes you play on the keyboard will be sounded as usual in addition to being sounded as part of the arpeggio. (☞“Keyboard” on page 10)

Basic



This page contains all of the basic settings for the Program. Among other things, you can:

- Set up the Program to be a Single, a Double, or a Drum Kit
- Select the basic scale of the program.
- Enable/disable the half-damper function
- Create keyboard split settings for OSC1, OSC2, and Hold.
- Set the Program to play polyphonically or monophonically

OSC Mode

Oscillator Mode [Single, Double, Drums]

This specifies the Program's oscillator assignment; whether it will use one or two oscillators, or a drum kit.

Single: The program will use one oscillator (Oscillator 1, Filter 1, Amplifier 1). In this case, the program will normally have a maximum of 80-note polyphony.

Double: The program will use two oscillators (Oscillator 1/2, Filter 1/2, Amplifier 1/2). In this case the program will normally have a maximum of 40-note polyphony.

Drums: The program will use one oscillator (as when Single is selected), but Oscillator 1 will be assigned a drum kit instead of a multisample. In this case the program will normally have a maximum of 80-note polyphony.

Scale

Type [Equal Temperament...User Octave Scale03]

Selects the basic scale for the Program.

Note that for many of the scales, the setting of the Key parameter, below, is very important.

Equal Temperament: This is the most widely used scale by far, in which each semitone step is spaced at equal pitch intervals.

Equal Temperament allows easy modulation, so that a chord progression played in the key of C sounds roughly the same as the same progression played in F#. Sacrificed, however, is some of the purity of individual intervals offered by the scales below.

Pure Major: In this temperament, major chords of the selected key will be perfectly in tune.

Pure Minor: In this temperament, minor chords of the selected key will be perfectly in tune.

Arabic: This scale includes the quarter-tone intervals used in Arabic music.

Pythagoras: This scale is based on ancient Greek music theory, and is especially effective for playing melodies. It produces completely pure fifths, with one exception, at the expense of detuning other intervals— thirds in particular.

As much as Pythagoras might have liked to do so, it's not possible to make all the fifths pure while also keeping the octave in tune. For the sake of the octave, one of the fifths—the interval from the sharp fourth degree to the sharp first degree—is made quite flat.

Werkmeister (Werkmeister III): This scale was one of the many temperament systems developed towards the end of the Baroque period. These "Well-Tempered" tunings were aimed at allowing relatively free transposition—although

you'll still notice that the different keys maintain their own distinct characteristics, unlike Equal Temperament.

J.S. Bach was referring to these new scales in his title, "The Well-Tempered Clavier." As such, this group are particularly appropriate for late baroque organ and harpsichord music.

Kimberger (Kimberger III): This is a second "Well-Tempered" tuning, dating from the early 18th century.

Slendro: This is an Indonesian gamelan scale, with five notes per octave.

When Key is set to C, use the C, D, F, G and A notes. Other keys will play the normal equal-tempered pitches.

Pelog: This is another Indonesian gamelan scale, with seven notes per octave.

When Key is set to C, use the white keys. The black keys will play the equal tempered pitches.

Stretch: This tuning is used for acoustic pianos.

User All Notes Scale: This is a user-programmed scale with different settings for all 128 MIDI notes. You can set up this scale in Global mode (p.186).

User Octave Scale 00-03: These are user-programmed scales with settings for each of the 12 notes in an octave. You can set them up in Global mode (p.186).

Key (Scale Key) [C...B]

Selects the key of the specified scale.

This setting does not apply to the Equal Temperament, Stretch, and User All Notes scales.

 If you're using a scale other than Equal Temperament, the combination of the selected scale and the Key setting may skew the tuning of the note. For example, A above middle C might become 442 Hz, instead of the normal 440 Hz. You can use the Global Mode's Master Tune (p.182) parameter to correct this, if necessary.

Random [0...7]

This parameter creates random variations in pitch for each note. At the default value of 0, pitch will be completely stable; higher values create more randomization.

This parameter is handy for simulating instruments that have natural pitch instabilities, such as analog synths, tape-mechanism organs or acoustic instruments.

Half-Damper Control

A half-damper pedal is a special type of continuous foot pedal, such as the Korg DS-1H. In comparison to a standard foot switch, half-damper pedals offer more subtle control of sustain, which can be especially useful for piano sounds.

The microSTATION will automatically sense when a half-damper is connected to the rear-panel DAMPER/PEDAL/SW input. For proper operation, you will also need to calibrate the pedal, using the Half Damper Calibration command in the Global command. (p."HalfDmpr Calib (Half Damper Calibration)" on page 66)

The off and full-on positions of the half-damper work just like a standard foot switch. In conjunction with the Enable Half-Damper parameter, below, intermediate positions allow a graduated control of sustain, similar to the damper pedal of an acoustic piano.

Enable Half-Damper [On, Off]

On: Half-Damper pedals, normal sustain pedals, and MIDI CC# 64 will all modulate the Amp EG, as described below.

Off: the pedals and MIDI CC#64 will still hold notes as usual, but will not modulate the Amp EG.

Half-Damper Pedal and Release Time

The amount of modulation depends on whether the Amp EG Sustain Level is set to 0 (as is the case with most acoustic piano sounds), or set to 1 or more. The modulation is continuous, from 1x (no change) to 55 times longer; the table below shows a selection of representative points.

Half-Damper modulation of Amp EG Release Time

CC#64 Value	Multiply Amp EG Release Time by...	
	If Sustain = 0	If Sustain = 1 or more
0	1x	1x
32	2.1x	2.1x
64	3.2x	3.2x
80	5.9x	
96	22.3x	
127	55x	

Key Zone

You can create keyboard splits by setting top and bottom key limits for Oscillators 1 and 2. Also, you can control the keyboard range over which the "Hold" parameter takes effect.

OSC1

Bottom Key [C-1...G9]

This sets the lowest key where Oscillator 1 will play.

Top Key [C-1...G9]

This sets the highest key where Oscillator 1 will play.

OSC2

Bottom Key [C-1...G9]

This sets the lowest key where Oscillator 2 will play.

Top Key [C-1...G9]

This sets the highest key where Oscillator 2 will play.

Hold

Hold [On, Off]

Hold is like permanently pressing down on the sustain pedal. In other words, notes continue to sound as if you were holding down the key - even after you lift your fingers from the keyboard.

Unless the Sustain Level is set to 0 in Amp EG 1 (and Amp EG 2 in a Double Program), the sound will play for the entire length of the multisample(s).

On: The Hold function is enabled for the range set by the Hold Bottom and Hold Top parameters, below.

Off: Notes will play normally. This is the default setting.

Hold Bottom Key [C-1...G9]

This sets the lowest key affected by the Hold function.

Hold Top Key [C-1...G9]

This sets the highest key affected by the Hold function.

Using Hold with Drum Kits

Hold can be especially useful for drum programs, since it lets the drum samples ring out naturally. In general, when you set the Oscillator Mode to Drums, it's good to set Hold to On.

Once you've turned on Hold for a drum program, the function is controlled on a note-by-note basis according to settings within the selected Drum Kit.

If a key's "Enable Note Off Recv" parameter (p.191) is unchecked, the note will be held.

If the key's "Enable Note Off Recv" parameter is checked, it will not be held.

If you turn off Hold in the Program, no keys will be held - regardless of their "Enable Note Off Recv" setting.

Using Hold with Acoustic Pianos

Hold is also useful for simulating the top octaves of an acoustic piano, in which notes always sustain until they fade out naturally, regardless of how long you hold the key.

The "Hold Bottom Key" and "Hold Top Key" parameters are designed for exactly this purpose. They let you limit the effect of the Hold parameter to a specific range of the keyboard.

Program Basic

Voice Assign Mode

Mode (Voice Assign Mode) [Poly, Mono]

Select the basic voice allocation mode. Depending on which one you select, various other options will appear, such as Poly Legato (Poly mode only) and "Unison" (Mono mode only).

Poly: The program will play polyphonically, allowing you play chords.

Mono: The program will play monophonically, producing only one note at a time.

Poly

Poly Legato [Off, On]

Poly Legato is available when the Voice Assign Mode is set to Poly.

Legato means playing notes so that they are smooth and connected; the next note is played before the last note is released. This is the opposite of playing detached.

On: When you play a legato phrase, only the first note of that phrase (and within approximately the first 30msec) will use the normal multisample start point specified by "Start Offset" (p.89); all subsequent notes will use the legato start point specified for each multisample.

This is a useful way to simulate the percussive attack of a tonewheel-type organ.

Off: Notes will always use the setting of the "Start Offset," regardless of whether you play legato or detached.

 With some Multisamples, Poly Legato may not have any effect.

Single Trigger [Off, On]

Single Trigger is available when the Voice Assign Mode is set to Poly.

On: When you play the same note repeatedly, the previous note will be silenced before the next note is sounded, so that the two do not overlap.

Off: When you play the same note repeatedly, the notes will overlap.

Mono

Mono Legato [Off, On]

This is available when the "Voice Mode" is set to Mono.

Legato refer to notes that are played in a way that they sound smooth and connected; the next note is played before the last note is released. This is the opposite of playing detached.

On: When you play with legato phrasing, the notes within a legato phrase will sound smoother.

When "Mono Legato" is **On**, the first note in a legato phrase will sound normally, and then subsequent notes will have a smoother sound, for more gentle transitions between the notes.

Off: Legato phrasing will produce the same sound as detached playing.

Mono Mode [Normal, Use Legato Offset]

This parameter is available only when Mono Legato is On.

Normal: When you play legato, the multisample, envelopes, and LFOs will not be reset; only the pitch of the oscillator will change. This setting is particularly effective for wind instruments and analog synth sounds.

 With this option, the pitch may occasionally be incorrect, depending on which multisample you play, and where on the keyboard you play.

Use Legato Offset: When you play legato, the second and subsequent notes will use the legato start point specified for each multisample, rather than the "Start Offset" (p.89) setting.

This is effective when used with a multisample for which you've assigned a specific legato offset point. For example, you might use it to control the attack of a breathy, slow-attack sax sound. On some multisamples, this will have no effect.

Envelopes and LFOs will still be reset, as they are with detached playing.

Priority [Low, High, Last]

Priority is available when the Voice Assign Mode is set to Mono.

This parameter determines what happens when more than one note is being held down.

Low: The lowest note will sound. Many vintage, monophonic analog synths work this way

High: The highest note will sound.

Last: The most recently played note will sound.

Unison [On, Off]

Unison can be used in Mono mode.

On: When Unison is on, the Program uses two or more stacked, detuned voices to create a thick sound.

Use the "Voices" and "Detune" parameters to set the number of voices and amount of detuning, and the "Thickness" parameter to control the character of the detuning.

Off: The Program plays normally.

Voices (Number of Voices) [2...6]

This controls the number of detuned voices that will be played for each note when using "Unison." It applies only when Unison is On.

Detune [cents] [00...99 cents]

Detune is available when Unison is On.

This parameter sets the tuning spread for the Unison voices, in cents (1/100 of a semitone). The "Thicknes" parameter, below, controls how the voices are distributed across the detune amount. When "Thickness" is Off, the voices are distributed evenly, centered around the basic pitch.

For instance, let's say that the "Voices" parameter is set to 3, "Detune" is set to 24, and "Thicknes" is Off:

Voice one will be detuned down by 12 cents, voice two will not be detuned, and voice three will be detuned up by 12 cents.

Voice	Detune
1	-12
2	0
3	+12

As another example, let's say that Detune is still set to 24 and Thickness is still Off, but the Number of voices is set to 4:

Voice one will still be detuned down by 12 cents, voice two will be detuned down by 4 cents, voice three will be detuned up by 4 cents, and voice 4 will be detuned up by 12 cents.

Voice	Detune
1	-12
2	-4
3	+4
4	+12

Thickness [Off, 1...9]

Thickness is available when Unison is On.

This parameter controls the character of the detuning function for the unison voices.

Off: Unison voices will be evenly distributed across the Detune range, as shown above.

1-9: Unison voices will be detuned in an asymmetrical way, increasing the complexity of the detune fuction, and changing the way that the different pitches beat against one another. This creates an effect similar to vintage analog synthesizers, where oscillators would frequently drift slightly out of tune. Higher numbers increase the effect.

Controllers



Here you can select the functions (mainly types of control change) that are assigned to knobs 1–4 when Control Assign Realtime Control B mode is selected.

Realtime Control Knob Assign

- Knob1–B** [Off...MIDI CC#95, CC#102...119]
- Knob2–B** [Off...MIDI CC#95, CC#102...119]
- Knob3–B** [Off...MIDI CC#95, CC#102...119]
- Knob4–B** [Off...MIDI CC#95, CC#102...119]

The functions you assign here are active when you use the REALTIME CONTROLS SELECT button to select B, and operate knobs 1–4.

(☞ “Knob Assign (Realtime Control Knob B Assign)” on page 9)

ARP

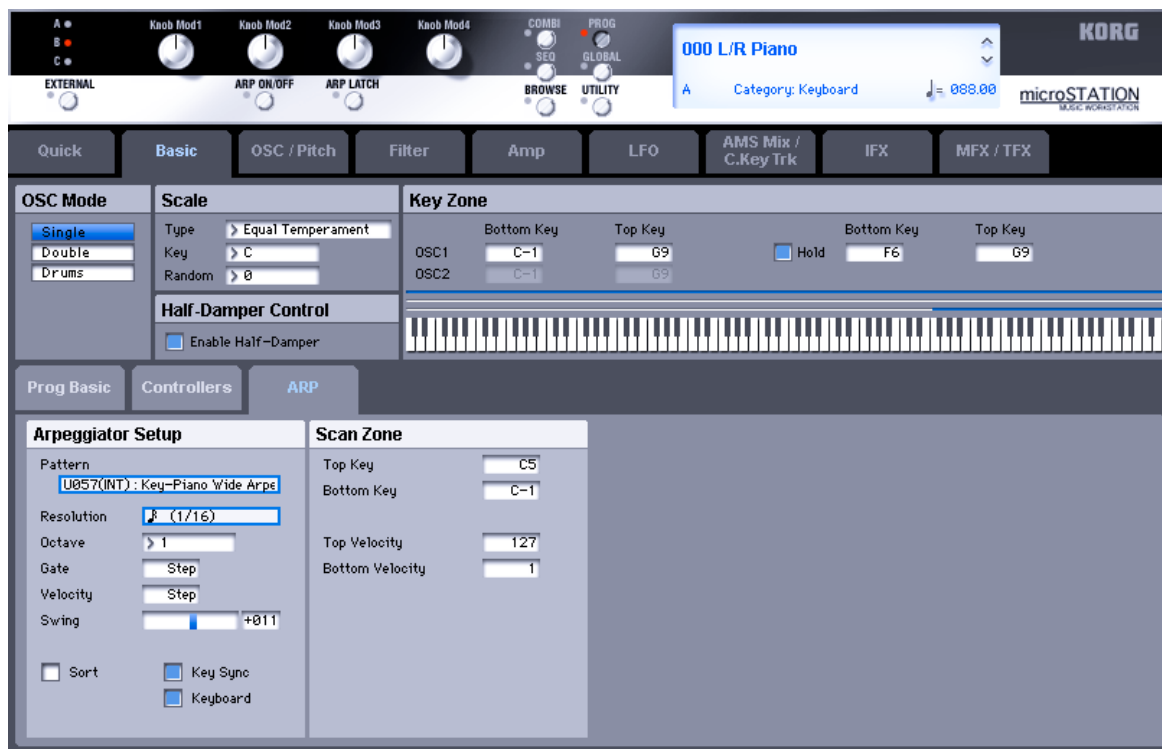

Here you can adjust settings for the arpeggiator used by the program.

The parameters are the same as “microSTATION quick parameters – Arp Setup”. (☞“ARP Setup” on page 9)

Arpeggiator Setup

Pattern [P0...P4, U000(INT)...U639 (USER): name]

Selects the arpeggio pattern.

(☞“Pattern” on page 9)

Resolution [1/16, 1/8, 1/4, 1/2, 1, 2, 4, 8, 16]

Specifies the timing resolution of the arpeggio. (☞“Resolution” on page 10)

Octave [1, 2, 3, 4]

Specifies the number of octaves in which the arpeggio will be played. (☞“Octave” on page 9)

Gate [000...100(%), Step]

Specifies the length (gate time) of each note in the arpeggio. (☞“Gate[%]” on page 10)

Velocity [001...127, Key, Step]

Specifies the velocity of the notes in the arpeggio. (☞“Velocity” on page 10)

Swing [-100...+100(%)]

This parameter shifts the timing of the odd-numbered notes of the arpeggio. (☞“Swing[%]” on page 10)

Sort [Off, On]

This specifies the order in which the notes you press will be arpeggiated. (☞“Sort” on page 10)

Latch [Off, On]

Specifies whether or not the arpeggio will continue playing after you take your hand off of the keyboard.

(☞“Latch” on page 10)

Key Sync. [Off, On]

Specifies whether the arpeggio pattern will begin when you press a key, or whether it will always follow the “♪ (Tempo).” (☞“KeySync” on page 10)

Keyboard [Off, On]

This specifies whether the notes you play on the keyboard will be sounded as usual in addition to being sounded as part of the arpeggio. (☞“Keyboard” on page 10)

Scan Zone

Top Key [C-1...G9]

Bottom Key [C-1...G9]

These parameters specify the range of notes (keys) for which the arpeggiator will function. (☞“Top Key” on page 10), (☞“BottomKey” on page 10)

Top Velocity [001...127]

Bottom Velocity [001...127]

These parameters specify the range of velocities for which the arpeggiator will function. (☞“Top Vel” on page 10), (☞“Bottom Vel” on page 10)

OSC/Pitch



These pages control the first and most basic elements of sounds: the Multisamples that the oscillators play, and the pitch used to them. For instance, you can:

- Select Multisamples for Single and Double Programs, or Drum Kits for Drum Programs.
- Set up velocity splits, crossfades, and layers for Single and Double Programs.
- Set the basic pitch of the sound, including the octave, fine tuning, and so on.
- Control pitch modulation using a variety of controllers such as LFO, pitch EG, and the joystick.

Note that when the Oscillator Mode is set to Single or Drums, only Oscillator 1's filters are active; the pages for Oscillator 2's filters will be grayed out.

OSC1

This setting will depend on the Oscillator Mode setting. If it is Single or Double, each oscillator can use up to four multisamples. In Drum mode, there is one Oscillator, and it plays a single Drum Kit.

Multisamples, and Drum Kits

Multisamples and Drum Kits allow you to play samples in different ways.

- Multisamples lay out one or more samples across the keyboard. For instance, a very simple guitar Multisample might have six samples—one for each string.
- As the name suggests, Drum Kits are optimized for playing drum samples.

Velocity splits, crossfades, and layers

As mentioned above, unless you're in Drum mode, each Oscillator has four velocity zones, named High through Low. Each of these zones can play a Multisample, and has each separate settings for "Level," "Start Offset," and so on.

Each of the zones can fade into the next, to create smoother velocity transitions. Zones can even be layered together, two at a time.

You can stack a maximum of two velocity zones, causing two samples to sound simultaneously (layering). You can also use velocity to smoothly fade between the samples of these two zones (velocity crossfading).

"Oscillator Mode" Single, Double

High:

These are the settings for the first and highest velocity zone. If you want to create a simple setup with only a single Multisample, just set up High as desired, and then set the "Bottom Vel." (Bottom Velocity) to 1 and the "Range" to Off.

Multisample On/Off

[Off, On]

This specifies whether the High multisample will sound. It will sound if this is On.

Bank

[Mono, Stereo]

This is displayed if Multisample On/Off is On.

You can choose between looking at mono and stereo Multisamples. Note that stereo Multisamples will require twice as many voices as mono Multisamples.

Mono: Internal monaural multisamples.

Stereo: Internal stereo multisamples.

Multisample select [List of Multisample]

This specifies a multisample for High.

 Some multisamples have an upper limit; notes played above that limit will not sound.

Mid Hi, Mid Lo, Low

These are the settings for the second, third, and fourth velocity zones. The parameters for Mid Hi and Mid Lo are exactly the same as those for High, as described above.

The parameters for Low are also similar to those for High, except that Low has no settings for “Bottom Vel.” (which is always fixed at 1), Xfd, or Curve.

“Oscillator Mode” Drums**What is a drum kit?**

Drum kits can be created or edited only by using the included microSTATION Editor; they cannot be edited from the microSTATION itself.

Drum kits are created or edited in Global mode. To each note of the keyboard, you can assign up to four drum instrument samples, and use layering, crossfading, or velocity switching to switch between them. Then, in Program mode, you can make filter and amp settings, and specify effects and routing to the audio output jacks.

For details, please see “Creating a Drum Kit” on page 192.

To use a drum kit in a Program, set “Oscillator Mode” to Drums, and choose one of the 144 user drum kits or the nine GM2 drum kits.

High (DKit):

These parameters appear when the “Oscillator Mode” is set to Drums.

Multisample (DrumKit)

[000...031 (INT), 032...047 (USER), 048...056 (GM)]

This selects a drum kit.

Note: For 000(INT)–047(USER), you can use Global: Drum Kit to edit the instrument assignments.

OSC2

Here you can select the multisample for Oscillator 2.

It is only available when the Oscillator Mode is set to Double; if it's not, the page will be grayed out.

The parameters are identical to those for Oscillator 1. (☞ “OSC1” on page 88)

PITCH EG

This displays the pitch EG envelope specified in the Pitch EG page.

OSC1 Multisample

Program's sounds are based on multisamples, and this page lets you set up all of the basic multisample-related settings. Among other things, you can:

- Select Multisamples for the Oscillator (in a Single or Double Program), or select the Drum Kit for a Drum Program
- Set the Oscillator's basic pitch
- Create velocity splits and crossfades between Multisamples

What is a multisample?

A sample is a digital recording of a particular instrument or waveform (or other natural or artificially processed sound) recorded at a specific pitch. A multisample is a collection of similarly voiced samples, used to create the same type of sound - piano, bass, guitar, strings, organ - across the entire keyboard, as the basis of a program. The oscillators of single and double programs use multisamples. There are 360 multisamples available in this instrument.

You can assign up to four multisamples to each oscillator and switch between them by velocity.

High**Start Offset**

[Off, 1st...8th]

In addition to simply starting playback from the beginning, Multisamples can have up to 8 different pre-programmed alternate starting points.

The Start Offset specifies whether to use the normal start point (Off), or to use one of the alternate start points (1st–8th).

Some Multisamples may have fewer than 8 pre-programmed points, in which case only the available points can be selected.

Offset Level

[0...127]

This sets the basic volume level of the multisample. The Amp section can modify this basic level extensively with envelopes, LFOs, keyboard tracking, and other modulation; for more information, please see “Amp” on page 110.

 Depending on the multisample, high Level settings may cause distortion when playing many notes at a time. If this occurs, lower the Level.

Reverse

[Off, On]

This plays the selected multisample in reverse without looping it.

If an individual sample within the multisample is already set to reverse, it will play in reverse without this setting.

On: The multisample will play in reverse.

Off: The multisample will play normally.

Crossfade

Bottom Vel (Bottom Velocity) [1...127]

This sets the lowest velocity where the Multisample will sound. High's "Bottom Vel." can be equal to, but not lower than, that of Mid Hi.

Range (Crossfade Range) [Off, 1...127]

This sets the range of velocities over which High will fade into Mid Hi, going up from the "Bottom Vel."

For instance, if the "Bottom Vel." is set to 64, and the "Range" is set to 20, Mid Hi will start to fade in at velocities of 84 and below.

When velocities are within the "Range," the Oscillator will use twice as much polyphony as it would normally.

Note: You can only fade between two zones at once.

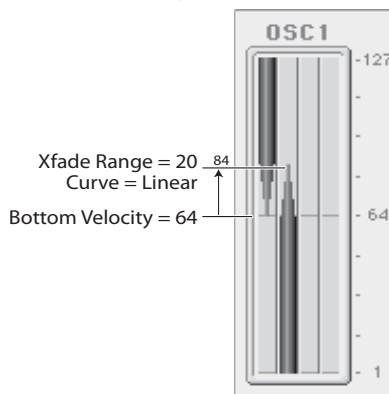

Curve [Linear, Power, Layer]

This controls the volume curve of the crossfade. Linear and Power (short for Equal Power) let you fine-tune the way that the two Multisamples mix together; one or the other may be more appropriate for a given pair of Multisamples. Layer, true to its name, lets you layer the two Multisamples together without any crossfading.

Linear means that the two samples will each be at 50% of their full volume in the middle of the crossfade. Sometimes, this may create a dip in the volume level; if so, try using Power instead.

Power, short for Equal Power, means that the two samples will each be at around 70% of their full volume in the middle of the crossfade. Sometimes, this may create a bump in the volume level, in which case you might try selecting Linear instead.

Layer means that the two Multisamples will be layered together, both at full volume, for the entire range of the crossfade.

Crossfade Curves

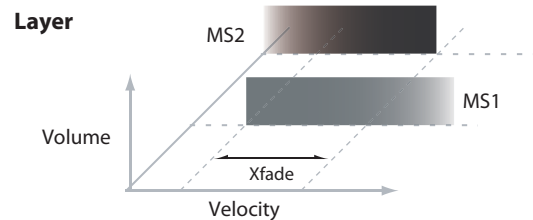
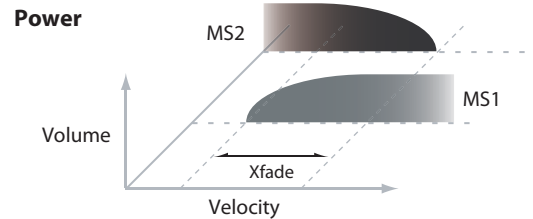
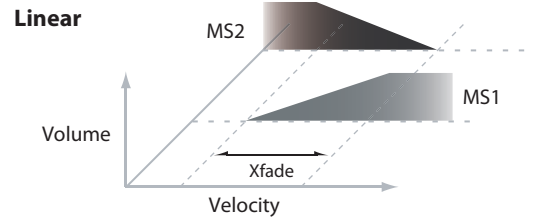

Mid High, Mid Lo, Low

These are the settings for the second, third, and fourth velocity zones. The parameters for Mid Hi and Mid Lo are exactly the same as those for High, as described above. The parameters for Low are also similar to those for High, except that Low has no settings for "Bottom Vel." (which is always fixed at 1), "Range," or "Curve."

OSC1 Pitch

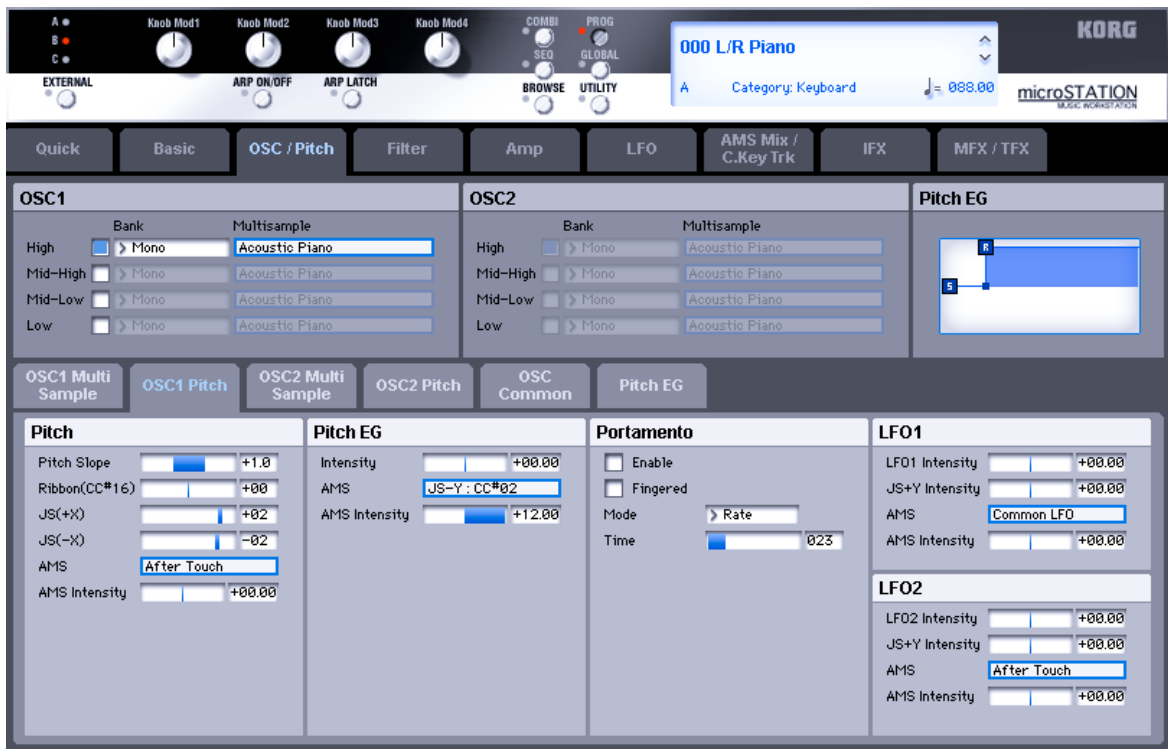

This page contains all of the settings for Oscillator 1’s pitch modulation. For example, you can:

- Specify pitch bend controlled by the joystick X (or an incoming pitch bend message) set to independent Bend Up and Bend Down, or controlled by an incoming message CC#16 (the ribbon control message etc).
- Use Pitch Slope to control how the pitch changes when you play up and down the keyboard.
- Assign AMS modulation for pitch.
- Set up initial amounts of pitch modulation from the Pitch EG and LFO1/2, as well as AMS modulation of LFO and EG amounts.
- Set up Portamento.

Alternate Modulation

Alternate Modulation lets you use controllers, envelopes, LFOs, etc. to modulate Program parameters. You can use one controller to modulate multiple parameters simultaneously. You can also create complex modulation setups in which (for example) an envelope modulates the frequency of an LFO, and that LFO is then used to modulate a filter. Programs provide 48 types (88 destinations) for alternate modulation.

AMS (Alternate Modulation Source)

AMS (Alternate Modulation Source) refers to any of the assignable modulation sources in the microSTATION, including:

- Controllers of the microSTATION itself, such as the joystick and the realtime knobs
- Incoming MIDI controllers
- Modulators such as the Filter, Pitch, and Amp EGs, the LFOs, or the AMS Mixers

Intensity is a parameter that’s used to set the degree (speed, depth, amount etc.) of how AMS will control the modulation.

A number of frequently-used modulation routings, such as using the joystick to vary the pitch, are provided as additional, dedicated routings, separate from AMS.

Note that not all AMS sources may be available for some modulation destinations.

For details on alternate modulation and AMS, please see “Alternate Modulation Source (AMS)” on page 287.

Tips for using AMS

When adjusting settings for alternate modulation, think of the effect that you wish to produce, what type of modulation will be necessary to produce that effect, and what parameter of the oscillator, filter, or amplifier needs to be controlled.

Next, select a source (AMS) and set the Intensity. If you proceed logically in this way, you will achieve the desired effect.

For example in a guitar sound program where you want to use the joystick to control the feedback, you would make assignments so that the joystick controls the filter frequency and resonance.

Pitch

Pitch Slope [-1.0...+2.0]

Normally, this should be set to the default of +1.0.

Pitch Slope, pitch, and note

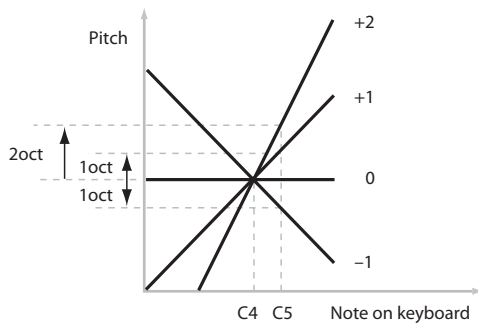

Positive (+) values cause the pitch to rise as you play higher on the keyboard, and negative (-) values cause the pitch to fall as you play higher on the keyboard.

When this is set to 0, playing different notes on the keyboard won't change the pitch at all; it will be as if you're always playing C4. This can be useful for special effects sounds, for instance.

Ribbon (CC#16) [-12...+12]

This specifies in semitones how the pitch will change when CC#16 is received.

With a positive (+) setting, the pitch will rise when the value of CC#16 is higher than the center value of 64. With a negative (-) setting, the pitch will fall.

JS (+X) [-60...+12]

Specify in semitones how the pitch will change when the joystick is moved to the right (or when a pitch bend message is received). For normal pitch bend, set this to a positive value.

For example, if you set this to +12 and move the joystick all the way to the right, the pitch will rise one octave above the original pitch.

JS (-X) [-60...+12]

Specify in semitones how the pitch will change when the joystick is moved to the left (or when a pitch bend message is received). For normal pitch bend, set this to a negative value.

For example, if you set this to -60 and move the joystick all the way to the left, the pitch will fall five octaves below the original pitch. You can use this to create guitar-style downward swoops.

AMS (Pitch) [List of AMS Sources]

This selects an AMS source to control the pitch.

For a list of AMS sources, "AMS (Alternate Modulation Source) List" on page 287.

AMS Intensity [-12.00...+12.00]

This controls the depth and direction of the pitch modulation, in semitones.

For example if you set AMS (Pitch) to JS+Y: CC#01 and then move the joystick in the +Y direction, the pitch will rise if this parameter is set to a positive (+) value, or fall if this parameter is set to a negative (-) value.

Pitch EG

Intensity [-12.00...+12.00]

This controls the initial effect of the Pitch EG on Oscillator 1's frequency, in half-steps, before any AMS modulation.

The Pitch EG's shape can swing all the way from +99 to -99. When the Intensity is set to a positive (+) value, positive values from the EG raise the pitch, and negative values lower the pitch.

When the Intensity is set to a negative (-) value, the effect of the EG is reversed; positive EG values mean lower pitches, and negative EG values mean higher pitches.

AMS (Pitch EG) [List of AMS Sources]

This selects any AMS modulation source to scale the amount of the Pitch EG.

For a list of AMS sources, "AMS (Alternate Modulation Source) List" on page 287.

AMS Intensity [-12.00...+12.00]

This controls the depth and direction of the pitch EG AMS modulation. The AMS modulation and the initial Intensity are added together to determine the Pitch EG's final effect.

With positive (+) values, greater modulation will increase the effect of the Pitch EG, as shown in example B below.

With negative (-) values, greater modulation will introduce the opposite effect of the Pitch EG—like inverting the polarity of the envelope. You can use this in several different ways:

- You can set an initial positive amount with the Intensity parameter, and then reduce this amount with AMS. In this case, the final effect of the EG is simply diminished, and not actually inverted, as shown in example C.
- You can also set the AMS Intensity amount to be greater than the initial Intensity. In this case, the EG will have a positive effect with low modulation amounts, and an inverted effect at higher modulation amounts—as shown in example D.

Pitch EG AMS

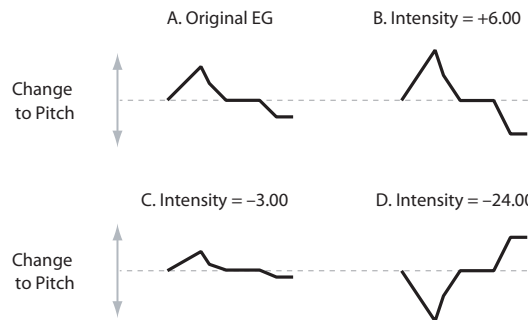

Portamento

Portamento lets the pitch glide smoothly between notes, instead of changing abruptly.

Enable [Off, On]

(☞ "Portamento (Portamento Enable)" on page 7)

Fingered [Off, On]

(☞ "PortaFinger (Portamento Fingered)" on page 7)

Mode [Rate, Time]

(☞ "PortaMode (Portamento Mode)" on page 7)

Time [000...127]

(☞ "PortaTime (Portamento Time)" on page 7)

LFO1

LFO1 and LFO2 can both control the pitch. You can control the strength of each LFO's modulation in three different ways:

- Set an initial amount of LFO modulation, using the "LFO1 Int." parameter.
- Use "JS +Y Int." to adjust the amount of LFO produced by JS+Y operations.
- Use any AMS source to scale the amount of the LFO.

The results are added together to produce the total LFO effect.

LFO1 Intensity [−12.00...+12.00]

This controls the initial effect of the LFO on the pitch, in semitones, before any JS+Y Int. or AMS modulation.

Negative (−) settings will invert the phase of the LFO.

JS+Y Intensity [−12.00...+12.00]

Specify the depth of pitch modulation produced by OSC1 LFO1 when the joystick is moved in the +Y (away) direction (or when CC#1 is received). (Joystick control in the +Y direction is called "JS +Y.")

This parameter sets the maximum amount of LFO modulation added by JS+Y, in semitones.

As this value is increased, moving the joystick in the +Y direction will cause the OSC1 LFO1 to produce deeper pitch modulation.

Negative (−) settings will invert the phase of the LFO. You can also use this to reduce the initial amount of the LFO, as set by LFO1 Int., above. For example:

1. Set "LFO1 Int." to +7.00.
The LFO will now have a fairly strong effect on the pitch, bending it by a perfect 5th.
2. Set "JS+Y Int." to −7.00.
Now, if you move the joystick up, the effect of the LFO will fade away. When the joystick is all the way at the top of its range, the LFO will be completely cancelled out.

AMS (LFO1) [List of AMS Sources]

This selects any AMS modulation source to scale the amount of the LFO that's applied to pitch.

For a list of AMS sources, "AMS (Alternate Modulation Source) List" on page 287..

AMS Intensity [−12.00...+12.00]

This controls the depth and direction of the "AMS (LFO1)" modulation for pitch.

With a setting of 0, modulation will not be applied. With a setting of 12.00, the OSC1 LFO1 will apply a maximum of +/−1 octave of pitch modulation.

For example if "AMS (LFO1)" is set to JS+Y: CC#01 and you move the joystick in the +Y direction, pitch modulation from OSC1 LFO1 will be applied in positive phase if this is a positive (+) value, or applied in negative phase if this is a negative (−) value.

"LFO1 Int.," "JS+Y Int.," and "AMS (LFO1)" settings are summed to determine the depth and direction of pitch modulation produced by OSC1 LFO1.

LFO2

The parameters for LFO2 are identical to those for LFO1. For more information, please see the descriptions under LFO1, above.

OSC2 Multisample

This page controls the basic settings for Oscillator 2. It is available only when the Oscillator Mode is set to Double; if not, the page will be grayed out.

The parameters are identical to those for Oscillator 1, as described under "OSC1 Multisample" on page 89.

OSC2 Pitch

This page controls the pitch settings for Oscillator 2. It is available only when the Oscillator Mode is set to Double; if not, the page will be grayed out.

The parameters are identical to those for Oscillator 1, as described under "OSC1 Pitch" on page 91.

OSC Common

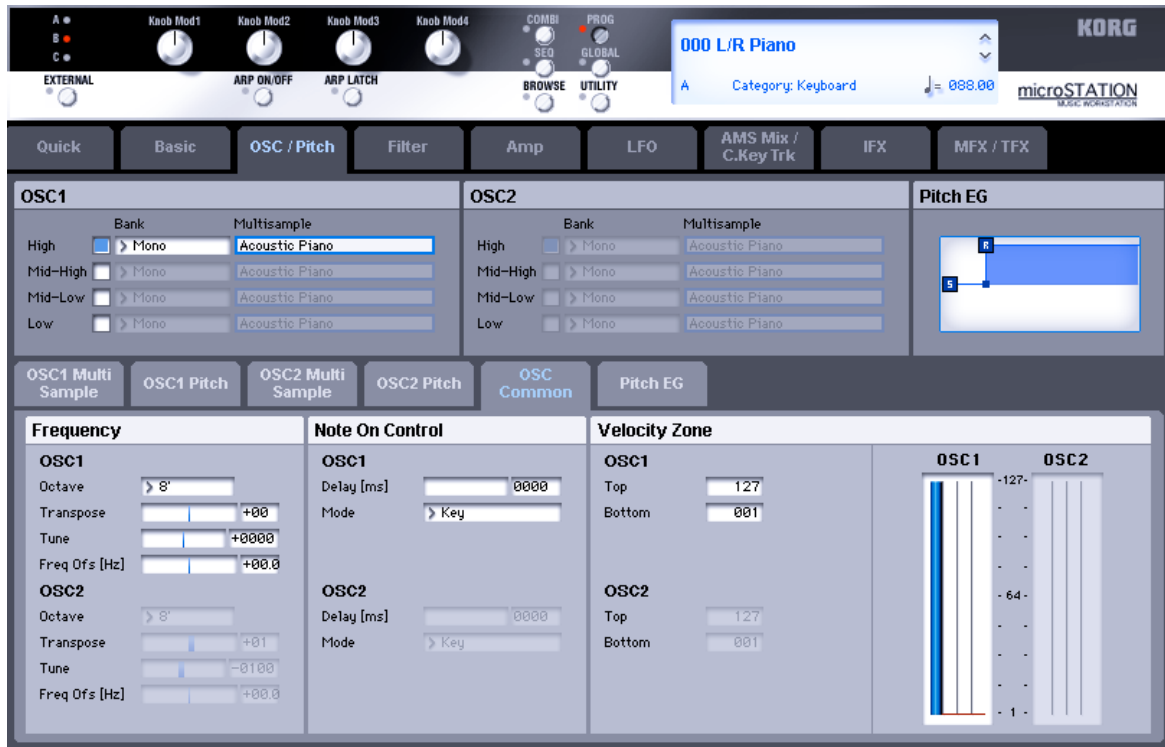

Here is where you can specify the pitch of each oscillator, the delay time until the oscillator will begin sounding, and the velocity zone.

Frequency

“Oscillator Mode” Single, Double

OSC1, OSC2

Octave [32', 16', 8', 4']

This sets the basic pitch of the Oscillator, in octaves. The default is +0[8']. The standard octave of a multisample is +0 [8'].

Transpose [-12...+12]

This adjusts the pitch in semitones, over a range of ± 1 octave.

Tune [-1200...+1200]

This adjusts the pitch in cents, over a range of ± 1 octave. A cent is 1/100 of a semitone.

Freq Ofz [Hz] (Frequency Offset)

[−10.0Hz ... +10Hz]

This adjusts the pitch by increments of 0.1 Hz. Frequency Offset is different from “Tune” in that, when used to detune the two oscillators, it can create a constant beat frequency across the range of the keyboard.

“Oscillator Mode” Drums

Octave [32', 16', 8', 4']

This adjusts the pitch in octave units. When using a drum kit, set the Octave to 8'.

⚠ When editing a drum program, you must set this parameter to 8'. With other settings, the sounds of the drum kit will be assigned to the wrong notes of the keyboard.

Transpose [-12...+12]

This adjusts the location of the instruments in the selected drum kit. Unless you need to change this, leave it at 0.

Tune [-1200...+1200]

This adjusts the pitch in one-cent units. The pitch of each drum kit can be adjusted in Global: Drum kit.

Freq Ofz [Hz] [-10.0Hz ... +10Hz]

This adjusts the pitch by increments of 0.1 Hz. Frequency Offset is different from “Tune” in that, when used to detune the two oscillators, it can create a constant beat frequency across the range of the keyboard.

Note-On Control

OSC1

Delay [ms] [0000ms...5000ms, KeyOff]

This specifies the time from when you press a key until oscillator 1 actually begins to sound.

This is most useful in Double Programs, for delaying one oscillator in relation to the other.

KeyOff is a special setting. Instead of delaying the sound by a particular amount of time, the sound will play as soon as you release the key. You can use this to create the "click" heard when a harpsichord note is released, for instance.

In general, when you use the KeyOff setting, it's also best to set the oscillator's Amp EG "Sustain Level" to 0.

Mode [Key, Key + Damper]

Normally, you play notes simply by pressing keys on the keyboard. In special cases, however, you can set this parameter so that you must first be holding down the damper pedal, and then press a key, in order to play a note. For instance, this can be useful when modeling the behavior of a piano soundboard.

Key is the normal mode.

When you select Key + Damper, notes will only sound if the damper pedal is being held down. When the damper pedal is released, all notes will be stopped—even if they are still being held down.

OSC2

Delay [ms] [0000ms...5000ms, KeyOff]

Mode [Key, Key + Damper]

This specifies the time from when you press a key until oscillator 2 actually begins to sound.

See "OSC1 Delay" and "Mode," above.

Velocity Zone

You can specify the velocity zone for each of the four multi-samples of the oscillator. Here you will specify the velocity zone for each oscillator.

These velocity zones take precedence over the velocity settings for the individual High-Low.

OSC1

OSC Top [001...127]

This sets the highest velocity where the Oscillator 1 will sound.

Note: The "OSC1 Top" velocity must be greater than the "OSC1 Bottom" velocity.

OSC Bottom [001...127]

This sets the lowest velocity where the Oscillator 1 will sound.

OSC2

OSC2 Top [001...127]

OSC2 Bottom [001...127]

This specifies the maximum and minimum velocity values where oscillator 2 will sound.

See "OSC1 Top" and "OSC1 Bottom," above.

OSC 1/2 Velocity Zone Window:

This shows the velocity zone.

This graphic reflects the OSC1 multisample and OSC2 multisample "Bottom Vel.," "Range," and "Curve," and the Velocity Zone "OSC1 Top," "OSC1 Bottom," "OSC2 Top," and "OSC2 Bottom settings."

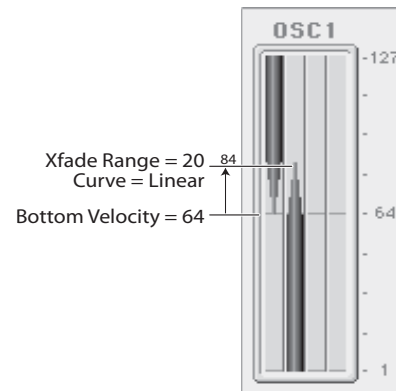

Pitch EG AMS Source



The Pitch EG, or Envelope Generator, lets you create complex, time-varying changes to the pitch of Oscillators 1 and 2. The parameters on this page control the shape of the EG. For instance, you can:

- Create the basic EG shape by setting the levels and times of each segment.
- Control the curvature of each EG segment, for subtle control over the modulation time of the EG.
- Set up complex modulation of EG levels and times.
- Set up an AMS source, such as an LFO, to restart the EG.

To control how much effect the EG has on the pitch, use the Pitch EG parameters on the OSC/Pitch- OSC1 Pitch page and OSC2 Pitch page, as described under "Pitch EG" on page 92.

Differences from the other EGs

The Pitch EG is different from the Filter and Amp EGs in several ways:

- The single Pitch EG is shared by both Oscillator 1 and Oscillator 2.
- The Sustain level is always 0.
- The Level modulation has two AMS sources instead of one, and the Time modulation has one AMS source instead of three.

Pitch EG is also an AMS source

You can use the Pitch EG as an AMS source to modulate other parameters, just like the keyboard tracking and LFOs. Simply select the Pitch EG in the AMS list for the desired parameter.

Envelope

Pitch EG

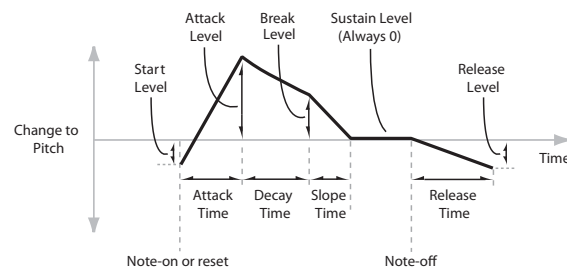

The envelope moves to a specified level over the specified time, and then moves to the next specified level over the specified time. It produces a modulation signal corresponding to this movement.

The parameters below let you set four levels, the amount of time it takes to go from each of the levels to the next, and the shape (from linear to curved) of each transition.

Time

Higher values mean longer times, as shown below:

EG Value	Actual Time
10	10 ms
20	44 ms
30	104 ms
40	224 ms
50	464 ms
60	944 ms
70	1.8 seconds
80	3.8 seconds

EG Value	Actual Time
90	10.9 seconds
99	87.3 seconds

Attack [00...99]

This sets how long the EG takes to move from the Start level to the Attack level.

For the fastest possible attack time, you can set the Start level to +99; in this case, the EG will start instantaneously at its maximum value.

Decay [00...99]

This sets the time it takes to move from the Attack level to the Break level.

Slope [00...99]

This sets how long the EG takes to move from the Break level to the Sustain level (which for the Pitch EG is always 0). Once it reaches the Sustain, the EG will stay there until note-off, unless it is reset via AMS.

Release [00...99]

This sets how long it takes the EG to move from the Sustain level to the Release level.

Level

Each of the four levels can be either positive or negative. Positive levels will make the pitch (or other AMS destination) go up from its programmed value; negative levels will make it go down.

Note that, unlike the Filter and Amp EGs, the Pitch EG's Sustain Level is always 0.

Start [-99...+99]

This sets the initial EG level at note-on.

Attack [-99...+99]

This sets the level at the end of the Attack time.

Break [-99...+99]

Break, short for Break Point, sets the level at the end of the Decay time.

Release [-99...+99]

This sets the level at the end of the Release time.

Curve

For the sake of simplicity, most of the diagrams in this manual show envelopes as being made out of straight lines. In actuality, though, envelopes are more likely to be made out of curves. In other words, each segment's level will change quickly at first, and then slow down as it approaches the next point. This tends to sound better than straight, linear segments. Classic analog synth envelopes made these curved shapes naturally. The microSTATION goes a step further than vintage synths, however, and lets you control the amount of curvature separately for each of the four envelope segments.

Pitch EG Curve

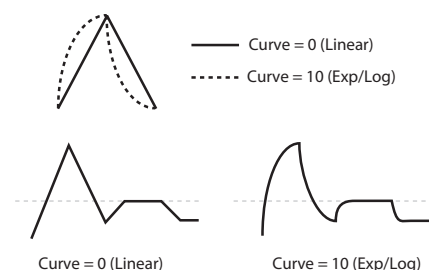

When you change the curvature, the EG times remain the same. However, greater curvature will tend to sound faster, because the value changes more quickly at the beginning.

Different curve settings for up and down

You may find that different amounts of curvature are suitable for segments which go up and segments which go down.

For instance, a curve of 3 is a good default setting for upward segments, such as Attack. On the other hand, a curve of 6 or more is good for downward segments, such as Decay and Release.

Attack [0L (Linear), 1...9, 10E (Exp/Log)]

This sets the curvature of the Attack segment - the transition from the Start level to the Attack level.

Decay [0L (Linear), 1...9, 10E (Exp/Log)]

This sets the curvature of the Decay segment - the transition from the Attack level to the Break level.

Slope [0L (Linear), 1...9, 10E (Exp/Log)]

This sets the curvature of the Slope segment - the transition from the Break level to the Sustain level (which for the Pitch EG is always 0).

Release [0L (Linear), 1...9, 10E (Exp/Log)]

This sets the curvature of the Release segment - the transition from the Sustain level to the Release level.

Level Modulation

These settings let you use two different AMS sources to control the Level parameters of the EG. For each of the two AMS sources, the Start, Attack, Decay, and Break levels each have their own modulation intensities.

By using different settings for each of the three levels, you can cause both subtle and dramatic changes to the EG shape, as shown below.

Note: Once the EG has started a segment between two points, that segment can no longer be modulated. This includes both the time of the segment, and the level reached at the end of the segment.

For instance, if the EG is in the middle of the Decay time, you can no longer modulate either the Decay time or the Break level.

This also means that modulating the Start level, Attack level, or Attack time will not affect notes that are already sounding, unless the EG is then re-started via EG Reset.

Pitch EG Level Modulation

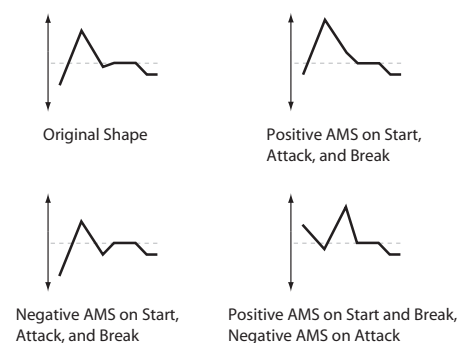

AMS1

Source [List of AMS Sources]

This selects the first AMS source to control the EG's Level parameters.

For a list of AMS sources, "AMS (Alternate Modulation Source) List" on page 287.

Start [-99...+99]

This controls the depth and direction of the AMS modulation for the Start level.

For example, if you set the AMS1 source to Velocity and set "Start" to +99, the Start level will increase as you play harder. If you set the "Start" to -99 instead, the Start level will decrease as you play harder.

Attack [-99...+99]

This controls the depth and direction of the AMS modulation for the Attack level.

Break [-99...+99]

This controls the depth and direction of the AMS modulation for the Break level.

AMS2

This selects the second AMS source for controlling the EG's Level parameters. The Start, Attack, Decay, and Break levels share this source, but each has its own modulation intensity. The parameters of AMS2 are identical to those of AMS1, above.

Time Modulation

These settings let you use an AMS source to control the Time parameters of the EG. The Attack, Decay, and Slope times share this AMS source, but each has its own modulation intensity.

Pitch EG Time Modulation

AMS=Velocity, Intensity = a positive (+) value

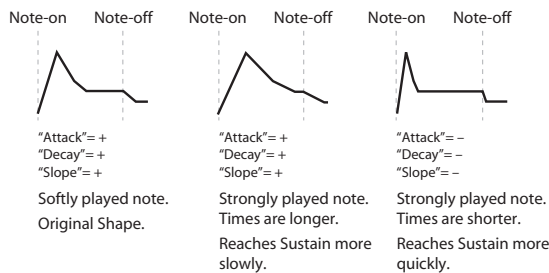

AMS

Source [List of AMS Sources]

This selects the AMS source to control the EG's Time parameters. Velocity and Keyboard Track can both be useful here, for instance.

For a list of AMS sources, please see "Alternate Modulation Source (AMS)" on page 287.

Attack [-99...+99]

This controls the depth and direction of the AMS modulation for the Attack time.

For example, if you set the AMS source to Velocity and set Attack to +99, the Attack time will get much longer at higher

velocities. If you set the Attack to -99 instead, the Attack time will get much shorter at higher velocities.

When the AMS source is at its maximum value—for instance, when Velocity is at 127—a setting of +8 will make the Attack time almost twice as long, and a setting of -8 will cut the Attack time almost in half.

Decay [-99...+99]

This controls the depth and direction of the AMS modulation for the Decay time.

Slope [-99...+99]

This controls the depth and direction of the AMS modulation for the Slope time.

EG Reset

AMS Source [List of AMS Sources]

This selects an AMS source to reset the EG to the start point. For instance, you can use a tempo-synced LFO to trigger the EG in a repeating rhythm. This reset is in addition to the initial note-on, which always causes the "Alternate Modulation Source (AMS)" on page 287.

Threshold [-99...+99]

This sets the AMS level which will trigger the EG reset.

When the "Threshold" is positive, the EG triggers when passing through the threshold moving upwards. When the "Threshold" is negative, the EG triggers when passing through the threshold moving downwards.

Note: For several LFO waveform types, or if the LFO cycle is fast, the LFO output may not always keep up with high values such as +99 or -99.

Filter

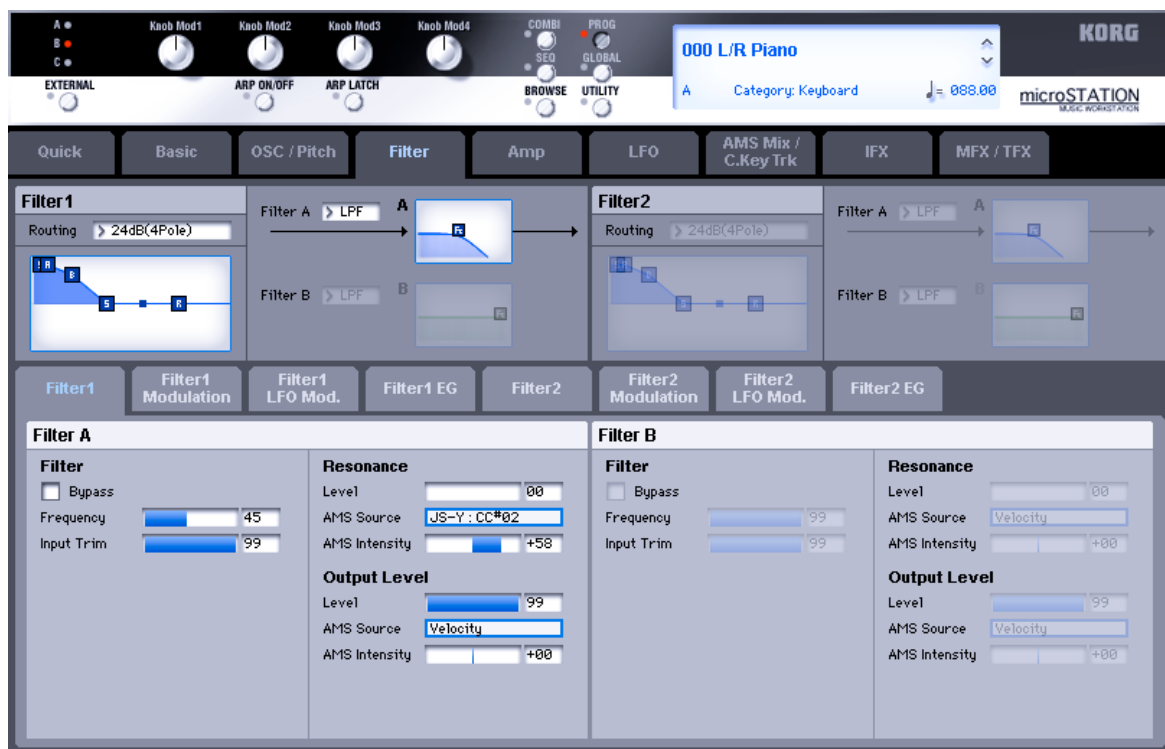

Filtering can make subtle or dramatic changes to the oscillator's timbre. Each oscillator has two multimode resonant filters, A and B, as well as a dedicated filter envelope and keyboard tracking generator.

These pages let you control all aspects of the filters. Among other things, you can:

- Adjust basic settings for each oscillator's filters, including routing, modes, cutoff, resonance, etc.
- Set up filter modulation, including keyboard tracking, the filter envelope, LFO modulation, and AMS control.

Note that when the "Oscillator Mode" is set to Single, only Oscillator 1's filters are active; the pages for Oscillator 2's filters will be grayed out.

Filter1

This page contains all of the basic settings for Oscillator 1's Filter A and Filter B. For example, you can:

- Set up the filters to produce a single 12 dB/oct filter, dual 12 dB/oct filters in either serial or parallel routing, or a single 24 dB/oct filter.
- Set each of the two filters to Low Pass, High Pass, Band Pass, or Band Reject modes.
- Set the cutoff, resonance, and input and output levels of each filter, including modulation of resonance and output level.

Routing [Single, Serial, Parallel, 24dB(4Pole)]

Each oscillator has two filters, Filter A and Filter B. This parameter controls whether one or both of the filters are used, and if both are used, it controls how they are connected to each other.

Single: This uses only Filter A as a single 2-pole, 12 dB/octave filter (6 dB for Band Pass and Band Reject). When this option is selected, the controls for Filter B will be grayed out.

Serial: This uses both Filter A and Filter B. The oscillator first goes through Filter A, and then the output of Filter A is processed through Filter B.

Parallel: This also uses both Filter A and Filter B. The oscillator feeds both filters directly, and the outputs of the two filters are then summed together.

24dB/oct: This merges both filters to create a single 4-pole, 24 dB/octave filter (12 dB for Band Pass and Band Reject). In comparison to Single, this option produces a sharper roll-off beyond the cutoff frequency, as well as a slightly more delicate resonance. Many classic analog synths used this general type of filter.

When 24 dB/oct is selected, only the controls for Filter A are active; the controls for Filter B will be grayed out.

Serial and Parallel Routing

Serial

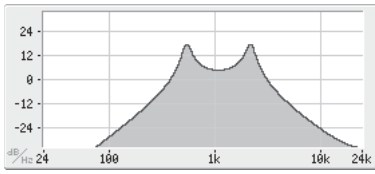
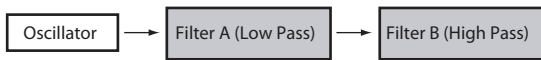

Parallel

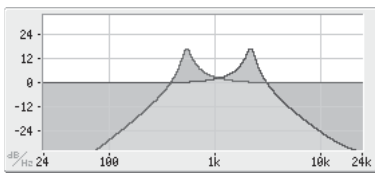
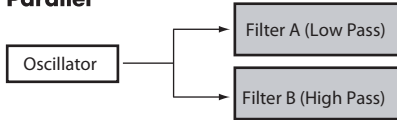

12db/oct / 24db/oct

Low Pass: 12dB/oct

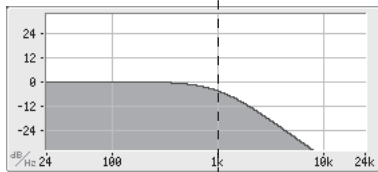

Low Pass: 24dB/oct

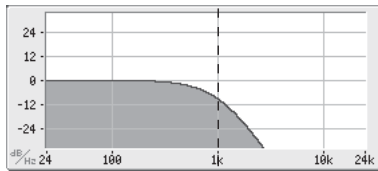

Filter A Type [LPF, HPF,BPF, BRF]

The filter will produce very different results depending on the selected filter type. The selections will change slightly according to the selected Filter Routing, to show the correct cutoff slope in dB per octave.

LPF: This cuts out the parts of the sound which are higher than the cutoff frequency. Low Pass is the most common type of filter, and is used to make bright timbres sound darker.

HPF: This cuts out the parts of the sound which are lower than the cutoff frequency. You can use this to make timbres sound thinner or more buzzy.

BPF: This cuts out all parts of the sound, both highs and lows, except for the region around the cutoff frequency. Since this filter cuts out both high and low frequencies, its effect can change dramatically depending on the cutoff setting and the oscillator's multisample.

With low resonance settings, you can use the Band Pass filter to create telephone or vintage phonograph sounds. With higher resonance settings, it can create buzzy or nasal timbres.

BRF: This filter type—also called a notch filter—cuts only the parts of the sound that are directly around the cutoff frequency. Try modulating the cutoff with an LFO to create phaser-like effects.

Filter Types and Cutoff Frequency

Low Pass

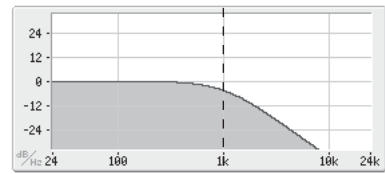

High Pass

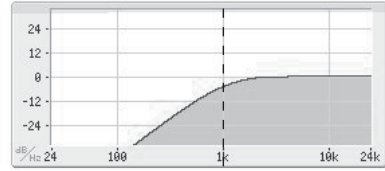

Band Pass

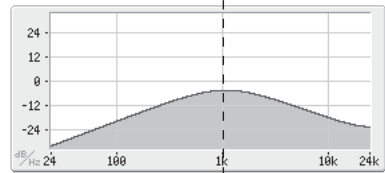

Band Reject

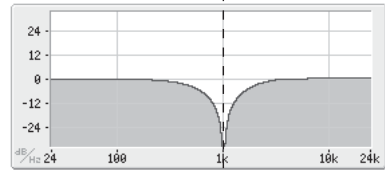

Cutoff Frequency

Filter B Type [LPF, HPF,BPF, BRF]

Filter B is available if the "Routing" is Serial or Parallel. Otherwise, all parameters in this section are unavailable, and cannot be edited.

The filter B parameters are the same as for filter A "Filter A Type" on page 100.

FilterA

Filter

Bypass [Off, On]

This lets you bypass Filter A completely. If Bypass is Off, Filter A functions normally. When Bypass is On, Filter A will have no effect.

Frequency [00...99]

This controls the cutoff frequency of Filter A, in increments of 1/10 of an octave. The specific effect of the cutoff frequency will change depending on the selected "Filter Type."

Input Trim [00...99]

This adjusts the volume level at the input to the filter. If you notice that the sound is distorting, especially with high Resonance settings, you can turn the level down here, or at the Output.

Resonance

Level [00...99]

Resonance emphasizes the frequencies that are around the cutoff frequency.

When this is set to 0, there is no emphasis, and frequencies beyond the cutoff will simply diminish smoothly.

At medium settings, the resonance will alter the timbre of the filter, making it sound more nasal, or more extreme.

At very high settings, the resonance can be heard as a separate, whistling pitch.

To make the resonance track the keyboard pitch, please see "Key Follow" on page 103.

AMS Source (Resonance) [List of AMS Sources]

This selects an AMS source to control the Resonance amount. For a list of AMS sources, "AMS (Alternate Modulation Source) List" on page 287.

AMS Intensity [-99...+99]

This controls the depth and direction of the Resonance modulation.

For example, if Velocity has been selected, changes in keyboard velocity will affect the resonance. With positive (+) values, the resonance will increase as you play more strongly, and as you play more softly the resonance will approach the level specified by the Resonance setting. With negative (-) values, the resonance will decrease as you play more strongly, and as you play more softly the resonance will approach the level specified by the Resonance setting.

The resonance level is determined by adding the Resonance and "AMS Intensity" values.

Output Level

Level [00...99]

This controls the output level of Filter A. You can use this to balance the volumes of Filters A and B when the Routing is set to Parallel, or to turn down the volume to avoid clipping later in the signal chain.

AMS Source [List of AMS Sources]

This selects a modulation source to control the output level of Filter A. For a list of AMS sources, please see "Alternate Modulation Source (AMS)" on page 287.

AMS Intensity [-99...+99]

This controls the depth and direction of the output level modulation.

Filter B

Filter B is available if the "Routing" is Serial or Parallel. Otherwise, all parameters in this section are unavailable, and cannot be edited.

The filter B parameters are the same as for filter A (see "Filter A" on page 100).

Filter2

This page controls Oscillator 2's basic filter 2 settings. It is available only when the Oscillator Mode is set to Double; if not, the page will be grayed out.

The parameters are identical to those for Oscillator 1, as described under "Filter1," on page 99.

Resonance

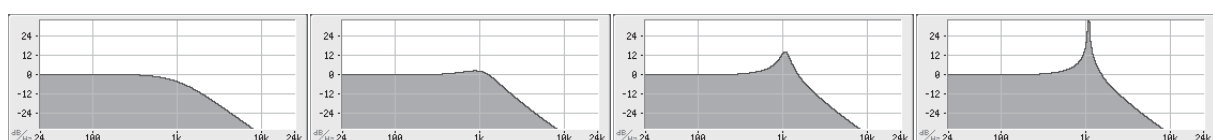

Low resonance value ←

→ High resonance value

Filter1 Modulation

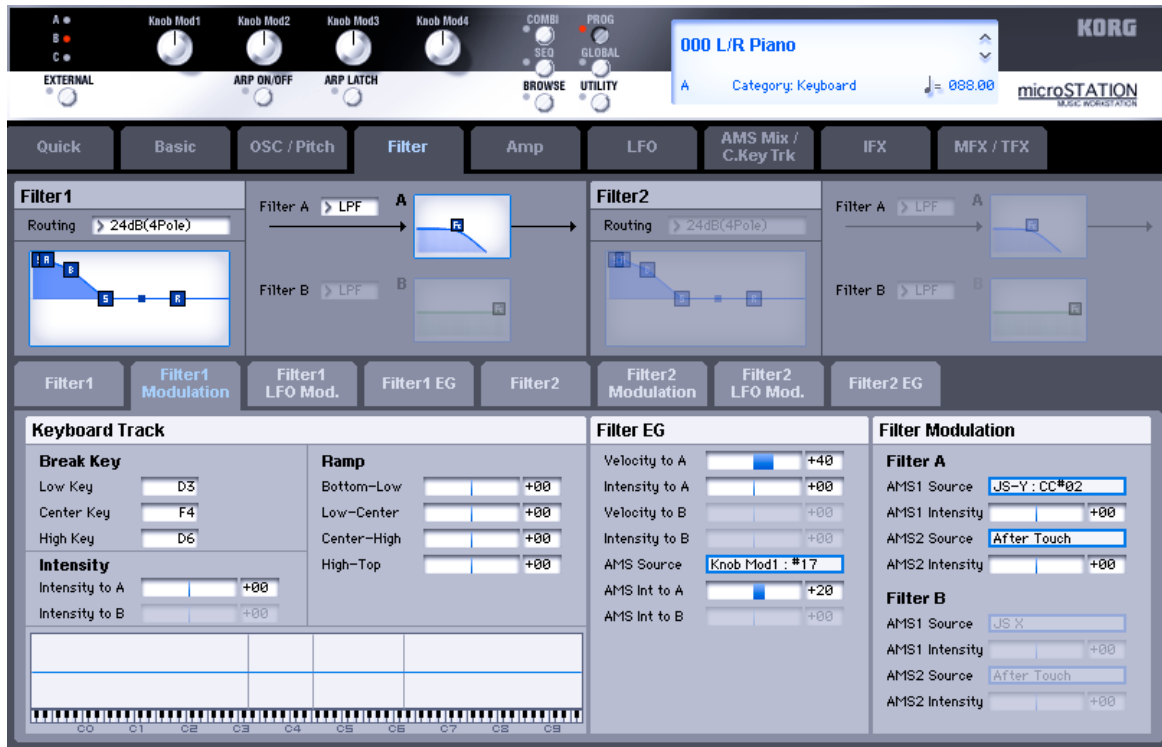

Here you can edit the filter keyboard tracking and filter modulation for oscillator 1. These settings include the following.

- Set up complex keyboard tracking shapes, and control how the tracking affects filter cutoff.
- Control the effect of the Filter Envelope on filter cutoff.
- Assign AMS modulation for filter cutoff.

Filter B is available when the Filter Routing is set to Serial or Parallel. Otherwise, the parameters for Filter B will be grayed out.

Keyboard Track

Most acoustic instruments get brighter as you play higher pitches. At its most basic, keyboard tracking re-creates this effect by raising the lowpass filter cutoff frequency as you play higher on the keyboard. Usually, some amount of key tracking is necessary in order to make the timbre consistent across the entire range.

The microSTATION keyboard tracking can also be much more complex, since it allows you to create different rates of change over up to four different parts of the keyboard.

How it works: Keys and Ramps

The keyboard tracking works by creating four ramps, or slopes, between five keys on the keyboard. The bottom and top keys are fixed at the bottom and top of the MIDI range, respectively. You can set the other three keys—named Key Low, Center, and Key High—to be anywhere in between.

The four Ramp values control the rate of change between each pair of keys. For instance, if the Lo Cent (Low-Center) Ramp is set to 0, the value will stay the same between the Key Low key and the Center key.

The Key value will be the break point, and the slope of the lower and higher regions on the keyboard is specified by the Ramp.

At the Center key (the main hinge), the keyboard tracking has no effect.

Break Key

Low Key [C-1...G9]

This specifies the note at which the two sloped lines in the lower range will be connected.

Center Key [C-1...G9]

This specifies the note that will be the break point for the center of keyboard tracking. At this key, the keyboard tracking has no effect on the filter cutoff, or on any AMS destinations.

High Key [C-1...G9]

This specifies the note where the two sloped lines in the upper range will be connected.

Intensity

Intensity to A [-99...+99]

This controls how much the keyboard tracking will affect Filter A's cutoff frequency. The overall effect of the Keyboard Track is a combination of this Intensity value and the overall Keyboard Track shape.

With positive values (+), the effect will be in the direction specified by keyboard tracking; if the ramp goes up, the filter cutoff will increase.

With negative values (-), the effect will be in the opposite direction; if the ramp goes up, the filter cutoff will decrease.

Keyboard Track Shape and Intensity

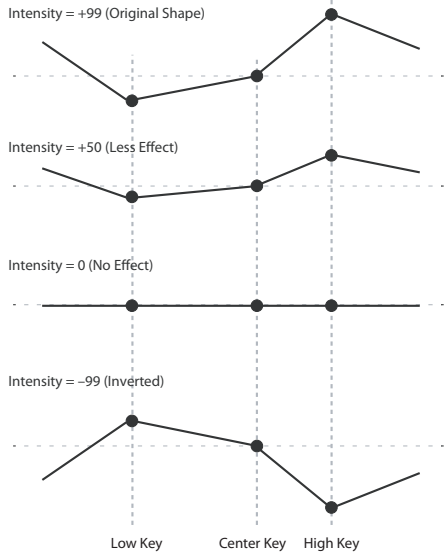

Intensity to B [-99...+99]

This controls how much the keyboard tracking will affect Filter B's cutoff frequency.

Ramp:

Positive ramp values mean that the keyboard tracking output increases as you play farther from the Center Key; negative ramp values mean that it decreases.

Because of this, the meanings of positive and negative ramp settings will change depending on whether the ramp is to the left or right of the Center Key.

Btm Lo (Bottom-Low) and Lo Cent (Low-Center): negative ramps make the keyboard tracking's output go down as you play lower on the keyboard, and positive ramps make the output go higher.

Cent Hi (Center-High) and Hi Top (High-Top): negative ramps make the keyboard tracking's output go down as you play higher on the keyboard, and positive ramps make the output go up.

The effect on the filter cutoff is a combination of the ramp values, as set below, and the Intensity to A (B) parameters. When Intensity to A (B) is set to +99, a ramp of 50 changes the filter frequency by 1 octave for every octave of the keyboard, and a ramp of +99 changes the frequency by 2 octaves for every octave of the keyboard.

Bottom-Low [-Inf, -99...+99, +Inf]

This sets the slope between the bottom of the MIDI note range and the Key Low key. For normal key track, use negative values.

Low-Center [-Inf, -99...+99, +Inf]

This sets the slope between the Key Low and Center keys. For normal key track, use negative values.

Center-High [-Inf, -99...+99, +Inf]

This sets the slope between the Center and Key High keys. For normal key track, use positive values.

High-Top [-Inf, -99...+99, +Inf]

This sets the slope between the Key High key and the top of the MIDI note range. For normal key track, use positive values.

+Inf and -Inf ramps

+Inf and -Inf are special settings which create abrupt changes for split-like effects. When a ramp is set to +Inf or -Inf, the keyboard tracking will go to its extreme highest or lowest value over the span of a single key.

+Inf and -Inf Ramps

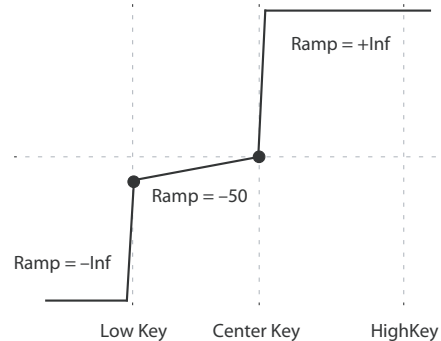

Note: If you set the Cent Hi ramp to +Inf or -Inf, the Hi Top parameter will be grayed out. Similarly, if you set the Lo Cent ramp to +Inf or -Inf, the Btm Lo ramp will be grayed out.

Key Follow

To create the classic Key Follow effect, in which the filter frequency tracks the pitch of the keyboard:

1. Set the Filter "Frequency" to 30.
2. Set the Keyboard Track "Intensity to A" to +99.
3. Set the "Bottom-Low" and "Lo-Center" ramps to -50.
4. Set the "Center High" and "High-Top" ramps to +50.
5. Set the "Center Key" to C4.
The settings for the "Low Key" and "High Key" don't matter in this case.

Filter Keyboard Track is also an AMS source

You can use the keyboard tracking as an AMS source to modulate other parameters, just like the envelopes and LFOs. Simply select Filter Kbd Trk in the AMS list for the desired parameter.

Filter EG

The Filter EG modulates the Filter A and B cutoff frequencies over time. You can control how strongly the EG will affect the filters in three different ways:

- Set an initial amount of EG modulation, using the Intensity to A and B parameters.
- Use velocity to scale the amount of the EG applied to the filter.
- Use any AMS source to scale the amount of the EG applied to the filter.

You can use all three of these at once, and the results are added together to produce the total EG effect.

To set up the EG itself, including attack and release times, levels, and so on, please see "Filter1 EG" on page 107.

Velocity to A [-99...+99]

This lets you use velocity to scale the amount of the Filter EG applied to Filter A.

Velocity control of Filter EG

In all examples below, Intensity to A = +50

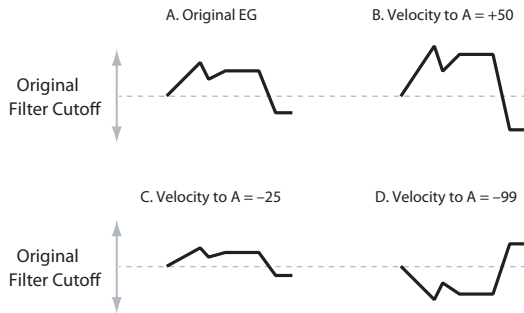

With positive (+) values, playing more strongly will increase the effect of the Filter EG, as shown in example B above.

With negative (-) values, playing more strongly will introduce the opposite effect of the Filter EG—like inverting the polarity of the envelope. You can use this in several different ways:

- You can set an initial positive amount with the Intensity to A/B parameters, and then reduce this amount with velocity. In this case, the final effect of the EG is simply diminished, and not actually inverted, as shown in example C above.
- You can also set the Velocity to A/B amounts so that they are greater than the initial amounts of Intensity to A/B. In this case, the EG will have a positive effect at low velocities, and an inverted effect at high velocities—as shown in example D.

Intensity to A [-99...+99]

This controls the initial effect of the Filter EG on Filter A's cutoff frequency, before any velocity or AMS modulation. The Filter EG's shape can swing all the way from +99 to -99. Positive values increase the cutoff frequency, and negative values decrease the cutoff frequency. For instance, please see the graphic "Velocity control of Filter EG," above. The EG shape in example A rises up at first, and then falls below 0 towards the end.

When "Intensity to A" is set to a positive (+) value, the EG's effect will match its shape. When the EG rises above 0, the cutoff frequency will increase.

With negative (-) values, the effect will be in the opposite direction; when the EG rises above 0, the filter cutoff will decrease.

Velocity to B [-99...+99]

This lets you use velocity to scale the amount of the Filter EG applied to Filter B. For more information, please see "Velocity to A," above.

Intensity to B [-99...+99]

This controls the initial effect of the Filter EG on Filter B's cutoff frequency, before any velocity or AMS modulation. For more information, please see "Intensity to A," above.

AMS Source (Filter EG) [List of AMS Sources]

This selects any AMS modulation source to scale the amount of the Filter EG applied to Filters A and B. The two filters share a single AMS source, with separate intensity settings. Otherwise, the AMS modulation will work in the same way as the Velocity to A parameter, described above.

For a list of AMS sources, please see "Alternate Modulation Source (AMS)" on page 287.

AMS Int to A [-99...+99]

This controls the depth and direction of the EG AMS modulation for Filter A.

AMS Int to B [-99...+99]

This controls the depth and direction of the EG AMS modulation for Filter B.

Filter Modulation

This section lets you assign any two AMS sources to control Filter A, and another two AMS sources to control Filter B. This modulation is added to the basic Filter A and B cutoff frequencies, as set on the Filter 1 page.

Filter A

AMS1 Source [List of AMS Sources]

This selects the first modulation source for controlling Filter A's cutoff frequency. For a list of AMS sources, please see "Alternate Modulation Source (AMS)" on page 287.

AMS1 Intensity [-99...+99]

This controls the depth and direction of AMS1.

AMS2 Source [List of AMS Sources]

This selects the second modulation source for controlling Filter A's cutoff frequency. For a list of AMS sources, please see "Alternate Modulation Source (AMS)" on page 287.

AMS2 Intensity [-99...+99]

This controls the depth and direction of AMS2.

Filter B

Filter B is available if the "Routing" is Serial or Parallel. Otherwise, all parameters in this section are unavailable, and cannot be edited.

The filter B parameters are the same as for filter A (☞ "Filter A" on page 100).

Filter1 LFO Mod.

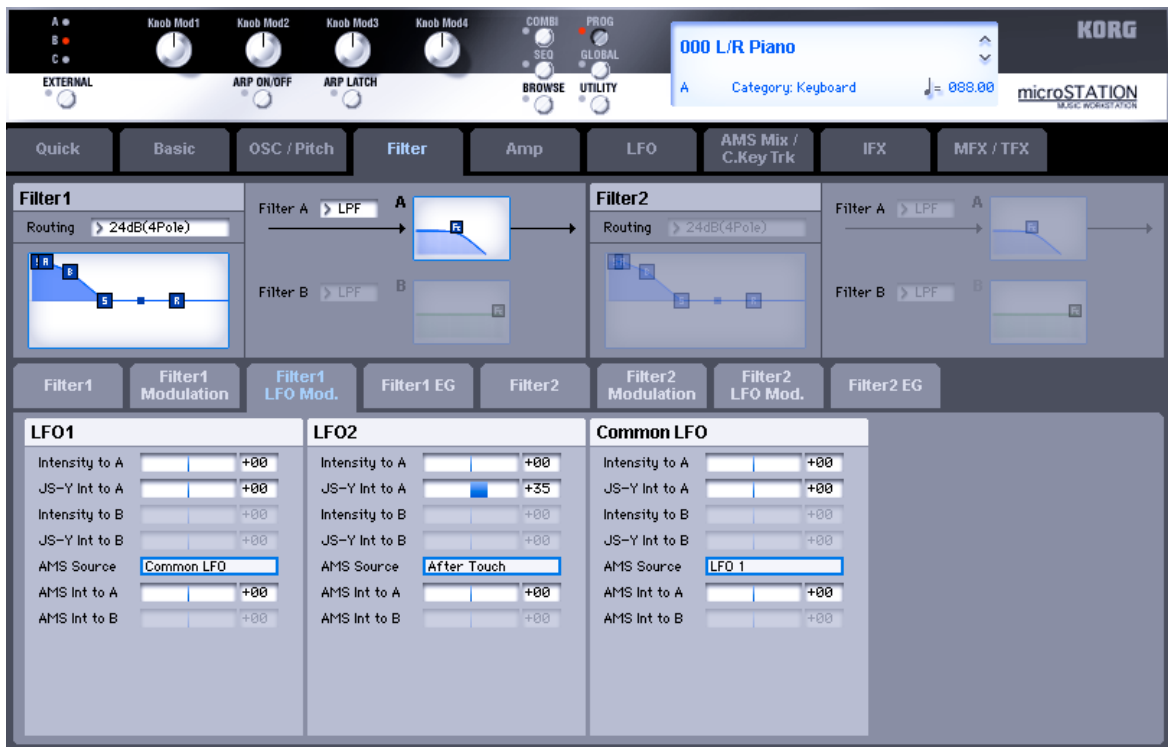

LFO1, LFO2, and the Common LFO can all modulate Filter A and B's cutoff frequencies. You can control the strength of each LFO's modulation independently for each filter, in three different ways:

- Set an initial amount of LFO modulation, using the Intensity to A and B parameters.
- Use JS-Y to scale the amount of the LFO.
- Use any AMS source to scale the amount of the LFO.

You can use each of these methods for each of the three LFOs, and do so separately for both Filter A and Filter B. The results are added together to produce the total LFO effect.

LFO 1

Intensity to A [-99...+99]

This controls the initial effect of the LFO on Filter A's cutoff frequency, before any "JS-Y Int to A" or "AMS" modulation.

Negative (-) settings will invert the phase of the LFO. You can produce interesting effects by using the same LFO to modulate two different parameters (such as Filter A and Filter B), but with one set to a positive intensity, and the other set to a negative intensity.

LFO modulation of Filter Cutoff

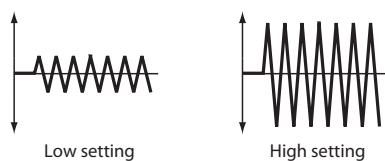

JS-Y Int to A [-99...+99]

This adjusts the depth of how the LFO will modulate the cutoff frequency of filter A when you move the joystick from the center in the -Y direction (toward yourself) (or when CC#2 is received). (Joystick control in the -Y direction is called "JS-Y".)

Negative (-) settings will invert the phase of the LFO. You can also use this to reduce the initial amount of the LFO, as set by "Intensity to A," above. For example:

1. Set Intensity to A to +50.
The LFO will now have a fairly strong effect on the filter cutoff.
2. Set JS-Y Intensity to A to -50.
Now, if you move the joystick down, the effect of the LFO will fade away. When the joystick is all the way at the bottom of its range, the LFO will be completely cancelled out.

Intensity to B [-99...+99]

This controls the initial effect of the LFO on Filter B's cutoff frequency, before any JS-Y or AMS modulation.

JS-Y Int to B [-99...+99]

This lets you use JS-Y to scale the amount of the LFO applied to Filter B. (See "JS-Y Int to A" on page 105)

AMS Source (LFO1) [List of AMS Sources]

This selects any AMS modulation source to scale the amount of the LFO applied to Filters A and B. The two filters share a single AMS source, but with separate intensity settings.

For a list of AMS sources, please see "Alternate Modulation Source (AMS)" on page 287.

AMS Int to A **[-99...+99]**

This controls the depth and direction of the LFO1 AMS modulation for Filter A.

For example, if AMS is set to JS+Y: CC#01, positive settings mean that YS+Y will increase the amount of LFO1 applied to Filter A.

AMS Int to B **[-99...+99]**

This controls the depth and direction of the LFO1 AMS modulation for Filter B.

LFO 2

The parameters for LFO2 are identical to those for LFO1. For more information, please see the descriptions under LFO1, above.

Common LFO

The parameters for the Common LFO are identical to those for LFO1. For more information, please see the descriptions under LFO1, above.

Note that while LFO1 and LFO2 are separate for each voice, the Common LFO is shared by all voices in the Program. This makes it useful when you want all of the voices to have an identical LFO effect.

Filter1 EG

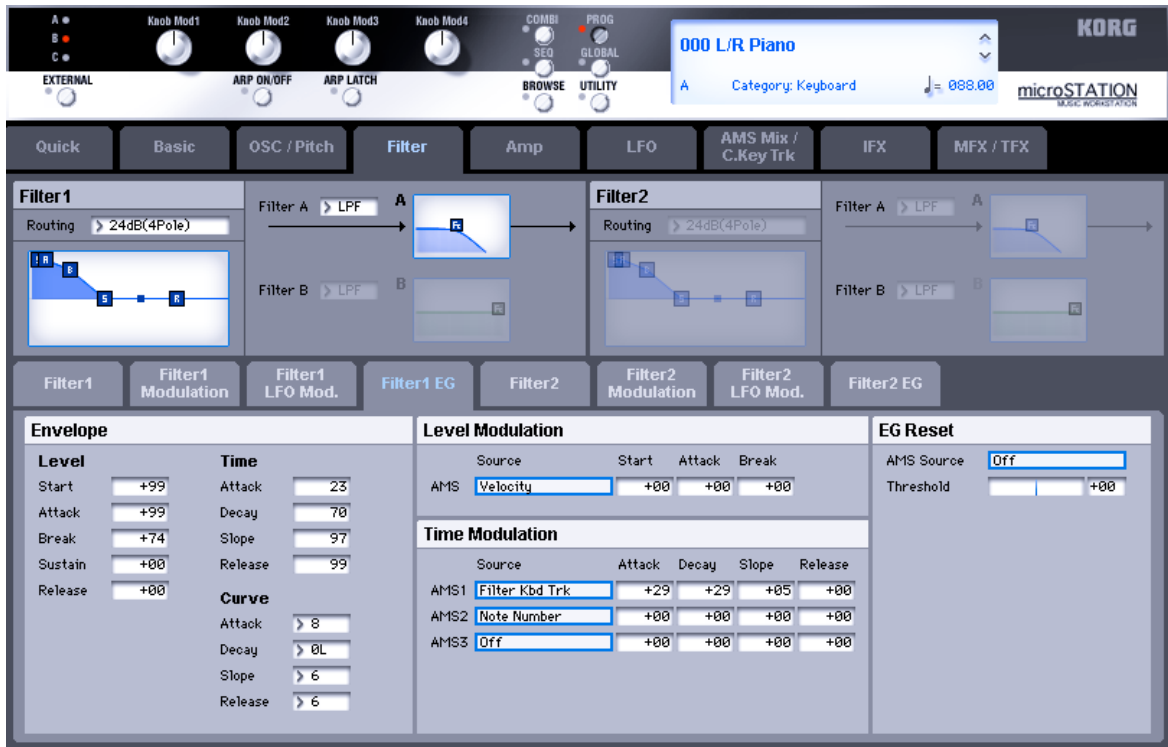

The Filter EG, or Envelope Generator, lets you create complex, time-varying changes to the cutoff frequencies of Filters A and B. The parameters on this page control the shape of the EG. Among other things, you can:

- Create the basic EG shape by setting the levels and times of each segment.
- Control the curvature of each EG segment, for subtle control over the modulation shape of the EG.
- Set up complex modulation of EG levels and times.
- Set up an AMS source, such as an LFO, to restart the EG.

To control how much effect the EG has on the filters, use the Filter EG parameters on the Filter1 Modulation page, as described under (“Filter EG” on page 6).

Filter EG is also an AMS source

You can use the Filter EG as an AMS source to modulate other parameters, just like the keyboard tracking and LFOs. Simply select the Filter EG in the AMS list for the desired parameter.

Envelope

Filter EG

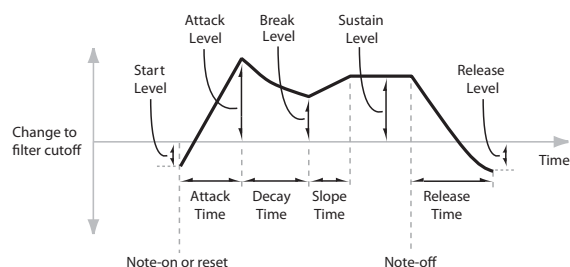

An envelope creates a modulation signal by moving from one level to another over a specified time, and then moving to another level over another period of time, and so on.

The parameters below let you set five levels, the amount of time it takes to go from each of the levels to the next, and the shape (from linear to curved) of each transition.

Level

Each of the five levels can be either positive or negative.

Positive levels will make the cutoff frequency (or other AMS destination) go up from its programmed value; negative levels will make it go down.

Start

[−99...+99]

This sets the initial EG level at note-on.

Attack

[−99...+99]

This sets the level at the end of the Attack time.

Break

[−99...+99]

Break, short for Break Point, sets the level at the end of the Decay time.

Sustain

[−99...+99]

This sets the level at the end of the Slope time. Once it reaches the Sustain level, the EG will stay there until note-off, unless it is reset via AMS.

Release

[−99...+99]

This sets the level at the end of the Release time.

Time

Higher values mean longer times, as shown below:

EG Value	Actual Time
10	10 ms
20	44 ms
30	104 ms
40	224 ms
50	464 ms
60	944 ms
70	1.8 seconds
80	3.8 seconds
90	10.9 seconds
99	87.3 seconds

Attack [00...99]

This sets how long the EG takes to move from the Start level to the Attack level.

For the fastest possible attack time, you can set the Start level to +99; in this case, the EG will start instantaneously at its maximum value.

Decay [00...99]

This sets the time it takes to move from the Attack level to the Break level.

Slope [00...99]

This sets how long the EG takes to move from the Break level to the Sustain level. Once it reaches the Sustain level, the EG will stay there until note-off (unless it is reset via AMS).

Release [00...99]

This sets how long it takes the EG to move from the Sustain level to the Release level.

Curve

The explanation of the filter EG curve is same as for pitch EG curve.

See "Curve" on page 97.

Attack [0L (Linear), 1...9, 10E (Exp/Log)]

This sets the curvature of the Attack segment - the transition from the Start level to the Attack level.

Decay [0L (Linear), 1...9, 10E (Exp/Log)]

This sets the curvature of the Decay segment - the transition from the Attack level to the Break level.

Slope [0L (Linear), 1...9, 10E (Exp/Log)]

This sets the curvature of the Slope segment - the transition from the Break level to the Sustain level.

Release [0L (Linear), 1...9, 10E (Exp/Log)]

This sets the curvature of the Release segment - the transition from the Sustain level to the Release level.

Level Modulation

These settings let you use any AMS source to control the Level parameters of the EG. The Start, Attack, and Break levels share a single AMS source, but can each have different modulation intensities.

(☞ "Level Modulation" on page 97)

AMS

Source [List of AMS Sources]

Selects an AMS source to control the EG's Level parameters.

For a list of AMS sources, please see "Alternate Modulation Source (AMS)" on page 287.

Start [-99...+99]

This controls the depth and direction of the AMS modulation for the Start level.

For example, if you set the AMS source to Velocity and set "Start" to +99, the Start level will increase as you play harder. If you instead set "Start" to -99, the start level will decrease as you play harder.

Attack [-99...+99]

This controls the depth and direction of the AMS modulation for the Attack level.

Break [-99...+99]

This controls the depth and direction of the AMS modulation for the Break level.

Time Modulation

These settings let you use three different AMS sources to control the Time parameters of the EG. For each of the three AMS sources, the Attack, Decay, Slope, and Release times each have their own modulation intensities.

Filter EG Time Modulation

AMS=Velocity, Intensity = a positive (+) value

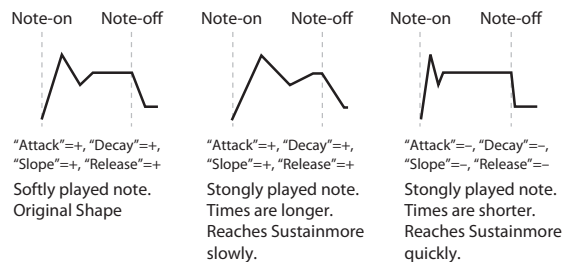

AMS1

Source [List of AMS Sources]

Selects the first AMS source to control the EG's Time parameters. Velocity and Keyboard Track can both be useful here, for instance.

For a list of AMS sources, please see "Alternate Modulation Source (AMS)" on page 287.

Attack [-99...+99]

This controls the depth and direction of the AMS modulation for the Attack time.

For example, if you set the AMS source to Velocity and set "Attack" to +99, the Attack time will get much longer at higher velocities. If you instead set "Attack" to -99, the Attack time will get much shorter at higher velocities.

When the AMS source is at its maximum value—for instance, when “Velocity” is at 127—a setting of +8 will make the Attack time almost twice as long, and a setting of –8 will cut the Attack time almost in half. (See p.291)

Decay **[–99...+99]**

This controls the depth and direction of the AMS modulation for the Decay time.

Slope **[–99...+99]**

This controls the depth and direction of the AMS modulation for the Slope time.

Release **[–99...+99]**

This controls the depth and direction of the AMS modulation for the Release time.

AMS2, AMS3

These select the second and third AMS sources, respectively, for controlling the EG’s Time parameters. Each has its own intensities for Attack, Decay, Slope, and Release. The parameters of both AMS2 and AMS3 are identical to those of AMS1, above.

EG Reset

AMS Source **[List of AMS Sources]**

This selects an AMS source to reset the EG to the start point.

(☞ “AMS Source” on page 98)

(☞ “AMS (Alternate Modulation Source) List” on page 287)

Threshold **[–99...+99]**

This sets the AMS level which will trigger the EG reset.

(☞ “Threshold” on page 98)

Filter2

Filter2

This page controls Oscillator 2’s basic filter 2 settings. It is available only when the Oscillator Mode is set to Double; if not, the page will be grayed out.

The parameters are identical to those for Oscillator 1.

(☞ “Filter1” on page 99)

Filter2 Modulation

This page controls Oscillator 2’s filter modulation. It is available only when the Oscillator Mode is set to Double; if not, the page will be grayed out.

The parameters are identical to those for Oscillator 1.

(☞ “Filter1 Modulation” on page 102)

Filter2 LFO Mod.

This page controls Oscillator 2’s LFO filter modulation. It is available only when the Oscillator Mode is set to Double; if not, the page will be grayed out.

The parameters are identical to those for Oscillator 1, as described under ?3–1–4: LFO Mod. (Modulation),? on page 36.

(☞ “Filter1 LFO Mod.” on page 105)

Filter2 EG

This page controls Oscillator 2’s Filter EG. It is available only when the Oscillator Mode is set to Double; if not, the page will be grayed out.

The parameters are identical to those for Oscillator 1.

(☞ “Filter1 EG” on page 107)

Amp



Oscillators 1 and 2 have separate controls for volume (also called “amplitude,” or “amp” for short); pan; and as well as dedicated amp envelopes and keyboard tracking generators.

These pages let you control all of these related parameters. Among other things, you can:

- Set the pan position and pan modulation.
- Control amp level and modulation, including keyboard tracking, the amp envelope, LFO modulation, and AMS control.

Note Note that when the Oscillator Mode is set to Single, only Oscillator 1’s amp and pan are active; the pages for Oscillator 2 will be grayed out.

Amp1

This page controls the basic settings for the Amp section. Here, you can:

- Set the initial volume level.
- Control the pan position and pan modulation.

Level [000...127]

This controls the basic volume level of Oscillator 1, before keyboard tracking, velocity, and other modulation.

The OSC Mixer and volume

You can control the Oscillator volume directly *f* in the OSC Mixer page (p.76). This is a separate parameter, in addition to “Amp Level.”

MIDI and volume

MIDI You can control the Program’s overall volume via MIDI using both Volume (CC#7) and Expression (CC#11). When used one at a time, the two controllers work in exactly the same way: a MIDI value of 127 is equal to the Amp “Level” setting, and lower values reduce the volume.

If both CC#7 and CC#11 are used simultaneously, the one with the lower value determines the maximum volume, and the one with the higher value scales down from that maximum.

This is controlled on the global MIDI channel (p.60).

Pan [RND, L001...C064...R127]

This controls the stereo pan of Oscillator 1. A setting of L001 places the sound at the far left, C064 in the center, and R127 to the far right.

When this is set to RND, the pan position will be different for each note-on.

MIDI You can also control pan via MIDI Pan (CC#10). A CC#10 value of 0 or 1 places the sound at the far left, 64 places the sound at the location specified by the Pan parameter, and 127 places the sound at the far right. This is controlled on the global MIDI channel (p.60).

Pan AMS Source [List of AMS Sources]

This selects an AMS source to modulate Pan. For a list of AMS sources, please see “Alternate Modulation Source (AMS)” on page 287.

Pan AMS Intensity [–99...+99]

This controls the depth and direction of the AMS modulation for Pan.

For example, if “Pan” is set to C064 and “Pan AMS Source” is set to Note Number, positive (+) intensities will cause the sound to move toward the right as you play higher than C4,

and toward the left as you play lower than C4. Negative (-) intensities will have the opposite effect.

Use DKit Setting [Off, On]

This option is available only when the Oscillator Mode is set to Drums.

Unlike standard Programs, Drum Kits can have a different pan setting for every note. This parameter lets you choose whether to use the Drum Kit pan settings, or to use the Program's pan setting instead.

On: The Program will use the Drum Kit's per-note pan settings; pan AMS will still apply. This is the default setting.

Off: The Program will ignore the Drum Kit's settings, and use the Program pan instead.

All keys of the drum kit will use the Pan (p.191) setting.

Amp2

This page controls Oscillator 2's basic level and Pan settings. It is available only when the "Oscillator Mode" is set to Double; if not, the page will be grayed out.

The parameters are identical to those for Oscillator 1 (p. "Amp1" on page 110).

Amp1 Modulation

This page contains the settings for Oscillator 1's Amp level modulation. Among other things, you can:

- Set up complex keyboard tracking shapes to control the Amp level.
- Assign AMS modulation for the Amp level.
- Control the effect of the LFOs on the Amp level.

The total effect of the modulation can increase the volume to a maximum of two times louder than the Amp "Level" setting.

Keyboard Track

Keyboard tracking lets you vary the volume as you play up and down the keyboard. Usually, some amount of key tracking is necessary in order to make the volume consistent across the entire range.

Amp Keyboard Tracking

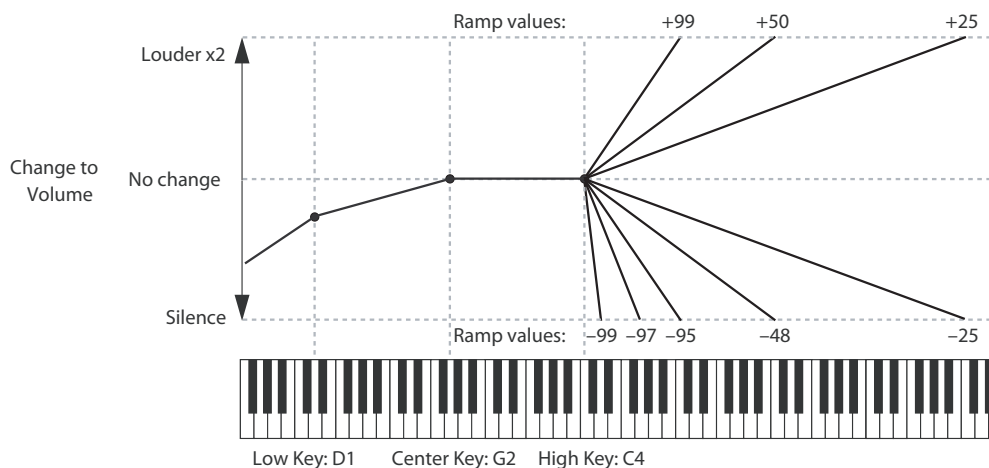

microSTATION's keyboard tracking can be fairly complex, if desired. You can create different rates of change over up to four different parts of the keyboard. For instance, you can:

- Make the volume increase very quickly over the middle of the keyboard, and then increase more slowly—or not at all—in the higher octaves.
- Make the volume increase as you play lower on the keyboard.
- Create abrupt changes at certain keys, for split-like effects.

How it works: Keys and Ramps

The keyboard tracking works by creating four ramps, or slopes, between five keys on the keyboard.

"Break Key" on page 102

Break Key:

Low Key [C-1...G9]

Center Key [C-1...G9]

High Key [C-1...G9]

"Break Key" on page 102

Ramp:

See "Ramp:" on page 103.

Differences from other Keyboard Tracks

There are several differences between the Amp keyboard tracking and the Filter and Common keyboard tracking.

For example, the results of the Ramp values are different. As shown in the graphic "Amp Keyboard Tracking," below, negative slopes are more steep than positive slopes.

Also, the amp does not have separate control of Intensity. Instead, Intensity is always fixed at the maximum amount, allowing keyboard tracking to change the volume from complete silence to twice as loud as the programmed level.

Bottom-Low [-Inf, -99...+99, +Inf]

This sets the slope between the bottom of the MIDI note range and the Key Low key. For normal key track, use negative values.

Low-Center [-Inf, -99...+99, +Inf]

This sets the slope between the Key Low and Center keys. For normal key track, use negative values.

Center-High [-Inf, -99...+99, +Inf]

This sets the slope between the Center and Key High keys. For normal key track, use positive values.

High-Top [-Inf, -99...+99, +Inf]

This sets the slope between the Key High key and the top of the MIDI note range. For normal key track, use positive values.

Ramp	Change in level
-Inf	Silent in one half-step
-99	Silent in one whole-step
-95	Silent in one octave
-48	Silent in two octaves
-25	Silent in four octaves
00	no change
+25	x2 in four octaves
+50	x2 in two octaves
+99	x2 in one octave
+Inf	x2 in one half-step

+Inf and -Inf ramps

+Inf and -Inf are special settings which create abrupt changes for split-like effects. When a ramp is set to +Inf or -Inf, the keyboard tracking will go to its extreme highest or lowest value over the span of a single key.

When a ramp is set to +Inf, the keyboard tracking will go to its highest value (double the programmed volume) over a single half-step.

Similarly, when a ramp is set to -Inf, the keyboard tracking will go to its lowest value (complete silence) over a single half-step.

If you set the "Center-High" ramp to +Inf or -Inf, the "High-Top" parameter will be grayed out. Similarly, if you set the "Low-Center" ramp to +Inf or -Inf, the "Bottom-Low" ramp will be grayed out.

Amp KTrk is also an AMS source

You can use the keyboard tracking as an AMS source to modulate other parameters, just like the envelopes and LFOs. Simply select Amp KbdTrk in the AMS list for the desired parameter.

Amp Modulation

You can modulate the Amp level by both velocity and an AMS source.

This modulation scales the basic Amp level and Amp EG level parameters. The resulting volume is determined by multiplying the volume changes of the amp EG by other values such as AMS. If these original levels are low, the maximum volume available with modulation will also be reduced.

Velocity

Intensity [-99...+99]

With positive (+) values, the volume will increase as you play harder.

With negative (-) values, the volume will decrease as you play harder.

Velocity modulation of Amp level, with Amp EG

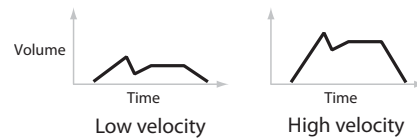

AMS Source [List of AMS Sources]

This selects any AMS modulation source to control the Amp1 level. For a list of AMS sources, please see "Alternate Modulation Source (AMS)" on page 287.

AMS Intensity [-99...+99]

This controls the depth and direction of the modulation. For example, if "AMS Source" is set to JS+Y: CC#01, positive (+) values of this parameter will make the volume increase when move the joystick in the +Y direction.

Note that if the other modulation settings have already raised the volume to its maximum level (double the Amp Level and Amp EG level settings), the volume cannot be increased any further.

LFO1

Intensity [-99...+99]

This controls the depth and direction of LFO1's effect on the oscillator's volume.

Negative (-) values will invert the LFO waveform.

AMS Source [List of AMS Sources]

This selects an AMS modulation source to scale the amount of the LFO1 applied to the Amp level. For a list of AMS sources, please see "Alternate Modulation Source (AMS)" on page 287.

AMS Intensity [-99...+99]

This controls the depth and direction of the LFO1 AMS modulation for the Amp level.

LFO2

The parameters for LFO2 are identical to those for LFO1. For more information, please see the descriptions under LFO1, above.

Amp1 EG



These parameters let you create time-varying changes in the volume of oscillator 1.

Envelope

These parameters specify how the amp 1 EG will change over time.

Amp EG

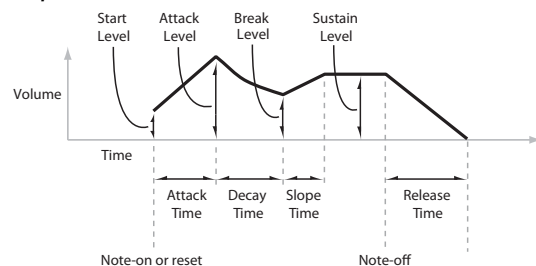

Level:

Start [00...99]

This sets the initial volume level at note-on.

Attack [00...99]

This sets the level at the end of the Attack time.

Break [00...99]

Break, short for Break Point, sets the level at the end of the Decay time.

Sustain [00...99]

This sets the level at the end of the Slope time. Once it reaches the Sustain level, the EG will stay there until note-off (unless it is reset via AMS).

Time:

Higher values mean longer times, as shown below.

EG Value	Actual Time
10	10 ms
20	44 ms
30	104 ms
40	224 ms
50	464 ms
60	944 ms
70	1.8 seconds
80	3.8 seconds
90	10.9 seconds
99	87.3 seconds

Attack [00...99]

This sets how long the EG takes to move from the Start level to the Attack level.

For the fastest possible attack time, you can set the Start level to +99; in this case, the EG will start instantaneously at its maximum value.

Decay [00...99]

This sets the time it takes to move from the Attack level to the Break level.

Slope [00...99]

This sets how long the EG takes to move from the Break level to the Sustain level. Once it reaches the Sustain level, the EG will stay there until note-off (unless it is reset via AMS).

Release [00...99]

This sets how long it takes the EG to move from the Sustain level to silence.

Curve

The explanation of the amp EG curve is same as for pitch EG curve.

See "Curve" on page 97.

Attack [0L (Linear), 1...9, 10E (Exp/Log)]

This sets the curvature of the Attack segment - the transition from the Start level to the Attack level.

Decay [0L (Linear), 1...9, 10E (Exp/Log)]

This sets the curvature of the Decay segment - the transition from the Attack level to the Break level.

Slope [0L (Linear), 1...9, 10E (Exp/Log)]

This sets the curvature of the Slope segment - the transition from the Break level to the Sustain level.

Release [0L (Linear), 1...9, 10E (Exp/Log)]

This sets the curvature of the Release segment - the transition from the Sustain level to the Release level.

Level Modulation

These settings let you use any AMS source to control the Level parameters of the EG. The Start, Attack, and Break levels share a single AMS source, but can each have different modulation intensities.

☞ "Level Modulation" on page 97

AMS

Source [List of AMS Sources]

This selects an AMS source to control the EG's Level parameters.

For a list of AMS sources, please see "Alternate Modulation Source (AMS)" on page 287.

Start [-99...+99]

This controls the depth and direction of the AMS modulation for the Start level.

For example, if you set the AMS source to Velocity and set "Start" to +99, the Start level will increase as you play harder. If you instead set "Start" to -99, the Start level will decrease as you play harder.

Attack [-99...+99]

This controls the depth and direction of the AMS modulation for the Attack level.

Break [-99...+99]

This controls the depth and direction of the AMS modulation for the Break level.

Time Modulation

These settings let you use three different AMS sources to control the Time parameters of the EG. For each of the three AMS sources, the Attack, Decay, Slope, and Release times each have their own modulation intensities.

Amp EG Time Modulation

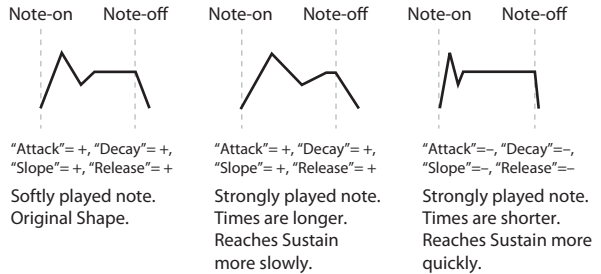

AMS1

Source [List of AMS Sources]

Selects the first AMS source to control the EG's Time parameters. Velocity and Keyboard Track can both be useful here, for instance.

For a list of AMS sources, please see "Alternate Modulation Source (AMS)" on page 287.

Attack [-99...+99]

This controls the depth and direction of the AMS modulation for the Attack time.

For example, if you set the AMS source to Velocity and set At (Attack) to +99, the Attack time will get much longer at higher velocities. If you instead set At (Attack) to -99, the Attack time will get much shorter at higher velocities.

When the AMS source is at its maximum value—for instance, when Velocity is at 127—a setting of +8 will make the segment time almost twice as long, and a setting of -8 will cut the segment time almost in half.

Decay [-99...+99]

This controls the depth and direction of the AMS modulation for the Decay time.

Slope [-99...+99]

This controls the depth and direction of the AMS modulation for the Slope time.

Release [-99...+99]

This controls the depth and direction of the AMS modulation for the Release time.

AMS2, AMS3

These select the second and third AMS sources, respectively, for controlling the EG's Time parameters. Each has its own intensities for Attack, Decay, Slope, and Release. The parameters of both AMS2 and AMS3 are identical to those of AMS1, above.

EG Reset

AMS [List of AMS Sources]

This selects an AMS source to reset the EG to the start point.

☞“AMS Source” on page 98

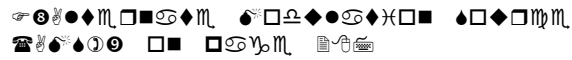

Threshold [-99...+99]

This sets the AMS level which will trigger the EG reset.

☞“Threshold” on page 98

Amp2 Modulation

This page controls Oscillator 2’s amp modulation. It is available only when the Oscillator Mode is set to Double; if not, the page will be grayed out.

The parameters are identical to those for Oscillator 1 (☞“Amp1 Modulation” on page 111).

Amp2 EG

This page controls Oscillator 2’s amp EG. It is available only when the Oscillator Mode is set to Double; if not, the page will be grayed out.

The parameters are identical to those for Oscillator 1 (☞“Amp1 EG” on page 113).

LFO

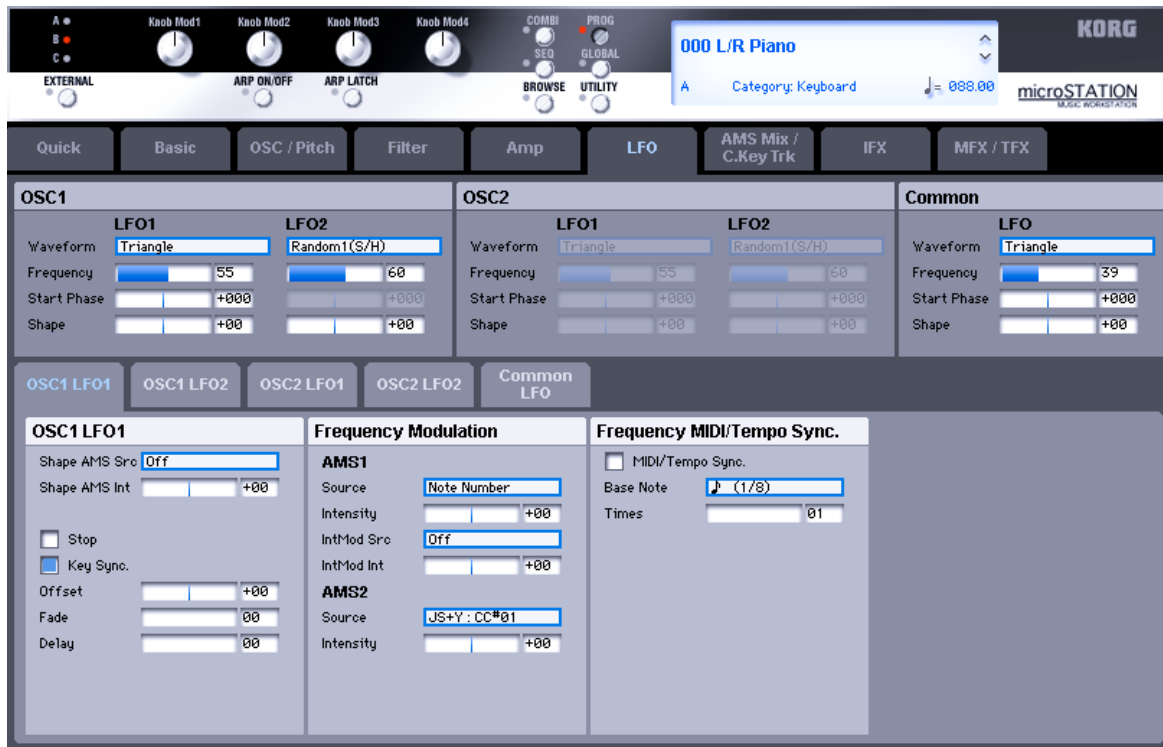

Each of the Oscillators 1, 2 has two LFOs, which you can use to modulate the filter, amp, pitch, and many other parameters.

The two Oscillators also share a single Common LFO, similar to the global LFO on some vintage analog synths.

These pages let you set up all of the parameters for all five LFOs.

OSC 1

Here you can specify the LFO1 and LFO2 waveforms for oscillator 1. These settings allow you to do the following things.

- Select the basic waveform for LFO1 and 2, and use “Shape” to modify it.
- Specify the frequency for LFO1 and 2.

LFO waveform

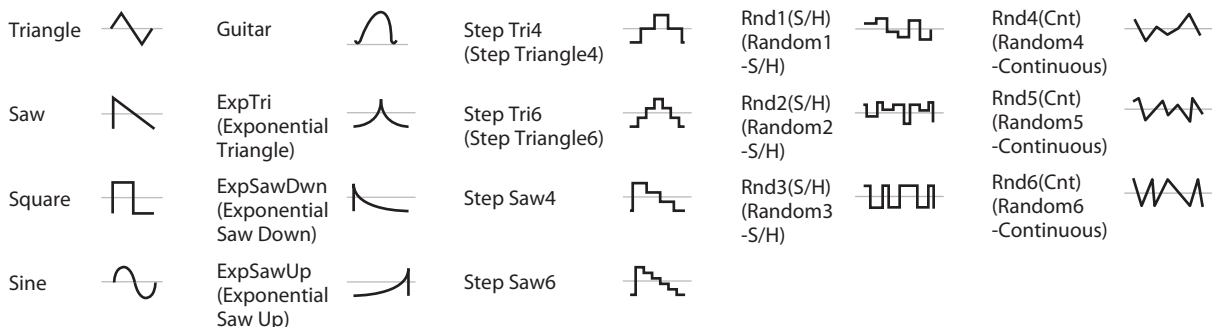

LFO1, LFO2

Waveform [Triangle...Random6 (Continuous)]

This selects the basic LFO waveform, as shown in the graphic below.

Most of the waveforms should be self-explanatory, but a few will benefit from more details:

Guitar is intended for guitar vibrato, and its shape is specifically tuned for this purpose. The waveform is positive-only, so that when used for pitch, it will bend up, and not down.

Random1 (S/H) generates traditional sample and hold waveforms, in which the level changes randomly at fixed intervals of time.

Random2 (S/H) randomizes both the levels and the timing.

Random3 (S/H) generates a pulse wave with random timing. It’s the opposite of traditional sample and hold; the timing varies, but the levels don’t.

Random4–6 (Continuous) are smoothed versions of Random 1–3, with ramps instead of steps. You can use them to create more gentle random variations.

Frequency [00...99]

This controls the speed of the LFO, before any modulation. Higher values mean faster speeds, as shown in the table below.

By using AMS modulation, you can also get speeds much faster and much slower than are available through this basic setting.

Frequency Value	Frequency in Hz
00	0.014 Hz
10	0.112 Hz
20	0.422 Hz
30	0.979 Hz
40	1.79 Hz
50	2.84 Hz
60	4.14 Hz
70	5.69 Hz
80	7.49 Hz
90	9.53 Hz
99	26.25 Hz
99 + Fine 99	32 Hz

Start Phase [-180...+180, Random]

This controls the phase of the waveform at the start of the note, in steps of 5 degrees.

If "Key Sync" is Off, the Start Phase will apply only to the first note of the phrase.

Shape [-99...+99]

Shape adds curvature to the basic waveform. As you can see in the graphic below, this can make the waveforms either more rounded or more extreme. It can also be useful to emphasize certain value ranges, and de-emphasize others.

For example, let's say that you are using a triangle LFO to modulate filter cutoff. If Shape emphasizes the high value range, the filter will spend more time at the higher frequencies. If it emphasizes the low range, the filter will spend more time at the lower frequencies.

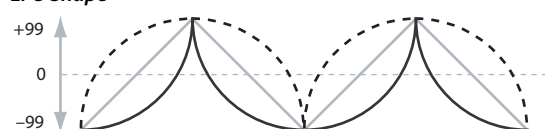
LFO Shape

- Shape = 0 (original waveform)
- - - Shape = +99
- Shape = -99

Note: Shape does not affect the Square and Random3 waveforms, since their values are always either +99 or -99. When these are selected, Shape is grayed out.

OSC 2**LFO1, LFO2**

Here you can specify the LFO1 and LFO2 waveforms for oscillator 2.

The parameters are the same as the LFO1 and LFO2 settings for oscillator 1 (☞ "OSC 1" on page 116).

Waveform [Triangle...Random6 (Continuous)]

This selects the basic LFO waveform.

☞ "Waveform" on page 116

Frequency [00...99]

This controls the speed of the LFO, before any modulation.

☞ "Frequency" on page 117

Start Phase [-180...+180, Random]

This controls the phase of the waveform at the start of the note, in steps of 5 degrees.

☞ "Start Phase" on page 117

Shape [-99...+99]

Shape adds curvature to the basic waveform.

☞ "Shape" on page 117

Common

This is a single, Common LFO, global for all voices in the Program—like the modulation LFOs in some vintage analog synths.

Waveform [Triangle...Random6 (Continuous)]

This selects the basic LFO waveform.

☞ "Waveform" on page 116

Frequency [00...99]

This controls the speed of the LFO, before any modulation.

☞ "Frequency" on page 117

Start Phase [-180...+180, Random]

The Reset AMS, described above, lets you reset the Common LFO. This is the phase from which the LFO will start when it is reset.

Shape [-99...+99]

Shape adds curvature to the basic waveform.

☞ "Shape" on page 117

OSC1 LFO1 AMS Source

This page has all of the controls for the first LFO of Oscillator 1. For instance, you can:

- Control the LFO's frequency, and assign AMS controllers to modulate the frequency.
- Use the "Key Sync" parameter to choose whether the LFO runs separately for each voice, or is synchronized across all of the voices
- Use the "Fade" and "Delay" parameters to control how long the LFO waits to start after note-on, and whether it starts abruptly or fades in slowly.
- Set the LFO to sync to MIDI tempo.

OSC 1 LFO 1

Shape AMS Src [List of AMS Sources]

This selects an AMS source for controlling the LFO's Shape. Modulating the shape can dramatically alter the effect of the LFO—try it out!

For a list of AMS sources, please see "Alternate Modulation Source (AMS)" on page 287.

Shape AMS Int [-99...+99]

This controls the depth and direction of the AMS (Shape) modulation.

Stop [Off, On]

On: Instead of the LFO functioning normally, it will ignore the Freq setting. The LFO will maintain the initial value (determined by the combination of Waveform, Phase, Shape, and Offset) until the note-off.

Since the value will change only at note-on, using a Random waveform will produce a fixed value that changes randomly at each note-on (or at the first note-on).

Off: The LFO will function normally.

Key Sync. [Off, On]

On: When Key Sync is On, the LFO starts each time you press a key, and an independent LFO runs for each note. This is the normal setting.

Off: When Key Sync is Off, the LFO starts from the phase that's determined by the first note in the phrase, so that the LFOs for all notes being held are synchronized together. The Fade and Delay settings will only apply to the first note's LFO.

Note that even if Key Sync is Off, each note's LFO speed may still be different if you modulate the Frequency by note number, velocity, key scaling, or other note-specific AMS sources.

Offset [-99...+99]

By default, almost all of the LFO waveforms are centered around 0, and then swing all the way from -99 to +99. This parameter lets you shift the LFO up and down, so that—for instance—it's centered on 50, and then swings from -49 to +149.

For example, let's say that you're using an LFO for vibrato. If the Offset is 0, the vibrato will be centered on the note's original pitch, bending it both up and down.

If the Offset is +99, on the other hand, the vibrato will only raise the pitch above the original note.

Offset settings and pitch change produced by vibrato

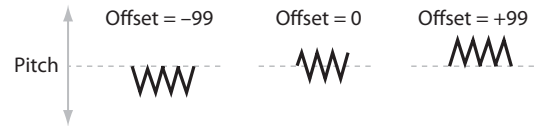

The one exception to this is the Guitar waveform, which is designed to emulate bending a string on a guitar—so that the pitch only goes up, and not down. Because of this, the waveform is centered on 50, and not on 0. Of course, you can always use a negative Offset to shift it back down below 0 again!

Since Offset affects the output values of the LFO, it's important to note that it affects the signal after the Shape function, as shown below:

How the LFO signal is affected by Shape and Offset

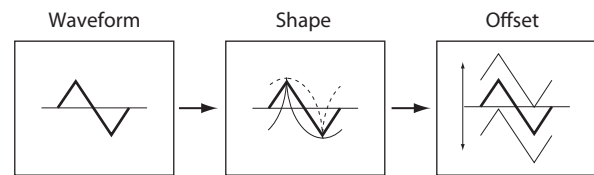

Fade [00...99]

The LFO can fade in gradually, instead of simply starting immediately at full strength. This parameter specifies the time from when the LFO begins to play until it reaches its maximum amplitude.

If the Delay parameter is being used, then the fade will begin after the delay is complete.

When Key Sync is Off, the fade will apply only to the first note in the phrase.

LFO Fade and Delay

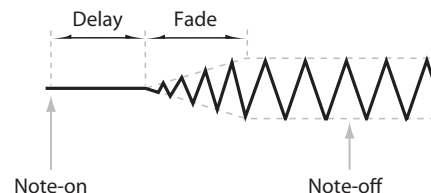

Delay [00...99]

This sets the time from note-on until the LFO starts.

When "Key Sync" is Off, the delay applies only to the first note of the phrase.

Frequency Modulation

You can use two alternate modulation sources (AMS) to adjust the speed of the LFO.

AMS1:

Source [List of AMS Sources]

This selects the first AMS source for the LFO1's frequency. For a list of AMS sources, please see "Alternate Modulation Source (AMS)" on page 287.

Note that you can use LFO2 to modulate LFO1's frequency.

Intensity [-99...+99]

This sets the initial amount of AMS1 (Frequency). The Int Mod AMS then adds to this initial amount.

When AMS is at its maximum value (for example by moving the joystick fully away from yourself), the AMS affects the frequency as shown below:

Intensity	Change to LFO Frequency	
+99	64x	Faster
+82	32x	
+66	16x	
+49	8x	
+33	4x	
+16	2x	
-16	1/2x	Slower
-33	1/4x	
-49	1/8x	
-66	1/16x	
-82	1/32x	
-99	1/64x	

IntMod Src (Intensity Mod AMS)

[List of AMS Sources]

This selects a secondary AMS source to scale the intensity of AMS1.

For a list of AMS sources, please see “Alternate Modulation Source (AMS)” on page 287.

IntMod Int [-99...+99]

This controls the depth and direction of the “Int Mod Src.” Even if the main AMS1 “Intensity” is set to 0, “Int Mod Src” can still control the final amount of AMS A over the full +/-99 range.

For example, if “Source” is set to the Pitch EG, and “Int Mod Src” is set to JS+Y:CC#01, positive settings mean that YS+Y will increase the intensity of the Pitch EG modulation of the LFO Frequency.

AMS2:

Source [List of AMS Sources]

This selects the second AMS source for the LFO1’s frequency.

For a list of AMS sources, please see “Alternate Modulation Source (AMS)” on page 287.

Intensity [-99...+99]

This controls the amount of modulation from “Source.”

Frequency MIDI/Tempo Sync.

MIDI/Tempo Sync. [Off, On]

When “MIDI/Tempo Sync” is On, the LFO will synchronize to the system tempo, as set by either the Tempo or MIDI Clock. The LFO speed will be controlled by the “Base Note” and “Times” parameters, below. All settings for “Frequency” and Frequency Modulation will be ignored.

When “MIDI/Tempo Sync” is Off, the “Frequency” and Frequency Modulation settings will determine the speed of the LFO, and the tempo settings will have no effect.

Base Note [♩..o.]

This sets the basic speed of the LFO, relative to the system tempo. The values range from a 32nd note to a whole note, including triplets.

Times [01...32]

This multiplies the length of the Base Note. For instance, if the “Base Note” is set to a sixteenth note, and “Times” is set to 03, the LFO will cycle over a dotted eighth note.

OSC1 LFO2 AMSource

This is Oscillator 1’s second LFO. Its parameters are exactly the same as those for the first LFO—except that LFO1 cannot modulate LFO2.

☞ “OSC1 LFO1” on page 118

OSC2 LFO1 AMSource

This page controls Oscillator 2’s first LFO. It is available only when the Oscillator Mode is set to Double; if not, the page will be grayed out.

The parameters are identical to those for Oscillator 1.

☞ “OSC1 LFO1” on page 118

OSC2 LFO2 AMSource

This page controls Oscillator 2’s second LFO. It is available only when the Oscillator Mode is set to Double; if not, the page will be grayed out.

Its parameters are exactly the same as those for the first LFO—except that LFO1 cannot modulate LFO2.

☞ “OSC1 LFO1” on page 118

Common LFO AMSSource

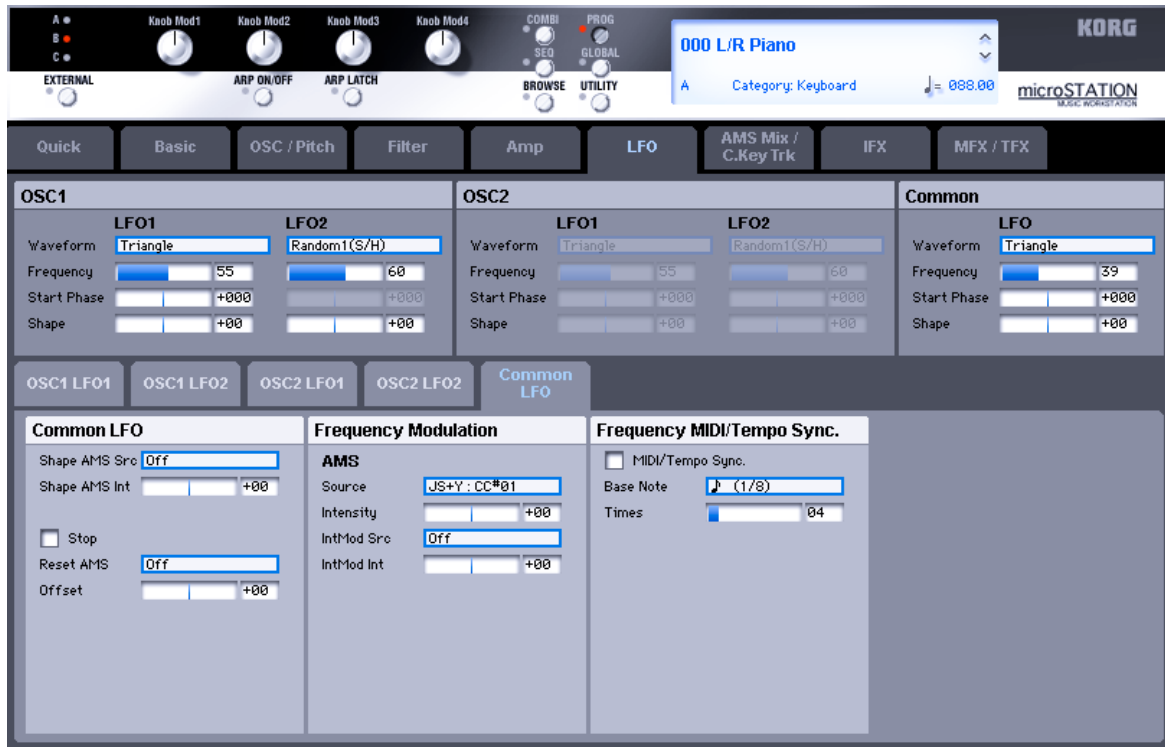

Differences from LFO1/2

The Common LFO starts running as soon as you select the Program, and only resets when you tell it to do so explicitly via the Reset Source control, below. This is different from LFO1/2's "Key Sync" parameter, which resets whenever all notes are released.

The Common LFO's persistence can be handy if you want to create a constant rhythm with an LFO, and then play "underneath" that rhythm without re-triggering it. For instance, you can use a MIDI controller in your sequencer to reset the Common LFO every few bars, regardless of what notes are being played.

The Common LFO has most of the same controls as LFO1/2. However, it does not include the "Delay," "Fade," and "Key Sync" settings, since these only make sense for per-voice LFOs.

Common LFO

Shape AMS Src [List of AMS Sources]

This selects an AMS source for controlling the LFO's Shape. Modulating the shape can dramatically alter the effect of the LFO—try it out!

For a list of AMS sources, please see "Alternate Modulation Source (AMS)" on page 287.

Shape AMS Int [–99...+99]

This controls the depth and direction of the AMS (Shape) modulation.

Stop [Off, On]

On: Instead of the LFO functioning normally, it will ignore the Freq setting. Instead, the LFO simply generates a single value when the Program is selected, and then holds that value until you select another Program, or until you reset the LFO via AMS.

Note: This is different from LFO1/2, in which the value is reset with every note-on.

You can use this in conjunction with the Random waveforms to create static, random modulation, with the value changing only when you first select the Program.

Off: When Stop is Off, the LFO will function normally.

Reset AMS [List of AMS Sources]

This selects an AMS source to reset the LFO to the Start Phase. The LFO resets when the AMS value passes the halfway mark: +50 for most AMS sources, or 64 for MIDI controllers.

To create an effect similar to the per-voice LFOs' "Key Sync." setting, set this to Gate 2+ Damper.

Offset [–99...+99]

By default, almost all of the LFO waveforms are centered around 0, and then swing all the way from –99 to +99. This parameter lets you shift the LFO up and down, so that—for instance—it's centered on 50, and then swings from –49 to +149.

For a complete description, please see the entry under LFO1 ("Offset" on page 118).

Frequency Modulation

These parameters are identical to the Frequency Modulation settings for LFO1.

☞ "Frequency Modulation" on page 118.

Frequency MIDI/Tempo Sync

These parameters are identical to the Frequency MIDI/Tempo Sync for LFO1.

☞ "Frequency MIDI/Tempo Sync." on page 119.

AMS Mix/C.KeyTrk (AMS Mixer/Common Keyboard Track)

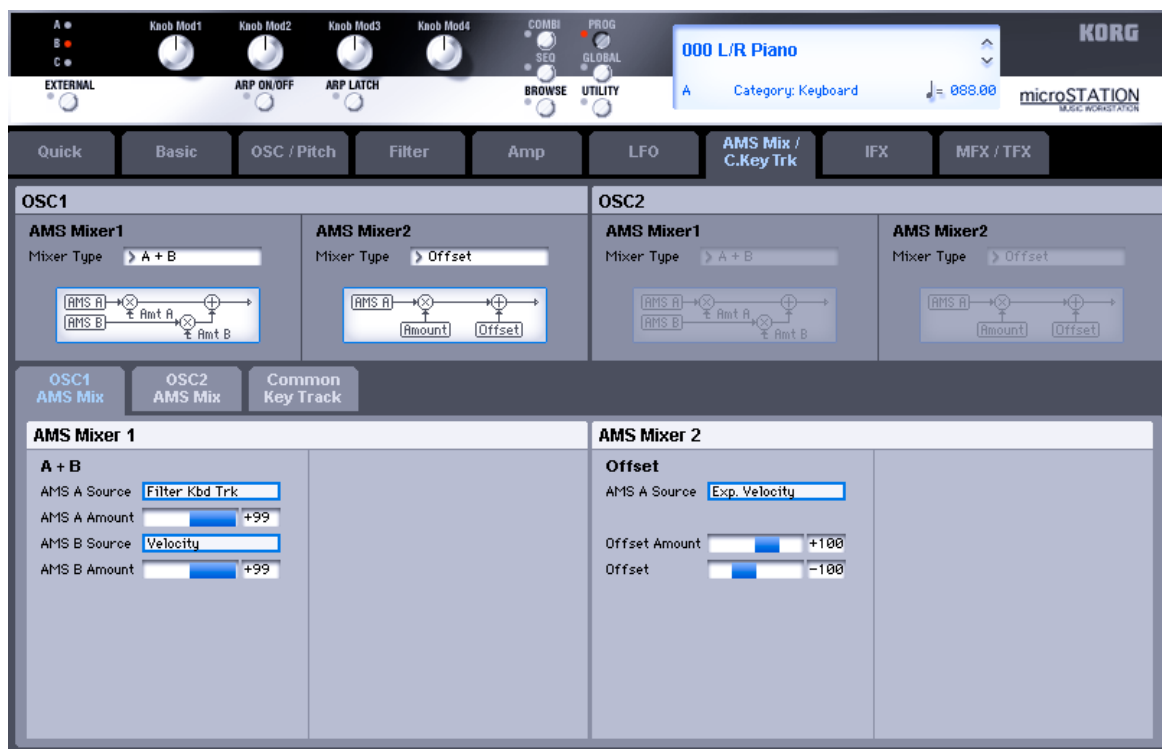

Each Oscillator has two AMS Mixers, which are simple but powerful tools for combining and modifying AMS signals. The two Oscillators also share two Common keyboard tracking generators, in addition to the dedicated keyboard tracking for the Filter and Amp.

These pages let you control all of these modulation sources. Note that when the Oscillator Mode is set to Single, only Oscillator 1's AMS Mixers are active; the pages for Oscillator 2 will be grayed out.

OSC1

The AMS Mixers combine two AMS sources into one, or process an AMS source to make it into something new. For instance, they can add two AMS sources together, or use one AMS source to scale the amount of another. You can also use them to change the shapes of LFOs and EGs in various ways, modify the response of realtime controllers, and more.

You can select the output of the AMS mixers as an AMS source in the same way as an LFO or EQ. This also means that the original, unmodified inputs to the AMS Mixers are still available as well. For instance, if you use LFO1 as an input to an AMS Mixer, you can use the processed version of the LFO to control one AMS destination, and the original version to control another. Finally, you can cascade the two AMS Mixers together, by using AMS Mixer 1 as an input to AMS Mixer 2.

AMS Mixer1:

Mixer Type [A+B, Amt Ax B, Offset, Smoothing, Shape, Quantize, Gate Control]

This controls the type of processing performed by AMS Mixer 1. Each of the Mixer Types is discussed in detail over the next several pages.

A+B adds two AMS sources together. For more information, please see "A+B:" on page 122..

Amt Ax B scales the amount of one AMS source with the other. For more information, please see "Amt Ax B:" on page 122.

Offset adds or subtracts a constant value to or from an AMS source. For more information, please see "Offset:" on page 123.

Smoothing specifies the smoothness of movement between two values. You can use this to smooth sudden changes such as an abrupt movement of the joystick or sharp angle of the LFO. For more information, please see "Smoothing:" on page 123.

Shape adds curvature to the AMS input. For more information, please see "Shape:" on page 123.

Quantize turns smooth transitions into discrete steps. For more information, please see "Quantize:" on page 124.

Gate Control uses a third AMS source to switch between two AMS inputs (or a fixed value). For more information, please see "Gate Control:" on page 125.

AMS Mixer2:

Mixer Type [A+B, Amt Ax B, Offset, Smoothing, Shape, Quantize, Gate Control]

This is the second AMS Mixer for Oscillator 1. The parameters are exactly the same as those for AMS Mixer 1.

☞ "AMS Mixer1:" on page 121.

OSC 2

This page controls the two AMS Mixers for Oscillator 2. These are available only when the Oscillator Mode is set to Double; if not, the page will be grayed out. The parameters are identical to those for Oscillator 1. [↩ "OSC1" on page 121](#)

OSC1 AMS Mix AMSource

AMS Mixer1

A+B:

AMS Mixer, Type = A+B

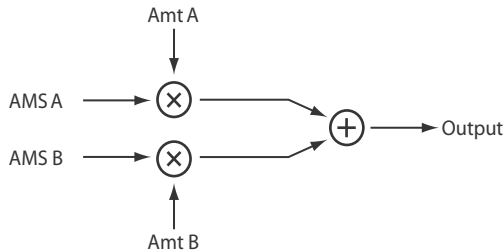

A+B merges two AMS sources into one. This can be handy when you need to add one more modulation source to a parameter, but you've already used up all of the available AMS slots.

For instance, let's say that you're using an LFO to modulate Filter Resonance, and then you decide that it would be interesting to scale that parameter with an EG as well. Resonance has only a single AMS input, but you can easily merge the LFO and the EG together using the A+B AMS Mixer:

1. Assign the LFO to AMS A.
2. Assign the EG to AMS B.
3. Assign the AMS Mixer as the Filter Resonance AMS source.

AMS Mixer A+B example

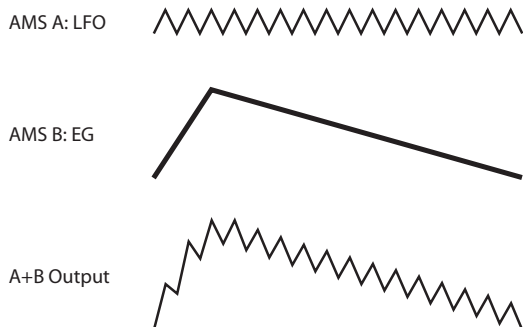

AMS A Source [List of AMS Sources]

This selects the first AMS input. For a list of AMS sources, "Alternate Modulation Source (AMS)" on page 287.

AMS A Amount [-99...+99]

This controls the depth and direction of the AMS A input.

AMS B Source [List of AMS Sources]

This selects the second AMS input.

For a list of AMS sources, "Alternate Modulation Source (AMS)" on page 287.

AMS B Amount [-99...+99]

This controls the depth and direction of the AMS B input.

Amt AxB:

AMS Mixer, Type = Amt A x B

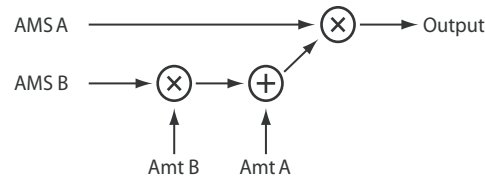

This Mixer Type uses AMS B to scale the amount of AMS A. For instance, you can control the amount of LFO1 with the Filter EG, or control the amount of the Pitch EG with the joystick.

AMS Mixer Amt AxB example

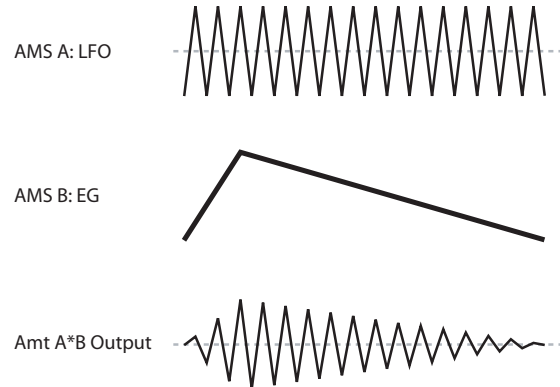

AMS A Source [List of AMS Sources]

This selects the first AMS source, which can then be scaled by AMS B.

For a list of AMS sources, "Alternate Modulation Source (AMS)" on page 287.

AMS A Amount [-99...+99]

This controls the initial amount of AMS A, before modulation from AMS B. Input from AMS B then adds to this initial amount.

Even if Amount A is set to 0, AMS B can still control the final amount of AMS A over the full +/-99 range.

AMS B Source [List of AMS Sources]

This selects the second AMS source, to scale the amount of AMS A.

For a list of AMS sources, "Alternate Modulation Source (AMS)" on page 287.

AMS B Amount [-99...+99]

This controls the depth and direction of the AMS B modulation of AMS A.

For example, if AMS A is set to LFO1 and AMS B is set to the Filter EG, positive settings mean that the EG will increase the amount of LFO1.

Tips: Using a foot switch to turn an AMS source on/off

You can use Amt AxB as a gate control for an AMS source. (You'll need to connect a foot switch, set Global: Controllers "Type SW/Pedal" to Switch, and set "Foot SW Function" to

Foot Switch (CC#82) before you continue with the following procedure.)

1. Assign "AMS A" to a desired source, and set "AMS A Amount" to 0.
2. Assign "AMS B Source" to Foot Switch (CC#82), and set "AMS B Amount" to +99.

Now you can use the foot switch connected to the micro-STATION to turn AMS A on/off.

Offset:

AMS Mixer, Type = Offset

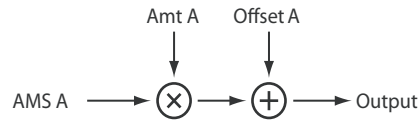

This simple processor adds a constant offset to the input, and also allows you to double the gain of an AMS source. For instance, you can use this to convert a bipolar LFO (both negative and positive) to a unipolar LFO (positive only). To do this:

1. Select the LFO as the AMS A input.
2. Set the AMS A Amount to 50. This cuts the overall level of the LFO in half, so that instead of swinging between -99 and +99, it only swings between -50 and +50.
3. Set the AMS A Offset to 50. This adds 50 to the LFO level, so that it now swings between 0 and +99, as shown below.

AMS Mixer Offset examples

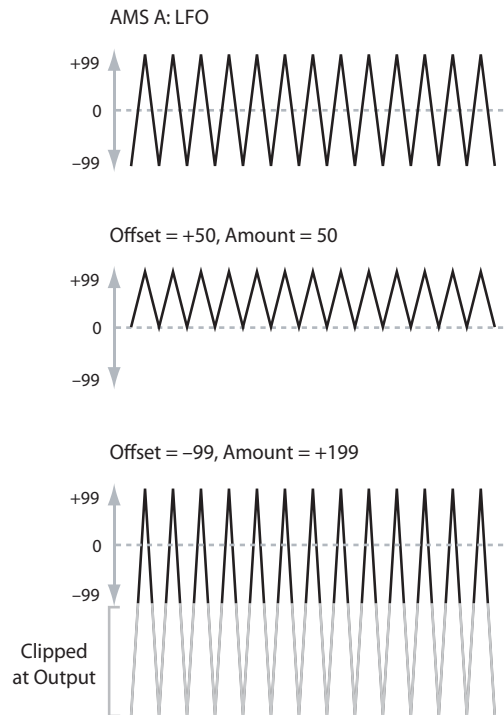

AMS A Source [List of AMS Sources]

This selects the AMS source to be offset. For a list of AMS sources, "Alternate Modulation Source (AMS)" on page 287.

Offset Amount [-199...+199]

This controls the basic level of AMS A. +199 doubles the original signal level, while -199 doubles the level and inverts the phase. The values are clipped only

at the output; internally, they can be greater than the normal range of -99 to +99.

Offset [-199...+199]

This controls the amount of offset for AMS A. Setting Offset to +199 shifts an AMS input of -99 all the way to +99. In conjunction with high AMS A Amount values, this can be useful for creating clipped shapes, such as shown in the last of the "AMS Mixer Offset examples," above.

Smoothing:

This Mixer Type smooths out the AMS input, creating more gentle transitions between values. You have separate control of the amount of smoothing during the attack (when the signal is increasing) and decay (when it's decreasing).

The higher the Attack and Decay settings, the more the input will be smoothed.

Low settings provide subtle controller smoothing, creating more gradual aftertouch, for instance. Higher settings create auto-fade effects, transforming a quick gesture into a longer fade-in and/or fade-out event.

Smoothing can also be used to alter the shape of programmable mod sources, such as LFOs and EGs. For instance, you can turn a "blip" into a simple envelope shape, as shown below.

AMS Mixer Smoothing examples

Original AMS A: Smoothing with Long Attack and Short Release:



Smoothing with Short Attack & Long Release:



AMS A Source [List of AMS Sources]

This selects the AMS source to be smoothed. For a list of AMS sources, "Alternate Modulation Source (AMS)" on page 287.

Attack [00...+99]

This controls the attack time of the smoother, or how long it takes the smoother to reach a new, higher value. Higher Attack settings mean longer times.

Depending on how quickly the AMS input value is changing, high Attack settings may mean that the value is never quite reached, as shown in "AMS Mixer Shape examples," above.

Decay [00...+99]

This controls the decay time of the smoother, or how long it takes the smoother to reach a new, lower value. Higher Decay settings mean longer times.

Shape:

This Mixer Type adds curvature to the AMS input. This applies deformation to the AMS input. You can use this to customize a controller curve, such as the exponential curve of the joystick or the logarithmic curve of velocity control. It can also alter the shape of programmable modulation sources, such as EGs and LFOs.

Note: Shape only affects AMS signals which already have some amount of slope, such as EGs, triangle and sine LFOs, and so on. It does not affect signals which only contain abrupt transitions, such as square waves.

AMS A Source [List of AMS Sources]

This selects the AMS input source to be shaped. For a list of AMS sources, "Alternate Modulation Source (AMS)" on page 287.

Shape [-99...+99]

This controls the amount of curvature, and whether the curves are concave or convex. As you can see in the graphic examples, the shape will tend to emphasize certain value ranges, and de-emphasize others.

For example, let's say that you are using a triangle LFO, through Shape, to modulate filter cutoff. If Shape emphasizes the high value range, the filter will spend more time at the higher frequencies. If it emphasizes the low range, the filter will spend more time at the lower frequencies.

Mode [Symmetric, Asymmetric]

This selects whether the Shape parameter will produce one or two curves. The graphic "AMS Mixer Shape examples" may help to visualize how this works.

Asymmetric will produce a single curve, extending from -99 to +99.

Symmetric will produce two matching curves extending outwards from 0 to -99 and +99, respectively.

Bipolar and Unipolar AMS sources

To understand Shape, it helps to understand the difference between bipolar and unipolar AMS sources.

Bipolar sources can swing all the way from -99 to +99, with 0 in the middle. Most LFOs are bipolar, for instance; so is Pitch Bend.

Generally, bipolar AMS sources will work better with the Asymmetric mode, but Symmetric may also produce interesting results.

Unipolar sources only go from 0 to 99, with 50 in the middle. MIDI controllers, such as JS+Y (CC#1), are all unipolar. In practice, EGs are usually programmed to be unipolar, even though the Filter and Pitch EGs do allow both positive and negative levels.

With unipolar sources, it's almost always better to use the Symmetric mode. The Asymmetric mode can cause offsets and other strange results.

AMS Mixer Shape examples

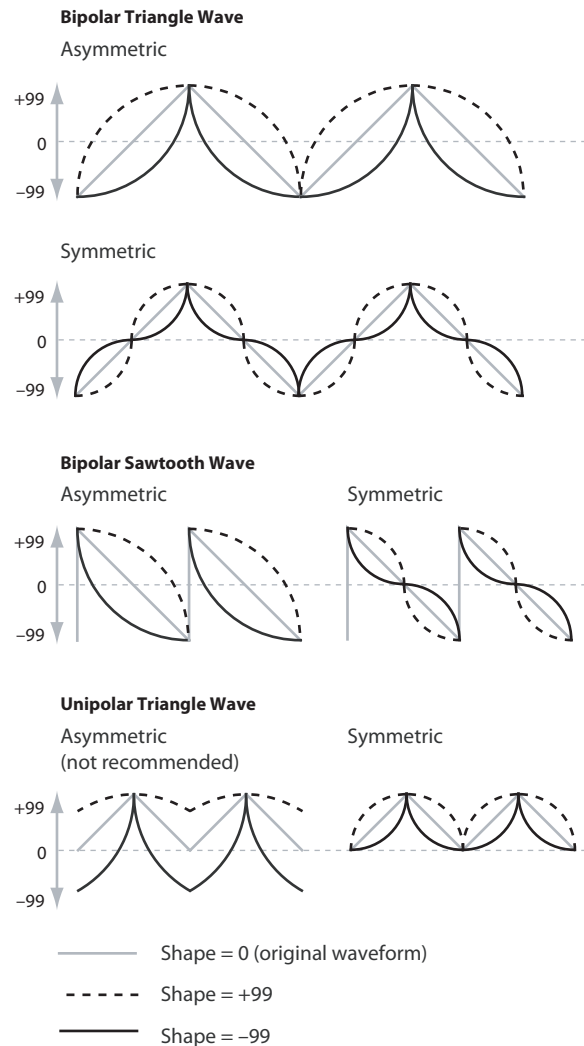

Quantize:

This Mixer Type changes the input from a continuous signal into a series of discrete steps. Instead of moving smoothly between values, it will snap immediately from one value to another.

You can use this to change the shape of LFOs or EGs, or to force a controller to land on a few specific values.

AMS Mixer Quantize examples

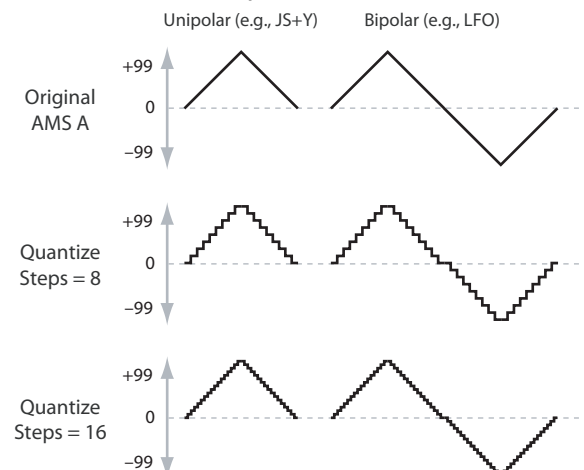

AMS A Source

[List of AMS Sources]

This selects the AMS input source to be quantized. For a list of AMS sources, “Alternate Modulation Source (AMS)” on page 287.

Steps

[2...32]

This controls the severity of the effect. The lower the number of steps, the more “steppy” the output will be. For instance, when this is set to 2, there will be “steps” at 0, 50, and 99. With a bipolar AMS input, there will also be steps at -50 and -99. As another example, when it is set to 5, there will be steps at 0, 20, 40, 60, 80, and 99 (as well as -20, -40, -60, -80, and -99 for bipolar inputs).

Tip: Quantized Joystick Pitch Bend

You can use the joystick to create quantized pitch bends that simulate sliding across the frets of a guitar, or jump-bend sounds caused by differences in the length of the tube of a trumpet. To do so:

1. Select the AMS Mixer as the Oscillator Pitch AMS input.
2. Set the Pitch AMS Intensity to any exact half-step value, such as +5.00, +7.00, etc.
3. Set the JS(+X), JS(-X) amount to 0.00.
4. In the AMS Mixer, select the JS X as AMS A.
5. Set the Number Of Steps to the same number you used in Step 2.

Now, playing the joystick will create quantized pitch bends. JSX will still produce smooth pitch bends, as usual, so you can use both techniques together.

Gate Control:

AMS Mixer, Type = Gate Control

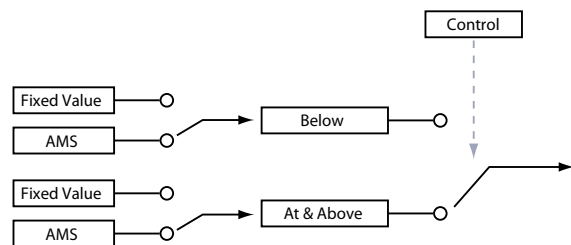

This Mixer Type lets you set up two different AMS sources (or fixed AMS amounts), and then switch between the two using a third AMS source.

It’s similar to an audio gate with a side-chain, but with even more flexibility—since you get to choose what happens when the gate is closed (below the threshold), as well as when it’s open (above the threshold).

You can also choose whether the gate will be able to open and close continuously in response to the control source, or whether it only opens or closes at the beginning of the note, and then stays that way over the note’s entire duration.

You can use the Gate to:

- Use a foot-switch (or other controller) to apply pitch-bend or other effects to some notes, but not to others
- The parameter will be applied when the controller reaches a specific threshold. For example, the velocity value could control the filter resonance only if the velocity value exceeds 90.
- Use the joystick, switches, or controllers to change between two separate LFOs (or other AMS sources).

Gate Output:

If the value of the Control Source is less than the “Threshold,” the Gate outputs the preset value or AMS source selected under “Below Threshold.”

If the value of the Control “Source” is greater than or equal to the “Threshold,” the Gate outputs the preset value or AMS source selected in the At & Above Threshold parameter.

Below Thresh.

[Fixed Value, AMS A]

This selects whether Below Threshold uses a preset value, or the selected AMS source.

Fixed Value

[-99...+99]

This lets you set a specific value to be used when the Control Source is less than the Threshold. This only applies when Below Threshold is set to Fixed Value.

AMS Source

[List of AMS Sources]

This lets you set an AMS source to pass through the Gate when the Control Source is less than the Threshold. This only applies when Below Threshold is set to AMS A.

At & Above Thresh.

[Fixed Value, AMS B]

This selects whether At & Above Threshold uses a preset value, or the selected AMS source.

Fixed Value

[-99...+99]

This lets you set a specific value to be used when the Control Source is greater than or equal to the Threshold. This only applies when At & Above Threshold is set to Fixed Value.

AMS Source

[List of AMS Sources]

This lets you set an AMS source to pass through the Gate when the Control Source is greater than or equal to the Threshold. This only applies when At & Above Threshold is set to AMS B.

Gate Control:

Source

[List of AMS Sources]

This selects the AMS source to control the gate.

Control At Note-On Only

[Off, On]

When this is enabled (On), the value of the Control “Source” at note-on will select the output (Below Threshold or At & Above Threshold). The selected output will then remain active throughout the duration of the note, regardless of any subsequent change in the Control Source’s value.

Note that the output value itself can continue to change; only the selection of Below or At & Above is fixed.

Threshold

[-99...+99]

This sets the value of the Control “Source” where the gate opens or closes.

Tips: Examples of using Gate

Using a foot switch to apply pitch bend to specific notes

By using “Control At Note-On Only,” you can apply an effect only to a specific note-on. For example:

1. Set Gate Control “Source” to Foot SW: #82. (You’ll need to connect a foot switch, set Global: Controllers “Type SW/Pedal” to Switch, and set “Foot SW Function” to Foot Switch (CC#82) before you continue with the following procedure.)
2. Set “Control At Note-On Only” to On.
3. Set the Threshold to 50.

4. Set Below Threshold to a Fixed Value of +00.
5. Set At & Above Threshold to AMS B: JS X.
6. On the OSC Pitch page, assign the AMS Mixer to control the pitch.
7. Turn off the foot switch, and while holding down a chord, move the joystick in the X-direction. The pitch will not change.
(If the pitch changes, go to the OSC Pitch page and set Pitch "JS (+X) and "JS (-X)" to +00.)
8. Turn on the foot switch, and add a new note to the previous chord.
9. Move the joystick in the X-direction; pitch bend will be applied only to the newly-played note.

The new note will bend, but the original chord (played before you pressed on the foot-switch) will not.

Selective pitch-bend, using only the joystick

You can also use a single AMS source as both the Control Source and a value source:

1. Set the Control Source to JS X.
2. Set Control At Note-On Only to On (checked).
3. Set the Threshold to 00.
4. Set Below Threshold to AMS A: JS X.
5. Set At & Above Threshold to a Fixed Value of 00.
6. On the OSC Pitch page, assign the AMS Mixer to control the pitch.
7. With the joystick in the center, play a chord, and hold it through step 9.
8. Bend the joystick to the left, and then play a new note above the chord.
(If the pitch changes, go to the OSC Pitch page and set Pitch "JS (+X) and "JS (-X)" to +00.)

Use the joystick to bend the pitch of the new note.

The new note will bend, but the original chord (played before you bent the joystick down) will not. This method is particularly good for bending the top note of a chord up to pitch.

Generating a static value

Sometimes, it can be handy to have a preset value as an AMS source. The Gate is one way to create this. To do so:

1. Set both Below Threshold and At & Above Threshold to Fixed Value, and enter the same value into each.

Now, the AMS mixer will always generate this static value.

AMS Mixer 2 AMSource

This is the second AMS Mixer for Oscillator 1. The parameters are exactly the same as those for AMS Mixer 1.

☞ "AMS Mixer1" on page 122.

OSC 2 AMS Mix AMSource

This page controls the two AMS Mixers for Oscillator 2. These are available only when the Oscillator Mode is set to Double; if not, the page will be grayed out.

The parameters are identical to those for Oscillator 1.

☞ "OSC1 AMS Mix" on page 122

Common KeyTrack (Common Keyboard Track)

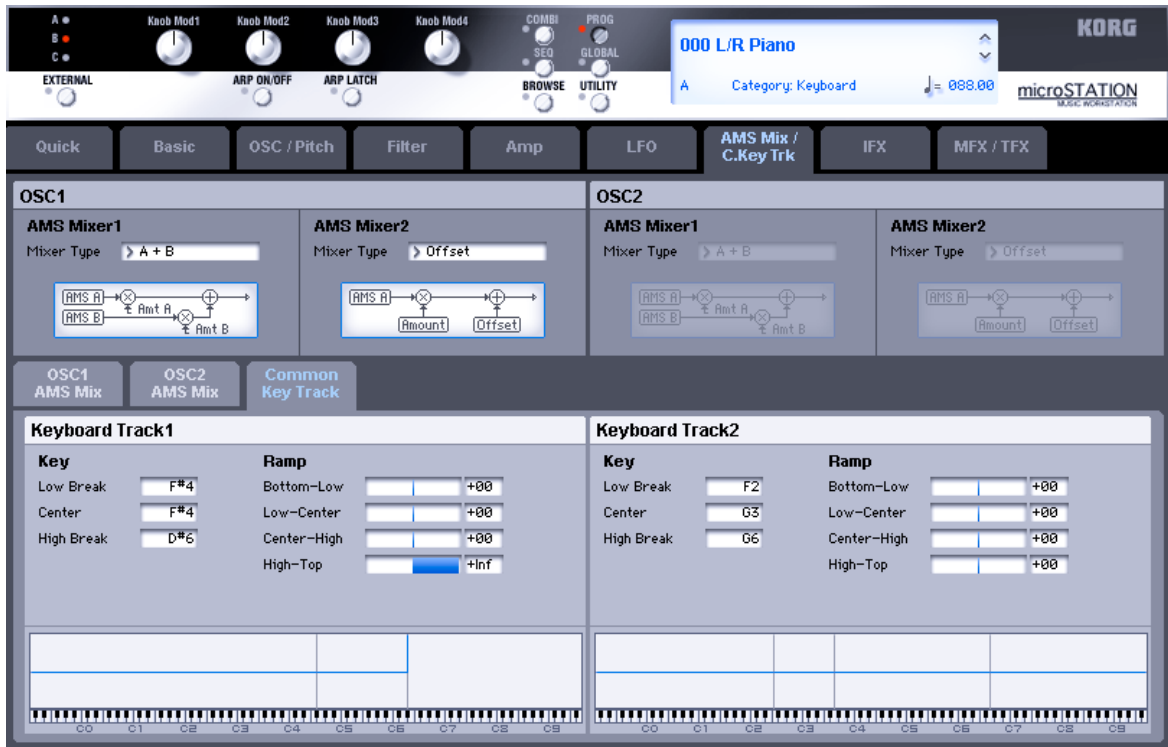

The two Oscillators share two Common keyboard tracking generators, in addition to each Oscillator's dedicated keyboard tracking for the Filter and Amp. You can use these Common keytracks as AMS sources for modulating most AMS destinations.

The Common Keyboard Track parameters are shared by the entire Program, but the actual AMS values are calculated individually for each voice.

What does Keyboard Tracking do?

At its most basic, keyboard tracking lets you vary the modulation amount as you play up and down the keyboard. This can be useful for making the timbre consistent across the entire range, or adjusting parameters according to pitch.

The microSTATION keyboard tracking can be fairly complex, if desired. You can create different rates of change over up to four different parts of the keyboard. For instance, you can:

- Make the modulation increase very quickly over the middle of the keyboard, and then increase more slowly—or not at all—in the higher octaves.
- Make the modulation increase as you play lower on the keyboard.
- Create abrupt changes at certain keys, for split-like effects.

Common Keyboard Tracking

At the Center Key, the AMS value is always 0.

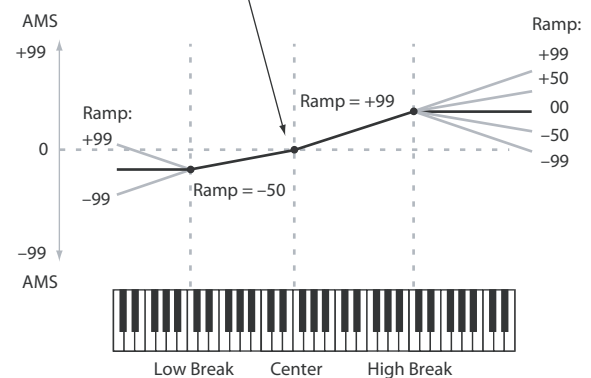

How it works: Keys and Ramps

The keyboard tracking works by creating four ramps, or slopes, between five keys on the keyboard.

☞ "Break Key" on page 102

Keyboard Track 1 AMSsource

Key

Low Break

[C-1...G9]

This specifies the note that will be the break point connecting the two sloped lines in the low region.

Center

[C-1...G9]

This specifies the note that will be the break point in the center of keyboard tracking. At this key, the keyboard tracking has no effect on the AMS destinations.

High Break [C-1...G9]

This specifies the note that will be the break point connecting the two sloped lines in the high region.

Ramp:

See "Ramp:" on page 103.

Bottom-Low [-Inf, -99...+99, +Inf]

This sets the slope between the bottom of the MIDI note range and the Low Break key. For normal key track, use negative values.

Low-Center [-Inf, -99...+99, +Inf]

This sets the slope between the Low Break and Center keys. For normal key track, use negative values.

Center-High [-Inf, -99...+99, +Inf]

This sets the slope between the Center and High Break keys. For normal key track, use positive values.

High-Top [-Inf, -99...+99, +Inf]

This sets the slope between the High Break key and the top of the MIDI note range. For normal key track, use positive values.

The table below shows how the Ramps affect the AMS output:

Ramp value	AMS change
-Inf	goes to -99 in 1 half-step
-99	-20 per octave
-50	-10 per octave
0	no change
+50	+10 per octave
+99	+20 per octave
+Inf	goes to +99 in 1 half-step

+Inf and -Inf ramps

+Inf and -Inf are special settings which create abrupt changes for split-like effects. When a ramp is set to +Inf or -Inf, the keyboard tracking will go to its extreme highest or lowest value over the span of a single key.

+Inf and -Inf Ramps

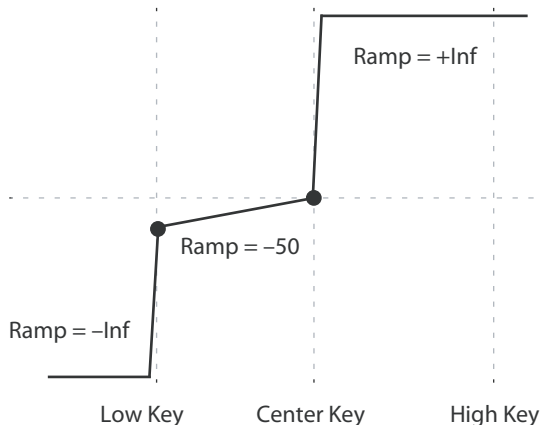

Note: If you set the Center-High ramp to +Inf or -Inf, the High-Top parameter will be grayed out. Similarly, if you set the Low-Center ramp to +Inf or -Inf, the Bottom-Low ramp will be grayed out.

Keyboard Track 2 AMSource

This is the second Common keyboard tracking generator. Its parameters are exactly the same as those for Keyboard Track 1.

☞ "Keyboard Track 1" on page 127

IFX (Insert Effect)



Here, you can adjust settings for the insert effects. For instance, you can:

- Send the output of an oscillator to an insert effect
- Route a sound to an insert effect
- Make detailed settings for insert effects

For more information, please see “Effect Guide” on page 205.

IFX Routing

This graphic shows an overview of the insert effects, including the routing of the oscillators to the effects, the effects names and on/off status, chaining between the effects, and the output bus where the insert effects are themselves routed.

This page lets you adjust the routing of the oscillators to the insert effects.

IFX1 On/Off	[Off, On]
IFX2 On/Off	[Off, On]
IFX3 On/Off	[Off, On]
IFX4 On/Off	[Off, On]
IFX5 On/Off	[Off, On]

Switches the insert effect on/off.

If this is off, the input will simply be passed to the output. (When 000:No Effect is selected, there’s no difference between On and Off.)

The setting will alternate between on and off each time you press the button.

MIDI Separately from this setting, you can use MIDI CC #92 (on the global MIDI Channel (p.184) to turn all insert effects off. A value of 0 turns them off, and values of 1–

127 restore the original setting.

IFX1	[S00...S63, D00...D10]
IFX2	[S00...S61, D00...D09]
IFX3	[S00...S61, D00...D09]
IFX4	[S00...S61, D00...D09]
IFX5	[000...061]

This selects the effect type for insert effect.

IFX5 cannot use double-size effects (D00–D10). If you use a double-size effect, the next insert effect will be unavailable. For example if you select a double-size effect for IFX1, you won’t be able to use IFX2.

OSC MFX Send

OSC1

Send to MFX1	[000...127]
---------------------	-------------

Sets the volume (send level) at which the output of oscillator 1 will be sent to master effect 1. This applies only when “Bus Select” is set to L/R or Off.

If “Bus Select” is set to IFX1–IFX5, the send levels to master effects 1 and 2 are set by IFX Setup page “Send 1” and “Send 2” after passing through IFX1–5.

Send to MFX2	[000...127]
---------------------	-------------

Sets the volume (send level) at which the output of oscillator 1 will be sent to master effect 2. For more information, please see “Send to MFX1” on page 129.

OSC2

Send to MFX1 [000...127]

Send to MFX2 [000...127]

Sets the volume (send level) at which the output of OSC2 will be sent to master effects 1 and 2. These parameters will be valid when “Oscillator Mode” is set to Double (p.82) and “Bus Select” is set to L/R or Off.

MIDI CC#93 controls OSC 1/2’s Send 1 level, and CC#91 controls the Send 2 level. These are controlled on the global MIDI channel “Channel” (p.60). The actual send level is determined by multiplying these values with the send levels of each oscillator.

Use Dkit Setting [Off, On]

This is shown if “Oscillator Mode” (p.82) is set to Drums. If Oscillator Mode is set to Single or Double, this setting is ignored.

On: The “Bus Select,” “FX Control Bus,” “Send 1,” and “Send 2” settings (p.191) for each key of the selected drum kit will be used. Turn on this if you want to apply an individual insert effect to each drum instrument.

Tip: In most preloaded drumkits, the drum instruments have the same “Bus (IFX/Output)” settings according to their type, as follows.

Snares → IFX1

Kicks → IFX2

Other → IFX3

Off: The “Bus Select,” “FX Control Bus,” “Send to MFX1,” “Send to MFX2” settings will be used. All drum instruments will be sent to the specified bus.

Routing

This page lets you adjust the output bus of the oscillators and FX control bus.

Bus Select

Bus Select [L/R, IFX1...IFX5, Off]

This specifies the output bus for oscillators 1 and 2.

L/R: The oscillators will be output to the L/R bus. Normally you will choose L/R.

IFX1...IFX5: Output to the IFX1–5 busses.

Off: The oscillator will not be output from the L/R bus, or IFX1–5 busses. Choose the Off setting if you want the program oscillator output of the timbre to be connected in series to a master effect. Use “Send1 to MFX1” and “Send2 to MFX2” to specify the send levels.

FX Control Bus [Off, 1, 2]

Sends the output of the oscillator 1, 2 to an FX Control bus (two-channel mono FX Ctrl 1 or 2).

Use the FX Control busses when you want a separate sound to control the audio input of an effect. You can use two FX Control busses (each is a two-channel mono bus) to control effects in various ways.

For more information, please see “FX Control Bus” on page 207.

IFX Setup



IFX1

Here, you can choose the type of each insert effect 1, its on/off status, chaining, and adjust the post-IFX mixer settings. For insert effects, the direct sound (Dry) is always stereo-in and out. The input/output configuration of the effect sound (Wet) depends on the effect type.

For more information, please see “In/Out” on page 208.

Chain to [IFX2...IFX5]

You can chain up to five insert effects together in series, to create more complex effects. Set up the chain using this parameter, and then enable it using the “Chain” parameter, below.

Effects must be chained in ascending numeric order. For example, IFX1 can be chained to any of IFX2 through IFX5.

You can chain two or more effects into the same downstream effect. For instance, both IFX1 and IFX2 can be chained to IFX5.

The Pan, Bus, FX Control Bus, and Send1/2 settings apply only to the last effect in the chain. However, any effect in the chain can be sent to the FX Control buses.

Chain [Off, On]

This connects insert effects in series. If “Chain” is On, this insert effect will be connected in series with the insert effect selected by “ChainTo.”

Example: IFX1 “ChainTo”: IFX2

IFX1 “Chain”: On

Insert effects 1 and 2 will be connected in series. If “Bus” is set to IFX1, the oscillator’s output will be sent in series through IFX1 → IFX2. You can connect up to five insert effects (IFX1-IFX5) in series. In this case, the “Pan,” “Bus,” “FxCtrl Bus,” “Send1,” and “Send2” settings following the last insert effect will be used.

Pan [L000...C064...R127]

Specifies the panning immediately after the insert effect.

MIDI You can use CC#8 to control this.

Bus (Bus Select) [Off, L/R]

Specifies the bus where the signal will be sent immediately after the insert effect.

L/R: The signal will be sent to the L/R bus, which passes through TFX and then goes to the OUTPUT L/R outputs. This is the default setting.

Off: The signal will not be sent directly to the L/R outputs. This setting is useful if you want to:

- Use “Send 1” or “Send 2” to route the signal entirely through the master effects, without sending the dry signal to the outputs.
- Use the FX Control Bus to route the signal to an effects side-chain, such as a gate or vocoder, without being heard directly at the outputs.

FX Control Bus [Off, 1, 2]

Sends the post-IFX signal to the FX Control busses.

For more information, please see “FX Control Bus” on page 130.

⚠ If you’re using “FX Control Bus” as an input signal for Vocoder etc., a feedback loop will occur if you output to the same bus as specified here, and oscillation will occur. Set this with care to avoid creating a loop.

Send1 [000...127]

Send2 [000...127]

These adjust the level at which the post-IFX signal is sent to master effects 1 and 2. This is valid if “Bus (Bus Select)” is set to L/R or Off.

 You can use CC#93 to control the Send 1 level, and CC#91 to control the Send 2 level. The global MIDI channel specified by "Channel" (p.60) is used for these messages.

IFX2, IFX3, IFX4, IFX5

Here you can edit the effect parameters for insert effects 2, 3, 4, and 5.

Chain to [IFX3...IFX5]

This selects the connection-destination insert effect.

Insert effect 2 can be connected to IFX3–IFX5.

Insert effect 3 can be connected to IFX4–IFX5.

Insert effect 4 does not provide a "ChainTo" setting. It can be connected only to insert effect 5.

 You can't connect from insert effect 5 to another insert effect.

Chain [Off, On]

Pan [L000...C064...R127]

Bus (Bus Select) [Off, L/R]

FX Control Bus [Off, 1, 2]

Send1 [000...127]

Send2 [000...127]

For more information, please see "IFX1" on page 131.

IFX1



Here you can edit the parameters of the insert effect that you selected in the IFX Routing page.

MIDI Effect dynamic modulation (Dmod) is controlled on the global MIDI Channel “Channel” (p.60). For more information, please see “Dmod List (Dynamic Modulation Source List)” on page 292.

Insert Effect 1 (IFX1)

IFX1 Parameters:

Here you can edit the effect parameters for the insert effect selected in the IFX page IFX Routing.

For details on insert effects, refer to “Insert Effects (IFX1–IFX5)” on page 208.

The microSTATION Editor allows you to edit all of the effect parameters.

In the tables on page 217 and following that explain the effect parameters, items listed in the “Full parameter” section are the parameters that can be edited using the microSTATION Editor/Plug-In Editor.

IFX2, IFX3, IFX4, IFX5

Here you can edit the effect parameters for the insert effects selected in the Insert FX Setup page.

The parameters for IFX2–IFX5 are the same as for IFX1.

MFX/TFX (Master/Total Effect)

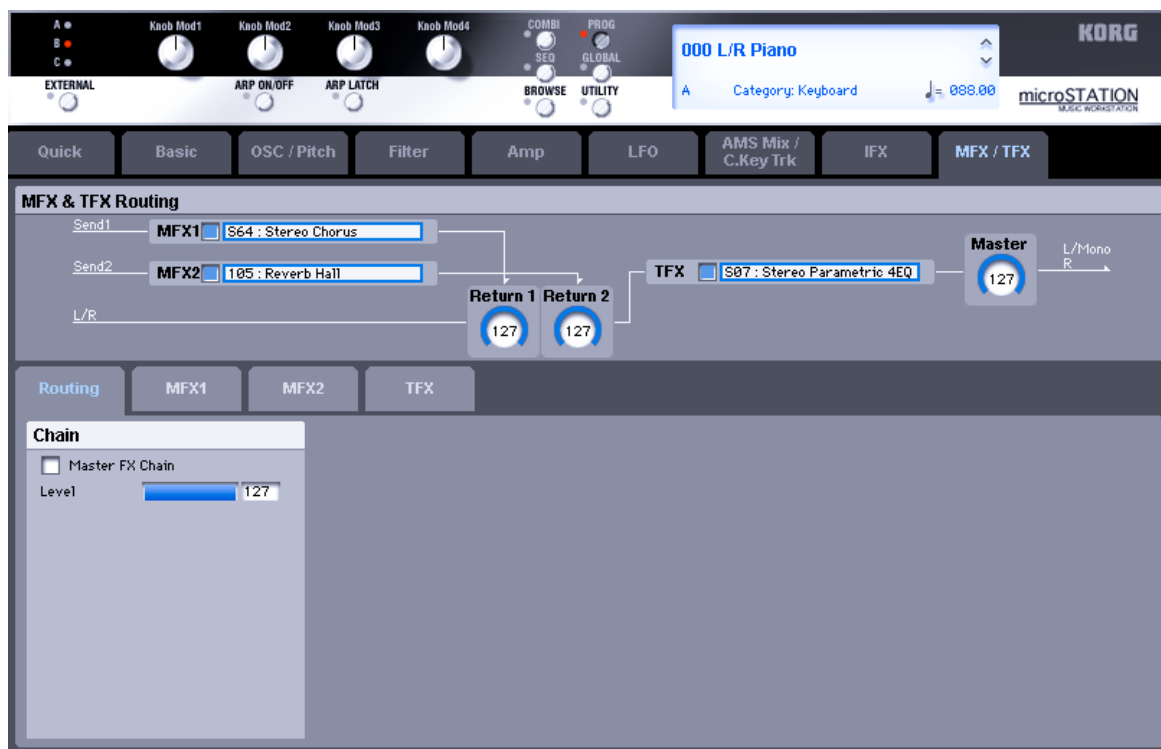

Here, you can adjust the settings for the master effects and total effect. For instance, you can:

- Route a sound to the master effects and total effect
- Make detailed settings for the master effects and total effect

For more information, please see “Effect Guide” on page 205.

MFX&TFX Routing

Here you can specify the type of master effects and total effect, and turn them on/off.

The master effects are sent to the L/R bus. The total effect is inserted into the L/R bus.

MFX1, MFX2

The master effect does not output the direct sound (Dry). Adjust the “Return 1” and “Return 2” return levels to return the signal to the L/R bus and mix it with the L/R bus signal.

The master effects are stereo-in/out, but depending on the selected effect type, the output may be monaural.

For more information, please see “In/Out” on page 208.

On/Off [Off, On]

This switches the master effect 1 on/off. When off, the output will be muted. This will alternate between on and off each time it is pressed.

MIDI Separately from the settings here, you can use control change #94 to turn master effects 1 and 2 off. A value of 0 turns them off, and values of 1–127 restore the original setting. The global MIDI channel specified by

“Channel” (p.60) is used for this message.

MFX1 [S00...S87, D00...D13]

MFX2 [000...120]

These selects the effect type for master effect 1 and 2.

If you choose 000: No Effect, the output from the master effect will be muted.

For master effect1, S01–S87 are single-size and D00–D13 are double-size effects.

For master effect 2, only 000–120 single-size effects can be selected.

Return1, Return2

Return 1 [000...127]

Return 2 [000...127]

These specifies the return level from the master effect to the L/R bus (after which it passes through TFX, and is sent from OUTPUT L/MONO and R).

TFX

These are the parameters for the total effect, which is placed at the final stage of the L/R bus. After passing through the total effect, the sound is output to OUTPUT L/MONO and R.

For the total effect, the direct sound (Dry) is always stereo-in/out. The input/output configuration of the effect sound (Wet) will depend on the selected effect type.

The total effect is stereo-in and stereo-out, but the output may be monaural depending on the type of effect you select. For more information, please see “In/Out” on page 208.

On/Off **[Off, On]**

This turns total effect on/off. If this is off, the input will be passed directly through. The setting will alternate between on/off each time you press this.

 Alternatively, you can send control change #95 to turn the total effect off. A value of 0 turns the total effect off, and values of 1–127 restore the original setting. The global MIDI channel specified by “Channel” (p.60) is used for this message.

TFX **[00...61]**

This selects the effect type for total effect.

TFX cannot use double-size effects (154–170).

Master Volume**Master Volume** **[000...127]**

This specifies the final level of the audio output that has passed through total effect, and output from OUTPUT L/MONO and R.

Routing

Chain**Master FX Chain** **[Off, On]**

On: Master effects 1 and 2 will be connected in series, in the order of master effect 1 → master effect 2.

Level **[000...127]**

When the chain is On, this sets the level where the sound is sent from the first master effect to the next master effect.

 If you select a double-size effect, the “Chain” settings will be ignored.

MFX1

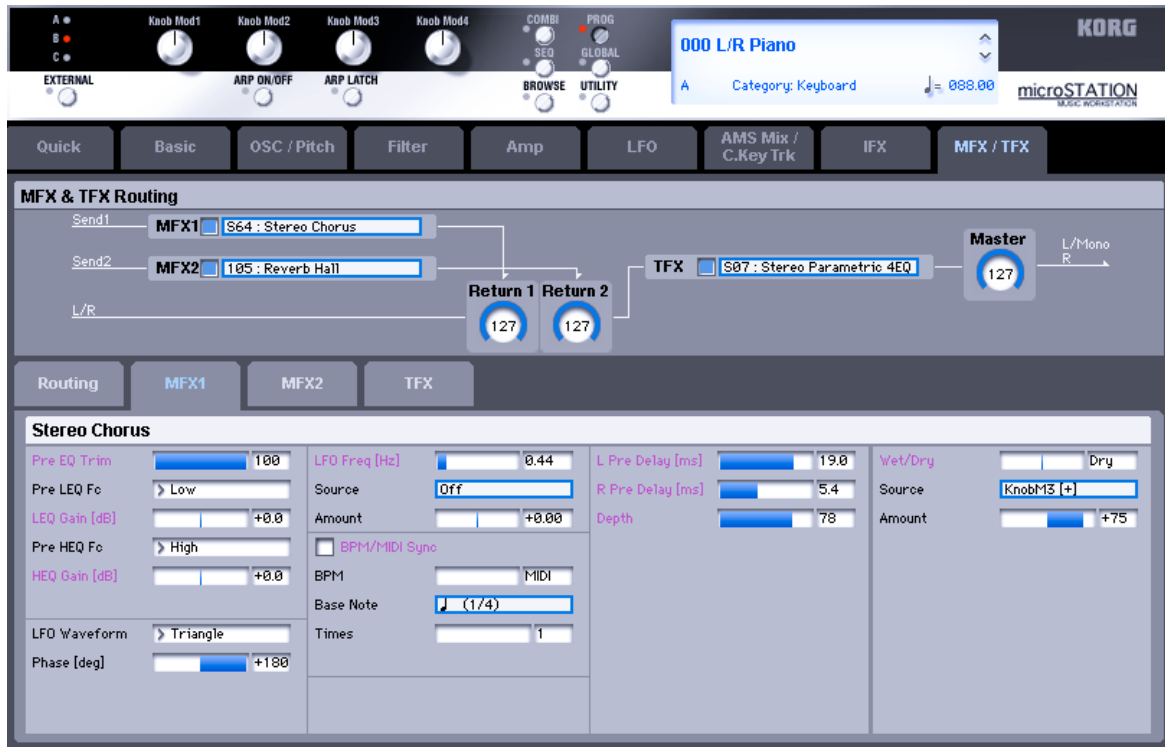

Here you can edit the parameters of the effect you choose for MFX1 in the MFX/TFX page.

MIDI Effect dynamic modulation (Dmod) is controlled on the global MIDI Channel “Channel” (p.60). For more information, please see “Dmod List (Dynamic Modulation Source List)” on page 292.

MFX1 Parameters

Here, you can edit the parameters of the master effect selected in the MFX/TFX page.

For more information, please see “Effect Guide” on page 205.

microSTATION Editor allows you to edit all of the effect parameters.

In the tables on page 217 and following that explain the effect parameters, items listed in the “Full parameter” section are the parameters that can be edited using microSTATION Editor/Plug-In Editor.

TFX

These pages let you edit the parameters of TFX. To select different effects types, use the MFX/TFX page. The parameters for TFX is the same as for MFX2.

MFX2

These pages let you edit the parameters of Master Effect 2. To select different effects types, use the MFX/TFX page.

The parameters for MFX2 is the same as for MFX1.

UTILITY Command

Procedure for utility commands

1. Click the UTILITY button, and choose a command from the menu that appears.
2. Adjust the settings in the dialog box.
For details on the contents of each dialog box, refer to the explanation for each command.
3. Click the OK button to begin, or click the Cancel button if you decide not to continue.

Write Program

This command saves the edited program to the microSTATION's internal memory. You can use this to do the following.

- Save the changes you made.
- Rename a program.
- Specify the category of a program.
- Copy a program to a different bank and program number.

Select Category [KEYBOARD...USER]

Specify the category of the program that you're saving.

Select Sub Category

Specify the sub-category of the program you're saving.

New Name [characters]

Specify the program name.

Choose Destination [000...127: name]

Specify the save-destination for the program.

Copy Oscillator

This command is used to copy the settings from one oscillator to another.

Copy Oscillator is available on all of the tabs under the Quick, Basic, OSC/Pitch, Filter, Amp/EQ pages.

1. Use the "From" field to select the oscillator that you want to copy.
2. Use "Program" to select the bank and number of the copy-source program.
3. In "To," specify the copy destination oscillator.

Swap Oscillator

This command exchanges the settings of oscillators 1 and 2. Swap Oscillator is available on all of the tabs under the Quick, Basic, OSC/Pitch, Filter, Amp/EQ pages.

Note: This can be selected only if Oscillator Mode (p.82) is Double.

Copy EG

This command copies EG settings.

Copy EG is available on all of the tabs under the OSC/Pitch, Filter, Amp/EQ pages.

1. Use "From" to select the copy-source EG.
2. Use "Program" to select the copy-source program.
3. Use "To" to select the copy-destination EG.

selected, you can also use the front-panel BANK buttons to

Copy LFO

This command copies LFO settings.

Copy LFO is available on the LFO pages.

1. Use "From" to select the copy-source LFO.
2. Use "Program" to select the copy-source program.
3. Use "To" to select the copy-destination LFO.

Swap LFO 1&2 of OSC1

This command copies the settings of OSC 1 LFO1 to OSC 1 LFO2, and vice-versa.

Swap LFO 1 & 2 of OSC1 is available on all of the LFO pages, except for the Common LFO tab.

Note: If LFO2 is being used to modulate LFO1, this command will erase that modulation routing (since the LFOs cannot modulate themselves).

Swap LFO 1&2 of OSC2

This command copies the settings of LFO1 to LFO2, and vice-versa.

Swap LFO 1 & 2 is available on all of the LFO pages, except for the Common LFO tab.

These are available only when the Oscillator Mode is set to Double; if not, the command will not be displayed.

Note: If LFO2 is being used to modulate LFO1, this command will erase that modulation routing (since the LFOs cannot modulate themselves).

Copy Arpeggiator

This command can be used to copy arpeggio settings from another location to the current program.

Copy Arpeggiator is available on the ARP tab of the Basic page.

1. Use the From field specify the source of the arpeggio settings (mode, bank, number) that you wish to copy.
2. If you are copying from Combination, or Song, specify whether you wish to copy from A or B.

Copy Insert Effect

This command copies effects settings from within the current Program, from other Programs, Combinations, or Songs.

Copy Insert Effect is available on all of the IFX pages.

To begin the Copy Insert Effect command, press the OK button. To cancel, press the Cancel button.

 If you're copying from a master effect, the result will not be identical due to differences in the routing and level settings of the master effects.

From (Mode) [Program, Combination, Song]

This selects whether you'll copy from a Program, a Combination, or a Song settings.

From (Bank and Number) [Bank and Number]

For Programs and Combinations, this selects the Bank and Number from which to copy. When this parameter is select Banks.

(Effects select) [IFX 1...5, MFX 1&2, TFX]

Select which of the effects you wish to copy.
You can also copy from a master effect and total effect.

All [check-box]

When this is enabled, the settings of all insert effects (the contents of the Insert FX page and the effect parameters of IFX1–5, but not Ctrl Ch) will be copied.

To [IFX 1...5]

This selects the insert effect copy destination.

Swap Insert Effect

This command exchanges the effects, and their internal parameters, between two IFX.

Swap Insert Effect is available on all of the IFX pages.

All of the parameters shown on the IFX 1–5 pages will be copied.

Other IFX parameters will not be affected, including Pan, Sends 1 and 2, Chain, and FX Control Bus.

1. In Source 1 and Source 2, select each of the insert effects that you wish to swap.

Copy MFX/TFX

This command lets you copy any desired effect settings from Program, Combination, or Song.

Copy MFX/TFX is available on all of the MFX/TFX pages.

1. Use the From field to select the copy source mode, bank, and number.
Select the effect that you want to copy.
2. You can copy from an insert effect by selecting IFX1–5.
If you copy from an insert effect, the result may not be exactly the same, due to differences in routing and level settings.
If you select MFX1 or MFX2, the Return level will be copied at the same time.
You can copy settings from a total effect by selecting TFX.
If you check All MFXs, all master effect settings will be copied.
If you check TFX, all total effect settings will be copied.
Master Volume settings will not be copied.
3. In “To,” specify the copy destination master effects or total effect.
This is not shown if copy source is set to M1,2&TFX.

Load

Loads the microSTATION Editor/Plug-In Editor data that was previously saved on the computer.

Save

Saves data from the microSTATION Editor/Plug-In Editor to your computer as dedicated file.

All Data (.MSTall): All data (program, combination, song settings, global settings).

All Prog (.MSTapr): All program data.

Bank Program (.MSTbpr): Program data of the bank that’s currently selected.

Program (MSTpr): A program data that’s currently selected.

Note: These functions load or save the data as dedicated files for the editor application.

Receive All

Receives all data from the microSTATION data into the editor.

Note: The sequencer performance data of Sequencer mode is excepted.

Transmit All

Transmits all data in the microSTATION Editor/Plug-In Editor to the microSTATION and writes it into internal memory.

Receive All Prog/Current Prog Bank

Receive the corresponding data from the microSTATION into the microSTATION Editor/Plug-In Editor.

Transmit All Prog/Current Prog Bank

Transmit all program data from the microSTATION Editor/Plug-In Editor to the microSTATION and writes it.

Transmit Current Prog Bank

Transmit program bank data that’s currently selected bank from the microSTATION Editor/Plug-In Editor to the microSTATION and writes it.

Receive Current Prog

Receive the respective data from the microSTATION into the microSTATION Editor/Plug-In Editor.

Transmit Current Prog

Transmit the program data that’s currently selected from the microSTATION Editor/Plug-In Editor to the microSTATION and writes it.

Note: These Receive and Transmit commands use KORG SysEx MIDI Dump to send or receive data, or to synchronize the data between the microSTATION and the software.

 Don’t touch the keyboard or the mouse of your computer while data is being sent or received. Also, don’t touch the panel switches or the keyboard of the microSTATION.

Import

Loads PCG data from the microSTATION into the microSTATION Editor/Plug-In Editor.

Export

Data created in microSTATION Editor/Plug-In Editor can be saved as PCG data for the microSTATION.

All Sound Off

Depending on the host application, “hung” notes may occur while using the host’s functions. If this happens, please use this command.

Combination mode

By connecting the microSTATION to your computer and using the microSTATION Editor application, you'll be able to edit all of the microSTATION's parameters.

This chapter explains the editable parameters that are shown in the editor. For details on how to select parameters and edit their value, refer to the "microSTATION Editor/Plug-In Editor User's Guide" found on the accessory disc.

Page structure

Panel / Page	Main content
Panel	Select combinations, specify the tempo.
Play	Pan and volume settings etc. for each timbre. (p.142) Simple arpeggiator editing. (p.143)
Common	Arpeggiator settings. (p.143) Realtime controls knob function assignments. (p.144)
Timbre Param	Various parameter settings for each timbre (MIDI channel, OSC selection, Pitch setting, etc.) (p.145) MIDI transmit/receive filter settings. (p.150)
Key/Vel Zone	Key split and layer settings. (Key zone and velocity zone) (p.152)
IFX	Oscillator output bus and master effect send level settings. (p.153) Insert effect routing, selection, and settings. (p.155)
MFX/TFX	Master effect routing, selection, and settings. (p.157) Total effect selection and settings. (p.158)

Panel



microSTATION Editor's panel lets you do the following things.

- Select combinations, and specify the tempo
- Switch the realtime control mode, and use the knobs to edit in each mode.
- Use the external control knobs.

Turn the arpeggiator on/off, and turn the arpeggiator's latch on/off

Mode Select, BROWSER, UTILITY

Mode button [PROG, COMBI, SEQ, GLOBAL]

Click a button to select the mode that you want to edit.

BROWSER button

Clicking the BROWSER button opens a combination sound list. Select a combination from the list and click the OK button to load the combination.

Note: You can click a combination in the list to select it, and then audition that combination from the keyboard.

UTILITY button

The utility functions are various commands available in each page. The available utility commands will differ depending on the page. These commands also let you save or load the edited or created data on your computer, and to import system exclusive data. Click the UTILITY button and choose a command from the menu that appears.

"UTILITY Command" on page 159

Display

Combination Select [A000...C127: name]

To select a combination, click the ▲▼ buttons shown at the right of the combination name.

Tempo [040.00...300.00]

This indicates the tempo. To set the tempo, use COMBI EDIT "Tempo ♩", or use knob 4 in Realtime Control C mode.

The arpeggiator, LFOs, and effects will synchronize to the specified tempo.

Realtime Controls

Select buttons [A, B, C]

These select the realtime control mode.

Click a button A, B, or C to switch modes.

Realtime Control Knob 1...4

These knobs control the function that is assigned for each realtime control mode.

EXTERNAL button [Off, On]

Pressing this button will switch to external control, allowing you to use the knobs to control an external MIDI device or computer application.

Arpeggiator

ARP ON/OFF button [Off, On]

This turns the arpeggiator on/off.

ARP LATCH ON/OFF button [Off, On]

This turns the arpeggiator's Latch function on/off. If this is on, the arpeggio will keep playing even after you take your hands off the keyboard while the arpeggiator is running.

Play



This is the Play page of Combination mode. Among other things, you can:

- Select a program for each timbre, and specify its Play/Mute and Solo On/Off status.
- Use the Realtime controls to make simple edits for program parameters.

received on a MIDI channel that matches the MIDI channel of a timbre whose Status is INT, the program of that timbre will change. However if the MIDI channel of the incoming message matches the global MIDI channel MIDI Channel, then the combination will change.

If you do not want the combination to change, you can either change the global MIDI channel to a MIDI channel other than the channel on which the program change messages are being received, or you can turn off “Combination Change” (p.185). You can also uncheck “Bank Change” so that only the program number will change and the bank will remain the same.

If you wish to change the program assigned to certain timbres without changing the combination, you can also set “Enable Program Change” (p.185) so that the program will change on certain timbres but not on others.

Program Select

Timbre 01...16 (Timbre Number):

Program Select

[001...]

Here you can select the program used by each timbre. Click “Program Select,” and choose from the menu that appears.

MIDI When you select a Combination on the microSTATION, a MIDI program change for the selected combination number will be transmitted on the global MIDI Channel (p.60).

At the same time, bank select, program change, and volume (CC#7) messages will be transmitted on the MIDI channel specified for each timbre whose Status (p.145) is set to EXT or EX2. However, these messages will not be transmitted for timbres that are set to the same MIDI channel as the global MIDI channel.

In this case, EX2 timbres will show the “Program” Bank as “-”, and will transmit the bank number that was specified in Bank Select (When Status=EX2) (p.145). When you play on the microSTATION keyboard and controllers, MIDI messages are transmitted on the global MIDI channel. At the same time, timbres whose Status is set to EXT or EX2 will transmit the same messages on their own MIDI channel.

If bank select and program change messages are

Pan

[RND, L001...C064...R127]

This specifies the pan of each timbre.

L001...C064...R127: A setting of L001 is far left and R127 is far right. A setting of C064 will reproduce the pan setting of the Program mode.

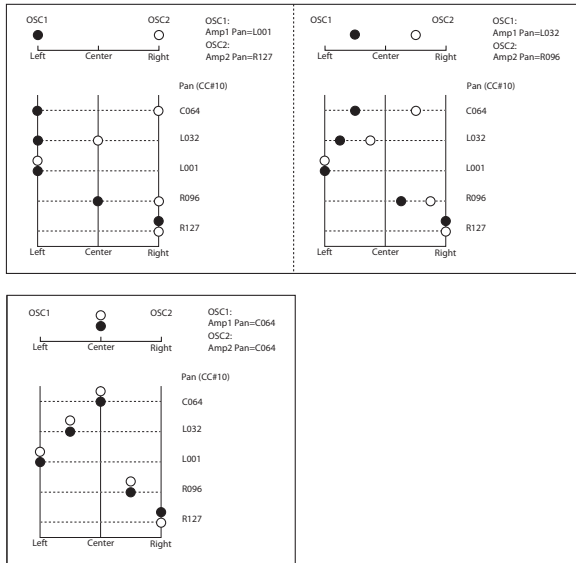

If a mono insert effect is in use, the settings you make here will be ignored. In this case, the “Pan(CC#8)” parameter in IFX-IFX Setup page will adjust the panning of the sound after the insert effect (☞ “Mixer” on page 210).

RND: The oscillator pan will change randomly at each note-on.

MIDI If Status (☞ p.145) is set to INT, CC#10 (pan) messages can be received to control the setting. CC#10 values of 0 or 1 will place the sound at the far left, 64 at center, and 127 at the far right. (exclude RND) Pan settings can be controlled by messages received on the “MIDI Channel” (☞ p.145).

Volume [000...127]
Adjusts the volume of each timbre 1–16.

MIDI The volume of each timbre is determined by multiplying this volume value with the MIDI volume (CC#7) and expression (CC#11).
If Status (☞ p.145) has been set to INT, incoming MIDI CC#7 or CC#11 messages will control the volume of a timbre. (However these messages will not affect the setting of this parameter.)
If Status is EXT or EX2, the value of this parameter will be transmitted as MIDI CC#7 when the combination is changed. However this will not be transmitted by a timbre that is set to the same MIDI channel as the global MIDI channel. This message is transmitted on the MIDI Channel (☞ p.145) specified for each timbre.

Play/Mute [Play, Mute]
This setting mutes a timbre.
Play: The timbre will produce sound.
Mute: The timbre will be muted (silent).

Solo On/Off [Off, On]
Turns the Solo function on/off for each timbre.

Arpeggiator Info

This shows the arpeggiator A and B settings used by the screen.

By clicking a parameter name etc., you can jump to the arpeggiator editing page.

FX Info

This shows the on/off status and effect type of the insert effects, master effects, and total effect used by the combination.

By clicking an effect name etc., you can jump to the effect editing page.

Timbre Mixer

You can set the pan, and volume for each of the Timbres 1–16.

Timbre Mixer

Timbre 01... 16 (Timbre Number):

Play/Mute [Play, Mute]

This setting mutes a timbre.

For more information, please see “Play/Mute” on page 142.

Solo [Off, On]

Turns the Solo function on/off for each timbre.

Pan [RND, L001...C064...R127]

This specifies the pan of each timbre.

For more information, please see “Pan” on page 141.

Volume [000...127]

Adjusts the volume of each timbre.

For more information, please see “Volume” on page 142.

Common



Here you can adjust the settings for the arpeggiator, and select the functions that are assigned to knobs 1–4 when the REALTIME CONTROL SELECT button has selected B mode.

To save the edits you make, use Write Combination.

Arpeggiator Assign

Arpeggiator Assign [Off, A, B]

Assigns arpeggiator A or B to each timbre 1–16. When the ARP ON/OFF button is on, the arpeggiator specified for each timbre will operate according to “Arpeggiator Run A, B” and these settings.

For more information, please see “ARP Assign” on page 19.

Arpeggiator Run A, B [Off, On]

This turns arpeggiator on/off.

For more information, please see “Run” on page 23.

Arpeggiator-A(B)

These parameters specify how the arpeggiator will function within the combination. Two arpeggiators can run simultaneously.

This offers a variety of possibilities, such as applying separate arpeggio patterns to two sounds that have been assigned as a keyboard split, or using velocity to switch between two arpeggio patterns.

You can also use the realtime controls C mode ARP GATE knob, ARP VELOCITY knob, ARP SWING knob, and TEMPO knob to control the arpeggiator in realtime.

Setup

Pattern	[P0...P4, 000...639: name]
Octave	[1, 2, 3, 4]
Resolution	[♪, ♪, ♫, ♫, ♫, ♫]
Gate	[000...100%, Step]
Velocity	[001...127, Key, Step]
Swing	[-100...+100%]
Sort	[Off, On]
Latch	[Off, On]
Key Sync.	[Off, On]
Keyboard	[Off, On]

Here, you can make arpeggiator settings for the combination.

For more information, please see “ARP Setup” on page 9.

Scan Zone

These settings specify the note and velocity ranges that will trigger arpeggiators A and B.

Top Key	[C-1...G9]
Bottom Key	[C-1...G9]

Specifies the range of notes (keys) that will trigger arpeggiator A/B. “Top Key” specifies the upper limit, and “Bottom Key” specifies the lower limit.

Top Velocity [001...127]

Bottom Velocity [001...127]

Specifies the range of velocities that will trigger arpeggiator A/B. "Top Velocity" specifies the upper limit, and "Bottom Velocity" specifies the lower limit.

Note: The values of these parameters can also be entered by holding down the KEY button and playing a note on the keyboard.

Realtime Control Knob Assign

Here you can select the functions (mainly types of control change) that are assigned to knobs 1–4 when the REALTIME CONTROL SELECT button has selected B mode.

Knob 1–B [Off...MIDI CC#119]

Knob 2–B [Off...MIDI CC#119]

Knob 3–B [Off...MIDI CC#119]

Knob 4–B [Off...MIDI CC#119]

The functions you assign here are active when you use the REALTIME CONTROLS SELECT button to select B mode, and operate knobs 1–4.

For a list of AMS sources, please see "Realtime Control Knob 1–4 Assign" on page 294.

Timbre Param (Timbre Parameters)



Scale

Timbre can use the scale that is specified by Scale.
For more information, please see “Scale” on page 82.

Type (Combi’s Scale) [Equal Temperament...User Octave Scale3]

Selects the scale.
For more information, please see “Type” on page 82.

Key [C...B]

This selects the key of the specified scale.
For more information, please see “Key (Scale Key)” on page 83.

Random [0...7]

As this value is increased, an increasingly random deviation will be added to the pitch at each note-on.

MIDI If Status (p.145) is INT, this setting will affect the pitch produced by the microSTATION. If “Status” is EXT, this setting will affect the note number of the note messages transmitted via MIDI.

MIDI/OSC

Here you can adjust MIDI settings for each timbre.

Timbre 01...16 (Timbre Number)

MIDI

Status [Off, INT, EXT, EX2]

This parameter sets whether the Timbre controls the internal sounds, or external MIDI devices.
For more information, please see “Status” on page 80.

MIDI Channel [01...16, Gch]

This parameter allows you to sets the MIDI transmit/receive channel for each timbre.
For more information, please see “MIDI Ch. (MIDI Channel)” on page 20.

Bank Select MSB (When Status = EX2) [000...127]

Bank Select LSB (When Status = EX2) [000...127]

Specifies the bank number that will be transmitted when “Status” is set to EX2. The upper line is the MSB, and the lower line is the LSB. This setting has no effect if “Status” is other than EX2.

OSC

Force OSC Mode [PRG, Poly, Mono, LGT]

This lets you override the Program's stored Voice Assign Mode settings, if desired.

For more information, please see "Oscillator Mode" on page 82.

OSC Select [BTH, OSC1, OSC2]

This parameter specifies whether the timbre's program will play OSC1, OSC2, or both.

For programs whose "Oscillator Mode" is Double, this setting lets you specify that only OSC1 or OSC2 will sound.

BTH (Both): OSC1 and 2 will sound as specified by the settings of the program.

OS1: Only OSC1 will sound.

OS2: Only OSC2 will sound. Programs will not sound if Oscillator Mode is set to Single or Drums.

Portamento [PRG, Off, 001...127]

This parameter allows you to select portamento settings for each timbre.

PRG: Portamento will be applied as specified by the program settings.

Off: Portamento will be off, even if the original program settings specified Portamento to be on.

001...127: Portamento will be applied with the portamento time you specify here, even if it is turned off by the program settings.

MIDI If the "Status" (p.145) is set to INT, CC#05 (portamento time) and CC#65 (portamento switch) messages will be received and will control and change these settings. (If the setting is PRG, CC#05, portamento time will not be received.) These messages will be received on the MIDI channel specified for each timbre by MIDI Channel (p.145).

Pitch/Other



Here, you can adjust pitch, scale, and delay time from note-on settings for each timbre.

Timbre 01...16 (Timbre Number)

Pitch

Transpose [-60...+00...+60]

This parameter adjusts the pitch of each timbre in semitone steps. 12 units equal one octave.

MIDI When "Status" is INT, this parameter will affect the pitches sounded by the microSTATION. When "Status" is EXT, this parameter will affect the note numbers of the MIDI note messages that are transmitted. For example if you create settings of +04 and +07 respectively for two timbres that are set to EXT, playing the C key will transmit a C note number on the global MIDI channel, and at the same time will also transmit E and G note numbers on the MIDI channels of those timbres.

Detune [-1200...+0000...+1200]

This parameter adjusts the pitch of each timbre in one-cent units.

+0000: Normal pitch.

MIDI Transpose and Detune can be controlled via MIDI RPN messages. The way that this works depends on whether or not the Timbre uses a Drum Program.

If the Timbre does not use a Drum Program—for example, if it uses a Single or Double Program—then MIDI RPN Coarse Tune will control Transpose, and RPN Fine Tune will control Detune.

If the Timbre uses a Drum Program, MIDI RPN Coarse Tune and Fine Tune will be combined to control Detune. The overall range is ±1 octave for coarse tune and fine tune together.

Bend Range [PRG, -24...+00...+24]

Specifies the maximum amount of pitch change (in semitones) that will occur when the pitch bender is used.

PRG: The pitch range specified by the program will be used.

-24...+24: This setting will be used regardless of the setting in the program.

MIDI The MIDI RPN Pitch Bend Change message can be received to control this and change the setting. (However it will not be received if this parameter is set to PRG.) This message is received on the MIDI channel for each timbre set by MIDI Channel (☞ p.145).

Delay

Delay Time [ms] [0000...5000ms, KeyOff]

Specifies the time (delay time) from note-on until the timbre begins to produce sound, in units of ms (1/1000th of a second). This setting is available if MIDI/Tempo Sync. is set to Off.

KeyOff: The note will begin sounding at note-off. In this case, the sound will not die away if the sustain level of the program's amp EG is other than 0. This setting is used when creating harpsichord sounds.

Normally you will set this to 0000.

Tempo Sync (MIDI/Tempo Sync) [Off, On]

The time (delay time) from note-on until the timbre produces sound will be specified in note length units relative to the "♪ (Tempo)."

On: Specify the delay time in terms of a "Base Note" and "Times" relative to the Tempo. For example if "Base Note" = ♩, "Times" = 01, and "Tempo" = 60 BPM, the delay time will be equivalent to 1000 ms.

Off: The delay time will be set by the Delay Time setting.

Tone

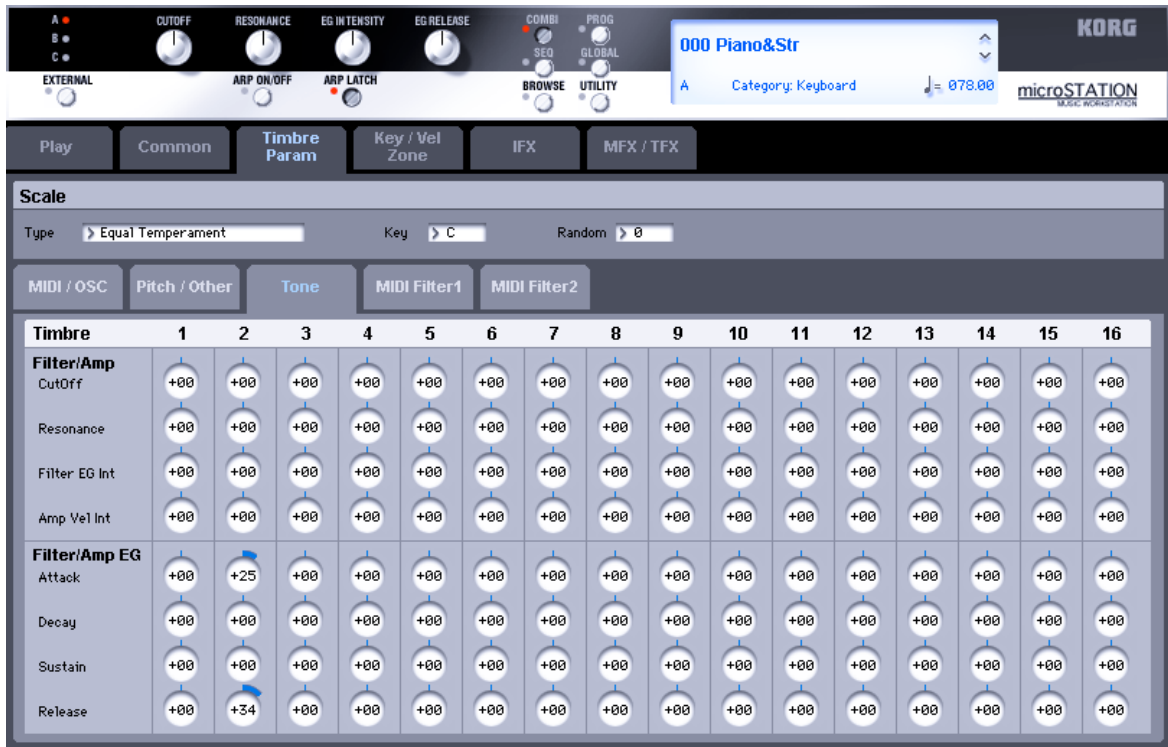

Here you can adjust the sound of each timbre's program. These settings are saved in each combination, and do not affect the original programs.

Timbre 01...16 (Timbre Number)

Filter/Amp

- Cutoff** [-99...+99] (Rel, CC#74)
- Resonance** [-99...+99] (Rel, CC#71)
- Filter EG Int** [-99...+99] (Rel, CC#79)
- Amp Vel Int** [-99...+99] (Rel)

See "Filter/Amp EG" on page 21.

Filter/Amp EG

- Attack** [-99...+99] (Rel, CC#73)
- Decay** [-99...+99] (Rel, CC#75)
- Sustain** [-99...+99] (Rel, CC#70)
- Release** [-99...+99] (Rel, CC#72)

See "Filter/Amp EG" on page 21.

About the Tone parameters

The Tone parameters of a combination have the following characteristics.

- They allow you to edit some of the Tone parameters of the program selected for the timbre.
- They can be set individually for timbres 1–16.
- All of the Tone parameters are Relative parameters. Parameters that are interrelated with specific MIDI CC messages are followed by an indication such as "(CC#74)."

For more about Relative parameters, refer to "Relative (Rel) and Absolute parameters" (p.79)

Saving your edits of Relative parameters

The way that Relative and Absolute parameters are saved will differ in Program mode, but in Combination mode there are no differences in how these parameters are saved. The changes you make are saved in the combination, and will not affect the original programs.

MIDI Filter1



These settings allow you to apply filters to the MIDI data that will be transmitted and received by each timbre. For more information, please see “MIDI Filter” on page 22.

Timbre 01...16 (Timbre Number)

Program Change [Off, On]

Specifies whether or not MIDI program change messages will be transmitted and received.

After Touch [Off, On]

Specifies whether or not MIDI after touch messages will be received.

Damper [Off, On]

Specifies whether or not MIDI CC#64 hold (damper pedal) messages will be transmitted and received.

Portamento SW [Off, On]

Specifies whether or not MIDI CC#65 portamento on/off messages will be transmitted and received.

JS X as AMS [Off, On]

Specifies whether or not MIDI pitch bend messages (the X axis of the joystick) will be received to control the AMS effect assigned to JS X. (This is not a filter for MIDI pitch bend message reception.)

JS+Y [Off, On]

Specifies whether MIDI CC#1 (the +Y axis of the joystick, or a realtime control knob assign setting) will be transmitted and received.

JS-Y [Off, On]

Specifies whether MIDI CC#2 (the -Y axis of the joystick, or a realtime control knob assign setting) will be transmitted and received.

Ribbon (CC#16) [Off, On]

Specifies whether or not MIDI CC#16 (specified as the assignment of a realtime control knob) will be transmitted or received.

Foot SW [Off, On]

Specifies whether or not the effect of the assignable switch will be transmitted and received. The function is assigned in Global: Basic/Controllers– Controllers page.

This filter setting is valid when a MIDI control change is assigned.

Foot Pedal [Off, On]

Specifies whether or not the effect of the assignable pedal will be transmitted and received. The function is assigned in Global: Basic/Controllers– Controllers page.

This filter setting is valid when a MIDI control change is assigned.

Other CC [Off, On]

Specifies whether or not MIDI control messages not covered in the preceding items MIDI Filter will be transmitted and received.

MIDI Filter2



These are MIDI filter settings for the knobs when the REAL-TIME CONTROL SELECT button is used to select Realtime Control A mode or B mode.

Use the Common-Controllers page to assign the functions that knobs 1–4 will perform when Realtime Control B mode is selected.

- RTC Knob B1** [Off, On]
- RTC Knob B2** [Off, On]
- RTC Knob B3** [Off, On]
- RTC Knob B4** [Off, On]

These settings enable or disable transmission and reception of the MIDI messages assigned to knobs 1–4 when the Realtime Control B mode is selected.

Timbre 01...16 (Timbre Number)

RTC Knob A1 [Off, On]

Enables or disables transmission and reception of MIDI CC#74 (the microSTATION's filter cutoff frequency). This is assigned to knob 1 when Realtime Control A mode is selected.

RTC Knob A2 [Off, On]

Enables or disables transmission and reception of MIDI CC#71 (the microSTATION's filter resonance level). This is assigned to knob 2 when Realtime Control A mode is selected.

RTC Knob A3 [Off, On]

Enables or disables transmission and reception of MIDI CC#79 (the microSTATION's filter EG intensity). This is assigned to knob 3 when Realtime Control A mode is selected.

RTC Knob A4 [Off, On]

Enables or disables transmission and reception of MIDI CC#72 (the microSTATION's filter/amp EG release time). This is assigned to knob 4 when Realtime Control A mode is selected.

Key/Vel Zone (Keyboard/Velocity Zone)

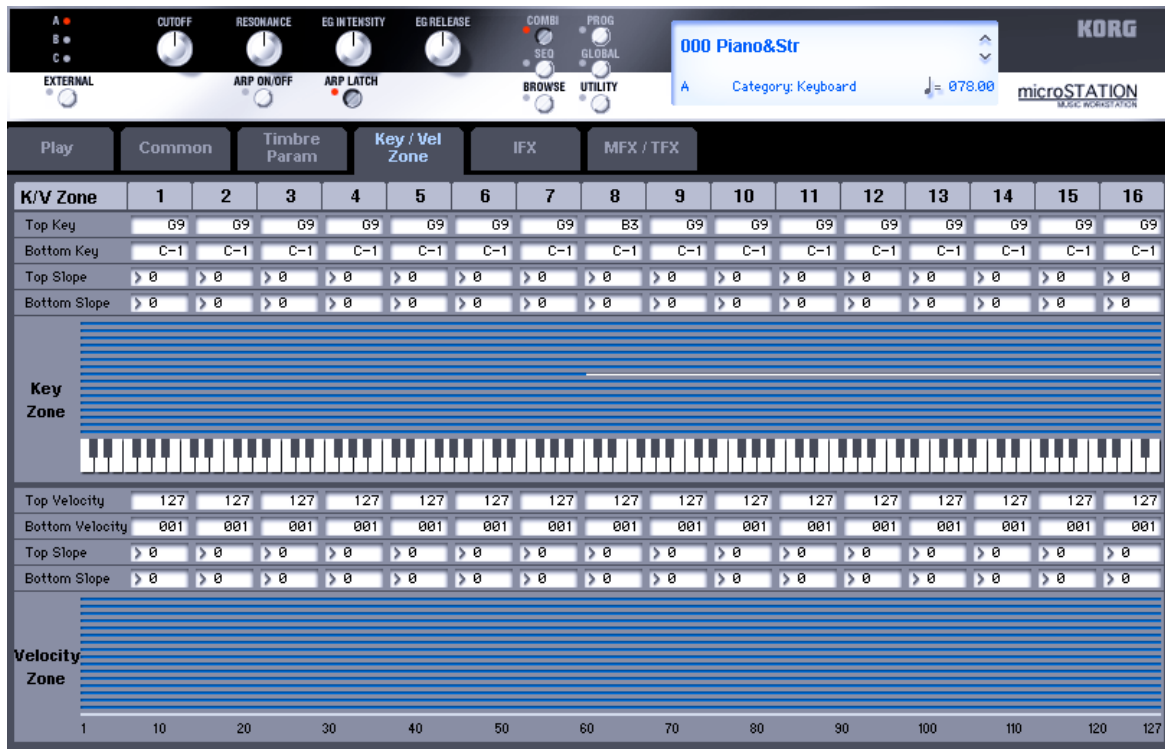

Keyboard Zones

These settings specify the keyboard range in which timbres will sound.

For more information, please see “Key Zone” on page 21.

Timbre 01... 16 (Timbre Number):

Top Key [C-1...G9]

Specifies the top key (upper limit) of the notes that will sound each timbre.

Top Slope [00, 01, 02, 03, 04, 06, 08, 10, 12, 18, 24, 30, 36, 48, 60, 72]

Specifies the range of keys (12 is one octave) over which the volume will be reached starting from the top key.

For more information, please see “Top Slope” on page 21.

Bottom Slope [00, 01, 02, 03, 04, 06, 08, 10, 12, 18, 24, 30, 36, 48, 60, 72]

Specifies the range of keys (12 is one octave) over which the volume will be reached starting from the bottom key.

For more information, please see “Btm Slope” on page 21.

Bottom Key [C-1...G9]

Specifies the bottom key (lower limit) of the notes that will sound each timbre.

For more information, please see “Bottom (Bottom Key)” on page 21.

Keyboard Zone Map

This area indicates the note and velocity ranges in which each timbre will sound.

The display uses lines to indicate the range of notes and velocities that will sound, and show the slope portion.

Velocity Zone

Sets the Top/Bottom Velocity parameters to specify the range of velocities that will sound for each timbres, and set the Top/Bottom Slope parameters to specify the range over which the volume will change. For more information, please see “Vel Zone (Velocity Zone)” on page 22.

Timbre 01... 16 (Timbre Number):

Top Velocity [001...127]

Specifies the maximum velocity value that will sound each timbre.

Top Slope [000...120]

Specifies the number of velocity steps over which the original volume will be reached, starting from the Top Velocity.

For more information, please see “Top Slope” on page 22.

Bottom Slope [000...120]

Specifies the number of velocity steps over which the original volume will be reached, starting from the Bottom Velocity.

For more information, please see “Btm Slope” on page 22.

Bottom Velocity [001...127]

Specifies the minimum velocity value that will sound each timbre. For more information, please see “Bottom (Bottom Velocity)” on page 22.

Velocity Zone Map

This area indicates the note and velocity ranges in which each timbre will sound.

The display uses lines to indicate the range of notes and velocities that will sound, and show the slope portion.

IFX (Insert Effect)

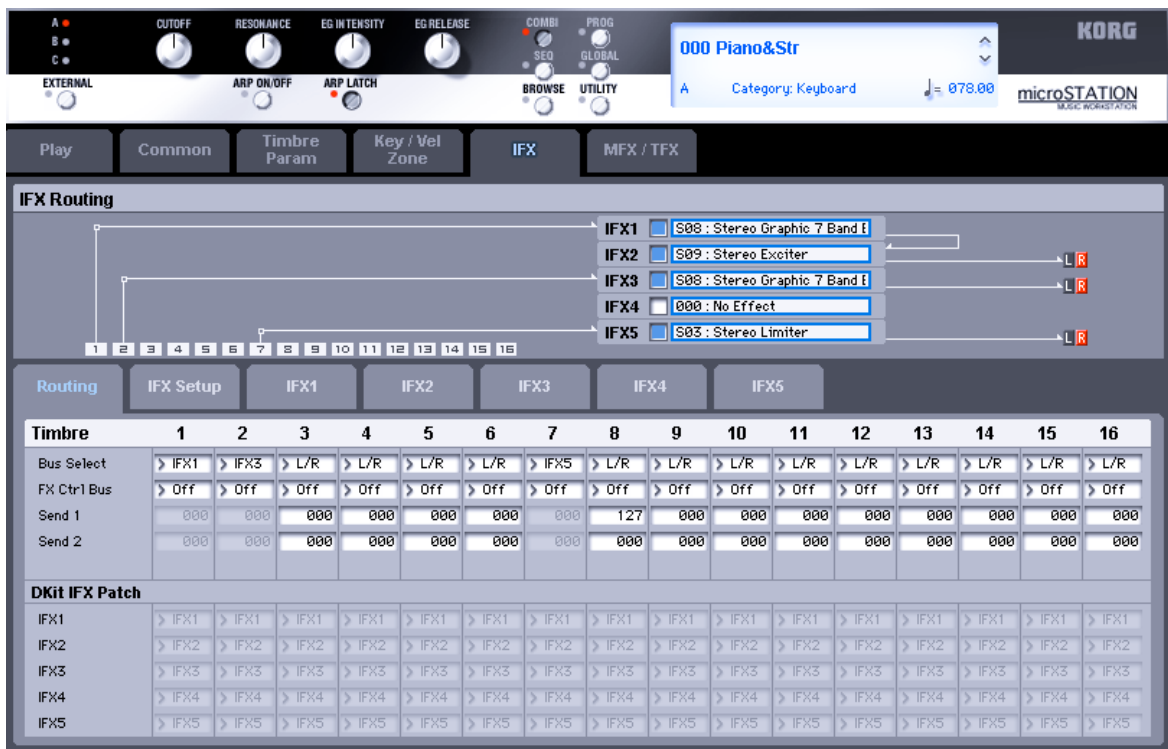

In this page you can adjust the settings for the insert effects. These settings consist mainly of the following.

- Specify the routing for each timbre.
- Select the effect type for insert effects 1–5, and edit the effect parameters.
- Specify on/off and chain settings for insert effects 1–5.
- Adjust mixer settings following the insert effects.

IFX Routing

This shows the status of the insert effects.

This area shows the insert effect routing (“Bus Select”), the name of the assigned effect, the on/off status, chaining, and the output bus that follows the insert effect.

The type of insert effect, the on/off status, and the chain settings can be edited in the IFX Setup page.

IFX1 On/Off	[Off, On]
IFX2 On/Off	[Off, On]
IFX3 On/Off	[Off, On]
IFX4 On/Off	[Off, On]
IFX5 On/Off	[Off, On]
IFX1	[S00...S63, D00...D10]
IFX2	[S00...S61, D00...D09]
IFX3	[S00...S61, D00...D09]
IFX4	[S00...S61, D00...D09]
IFX5	[000...061]

See “IFX Routing” on page 129.

Routing

Specifies the bus where the program oscillator(s) used by timbres 1–16 will be sent. You can also set the send levels to the master effects from this page.

Routing

Timbre 01...16 (Timbre Number):

Bus Select [DKit, L/R, IFX1...IF5, Off]

This specifies the output bus for the timbre’s program oscillator. This parameter can also be edited from the IFX Routing page.

L/R: Output to the L/R bus.

IFX1...IFX5: Output to the IFX1–5 buses.

Off: The timbre will not be output from the L/R bus, or IFX1–5 buses. Choose the Off setting if you want the program oscillator output of the timbre to be connected in series to a master effect. Use Send1 (to MFX1) and Send2 (to MFX2) to specify the send levels.

Tip: You can create a wide variety of routings by using each timbre’s “Bus Select” and the “Chain to” and “Chain” settings (p.155) that follow the insert effect.

Example: Inserting a single IFX into multiple timbre

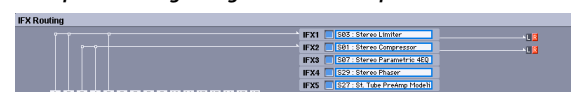

Example: Inserting a separate IFX into each timbre, and then inserting an IFX at the final stage



Example: Sharing a portion of a timbre's IFX chain with another timbre



DKit: This can be selected only if the timbre's program is a drum program (Oscillator Mode Drums).

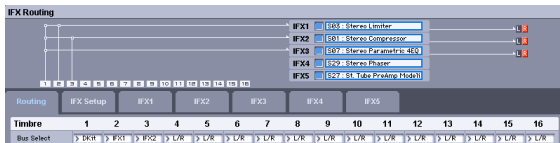

The "Bus (IFX/Output)," "FX Control Bus," "Send1," and "Send2" settings for each key of the selected Dkit will be used. Turn on this setting if you want to apply an individual insert effect to each drum instrument.

Tip: In most preloaded drumkits, the drum instruments have the same "Bus (IFX/Output)" settings according to their type, as follows.

Snares → IFX1

Kicks → IFX2

Other → IFX3

If you want to edit these routings, use the "DrumKit IFX Patch."

For more information, please see "DrumKit IFX Patch" on page 154.

FX Ctrl Bus [Off, 1, 2]

See "FX Ctrl Bus" on page 154.

Send1 (MFX1) [000...127]

Send2 (MFX2) [000...127]

See "Send to MFX1" on page 129.

DrumKit IFX Patch

This patches the "Bus (IFX/Output)" settings for each key of a drum kit, temporarily changing the insert effect connection destinations.

Note: You can utilize this parameter if the program assigned to the timbre is a drum program and "Bus" Out is set to DKit. The "Bus (IFX/Output)" setting of each key in the drum kit must be set to one of IFX1-5.

IFX Setup



Here, you can choose the type of each insert effect 1 through 5, its on/off status, chaining, and adjust the post-IFX mixer settings. For insert effects, the direct sound (Dry) is always stereo-in and out. The input/output configuration of the effect sound (Wet) depends on the effect type.

For detailed explanations of the individual effects, please see the “Effect Guide” on page 205.

The following parameters are the same as in Program mode. For more information, please see “IFX Setup” on page 131.

However, unlike in Program mode, you can use a different MIDI channel to modulate each effect, if desired. This includes the post-IFX “Pan,” “Send1,” and “Send2” settings, as well as the effect’s dynamic modulation (Dmod). To set the MIDI channel, use the “Control Ch” parameter on the IFX 1–5.

IFX1

Chain to	[IFX2...IFX5]
Chain	[Off, On]
Pan	[L000...C064...R127]
Bus (Bus Select)	[Off, L/R]
FX Control Bus	[Off, 1, 2]
Send1	[000...127]
Send2	[000...127]

See “IFX Setup” on page 131.

Control Ch

[Ch01...16, Global Channel, All-Routed]

This parameter specifies the MIDI channel that will be used to control effect dynamic modulation (Dmod), pan following the insert effect “Pan,” “Send 1,” and “Send 2.”

For more information, please see “Ctrl Ch (Control Channel)” on page 25.

IFX2, IFX3, IFX4, IFX5

Here you can edit the effect parameters for insert effects 2–5 selected in the IFX Setup page. These parameters are the same as in Program mode.

See “IFX Setup” on page 131.

IFX1



Here, you can set the effect parameters of the insert effect you chose in the Insert FX Routing.

IFX1 Parameters:

IFX Parameters

Here you can edit the effect parameters for the insert effect. For more details, please see “Effect Guide” on page 205. microSTATION Editor allows you to edit all of the effect parameters. In the tables on page 217 and following that explain the effect parameters, items listed in the “Full parameter” section are the parameters that can be edited using microSTATION Editor/Plug-In Editor.

IFX2, IFX3, IFX4, IFX5

Here you can edit the effect parameters for insert effects 2–5 selected in the IFX Routing. The parameters are the same as in insert effect 1.

For more details, please see “Effect Guide” on page 205.

MFX/TFX (Master/Total Effect)



In this page you can adjust the settings for the master effects and the total effect. These settings consist mainly of the following.

- Specify the routing for the master effects.
- Select the effect type for the master effects and the total effect, and edit the effect parameters.
- Turn each effect on/off.
- Edit the return level to the L/R bus for the master effect outputs.

MFX&TFX Routing

Here you can specify the type of master effects and total effect, and turn them on/off.

The master effects are sent to the L/R bus. The total effect is inserted into the L/R bus.

These parameters are the same as in Program mode.

MFX1, MFX2

Here, you can adjust settings for the master effect 1, 2.

MFX1 On/Off	[Off, On]
MFX2 On/Off	[Off, On]
MFX1	[S00...S87, D00...D13]
MFX2	[000...120]

See “MFX&TFX Routing” on page 134.

Return1, Return2

Return 1 [000...127]

Return 2 [000...127]

See “MFX&TFX Routing” on page 134.

TFX

Here you can adjust the settings for the total effect.

TFX On/Off [Off, On]

TFX [000...153]

See “MFX&TFX Routing” on page 134.

Master Volume

Master Volume [000...127]

This specifies the final level of the audio output that has passed through total effect, and output from OUTPUT L/ MONO and R.

Routing

Chain

Master FX Chain [Off, On]

Chain Level [000...127]

See “Chain” on page 135.

Control Channel

MFX1 [1...16, Global Channel]

MFX2 [1...16, Global Channel]

TFX [1...16, Global Channel]

Specifies the MIDI channel that will control dynamic modulation (Dmod) for the master and total effect.

Ch01...Ch16: The specified MIDI channel will be used for control.

MFX1



Here you can edit the parameters of the effect you choose for MFX1 in the MFX/TFX Routing.

MIDI Effect dynamic modulation (Dmod) is controlled on the global MIDI Channel "Channel" (p.184). For more information, please see "Dmod List (Dynamic Modulation Source List)" on page 292.

MFX1 Parameters

Here, you can edit the parameters of the master effect selected in the MFX/TFX page.

For more information, please see "Effect Guide" on page 205.

microSTATION Editor allows you to edit all of the effect parameters.

In the tables on page 217 and following that explain the effect parameters, items listed in the "Full parameter" section are the parameters that can be edited using microSTATION Editor/Plug-In Editor.

MFX2

These pages let you edit the parameters of Master Effect 2. To select different effects types, use the MFX/TFX Routing. The parameters for MFX2 is the same as for MFX1.

TFX

These pages let you edit the parameters of TFX. To select different effects types, use the MFX/TFX page. The parameters for TFX is the same as for MFX2.

UTILITY Command

Procedure for utility commands

1. Click the UTILITY button, and choose a command from the menu that appears.
2. Adjust the settings in the dialog box.
For details on the contents of each dialog box, refer to the explanation for each command.
3. Click the OK button to begin, or click the Cancel button if you decide not to continue.

Write Combination

This saves the edited combination to the microSTATION's memory.

Select Category [KEYBOARD...USER]

Select the category for the combination you're saving.

Select Sub Category

Select the category for the combination you're saving.

New Name [characters]

Specify the combination name.

To [A000...C127: name]

Specify the save-destination for the combination.

Initialize Combination

This command initializes the settings of the combination that's currently selected.

Initialize Combination is available on all of the tabs under the Quick, Common pages.

Copy from Program

This command copies the settings of the specified program to the combination that's currently selected.

Copy from Program is available on all of the tabs under the Quick pages.

See "Copy Prog (Copy from Program)" on page 27.

Copy Arpeggiator

This command copies arpeggio settings.

Copy Arpeggiator is available on Common page.

See "Copy ARP (Copy Arpeggio)" on page 27.

Copy Insert Effect

This command copies effect settings from a specified program, combination, or song.

However, the "Ch (Control Channel)" setting is not copied.

For more information, please see "Copy IFX" on page 14.

Copy Insert Effect is available on all of the IFX pages.

Swap Insert Effect

This command swaps (exchanges) the settings of two insert effects.

However, the "Ch (Control Channel)" setting is not swapped.

For more information, please see "Swap IFX" on page 14.

Swap Insert Effect is available on all of the IFX pages.

Copy MFX/TFX

This command copies effect settings from a specified program, combination, or song.

However, the "Ch (Control Channel)" setting is not copied.

For more information, please see "Copy MFX/TFX" on page 14.

Copy MFX/TFX is available on all of the MFX/TFX pages.

Load

Loads the microSTATION Editor/Plug-In Editor data that was previously saved on the computer.

Save

Saves data from the microSTATION Editor/Plug-In Editor to your computer as dedicated file.

All Data (.MSTall): All data (program, combination, song, global data) .

All Combi (.MSTacm): All combination data.

Bank Combi (.MSTbcm): Combination data of the bank that's currently selected.

Combi (.MSTcm): A combination data that's currently selected.

Note: These functions load or save the data as dedicated files for the editor application.

Receive All

Receives all data (program, combination, song, global data) from the microSTATION data into the editor.

Note: The sequencer performance data of Sequencer mode is excepted.

Transmit All

Transmits all data (program, combination, song settings, global settings) in the microSTATION Editor/Plug-In Editor to the microSTATION and writes it into internal memory.

Receive All Combi

Receives the all combination data from the microSTATION into the microSTATION Editor/Plug-In Editor.

Receive Current Combi Bank

Receives the combination data of the bank that's currently selected from the microSTATION into the microSTATION Editor/Plug-In Editor.

Transmit All Combi

Transmits the all combination data from the microSTATION Editor/Plug-In Editor to the microSTATION and writes it.

Transmit Current Combi Bank

Transmits the combination data of the bank that's currently selected from the microSTATION Editor/Plug-In Editor to the microSTATION and writes it.

Receive Current Combi/

Receives the combination data that's currently selected from the microSTATION into the microSTATION Editor/Plug-In Editor.

Transmit Current Combi

Transmits the combination data that's currently selected from the microSTATION Editor/Plug-In Editor to the microSTATION and writes it.

Import

Loads PCG data from the microSTATION into the microSTATION Editor/Plug-In Editor.

Export

Data created in microSTATION Editor/Plug-In Editor can be saved as PCG data for the microSTATION.

All Sound Off

Depending on the host application, "hung" notes may occur while using the host's functions. If this happens, please use this command.

Sequencer mode

If you connect the microSTATION to your computer and use the microSTATION Editor/Plug-In Editor, you'll be able to edit all of the microSTATION's parameters.

This chapter explains the parameters that can be viewed and edited in microSTATION Editor/Plug-In Editor. For details on how to select a parameter and edit its value, refer to the "microSTATION Editor/Plug-In Editor User's Guide" provided in the accessory disc.

 Performance data recorded on the microSTATION itself cannot be edited or saved using microSTATION Editor/Plug-In Editor.

Page structure

Panel / Page	Main content
Panel	Select a song, specify the tempo. Realtime control. External control. (☞p.162) Turn the arpeggiator on/off, turn latch on/off. (☞p.162)
Play	Program selection for each track. (☞p.163) Pan and volume settings etc. for each track. (☞p.163) Simple arpeggiator editing. (☞p.164)
Common	Arpeggiator settings. (☞p.164) Realtime controls knob function assignments. (☞p.165)
Track Param	Various parameter settings for each track (MIDI channel, OSC selection, Pitch setting, Time delay from note-on to beginning of sound. etc.) (☞p.166) MIDI transmit/receive filter settings. (☞p.169)
Key/Vel Zone	Key split and layer settings. (Key zone and velocity zone)(☞p.171)
IFX	Oscillator output bus and master effect send level settings. (☞p.172) Insert effect routing, selection, and settings. (☞p.172)
MX/TFX	Master effect routing, selection, and settings. (☞p.175) Total effect selection and settings.(☞p.175)

Panel



microSTATION Editor's panel lets you do the following things.

- Select songs, and specify the tempo
- Switch the realtime control mode, and use the knobs to edit in each mode.
- Use the external control knobs.
- Turn the arpeggiator on/off, and turn the arpeggiator's latch on/off

Mode Select, BROWSER, UTILITY

Mode button [PROG, COMBI, SEQ, GLOBAL]

Click a button to select the mode that you want to edit.

BROWSER button

Click the BROWSER button to view a song list. Select a song in the list and click the OK button to load the song.

UTILITY button

The utility functions are various commands available in each page. The available utility commands will differ depending on the page. These commands also let you save or load the edited or created data on your computer, and to import system exclusive data. Click the UTILITY button and choose a command from the menu that appears.

"UTILITY Command" on page 177

Display

Song Select [A000...C127: name]

To select a song, click the ▲▼ buttons shown at the right of the song name.

Tempo [040.00...300.00]

This indicates the tempo. To set the tempo, use SEQ EDIT "Tempo $\frac{♩}{4}$ ", or use knob 4 in Realtime Control C mode.

The arpeggiator, LFOs, and effects will synchronize to the specified tempo.

Realtime Controls

Select buttons [A, B, C]

These select the realtime control mode. Click a button A, B, or C to switch modes.

Realtime Control Knob 1...4

These knobs control the function that is assigned for each realtime control mode.

EXTERNAL button [Off, On]

Pressing this button will switch to external control, allowing you to use the knobs to control an external MIDI device or computer application.

Arpeggiator

ARP ON/OFF button [Off, On]

This turns the arpeggiator on/off.

ARP LATCH ON/OFF button [Off, On]

This turns the arpeggiator's Latch function on/off. If this is on, the arpeggio will keep playing even after you take you

Play



Track Select, Program Select, Pan, Volume

Track Select

[1...16]

To select a track, click a track number 1–16 at the left of “Program Select.” This will select the tracks that will sound during playback, or the tracks that will be recorded.

Track 01...16 (Track Number):

Program Select [Category: 000...127: Name]

Selects the program that will be used by each MIDI track. (☞ “Program Select” on page 36)

Pan [RND, L001...C064...R127]

Here, you can set the pan of each MIDI track. (☞ “Pan” on page 37)

Volume [000...127]

Here, you can set the volume of each MIDI track. (☞ “Volume” on page 37)

Arpeggiator Info

This shows the arpeggiator A and B settings used by the screen.

By clicking a parameter name etc., you can jump to the arpeggiator editing page.

FX Info

This shows the on/off status and effect type of the insert effects, master effects, and total effect used by the song.

By clicking an effect name etc., you can jump to the effect editing page.

Track Mixer

Track 01...16 (Track Number):

Play/Mute

[Play, Mute]

Use this to mute a MIDI track. (☞ “Play/Mute” on page 37)

Solo

[On, Off]

Turns the Solo function on/off for each track. Only tracks with Solo On will sound. Other tracks will be muted.

The setting will alternate on/off each time you press the Solo button.

MIDI If MIDI tracks whose Status (☞ p.38) is BTH, EXT, or EX2 are muted by Mute or by the Solo function, note on/off messages will not be transmitted on the MIDI channel selected for those tracks.

⚠ Solo settings are not saved with the song.

Pan

[RND, L001...C064...R127]

Here, you can set the pan of each MIDI track. (☞ “Pan” on page 37)

Volume

[000...127]

Here, you can set the volume of each MIDI track. (☞ “Volume” on page 37)

Common



Here you can adjust the settings for the arpeggiator, and select the functions that are assigned to knobs 1–4 when the REAL-TIME CONTROL SELECT button has selected B mode.

Arpeggiator Assign

Arpeggiator Run A, B [Off, On]

This turns arpeggiator on/off.

For more information, please see “Run” on page 46.

Track 01...16 (Track Number):

Arpeggiator Assign [Off, A, B]

Assigns arpeggiator A or B to each track 1–16.

For more information, please see “ARP Assign” on page 37.

Arpeggiator–A(B)

These parameters specify how the arpeggiator will function within the song. Two arpeggiators can run simultaneously. This offers a variety of possibilities, such as applying separate arpeggio patterns to two sounds that have been assigned as a keyboard split, or using velocity to switch between two arpeggio patterns.

You can also use the realtime controls C mode ARP GATE knob, ARP VELOCITY knob, ARP SWING knob, and TEMPO knob to control the arpeggiator in realtime.

Setup

Pattern [P0...P4, 000...639: name]

Octave [1, 2, 3, 4]

Resolution [♪₃, ♪, ♪₃, ♪, ♪₃, ♪]

Gate [000...100%, Step]

Velocity [001...127, Key, Step]

Swing [–100...+100%]

Sort [Off, On]

Latch [Off, On]

Key Sync. [Off, On]

Keyboard [Off, On]

Here, you can make arpeggiator settings for the combination.

For more information, please see “ARP Setup” on page 9.

Scan Zone

These settings specify the note and velocity ranges that will trigger arpeggiators A and B.

Top Key [C–1...G9]

Bottom Key [C–1...G9]

Specifies the range of notes (keys) that will trigger arpeggiator A/B. “Top Key” specifies the upper limit, and “Bottom Key” specifies the lower limit.

Top Velocity [001...127]

Bottom Velocity [001...127]

Specifies the range of velocities that will trigger arpeggiator A/B. “Top Velocity” specifies the upper limit, and “Bottom Velocity” specifies the lower limit.

Realtime Control Knob Assign

Here you can select the functions (mainly types of control change) that are assigned to knobs 1–4 when the REALTIME CONTROL SELECT button has selected B mode.

Knob 1–B [Off, ...MIDI CC#119]

Knob 2–B [Off, ...MIDI CC#119]

Knob 3–B [Off, ...MIDI CC#119]

Knob 4–B [Off, ...MIDI CC#119]

The functions you assign here are active when you use the REALTIME CONTROLS SELECT button to select B mode, and operate knobs 1–4.

For a list of AMS sources, please see “Realtime Control Knob 1–4 Assign” on page 294.

Track Param (Track Parameters)



Scale

This specifies the scale that the song will use.
For more information, please see “Scale” on page 82.

Type (Song’s Scale)
[Equal Temperament...User Octave Scale15]

Selects the scale.
For more information, please see “Type” on page 82.

Key [C...B]

Selects the key of the specified scale.
For more information, please see “Key (Scale Key)” on page 83.

Random [0...7]

As this value is increased, an increasingly random deviation will be added to the pitch at each note-on.

MIDI If Status (p.38) is INT, this setting will affect the pitch produced by the microSTATION. If Status is EXT, this setting will affect the note number of the note messages transmitted via MIDI.

MIDI/OSC

Here you can make MIDI settings for each timbre.

Track 01...16 (Track Number)

MIDI

Status [Off, INT, BTH, EXT, EX2]

This sets whether the Track controls the internal sounds, or external MIDI devices.

For more information, please see “Status” on page 38.

MIDI Channel [01...16]

Specifies the MIDI channel that the MIDI track will use to transmit and receive musical data.
For more information, please see “MIDI Ch. (MIDI Channel)” on page 39.

Bank Select MSB (When Status=EX2) [000...127]

Bank Select LSB (When Status=EX2) [000...127]

Specifies the bank number that will be transmitted when “Status” is set to EX2. The upper line is the MSB, and the lower line is the LSB. This setting has no effect if “Status” is other than EX2.

OSC

These parameters specify how each MIDI track will be sounded.

Force OSC Mode [PRG, Poly, MN, LGT]

This lets you override the Program’s stored Voice Assign Mode settings, if desired.
For more information, please see “OSC Mode” on page 39.

OSC Select [BTH, OS1, OS2]

Specifies whether the MIDI track’s program will play OSC1, OSC2, or both.

For programs whose Oscillator Mode (p.82) is Double, this setting lets you specify that only OSC1 or OSC2 will sound.

BTH (Both): OSC1 and 2 will sound as specified by the settings of the program.

OS1: Only OSC1 will sound.

OS2: Only OSC2 will sound. PCM programs will not sound if “Oscillator Mode” is set to Single or Drums.

Portamento [PRG, Off, 001...127]

Make portamento settings for each MIDI track. For more information, please see “Portamento” on page 39.

Pitch/Other



Here, you can make pitch, scale, and delay time from note-on settings for each track.

Track 01...16 (Track Number)

Pitch

Transpose [-60...+00...+60]

Adjusts the pitch of each MIDI track in semitone steps.

12 units equal one octave.

For more information, please see "Transpose" on page 39.

Detune [-1200...+0000... +1200]

Adjusts the pitch of each MIDI track in one-cent units.

For more information, please see "Detune" on page 39.

Bend Range [PRG, -24...+00...+24]

Specifies the amount of pitch change that will occur when the pitch bender is operated, in semitone units.

For more information, please see "Bend Range" on page 39.

Delay

This specifies the time (delay) from when the MIDI tracks 1–16 receive a note-on message until the sound begins.

Track 01...16 (Track Number):

Delay Time [ms] [0000...5000ms, KeyOff]

Specifies the time (delay time) from note-on until the MIDI track begins to produce sound, in units of ms (1/1000th of a second). This setting is available if "MIDI/Tempo Sync." is set to Off.

KeyOff: The note will begin sounding at note-off. In this case, the sound will not die away if the sustain level of the program's amp EG is other than 0. This setting is used when creating harpsichord sounds.

Normally you will set this to 0000.

Tempo Sync (MIDI/Tempo Sync) [Off, On]

The time (delay time) from note-on until the track produces sound will be specified in note length units relative to the ♩ (Tempo).

On: Specify the delay time in terms of a Base Note and Times relative to the Tempo. For example if "Base Note" = ♩, "Times" = 01, and "Tempo" = 60 BPM, the delay time will be equivalent to 1000 ms.

Off: The delay time will be set by the Delay Time setting.

Base Note [♪, ♩, ♪, ♫, ♮, ♯, ♭, ♮, ♯, ♭, ♮, ♯, ♭, ♮, ♯, ♭, ♮]

Note Times [01...32]

It specifies the time (delay time) from note-on until the track begins to produce sound, in terms of a note value relative to the ♩ (Tempo).

Use Base Note to specify the desired note value, and use Times to extend that note value by the specified multiple.

For example if you set Base Note to a quarter note (♩) and Times to 02, that track will sound with a delay of a half note (♪). Even if you change ♩ (Tempo), the delay time will always be a half note (♪). If you use these parameters to specify a delay of a half note (♪). In this case, a Tempo of 60.00 BPM will produce a 2000 ms delay, and a Tempo of 120.00 BPM will produce a 1000 ms delay.

Other

Here, you can adjust the settings for the scale for each MIDI track.

Use Prog Scale [Off, On]

MIDI track can use the scale that is specified by Scale (p.82).

On: The scale specified by the program will be used.

Off: The scale specified by Scale will be used.

Tone

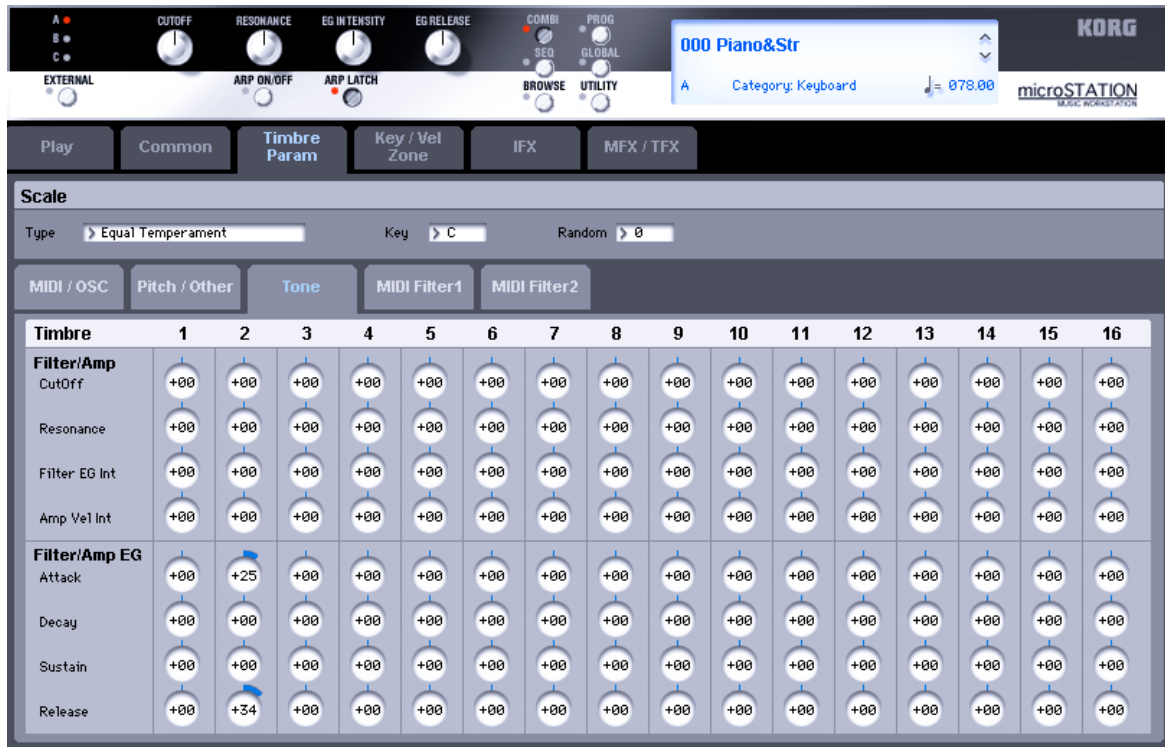

Here you can adjust the sound of the program for each MIDI track. The adjustments will not affect the original programs, but will be saved for each song. For more information, please see “About the Tone parameters” on page 149.

Track 01...16 (Track Number)

Filter/Amp

- Cutoff** [-99...+99] (Rel, CC#74)
- Resonance** [-99...+99] (Rel, CC#71)
- Filter EG Int** [-99...+99] (Rel, CC#79)
- Amp Vel Int** [-99...+99] (Rel)

See “Filter/Amp:” on page 39.

Filter/Amp EG

- Attack** [-99...+99] (Rel, CC#73)
- Decay** [-99...+99] (Rel, CC#75)
- Sustain** [-99...+99] (Rel, CC#70)
- Release** [-99...+99] (Rel, CC#72)

See “Filter/Amp EG:” on page 39.

MIDI Filter 1



These settings allow you to apply filters to the MIDI data that will be transmitted and received by each track. For more information, please see “MIDI Filter” on page 22.

Track 01...16 (Track Number)

Program Change	[Off, On]
After Touch	[Off, On]
Damper	[Off, On]
Portamento SW	[Off, On]
JS X as AMS	[Off, On]
JS+Y	[Off, On]
JS-Y	[Off, On]
Ribbon (CC#16)	[Off, On]
Foot SW	[Off, On]
Foot Pedal	[Off, On]
Other CC	[Off, On]

See “MIDI Filter:” on page 40.

MIDI Filter 2



These are MIDI filter settings for the knobs when the REAL-TIME CONTROL SELECT button is used to select Realtime Control A mode or B mode.

Use the Common-Controllers page to assign the functions that knobs 1-4 will perform when Realtime Control B mode is selected.

Track 01...16 (Track Number)

RTC Knob A1 [Off, On]
RTC Knob A2 [Off, On]
RTC Knob A3 [Off, On]
RTC Knob A4 [Off, On]

These settings enable or disable reception of the MIDI messages assigned to knobs 1-4 when the Realtime Control A mode is selected.

RTC Knob B1 [Off, On]
RTC Knob B2 [Off, On]
RTC Knob B3 [Off, On]
RTC Knob B4 [Off, On]

These settings enable or disable reception of the MIDI messages assigned to knobs 1-4 when the Realtime Control B mode is selected.

Key/Vel Zone (Keyboard/Velocity Zone)

K/V Zone	1	2	3	4	5	6	7	8	9	10	11	12	13	14	15	16
Top Key	G9	G9	G9	G9	G9	G9	G9	B3	G9	G9	G9	G9	G9	G9	G9	G9
Bottom Key	C-1	C-1	C-1	C-1	C-1	C-1	C-1	C-1	C-1	C-1	C-1	C-1	C-1	C-1	C-1	C-1
Top Slope	> 0	> 0	> 0	> 0	> 0	> 0	> 0	> 0	> 0	> 0	> 0	> 0	> 0	> 0	> 0	> 0
Bottom Slope	> 0	> 0	> 0	> 0	> 0	> 0	> 0	> 0	> 0	> 0	> 0	> 0	> 0	> 0	> 0	> 0
Top Velocity	127	127	127	127	127	127	127	127	127	127	127	127	127	127	127	127
Bottom Velocity	001	001	001	001	001	001	001	001	001	001	001	001	001	001	001	001
Top Slope	> 0	> 0	> 0	> 0	> 0	> 0	> 0	> 0	> 0	> 0	> 0	> 0	> 0	> 0	> 0	> 0
Bottom Slope	> 0	> 0	> 0	> 0	> 0	> 0	> 0	> 0	> 0	> 0	> 0	> 0	> 0	> 0	> 0	> 0

Keyboard Zone

Here, you can specify the key zones in which MIDI tracks 1–16 will sound.

For more information, please see “Key Zone:” on page 40.

Track 01...16 (Track Number):

Top Key [C-1...G9]

Specifies the top key (upper limit) of the notes that will sound for each MIDI track.

Top Slope [00, 01, 02, 03, 04, 06, 08, 10, 12, 18, 24, 30, 36, 48, 60, 72]

Specifies the range of keys (12 is one octave) over which the volume will be reached starting from the top key.

Bottom Slope [00, 01, 02, 03, 04, 06, 08, 10, 12, 18, 24, 30, 36, 48, 60, 72]

Specifies the range of keys (12 is one octave) over which the volume will be reached starting from the bottom key.

Bottom Key [C-1...G9]

Specifies the bottom key (lower limit) of the notes that will sound for each MIDI track.

Key Zone Map

This area indicates the note ranges in which each MIDI track (1–16) will sound.

The display uses lines to indicate the range of notes that will sound, and show the slope portion in a different color.

Velocity Zone

Here, you can set the Top/Bottom Velocity parameters to specify the range of velocities that will be sounded by MIDI tracks 1–16, and Top/Bottom Slope specify the range over which the volume will be adjusted.

For more information, please see “Vel Zone (Velocity Zone):” on page 40.

Track 01...16 (Track Number):

Top Velocity [1...127]

Specifies the maximum velocity value that will sound each track.

Top Slope [0...120]

Specifies the number of velocity steps over which the original volume will be reached, starting from the Top Velocity.

Bottom Slope [0...120]

Specifies the number of velocity steps over which the original volume will be reached, starting from the Bottom Velocity.

Bottom Velocity [1...127]

Specifies the minimum velocity that will be sounded by each MIDI track 1–16.

Vel Zone Map

This area indicates the velocity ranges in which each MIDI track (1–16) will sound.

The display uses lines to indicate the velocity of notes that will sound, and show the slope portion in a different color.

IFX (Insert Effect)

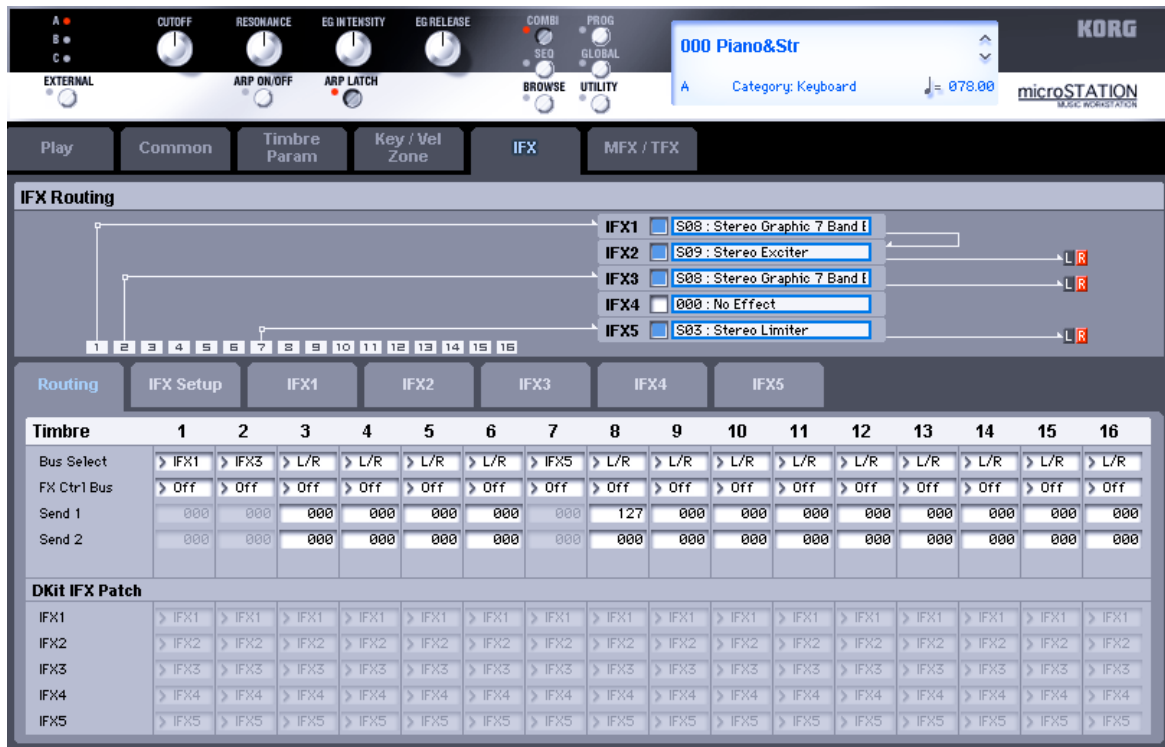

In this page you can adjust the settings for the insert effects. These settings consist mainly of the following.

- Specify the routing for each track.
- Select the effect type for insert effects 1–5, and edit the effect parameters.
- Specify on/off and chain settings for insert effects 1–5.
- Adjust mixer settings following the insert effects.

For more information, please see “IFX1, IFX2, IFX3, IFX4, IFX5” on page 46.

IFX Routing

This area shows the insert effect routing (Bus Select), the name of the assigned effect, the on/off status, chaining, and the output bus that follows the insert effect.

The type of insert effect, the on/off status, and the chain settings can be edited in the IFX Setup page.

IFX1 On/Off	[Off, On]
IFX2 On/Off	[Off, On]
IFX3 On/Off	[Off, On]
IFX4 On/Off	[Off, On]
IFX5 On/Off	[Off, On]

IFX1	[S00...S63, D00...D10]
IFX2	[S00...S61, D00...D09]
IFX3	[S00...S61, D00...D09]
IFX4	[S00...S61, D00...D09]
IFX5	[000...061]

See “IFX Routing” on page 129.

Routing

Specifies the bus where the program oscillator(s) used by MIDI tracks 1–16 will be sent. You can also set the send levels to the master effects from this page.

Track 01...16 (Track Number)

Bus Select [DKit, L/R, IFX1...5, Off]

This specifies the output bus for the track program’s oscillator(s).

See “Bus (Bus Select)” on page 155.

FX Control Bus [Off, 1, 2]

This parameter specifies the MIDI channel that will be used to control effect dynamic modulation (Dmod), pan following the insert effect (CC#8), Send 1, and Send 2.

For more information, please see “Ctrl Ch (Control Channel)” on page 25.

Send1 (MFX1) [000...127]

Send2 (MFX2) [000...127]

For each track, these parameters set the send level to master effects 1 and 2. See “Send1” on page 19.

DrumKit IFX Patch

IFX1	[L/R, IFX1...IFX5, Off]
IFX2	[L/R, IFX1...IFX5, Off]
IFX3	[L/R, IFX1...IFX5, Off]
IFX4	[L/R, IFX1...IFX5, Off]
IFX5	[L/R, IFX1...IFX5, Off]

This patches the “Bus (IFX/Output)” settings for each key of a drum kit, temporarily changing the insert effect connection destinations. See “DrumKit Patch” on page 19.

IFX Setup



Here you can choose the type of each insert effect 1 through 5, its on/off status, chaining, and adjust the post-IFX mixer settings.

For more information, please see “IFX Setup” on page 155.

IFX1

Chain To	[IFX2...IFX5]
Chain	[Off, On]
Pan	[L000...C064...R127]
Bus (Bus Select)	[Off, L/R]
FX Control Bus	[Off, 1, 2]
Send1	[000...127]
Send2	[000...127]

See “IFX1, IFX2, IFX3, IFX4, IFX5” on page 11.

Control Ch [Ch1...16, Global Channel, All Routed]

This parameter specifies the MIDI channel that will be used to control effect dynamic modulation (Dmod).

For more information, please see “FXCtrl Bus (FX Control Bus)” on page 25.

IFX2, IFX3, IFX4, IFX5

Here you can edit the effect parameters for insert effects 2–5 selected in the IFX Routing. The parameters are the same as in insert effect 1.

IFX1



Here, you can set the effect parameters of the insert effect you chose in the IFX Routing.

IFX1 Parameters

IFX Parameters

Here you can edit the effect parameters for the insert effect. For more details, please see "Effect Guide" on page 205.

IFX2, IFX3, IFX4, IFX5

Here you can edit the effect parameters for insert effects 2–5 selected in the IFX Routing. The parameters are the same as in insert effect 1.

For more details, please see "Effect Guide" on page 205.

MFX/TFX (Master/Total Effect)



In this page you can adjust the settings for the master effects and the total effect. These settings consist mainly of the following.

- Specify the routing for the master effects.
- Select the effect type for the master effects and the total effect, and edit the effect parameters.
- Turn each effect on/off.
- Edit the return level to the L/R bus for the master effect outputs.

MFX&TFX Routing

Here you can specify the type of master effects and total effect, and turn them on/off.

The master effects are sent to the L/R bus. The total effect is inserted into the L/R bus.

These parameters are the same as in Program mode.

MFX1, MFX2

Here, you can select the settings for the master effect 1, 2.

On/Off [Off, On]
MFX [S00...S87, D00...D13]
MFX2 [000...120]

Return1, Return2

Return 1 [000...127]
Return 2 [000...127]

See “MFX&TFX Routing” on page 134.

TFX

TFX On/Off [Off, On]
TFX [00...61]

See “MFX&TFX Routing” on page 134.

Master Volume

Master Volume [000...127]

This specifies the final level of the audio output that has passed through total effect, and output from OUTPUT L/MONO and R.

Routing

Chain

Master FX Chain [Off, On]
Level [000...127]

See “Chain” on page 135.

Control Channel

MFX1 [1...16, Global Channel]
MFX2 [1...16, Global Channel]
TFX [1...16, Global Channel]

Specifies the MIDI channel that will control dynamic modulation (Dmod) for the master and total effect.

Ch01...Ch16: The specified MIDI channel will be used for control.

MFX1



Here you can edit the parameters of the effect you choose for MFX1 in the MFX/TFX Routing.

MIDI Effect dynamic modulation (Dmod) is controlled on the global MIDI Channel "Channel" (p.184). For more information, please see "Dmod List (Dynamic Modulation Source List)" on page 292.

MFX1 Parameters

Here, you can edit the parameters of the master effect selected in the MFX/TFX page.

For more information, please see "Effect Guide" on page 205.

MFX2

These pages let you edit the parameters of Master Effect 2. To select different effects types, use the MFX/TFX Routing. The parameters for MFX2 is the same as for MFX1.

TFX

These pages let you edit the parameters of TFX. To select different effects types, use the MFX/TFX page. The parameters for TFX is the same as for MFX2.

UTILITY Command

Procedure for utility commands

1. Click the UTILITY button, and choose a command from the menu that appears.
2. Adjust the settings in the dialog box.
For details on the contents of each dialog box, refer to the explanation for each command.
3. Click the OK button to begin, or click the Cancel button if you decide not to continue.

Write SEQ

This command saves the edited song. You can use this to do the following things:

- Save the changes you've made in microSTATION Editor / Plug-In Editor.
- Rename the song.
- Copy the song to a different number.

New Name [characters]

Specify the song name.

Choose Destination [S000...127: name]

Specify the save-destination for the song.



“Choose Destination” only allows you to select an existing song as the save-destination. If you want to save a new song, click the BROWSE button, choose the desired number in the song list that appears, create a new song, and save that number.

Rename Song

Here, you can rename the selected song. A name of up to 24 characters can be input.

Delete Song

This command deletes the currently selected song.

For more information, please see “Delete (Delete Song)” on page 48.

Delete Song is available on the Quick, Common, Track Param, Key Zone/Vel Zone pages.

Copy From Song

This command copies all of the setting data and musical data from the specified song to the song that's currently selected.

For more information, please see “Delete (Delete Song)” on page 48.

Copy From Song is available on the Quick, Common, Track Param, Key Zone/Vel Zone pages.

GM Initialize

This command transmits a GM System On message to the Sequencer mode, resetting all tracks to the GM settings.

For more information, please see “GM Initialize” on page 49.

GM Initialize is available on the Quick, Common, Track Param, Key Zone/Vel Zone pages.

Copy From Combi (Copy from Combination)

This command copies the parameters of the specified combination to the setting data of the song that's currently selected.

For more information, please see “Copy Combi (Copy from Combination)” on page 50.

Copy From Combi is available on the Quick, Common, Track Param, Key Zone/Vel Zone pages.

Copy from Program

This command copies settings from the program you specify to the song that's currently selected.

For more information, please see “Copy Prog (Copy from Program)” on page 51.

Copy From Program is available on the Quick, Common, Track Param, Key Zone/Vel Zone pages.

Copy Arpeggiator

This command can be used to copy arpeggio settings from another location to the current program.

For more information, please see “Copy ARP” on page 48.

Copy Arpeggiator is available on the ARP tab of the Quick page and Common page.

Copy Insert Effect

This command copies effect settings from a specified program, combination, or song.

However, the “Ch (Control Channel)” setting is not copied. For more information, please see “Copy IFX” on page 14.

Copy Insert Effect is available on all of the IFX pages.

Swap Insert Effect

This command swaps (exchanges) the settings of two insert effects.

However, the “Ch (Control Channel)” setting is not swapped.

For more information, please see “Swap IFX” on page 14.

Swap Insert Effect is available on all of the IFX pages.

Copy MFX/TFX

This command copies effect settings from a specified program, combination, or song.

However, the “Ch (Control Channel)” setting is not copied. For more information, please see “Copy MFX/TFX” on page 14.

Copy MFX/TFX is available on all of the MFX/TFX pages.

Load

Loads microSTATION Editor/Plug-In Editor data that was previously saved on the computer.

Save

Saves data from the microSTATION Editor/Plug-In Editor to your computer as dedicated file.

All Data (.MSTall): All data (program, combination, song settings, global settings).

All SEQ (.MSTasq): All song settings data.

SEQ (MSTsq): A song settings data that's currently selected.

Note: These functions load or save the data as dedicated files for the editor application.

Receive All

Receives all data from the microSTATION data into the editor.

Note: The sequencer performance data of Sequencer mode is excepted.

Transmit All

Transmits all data in the microSTATION Editor/Plug-In Editor to the microSTATION and writes it into internal memory.

Receive SEQ

Receive the corresponding song data from the microSTATION into the microSTATION Editor/Plug-In Editor.

Transmit SEQ

Transmit the corresponding song data from the microSTATION Editor/Plug-In Editor to the microSTATION and writes it.

Receive 1 SEQ

Receive the respective song data from the microSTATION into the microSTATION Editor/Plug-In Editor.

Transmit 1 SEQ

See "Transmit Current Prog" on page 138.

Import

See "Import" on page 138.

Export

See "Export" on page 138.

All Sound Off

Depending on the host application, "hung" notes may sometime occurred while operating the host's functions. If this symptom occurs, please execute this command.

Global mode

By connecting the microSTATION to your computer and using microSTATION Editor / Plug-In editor, you'll be able to edit all of the microSTATION's parameters.

This chapter explains the parameters that you can view and edit in microSTATION Editor / Plug-In Editor. For details on how to select a parameter and modify its value, refer to the "microSTATION Editor / Plug-In Editor User's Guide" included on the accessory disc.

 For some of the parameters shown in microSTATION Editor / Plug-In Editor, the setting of the microSTATION itself is displayed in gray, and cannot be edited in microSTATION Editor / Plug-In Editor.

Page structure

Panel / Page	Main content
Software Setup	Start-up settings for microSTATION Editor / Plug-In Editor.
Basic/Controllers	Basic overall settings. (☞p.182) Controller settings such as the pedals connected to the rear panel. (☞p.183) CC# assignments for Arpeggio controllers. (☞p.183)
MIDI	MIDI settings for this instrument. (☞p.184) External Mode settings. (☞p.185)
User Scales	Scale settings created by the user. You can specify 4 types of octave scale, and one full-range scale. (☞p.186)
Category	Edit tab category names for programs and combinations. (☞p.187)
Drum Kit	Edit drum kits. (☞p.188)
Arpeggio Pattern	Creating Arpeggio pattern. (☞p.195)

Panel



The microSTATION Editor's panel lets you do the following things.

- Select programs and adjust the tempo.
- Switch the realtime control mode, and use the knobs to edit in each mode.
- Use the external control knobs.
- Turn the arpeggiator on/off and arpeggiator latch on/off.

In Global mode, only Realtime Control C mode is available when editing the arpeggio pattern in the Arpeggio Pattern page.

EXTERNAL button [Off, On]

Pressing this button will switch to external control, allowing you to use the knobs to control an external MIDI device or computer application.

Mode Select, UTILITY

Mode button [PROG, COMBI, SEQ, GLOBAL]

Click a button to select the mode that you want to edit.

UTILITY button

The utility functions are various commands available in each page. The available utility commands will differ depending on the page. These commands also let you save or load the edited or created data on your computer, and to import system exclusive data. Click the UTILITY button and choose a command from the menu that appears.

"UTILITY Command" on page 202

Arpeggiator

In Global mode, the arpeggiator buttons are available only when editing an arpeggio pattern.

ARP ON/OFF button [Off, On]

This turns the arpeggiator on/off.

ARP LATCH ON/OFF button [Off, On]

This turns the arpeggiator's Latch function on/off. If this is on, the arpeggio will keep playing even after you take your hands off the keyboard while the arpeggiator is running.

Display

Display shows the contents of the mode you had selected before entering Global mode.

Tempo [040.00...300.00]

This indicates the tempo.

When editing the arpeggio pattern in the Arpeggio Pattern page, you can use Realtime Control C mode knob 4 to adjust the playback tempo.

Realtime Controls

Select button [A, B, C]

These buttons select the realtime control mode.

In Global mode, selecting A mode or B mode and operating the knobs will not do anything. Only C mode will be available when editing the arpeggio pattern in the Arpeggio Pattern page.

Realtime Control Knob 1...4

These knobs control the functions that are assigned for each Realtime Control mode.

Software Setup



Global mode Software Setup lets you specify the default settings that the microSTATION Editor will use when it starts up. This setting is saved when you use the UTILITY command Save as Default, and will be remembered the next time you start up.

Total Recall & Data Sync Settings

Here you can specify the editor data that will be saved and loaded as part of the song data by your DAW software. This setting lets you save only the data you need. When the microSTATION Editor starts up, the types of data that you've checked here will also be loaded automatically from the microSTATION that's connected to your computer. (In other words, this data will be synchronized.) Since a data dump requires a certain amount of time, you may wish to shorten the startup time by using the Load Data File Automatically function instead of this function, or by using the UTILITY command Load to load a previously-saved data file into the microSTATION Editor.

Auto Load File

Load data file automatically at starting up

When the microSTATION Editor starts up, the data file that you specify here will automatically be loaded into the editor. After this process is completed, the data you checked in Total Recall & Data Sync Setting will be loaded via data dump.

Local Control

Auto Local Control

This setting automatically sets the microSTATION's Local Control setting to the appropriate state when you start up the editor. We recommend that you normally leave this parameter on. The microSTATION's Local Control setting will be reset to its original state when you close the editor.

MIDI Settings

Here you can adjust the settings for MIDI connections between the microSTATION Editor and the microSTATION.

MIDI IN Port / MIDI OUT Port

This selects the connection port for the microSTATION and the microSTATION Editor. The name of the currently connected MIDI port is shown. You won't need to change this setting if the microSTATION and the microSTATION Editor are connected correctly, since the microSTATION Editor will search for the microSTATION when it starts up, and will specify the MIDI port automatically.

Basic/Controllers

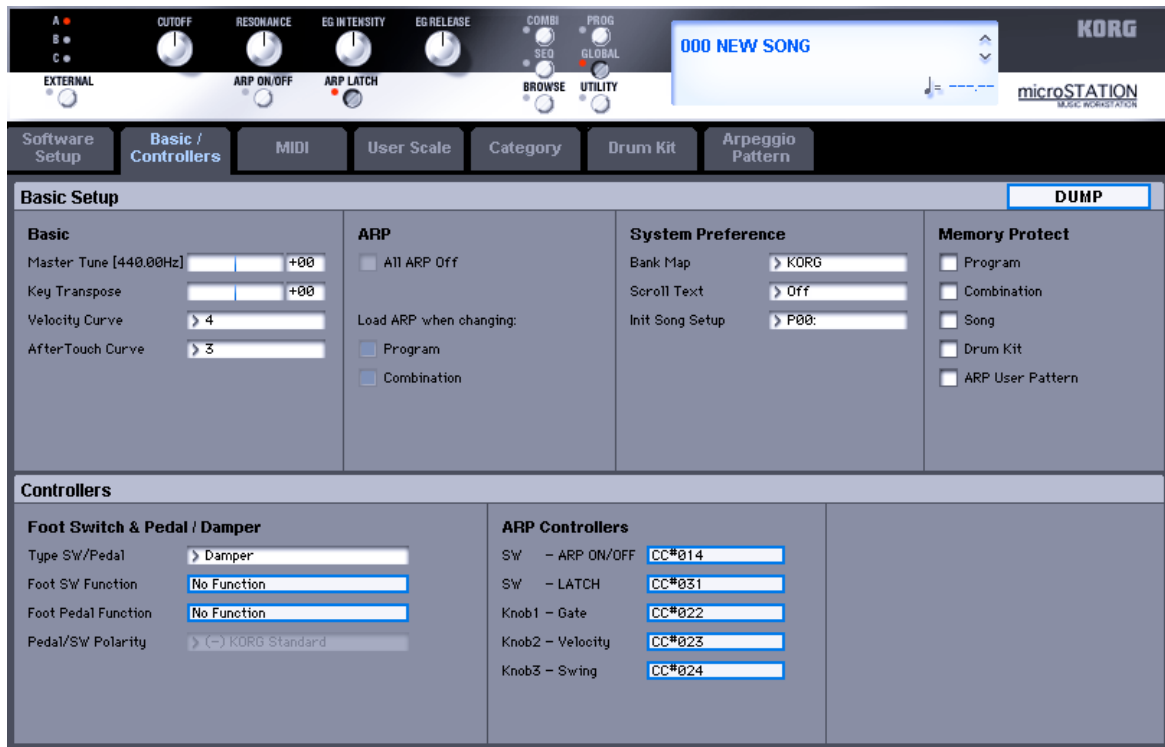

Settings in the Basic/Controllers – Category pages are remembered while the microSTATION Editor / Plug-In Editor is running, but will return to the settings prior to start-up when you close the microSTATION Editor / Plug-In Editor. By clicking the DUMP button located in the upper right of each Global mode page, the settings at that time will be saved on the microSTATION itself.

Basic Setup

Here, you can adjust master tune settings, on/off settings for the arpeggiator, bank map settings, and memory protect. The parameters is the same as for microSTATION Quick parameters.

Basic

Master Tune

[–50cent (427.47Hz)…+50cent (452.89Hz)]

This adjusts the overall tuning of the entire microSTATION in one-cent units (semitone = 100 cents), over a range of ±50 cents.

For more information, please see “MTune (Master Tune)” on page 57.

Key Transpose **[–12…+00…+12]**

This adjusts the pitch in semitone steps over a ±1 octave range.

For more information, please see “Transpose” on page 57.

Velocity Curve **[1…8]**

This specifies the way that the volume and/or tone will change in response to variations in keyboard playing dynamics (velocity).

For more information, please see “Vel Curve (Velocity Curve)” on page 57.

After Touch Curve (MIDI IN) **[1…8]**

This specifies the way that incoming aftertouch data will affect the volume or tone when Convert Position (p.184) is set to PostMIDI.

For more information, please see “AT Curve (Aftertouch Curve)” on page 59.

ARP

All ARP Off **[Off, On]**

All arpeggiator will be off.

For more information, please see “All ARP” on page 59.

Load ARP when changing: Program **[Off, On]**

When you switch programs, the arpeggiator settings stored in that program will be used.

For more information, please see “With Prog” on page 59.

Load ARP when changing: Combination **[Off, On]**

When you switch combinations, the arpeggiator settings stored in that combination will be used.

For more information, please see “With Combi” on page 59.

System Preference

Bank Map **[KORG, GM(2)]**

This specifies the mapping of programs and combinations relative to Bank Select control change messages (CC#0 upper byte and CC#32 lower byte).

For more information, please see “Bank Map” on page 59.

ScrollText **[Off, On]**

This specifies whether program names, combination names, and song names will be scrolled if they contain a larger number of characters than can be shown in the display.

For more information, please see “Initial Song” on page 60.

Initial Song**[P00...P15, U00...U15: name, Initialized Song]**

This selects the template song that will be loaded as the default song settings for Sequencer mode when the power is turned on.

For more information, please see "Initial Song" on page 60.

Memory Protect**Program [Off, On]**

This setting protects the internal program memory.

On: Internal program memory will be protected, and the following write operations cannot be performed.

- Writing a program
- Loading preloaded program data
- Loading program data from media
- Receiving program data via MIDI data dump

Off: Data can be written to internal program memory.

Combination [Off, On]

This setting protects the internal combination memory.

On: Internal combination memory will be protected, and the following write operations cannot be performed.

- Writing a combination
- Loading preloaded combination data
- Loading combination data from media
- Receiving combination data via MIDI data dump

Off: Data can be written to internal combination memory.

Song [Off, On]

This setting protects the internal song memory.

However, when the power is turned off, the song data in song memory will be lost regardless of this setting.

On: Internal song memory will be protected, and the following write operations cannot be performed.

- Recording to the sequencer
- Loading preloaded song data
- Loading song data from media
- Receiving song data via MIDI data dump

Off: Data can be written to internal song memory.

Drum Kit [Off, On]

This setting protects the internal drum kit memory.

On: Internal drum kit memory will be protected, and the following write operations cannot be performed.

- Writing a drum kit
- Loading preloaded drum kit data
- Loading drum kit data from media
- Receiving drum kit data via MIDI data dump

Off: Data can be written to internal drum kit memory.

ARP User Pattern [Off, On]

This setting protects the internal user arpeggio pattern memory.

On: Internal user arpeggio pattern memory will be protected, and the following write operations cannot be performed.

Writing a user arpeggio pattern

Loading preload arpeggio pattern data

Loading user arpeggio pattern data from media

Receiving user arpeggio pattern data via MIDI data dump

Off): Data can be written to internal user arpeggio pattern memory.

Controllers**Foot Switch & Pedal / Damper****Type [Damper, Switch, Pedal]**

This specifies the type of the switch or pedal that is connected to the DAMPER/PEDAL/SW jack.

For more information, please see "Type" on page 65.

Foot Switch function [List of Foot Switch Assign]

This is shown if "Type" is set to Switch.

For more information, please see "Sw (Foot Switch function)" on page 65.

Foot Pedal function [List of Foot Pedal Assign]

This is shown if "Type" is set to Pedal.

For more information, please see "Pdl (Foot Pedal function)" on page 65.

Damper/Switch Polarity [(-) KORG Standard, (+)]

Set this to match the polarity of the damper pedal or pedal switch that's connected to the DAMPER/PEDAL/SW jack.

For more information, please see "Polarity" on page 65.

ARP Controllers

Here, you can assign control change messages to the arpeggiator buttons and knobs 1–4 when realtime controls C mode is selected.

SW – ARP ON/OFF [Off, 000...119]**SW – LATCH [Off, 000...119]****Knob1 – GATE [Off, 000...119]****Knob2 – ARP VELOCITY [Off, 000...119]****Knob3 – ARP SWING [Off, 000...119]**

For more information, please see "ARP RTC CC#" on page 65.

MIDI



Here, you can adjust MIDI-related settings that affect the entire microSTATION.

The parameters is the same as for microSTATION Quick parameters. (☞ p.184)

MIDI

Basic

MIDI Channel (Global MIDI Channel) [1...16]

Sets the global MIDI channel. The global MIDI channel is used in the following cases.

For more information, please see “Channel (Global MIDI Channel)” on page 60.

Local Control On [Off, On]

Sets the local control on.

For more information, please see “Local Ctrl (Local Control)” on page 61.

Convert Position [PreMIDI, PostMIDI]

This setting specifies the location where the Transpose and Velocity Curve settings will be applied.

For more information, please see “Convrt (Convert Position)” on page 61.

Note Receive [All, Even, Odd]

This setting specifies whether even-numbered, odd-numbered, or all note numbers will be sounded when note data is received from the microSTATION’s keyboard or from an external MIDI device.

For more information, please see “Note Recv (Note Receive)” on page 61.

MIDI Clock**MIDI Clock**

[Internal, External MIDI, External USB, Auto]

Use this setting to synchronize the microSTATION’s arpeggiator and internal sequencer with an external MIDI device (e.g., sequencer or rhythm machine) and computer.

For more information, please see “Clock (MIDI Clock Source)” on page 62.

Receive Ext. Realtime Commands [Off, On]

The above Common messages (including Song Select) and Realtime messages will be received.

For more information, please see “Rcv ExtRTC (Receive Ext.Realtime Command Clock)” on page 62.

SEQ Mode**Track MIDI Out**

[for Master, for External Sequencer]

This setting specifies what will be transmitted via MIDI when you switch songs in Sequencer mode.

For more information, please see “Trk (Track MIDI Out)” on page 62.

Param. MIDI Out

[Control Change, SysEx-Param Change]

This setting specifies whether control changes or System Exclusive messages will be transmitted when you edit a parameter in Sequencer mode.

For more information, please see “Param (Parameter MIDI Out)” on page 62.

MIDI Out Routing

ARP Controllers

[Control Change, SysEx-Param Change]

This specifies the MIDI messages that will be transmitted when you operate the ARP ON/OFF button, ARP LATCH button, or when you operate knobs 1–4 with Realtime controls C mode selected.

For more information, please see “MIDI Out” on page 63.

MIDI Filter:

Enable Program Change [Off, On]

Program changes will be transmitted and received.

For more information, please see “Prog Chg (Enable Program Change)” on page 63.

Bank Change [Off, On]

The Bank Select control change message will be transmitted together with program change messages. This is valid when “Prog Chg” is turned on.

For more information, please see “Bank Chg (Enable Bank Change)” on page 63.

Combination Change [Off, On]

When in COMBI PLAY, an incoming program change message on the global MIDI channel set by “Channel” (p.60) will switch combinations.

For more information, please see “Combi Chg (Enable Combination Change)” on page 63.

Enable After Touch [Off, On]

MIDI aftertouch messages will be transmitted and received.

For more information, please see “AfterTouch (Enable Aftertouch)” on page 63.

Enable Control Change [Off, On]

Control change messages will be transmitted and received.

For more information, please see “Ctrl Chg (Enable Control Change)” on page 63.

Enable Exclusive [Off, On]

System exclusive data will be transmitted and received.

For more information, please see “SysEx (Enable System Exclusive)” on page 63.

External

The assignments you make in this external setup will determine the MIDI controller and MIDI channel that is transmitted by each knob when Realtime controls EXTERNAL is selected.

External setup names can be assigned only by using microSTATION Editor / Plug-In Editor. Use the Rename External Setup utility to assign a name.

External

Setup (External Mode Setup) [000...127: name]

This selects the External Setup to edit. You can assign a name to each setup.

Knob 1...4:

MIDI Channel [Ch01...16, Gch]

This sets the MIDI Channel for the knob. Each can send on a different channel, if desired.

For more information, please see “Channel” on page 64.

CC# [Off, 000...119]

This sets the MIDI CC sent by the knob.

For more information, please see “CC#” on page 64.

User Scale



Here, you can select the settings for four different User Octave Scales and one User All Notes Scale. The user scales you create here can be selected from the following pages.

- Prog: Basic-Scale
- Combi: Timbre Param-Scale
- Seq: Track Param-Scale

 If you want to keep the user scale you've specified, you must save it. Either use the utility command "Write Global Setting." or click the DUMP button located in the upper right.

User Octave Scale

User Octave Scale [User Octave Scale 00...03]

Selects the User Octave Scale that you want to edit.

Tune [-99...+99]

Adjusts pitch settings for each note in the octave.

When you adjust the pitch of each note in the octave (C-B) in one-cent steps, your settings will be applied to all octaves. This adjustment is relative to equal temperament.

A setting of -99 lowers the pitch approximately a semitone below normal pitch.

A setting of +99 raises the pitch approximately a semitone above normal pitch.

By using the utility command Copy Scale, you can copy settings from a preset scale (other than Stretch) or from another user scale.

User All Notes Scale

Tune [-99...+99]

Makes independent pitch settings for each of the 128 notes.

Adjust the pitch of each of the 128 notes (C-1 – G9) in one-cent steps. This adjustment is relative to equal temperament. A setting of -99 lowers the pitch approximately a semitone below normal pitch.

A setting of +99 raises the pitch approximately a semitone above normal pitch.

Use the horizontal scroll bar to move to the key range that you want to set, and select the key that you want to specify.

By using the utility command Copy Scale, you can copy settings from a preset scale (including Stretch) or another user scale.

Category



Programs, and Combinations are organized into sub-categories.

You can assign a Program or Combination to a category and sub-category during the utility command Write process.

 To save changes to sub-category names, you'll need to write the Global settings. To do so, use the utility command "Write Global Setting."

 The main category can not be edited, fixed.

Sub-Category Name

Mode:

Mode [Program, Combination]

Select the mode that includes the category you want to specify.

Main Category [00...17]

Select the main category that includes the sub-category whose name you want to specify.

Sub Category [00...07]

Select a sub-category, and specify its name. You can specify eight sub-categories for each category.

Drum Kit



Here, you can create drum kits by assigning a drum instrument (drum sample) to each key.

Drum kits can be created only by using microSTATION Editor / Plug-In Editor.

A drum kit you edit here can be used in the same way as a multisample oscillator (when "Oscillator Mode" is Single or Double) and processed through the filter, amp, and effects etc. To do this, set the "Oscillator Mode" to Drums in the microSTATION Editor/Plug-In Editor Program mode: Basic page, and selecting the drum kit as an oscillator in the OSC/Pitch- OSC1 Multisample page.

When you wish to edit a drum kit, enter Program mode, select a program that uses a drum kit (i.e., whose Oscillator Mode is Drums), and then move to this page. A program that uses a drum kit will already have filter, amp, and effect settings etc. suitable for drum sounds.

You must set "Octave" (p.80) to +0[8]. With any setting other than +0[8], the key locations and drum sounds will not correspond correctly.

Even if a program with an "Oscillator Mode" of Single or Double is selected in Program mode, the program will sound using its own filter and amp settings etc. Effects will sound according to the settings of the program you selected.

 Use "Write Drum Kits" to save an edited drum kit into the microSTATION itself. If you power-off the microSTATION before saving, the edited drum kit cannot be recovered. When you save, all drum kits will be saved. When you edit a drum kit, all programs that use that drum kit will be affected.

 Turn on "Sys Ex" into the microSTATION itself.

For detailed step-by-step instructions on creating drum kits, please see "Creating a Drum Kit" on page 192.

Drum Kit

Here, you can select a drum kit and specify High-Low (Drumsample 1-4) as the drum samples assigned to each key. Here, you can also edit drum sample parameters for each DS.

Drum Kit [00(INT)...47(USER)]

Selects the drum kit that you wish to edit.

No. (Bank)	Contents
00(INT)...26(INT)	Preloaded drum kits
27(USER)...47(USER)	User drum kits

Note: If you want to rename the drum kit, use the utility command "Rename Drumkit."

Key [C-1...G9]

Selects the key where the drum sample (and its settings) will be assigned.

Use the VALUE controller to specify the key. If "Key Chase" is checked, you can also select the key by holding down the KEY button and playing a note on the keyboard. You can assign four drum samples (DS1, 2, 3, 4) to each key, and switch between them by velocity.

If you turn "Assign" On, the key selected here will apply for the following drum sample parameters, velocity settings, Voice Assign Mode, and Mixer parameters.

Assign [Off, On]

On: The drum samples assigned by High-Low will sound. Normally you'll choose the On setting.

Off: The assigned drum samples will not be used; instead, the drum samples of the key to the right will sound, and their pitch will be a semitone lower than the key to the right. Choose the Off setting if you want to play drum samples at different pitches.

High Sample:

Specify the first drum sample.

On/Off [Off, On]

On: Check this if you want to use High. The selected drum sample will sound.

Off: DS1 (High) will not be used. The drum sample will not sound.

Normally, you will start by using DS1 (before using DS1–4). If you don't want to switch drum samples by velocity, turn on only DS1. If you're using multiple velocity-switched drum samples, adjust the settings as follows.

One velocity zone

DS1: On, DS2: Off, DS3: Off, DS4: Off

Two velocity zones

DS1: On, DS2: On, DS3: Off, DS4: Off

Three velocity zones

DS1: On, DS2: On, DS3: On, DS4: Off

Four velocity zones

DS1: On, DS2: On, DS3: On, DS4: On

Bank [Mono, Stereo]**Drumsample Select****[List of installed Drumsample]**

Specify the DS1 drum sample by bank and drum sample number.

Bank selects either Mono or Stereo drum samples. However, stereo drum samples will use twice as many voices as mono drumsamples.

Mono: Monaural drum samples.

Stereo: Stereo drum samples.

You can click "Drumsample Select" to open the drum sample list, and choose a drum sample from the list.

You can also click the Category ▼ button, specify a category from the menu that appears, and choose a drum sample from that category.

 It is not possible to edit the category names of drum samples, or to re-assign the category.

If you choose "Bank" Mono:

Mono drum samples will be displayed. The L-channel or R-channel of the stereo drum samples selectable via Bank: Stereo can also be selected as mono drum samples. In these cases, -L or -R is shown following the drum sample of the same name.

If you choose "Bank" Stereo:

Only stereo drum samples will be displayed.

Mid High Sample:**Mid Low Sample:****Low Sample:**

These are the settings for the second, third, and fourth velocity zones.

Sample Param

Here you can set each drum sample's sample parameters (transpose, tune, attack, decay, filter cutoff, resonance amount) and velocity zone. The sample parameter settings are added to the settings of the program.

High Sample

Here you can edit the sample parameters and velocity zone for the first drum sample (High).

Level [-99...+99]

Specifies the volume.

Keys for which a value of +99 is specified will sound at a volume twice as high as the amp level of the program which uses that drum kit. Keys for which a value of 0 is specified will sound at the volume of the amp level of the program which uses that drum kit. Keys for which a value of -99 is specified will not sound.

Start Offset [Off, 1st...8th]

In addition to simply starting playback from the beginning, drum samples can have up to 8 different pre-programmed alternate starting points. However, you can't select drum samples for which start and offset are not specified.

With drum samples, the "Start Offset" specifies whether to use the normal start point (Off), or to use one of the alternate start points (1st–8th).

Some drum samples may have fewer than 8 pre-programmed points, in which case only the available points can be selected.

Rev. (Reverse) [Off, On]

This lets you play the selected drum sample backwards, without looping. However, some preset drum samples cannot be reverse-played, and consequently, they cannot be selected.

On: The drum sample will play back in reverse.

The location at which reverse playback starts and ends is already specified for each drum sample.

Off: The drum sample will play back normally.

Transpose [-64...+63]

Adjusts the pitch in semitone steps. +12 is one octave up, and -12 is one octave down.

Tune [-99...+99]

This adjusts the pitch in cents, over a range of ±1 octave. A cent is 1/100 of a semitone.

Cutoff [-64...+63]

Adjust the cutoff frequency of the filter. The cutoff frequency for each key and drum sample is determined by adding this value to the filter "Frequency" (p.100) of the program that uses this drum kit.

Resonance [-64...+63]

This adjusts the filter resonance. This offset value for each key and drum sample is applied to the filter Resonance "Level" (p.101) of the programs that use this drum kit.

Attack [-64...+63]

Adjusts the attack time of the volume (Amplifier). The attack time for each key is determined by adding this value to the amp EG Attack Time of the program that uses this drum kit.

Decay [-64...+63]

Adjusts the decay time of the volume (Amplifier). The decay time for each key is determined by adding this value to the amp EG Decay Time of the program that uses this drum kit.

Bottom Vel. [1...127]

This sets the lowest velocity at which the drum sample will sound. High's Bottom Vel. can be equal to, but not lower than, than that of Mid High.

For example to create a simple setup that uses only one drum sample, specify the High settings, and then set "Bottom Vel." to 1 and "XFade Range" to off.

XFade Range [Off, 1...127]

This specifies the velocity range starting at "Bottom Vel." over which High will fade-out and Mid High will fade-in. For instance, if the "Bottom Vel." is set to 64, and the "XFade Range" is set to 20, Mid High will start to fade in at velocities of 84 and below.

When velocities are within the "XFade Range," the Oscillator will use twice as much polyphony as it would normally.

Note: You can only fade between two zones at once.

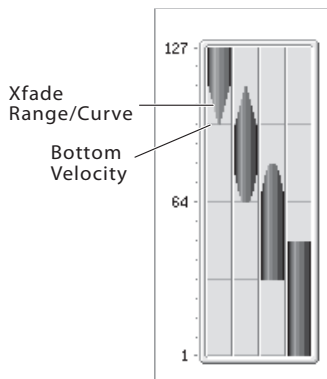

Crossfade Curves

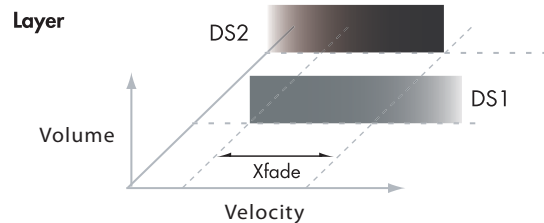
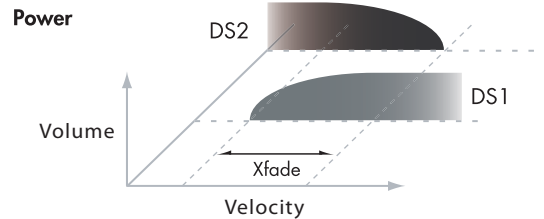
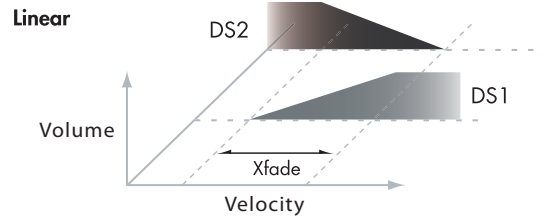

The graphic in the Velocity Split page shows the zone and crossfade settings.

XFade Curve [Linear, Power, Layer]

This controls the volume curve of the crossfade. Lin and Pwr (short for Equal Power) let you fine-tune the way that the two drum samples mix together; one or the other may be more appropriate for a given pair of drum samples. Lyr (Layer), true to its name, lets you layer the two drum samples together without any crossfading.

Lin(Linear) means that the two samples will each be at 50% of their full volume in the middle of the crossfade. Sometimes, this may create a dip in the volume level; if so, try using Pwr(Power) instead.

Pwr (Power), short for Equal Power, means that the two samples will each be at around 70% of their full volume in the middle of the crossfade. Sometimes, this may create a bump in the volume level, in which case you might try selecting Lin(Linear) instead.

Lyr (Layer) means that the two drum samples will be layered together, both at full volume, for the entire range of the crossfade.

Mid High Sample, Mid Low Sample, Low Sample

Here you can edit the sample parameters for the second, third, and fourth drum samples. Refer to "High Sample." The Mid High and Mid Low velocity zone settings are the same as for High. The settings for Low are similar to High, with the exception that Low does not have "Bottom Vel.," "XFade Range," and "XFade Curve" parameters. "Bottom Vel." is always fixed at 1.

Voice/Mixer



Specify the voice assign, pan, and effect routing etc. for each key of the drum kit.

Voice Assign Mode

Single Trigger [Off, On]

On: Even when the same key (note) is played repeatedly, the previous note will be halted before the new note is begun, so that the notes will not overlap. Normally you will leave this Off.

Exclusive Group [Off, 001...127]

001–127: This allows you to assign keys to any of 127 groups. Keys assigned to the same group will be treated as a single group, and will be played monophonically with last-note priority. For example you might assign closed and open hi-hat sounds to the same group so that two or more hi-hat sounds can not sound simultaneously.

Off: Keys will not be grouped. This is the default setting.

Enable Note On Recv [Off, On]

On: Note-on messages will be received. Normally you will On this, but you can Off it if you do not want specific notes to sound.

Enable Note Off Recv [Off, On]

On: Note-off messages will be received. Normally you will uncheck this. This parameter is valid when Hold (p.83) is On (Hold On). In the case of a drum program, you will normally select Hold On. In this case if "Enable Note Off Receive" is On, note-off messages will be received, and the sound will stop (the release segment of the EG will begin) when the key is released.

Mixer

 In Program mode, Drum kits will sound using the settings of the selected program. "Pan" is valid if "Use DKit Setting" (p.111) is On. "Bus (IFX/Output)," "FX Control Bus," and "Send 1/2" are valid if "Use DKit Setting" (p.130) is checked. Be aware that while editing a drum kit, the edited results will not be reflected unless these settings have been made.

Pan [RND, L001...C064...R127]

Specifies the panning for each key.

L001 places the sound at far left, and R127 places the signal at far right. With a setting of Random, the drum sample will be panned randomly at each note-on.

Bus (IFX/Output) [L/R, IFX 1...IFX5, Off]

For each key, specify the bus where the sound will be sent.

For example, you might send Snare sounds to IFX1 and Kick sounds to IFX2 to apply separate insert effects, and send the remaining sounds to L/R without applying insert effects.

Tip: In most of the preloaded drum kits, the following types of drum instrument have the same Bus (IFX/Output) settings.

Snares → IFX1

Kicks → IFX2

Other → IFX3

FX Control Bus [Off, 1, 2]

For each key, you can select whether the signal will be sent to FX Control bus (stereo two-channel) FX Ctrl1 or 2.

Normally you will leave this off, but you can use this setting if you want to control an effect by playing a specific key.

You can use this with the following effects:

Vocoders:

D09: Vocoder

Compressor and gate-type effects:

S03: St.Limitr

S06: St.Gate

Example: Limiter (Combination)

Compressor-type effects use the level of the audio input to control the level gain of the audio output.

For these effects, the envelope detection source can be either the audio input itself (the usual method) or FX Control Bus 1 or 2.

The example shown in the diagram is of a split combination in which the level of timbre 1 (Pad, played from the low key range) is being controlled by timbre 2 (Guitar, with IFX2 OD/Wah inserted, played from the high key range). You can adjust the settings so that when you play the guitar sound, the volume of the pad will decrease automatically. Send the post-IFX2 signal via FX Control Bus to FX Ctrl1, and set the IFX1: St.Limiter Envelope Source parameter to FX Control 1.

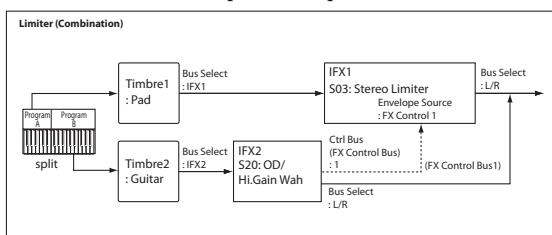

Send1 (to MFX1) [000...127]

Send2 (to MFX2) [000...127]

For each key, specify the send levels to master effects 1 and 2.

These settings are valid when “Bus (IFX/Output)” is set to L/R or Off. If “Bus (IFX/Output)” is set to IFX1–IFX5, the send level to master effects 1 and 2 will be determined by the Program, Combination, or Sequencer mode FX Routing page parameters Send1 and Send2 which are located after the sound passes through IFX1–IFX5.

Creating a drum kit

Use microSTATION Editor / Plug-In Editor if you want to create or edit a drum kit.

It's not possible to create or edit a drum kit on the microSTATION itself.

Before you start editing...

Drum Program selection

Drum Kits are edited in Global mode. While you're in Global mode, you'll play the kit that you're editing as if you were playing it from within the Program, Combination, or Song which was selected before you entered Global mode.

So, before you enter Global mode, it's best to select a Program which is already set up for drums, with the appropriate EG settings, effects, and so on. Just use the Program “Category select,” and choose a drum Program.

OSC1/Basic Octave setting

The Oscillator's Octave setting needs to be +0 [8']. All Drum Kit Programs should have this setting already. If you're unsure, you can check this yourself:

1. Access the PROG OSC/Pitch– OSC1 Common page.
2. Check that the “Octave” parameter (near the top of the page) is set to +0 [8'].
With a setting other than +0 [8'], the relationship between the keys and the Drum Kit sound map will be incorrect.

Make sure that Memory Protect is disabled

Before you start editing, go to the Global: Basic/Controllers page, and look in the Memory Protect section. Make sure that Drum Kit is not checked (protected)—if so, you won't be able to make any edits.

Drum Kits may be used by more than one Program

When you edit a Drum Kit, all Programs that use that Drum Kit will be affected. To avoid changing the factory voicing, you may wish to copy Drum Kits to empty locations in the USER banks before editing.

Backing up a Drum Kit

Global mode does not have a Compare function that returns the edited result to the state prior to editing. Before you begin editing a user Drum Kit, it's a good idea to use Copy Drum Kit to copy that Drum Kit to a vacant number.

Creating a Drum Kit

Specifying the key where you will assign a drum-sample

1. Select the Program that you wish to use while editing the Drum Kit.
2. Press the MODE GLOBAL button to enter Global mode.
3. Access the Global: Drum Kit– Sample Param page.
4. Use the Drum Kit parameter, at the top of the page, to select the Drum Kit that you wish to edit.

GM drum kits 48 (GM)–56 (GM) cannot be selected here. (It is not possible to edit or write a GM drum kit.) If you wish to modify the settings of one of the drum kits 48 (GM)–56 (GM), you can use Copy Drum Kit to copy it to 00 (INT)–26 (USER), and then edit the copy.

- Use the Key parameter to select the note that you wish to edit.
If “Chase On” is On, you can also hold down the KEY button and play a note on the keyboard.
- Use the “Assign” to specify whether the key will have its own settings, or use the same settings as the next higher note.
If “Assign” is On, the key will have its own settings. This is the default.
If “Assign” is Off, the key won’t have its own settings. Instead, it will use the same settings as the next higher note—except that the drumsamples will be played at a lower pitch. The amount of pitch change depends on the Pitch Slope parameter, on the Prog: OSC/Pitch– OSC Common page.

Creating a velocity crossfade

For this key, let’s create a simple velocity crossfade between two stereo drumsamples.

- On the left side of the page, make sure that High and Mid High are turned On.

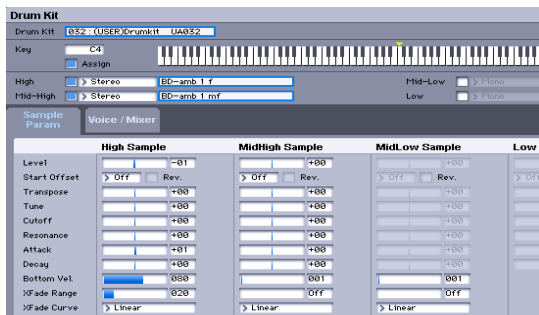

- Similarly, make sure that Mid Low and Low are turned Off.
- Select Stereo as the Bank for High and Mid High.
- Click the Drumsample for High.
A drum sample list organized by category will be displayed. The drum samples are organized into categories such as bass drum and snare.
You can click the upper ▼ button to view a list for a different category.
- Select a Drumsample by touching its name in the list. Press the OK button to confirm your selection.
- Do the same for Mid High.
Now that you’ve assigned Drumsamples to High and Mid High, let’s set up the velocity ranges and crossfades.
- Set Mid High’s Bottom Velocity to 001, and its Xfade Range to Off.
- Set High’s Bottom Velocity to 80.
Now, Mid High will sound when you play softly, at velocities of 79 or less—and High will sound when you play harder, with velocities of 80 or more.
- Next, set High’s Xfade Range to 20, and its Curve to Linear.
Notice that the graphic now shows the two ranges tapering into one another. Between 80 and 100, Mid High will fade out, and High will fade in, creating a gradual velocity transition instead of a hard split.

Fine-tuning the sound of each sample

- If you like, adjust the Levels for the two Drumsamples. This can be very useful in creating a smooth velocity split or crossfade.
- As necessary, specify the tuning, EG parameters, and filter.
- Adjust Tune, Attack (Amp EG Attack), Decay (Amp EG

Decay), Cutoff and Resonance for each drumsample.

- Repeat “Specifying the key where you will assign a drumsample” on page 192 to set up each key of the Drum Kit.
You can also copy settings from one key to another, using the Copy Key Setup utility command.

Using Exclusive Groups

- Access the Drum Kit– Voice/Mixer page.
- Use the Exclusive Groups to make one drum sound cut off another drum sound - such as closed and open hi-hats.
For example, let’s say that you’ve assigned an open hi-hat and a closed hi-hat to the same exclusive group: Play the open hi-hat sound.
While it’s still ringing, play the closed hi-hat.
The open hi-hat sound will be cut off—simulating the action of a physical hi-hat.

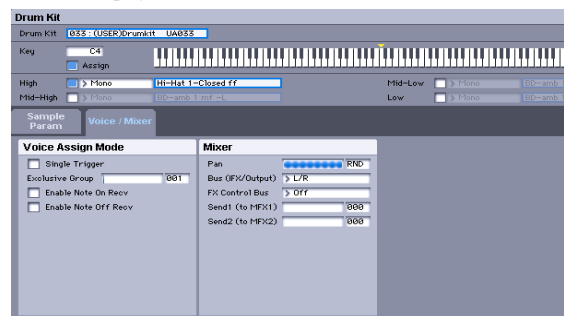

Using Hold

The Program Hold parameter can be especially useful for drum programs, since it lets the samples ring out naturally regardless of how long you hold down the note. The way that this works depends on settings in both the Program and the Drum Kit, as described below.

To enable Hold:

- Access the PROG: Basic page.
- Under Key Zone, make sure that the Hold check-box is checked.
Once you’ve turned on Hold for the Program, the function is controlled on a note-by-note basis according to settings within the Drum Kit.
- Access the Global: Drum Kit– Voice/Mixer page.
- For each key, set the Enable Note Off Receive parameter as desired.
If this parameter is Off, the key will be held.
If it is On, the key will not be held.
If you turn off Hold in the Program, no keys will be held - regardless of their Enable Note Off Receive setting.

Controlling effects for each key

Drum Kits have their own, built-in mixers. For each key, you can control the Insert Effects bussing, Master Effects sends, and pan.

To use separate bus settings for each key:

- Access the PROG: IFX page.
- Make sure that the “Use DKit Setting” is On.
When “Use DKit Setting is On,” the Program will use the Bus Select and Effects Send settings for each key of the Drum Kit.
When Use DKit Setting is off, the Program will ignore the Drum Kit’s Bus Select and Effects Send settings.
- Access the Global: Drum Kit– Voice/Mixer page.

Use the Bus (IFX/Output) Select parameter to send drum sounds through their own Insert effects, or to the L/R outputs.

If you like, you can send each note to its own Insert effect, or to the individual audio outputs, in addition to the L/R outputs.

For example, you might send all snare sounds to IFX1, all kick sounds to IFX2, and the remaining sounds to L/R.

Tip: In most preloaded drumkits, the drum instruments have the same Bus (IFX/Output) settings according to their type, as follows.

Snares → IFX1

Kicks → IFX2

Other → IFX3

4. Use “Send1 (to MFX1)” and “Send2 (to MFX2)” to set the send levels to the master effects.

Controlling pan for each key

To use separate pan settings for each key:

1. Access the PROG: Amp– Amp1 page.
2. Under Pan, make sure that the “Use DKit Setting” is On. When “Use DKit Setting” is On, the Program will use the pan settings for each key of the Drum Kit.
3. Access the Global: Drum Kit– Voice/Mixer page.
4. Use “Pan” to specify the panning for each key.

Saving Drum Kits

Once you’ve spent all this time editing, you’ll want to save your work.

The contents of your editing in Global mode are preserved as long as the power is on, but will be lost when you turn off the power. If you want to keep your edits, you must save by using the Write Drum Kits function.

This will save all drum kits.

Arpeggio Pattern



Here, you can create user arpeggio patterns.

In this page, the microSTATION will continue to sound as it did before entering Global mode.

If you entered Global mode from Program mode: Your editing will apply to the arpeggio pattern that is selected by the program. Even if the previously selected program's arpeggiator is turned off, it can be turned on by the ARP ON/OFF button.

If you entered Global mode from Combination mode: Your editing will apply to the arpeggio pattern that is selected by the combination. Even if the previously selected combination's arpeggiator is turned off, it can be turned on by the ARP ON/OFF button.

However, it is not possible to turn on an arpeggiator for which the Arpeggiator "Run" (p.143) parameter A or B is Off. Additionally, the arpeggiator will not operate if it has not been assigned to a timbre in "Arpeggiator Assign" (p.143).

If you entered Global mode from Sequencer mode: Your editing will apply to the arpeggio pattern specified for the selected song. Even if you entered Global mode from settings in which the arpeggiator was turned off, you can use the ARP ON/OFF button to turn it on.

However, it is not possible to turn on an arpeggiator for which the Arpeggiator "Run" (p.164) parameter A or B is not checked. Additionally, the arpeggiator will not operate if it has not been assigned to a track in "Arpeggiator Assign" (p.164).

In each of the above cases, you can modify the settings of the arpeggio pattern even if the arpeggiator is not turned on. When editing a pattern, it is a good idea to turn on the arpeggiator and make sure that it is the pattern that you wish to edit.

 If you want the edited user arpeggio pattern settings to be backed up even when the power is turned off, you must write them into memory. Select the Write Arpeggio Pattern utility command to access the Write Arpeg-

gio Pattern dialog box. Then press the OK button to write the edited data.

For details on creating an arpeggio pattern, see page 246.

Common

Arpeggiator Select [A, B]

If the microSTATION was previously in Combination or Sequencer mode and you want to edit an arpeggio pattern, you must select either arpeggiator A or B as the pattern to edit. Your editing will apply only to the selected one. B will not be displayed if the previous mode was Program mode.

Pattern

[P0: UP...P4: RANDOM, U000(INT)...U511(INT), U512(USER)...U639(USER): name]

Selects the pattern that you want to edit.

P0: UP...P4: RANDOM	Preset arpeggio patterns
U000(INT)...U511(INT)	Preloaded arpeggio patterns
U512(USER)...U639(USER)	User arpeggio patterns

Note: If you want to edit an arpeggio pattern (such as a preloaded arpeggio pattern) that is also used by another program, it is a good idea to use the utility command Copy Arpeggio Pattern to copy the arpeggio pattern to an unused number U512(USER)...U639(USER), and then to edit the copy.

Note: If you want to edit the arpeggio pattern name, use the utility command Rename Arpeggio Pattern.

Length [01...48]

Specifies the length of the arpeggio pattern. The arpeggio pattern will play the number of steps you specify here at the

note value interval specified by "Resolution," and will then begin again. This is not valid for preset arpeggio patterns P0-P4.

Resolution	[♪♩, ♪, ♪♩, ♪♩, ♪♩, ♪♩]
Octave	[1, 2, 3, 4]
Sort	[Off, On]
Latch	[Off, On]
Key Sync.	[Off, On]
Keyboard	[Off, On]

See "ARP Setup" on page 9.

 "Pattern," "♪ (Tempo)," "Octave," "Resolution," "Sort," "Latch," "Key Sync.," and "Keyboard" are parameters that can be set in Program, Combination, and Song, but you can also set them here.

If you move here from Program or Combination mode and set these parameters, you must return to the original mode and write them. These parameters cannot be written by the "Write Arpeggio Patterns" command in this page.

Setup

 These parameters are not valid for preset patterns P0-P4.

Arpeggio Tone Mode [Normal, Fixed Note]

This selects the Tone type of the arpeggio pattern.

Normal: This is the conventional arpeggiator type. Each Tone in the arpeggio will play based on the note number of the keys that you are pressing on the keyboard.

Fixed Note: The note number of each tone is fixed. The note numbers played on the keyboard will be ignored, and the arpeggio will sound using specified pitches. Note numbers from the keyboard will only control the trigger timing of the arpeggiator. Fixed Note mode is ideal for arpeggio patterns that you are using as drum patterns.

In the Edit, the Tone indicators will be "■" when Normal is selected here, or "□" when Fixed Note is selected.

Arpeggio Type [As Played...Up&Down]

Specifies the relationship between the arpeggio notes specified from the keyboard and the Tone at each step.

As Played: If there are more Tones in a step than arpeggio notes specified (notes played on the keyboard), those steps will not sound.

As Played (Fill): If there are more Tones in a step than arpeggio notes specified (notes played on the keyboard), the last-played note (Sort is Off), or the highest note (Sort is On) will sound for those steps.

Running Up: If there are more Tones in a step than arpeggio notes specified (notes played on the keyboard), the arpeggio will return to the first note (if Sort is Off), or the lowest note (if Sort is On) and sound it.

Up&Down: If there are more Tones in a step than arpeggio notes specified (notes played on the keyboard), the arpeggio will return in reverse direction from the last arpeggio note back toward the first.

Example

If you set Length to 04, Step No. 01 to Tone0, Step No. 02 to Tone1, Step No. 03 to Tone2, Step No. 04 to Tone3, and simultaneously play three notes to produce an arpeggio, the following results will be produced depending on the Arpeggio Type.

As Played: 0 → 1 → 2 → rest → 0 → 1 → 2 → rest → 0 ...

As Played (Fill): 0 → 1 → 2 → 2 → 0 → 1 → 2 → 2 → 0 ...

Running Up: 0 → 1 → 2 → 0 → 0 → 1 → 2 → 0 → 0 ...

Up&Down: 0 → 1 → 2 → 1 → 0 → 1 → 2 → 1 → 0 ...

Octave Motion [Up, Down, Both, Parallel]

Specifies the operation when "Octave" is set to 2-4 octaves.

Up: Notes will repeatedly ascend within the specified range of octaves.

Down: Notes will repeatedly descend within the specified number of octaves.

Both: Notes will repeatedly ascend and descend within the specified number of octaves.

Parallel: The notes of the specified octaves will sound simultaneously.

Fixed Note

Fixed Note Mode [As Played, All Tones]

When the Arpeggio Tone Mode is Fixed Note, specifies the condition that will trigger the Tones.

Trigger As Played: The Tones will be triggered according to the number of keys pressed.

Trigger All Tones: Pressing a single key will trigger all Tones.

Example

We will use an Arpeggio Tone Mode Fixed Note pattern on drums. Tone 0 is assigned a note number that will sound a kick, Tone 1 a snare, and Tone 2 a hi-hat.

With a setting of Trigger As Played and ArpeggioType is As Played, pressing one key will sound only Tone 0 (kick).

Pressing two keys will sound Tone 0 (kick) and Tone 1 (snare). Pressing three keys will sound all three Tones 0-2 (kick, snare, hi-hat). If the "Velocity" of each Tone is set to Key, each Tone will be sounded at the velocity with which each key was played.

With a setting of Trigger All Tones, playing one key is sufficient to sound all three; Tone 0 (kick), Tone 1 (snare), and Tone 2 (hi-hat). If the "Velocity" of each Tone is set to Key, the Tones will be sounded at the corresponding velocity each time a key is pressed.

Tone 00-11 [C-1...G9]

Specifies the note number for the selected Tone 00-11.

Edit

Here, you can input Tones 0-11 for each step 01 to 48. Step can be a maximum of 48 steps, and Tone corresponds to up to twelve notes for the (up to) twelve keys pressed simultaneously. If "Sort" (p.10) is checked, the notes that were pressed will correspond in ascending order of pitch to Tones 0, 1, etc. If "Sort" is unchecked, the notes that were pressed will correspond to Tones 0, 1, etc. in the order in which they were pressed.

 These parameters are not valid for preset patterns P0-P4.

Tone Grid

The arpeggio pattern is displayed on the grid.

When "Arpeggio Tone Mode" is Normal, the display will indicate "■." When set to Fixed Note, the display will indicate "□."

Step No. (Step Number) [01...48]

Selects the step that you wish to edit, and set/reset each Tone. When the Step No. is selected, use the numeric keys to input the Tones. Numeric keys 0–9 correspond to Tones 0–9, “_” corresponds to Tone 10, and “.” to Tone 11. Each time you press a key, the Tone will be set or reset.

When “Arpeggio Tone Mode” is Normal, the display will indicate “■.” When set to Fixed Note, the display will indicate “□.”

If you wish to delete all Tones of a step, use the Delete Step utility command. To insert a blank step, use the Insert Step utility command.

Pitch Offset [-48...+48]

For each step, the pitch corresponding to the Tone can be raised or lowered in semitone steps. This lets you make settings for the same tone in each step to create a melody, or to make settings for two or more tones in each step to play parallel chords.

Gate [Off, 001...100%, Legato]

Off: That step will not sound even if Tones have been specified.

Legato: Notes will continue sounding until the same Tone is sounded next, or until the pattern returns to the beginning. At this time, the display will change to “●” or “■.”

This setting is valid when the Program, Combination, or Song parameter “Gate” (p.164) is set to Step. When adjusting this setting, make sure that “Gate” is set to Step in the previous mode before entering this page.

Velocity [001...127, Key]

Key: The Tone of the step will sound with the velocity at which the key was played.

001–127: The specified velocity value will always be used.

This setting is valid when the Program, Combination, or Song parameter “Velocity” (p.164) is set to Step.

When adjusting this setting, make sure that “Velocity” is set to Step in the previous mode before entering this page.

Flam [-99...+99]

Specifies how the note timing will be skewed when two or more Tones are specified in the same step.

00: All Tones will sound simultaneously.

+01–+99: The timing of the notes will be skewed in the order of the Tone number. (When Sort is ON, from low note to high note. When Sort is OFF, in the order in which keys were pressed.)

-01–-99: The timing of the notes will be skewed in the opposite direction as “+.”

To simulate chords strummed on a guitar, try setting “+” values for odd-numbered steps and “-” values for even-numbered steps.

This is not valid for preset patterns P0–P4.

Creating a user arpeggio pattern

About user arpeggio patterns

The patterns that can be selected on the microSTATION’s arpeggiator are called “arpeggio patterns.” There are two types of arpeggio patterns: preset arpeggio patterns and user arpeggio patterns.

Preset arpeggio patterns:

There are five patterns; UP, DOWN, ALT1, ALT2, and RANDOM.

The operation of these patterns is fixed, and cannot be edited.

User arpeggio patterns:

There are 640 patterns - U000(INT)–U639(USER) - which can develop chords or phrases in a wide variety of ways, based on the pitches that you play on the keyboard or the timing with which you play them.

In microSTATION Editor/Plug-In Editor, Setup you can modify these user arpeggio patterns, or create a new user arpeggio pattern from an initialized condition. Edited user arpeggio patterns can be written to internal memory areas U000(INT)–U639(USER) (p.203).

Editing a user arpeggio pattern

⚠ If you want to edit a user arpeggio pattern, you must first make sure that memory protect is Off. (p.183)

If you enter this mode from the Program mode, your editing will apply to the arpeggio pattern specified for the selected program.

1. In Program mode, select a program which uses the arpeggio pattern you wish to edit, or a program that you wish to use as a basis for editing the arpeggio pattern.
2. Press the ARP ON/OFF button to turn the arpeggiator on (LED will light-up).
Even if you entered Global mode from a program in which the arpeggiator was turned off, you can use the ARP ON/OFF button to turn it on.
3. Select the Global: Arpeggio Pattern page.

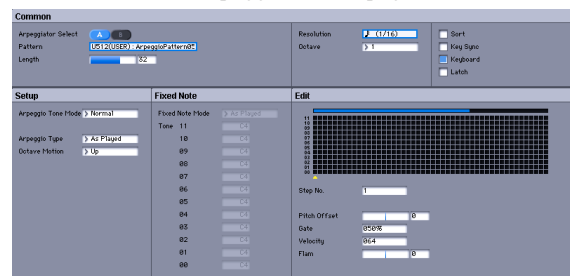

4. “Arpeggiator Select” will automatically be set to A when you navigate to this page from Program mode.
In “Pattern,” select the arpeggio pattern that you wish to edit.
For this example, select an empty user arpeggio pattern.

⚠ If a blank pattern is selected, playing the keyboard will not start an arpeggio. Although preset arpeggio patterns P0–P4 can be selected, they cannot be edited.

⚠ When you edit a user arpeggio pattern, the changes will have an effect anytime that this pattern is used in Program, Combination, or Song.

- In "Length," specify the length of the pattern. After the pattern has played for the length specified, it will return to the beginning. This setting can also be changed during or after editing. For this example, set it to 08.

Note: For the preload arpeggio patterns U000–U639, simply changing the "Length" can significantly change the character of the pattern. Try changing the length and listening to the result.

- Adjust the settings for the "♩ (Tempo)," "Resolution," "Octave," "Sort," "Latch," "Key Sync.," and "Keyboard" parameters. These are program parameters, but they can be set from here as well.

⚠ If after accessing this page from Program mode, you modify these parameters and wish to keep your changes, return to Program mode and write the program. These parameters are not saved by "Write Arpeggio Pattern."

In Arpeggio Pattern Setup, specify how the arpeggio will be developed.

These settings can be changed during or after editing (see page 243).

- Select the Edit page.

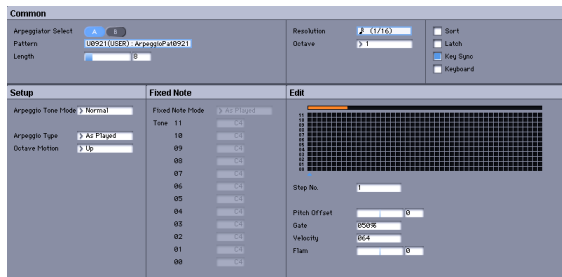

A pattern consists of Steps and Tones.

- Step:** A user arpeggio pattern consists of up to 48 steps. The horizontal axis of the grid represents the steps. The arpeggiator will play starting at the first step, at intervals of the note value specified by the "Resolution." Use "Step No." to select the step, and specify "Pitch Offset," "Gate," "Velocity," and "Flam" for each step.
- Tone:** Each step is able to play a chord of up to twelve Tones ("Tone No. 00–11). The vertical axis of the grid represents the Tone. You can click on the grid to enter a tone. Each time you click a grid, the corresponding tone will turn on or off.

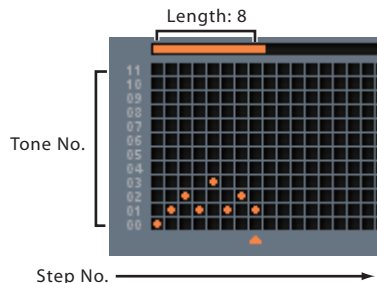

Creating an example pattern

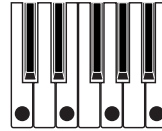

- Click the Step 01, Tone 00.
- Click the Step 02, Tone 01.
- Click the Step 03, Tone 02.
- Click the Step 04, Tone 01.
- Click the Step 05, Tone 03.
- Click the Step 06, Tone 01.
- Click the Step 07, Tone 02.
- Click the Step 07, Tone 02.

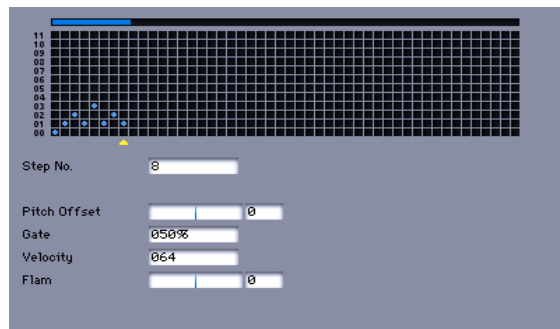

- When you play the keyboard as shown in the illustration, the arpeggiator will begin playing. Tone 0 corresponds to the pitch of the lowest key of chord you play on the keyboard. (If Sort is unchecked, it will correspond to the pitch of the first note you play.)
- For steps 01–08, adjust the settings for "Pitch Offset," "Gate," "Velocity," and "Flam."

"Pitch Offset": This offsets the pitch of the arpeggio note in semitones up or down. You can input the same tone for each step, and change the Pitch Offset value for each to create a melody using a single tone. (See ?Melody pattern?)

"Gate": Specifies the length of the arpeggio note for each step. With a setting of Legato, the note will continue sounding either until the next note of the same tone or until the end of the pattern. With a setting of Off, the note will not sound.

"Velocity": Specifies the strength of the note. With a setting of Key, the note will sound at the strength with which it was actually played.

⚠ The Gate and Velocity settings you make here will be valid if the Gate and Velocity parameters (PROG: Basic-ARP page) of the program selected in Program mode are set to Step. If these parameters have a setting other than Step, the Gate and Velocity that were specified for each individual step will be ignored, and all notes of the arpeggio will sound according to the settings in PROG: Basic-ARP page. Be sure to verify the settings of the program.

⚠ When specifying Gate and Velocity, select the Realtime controls C mode, and set knob 1 (GATE) and knob 2 (VELOCITY) to the center position (12 o'clock).

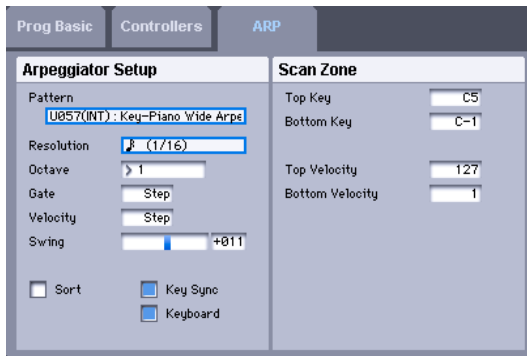

- If you want to edit the user arpeggio pattern name, click the UTILITY button and choose "Rename Arpeggio Pattern" from the menu that appears. If you turn off the power without writing, the edited contents will be lost.
- If you wish to save the state of the program at the same time, return to Program mode and write the program. (p.137)

Other examples of creating a user arpeggio pattern

Melody pattern

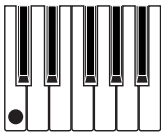

- Click the Step 01, Tone 00. Set "Pitch Offset" to +00.
- Click the Step 02, Tone 00. Set "Pitch Offset" to +10.
- Click the Step 03, Tone 00. Set "Pitch Offset" to +00.
- Click the Step 04, Tone 00. Set "Pitch Offset" to +00.
- Click the Step 05, Tone 00. Set "Pitch Offset" to +12.
- For Step 06, do not enter a tone.
- Click the Step 07, Tone 00. Set "Pitch Offset" to +00.
- Click the Step 08, Tone 00. Set "Pitch Offset" to -02.

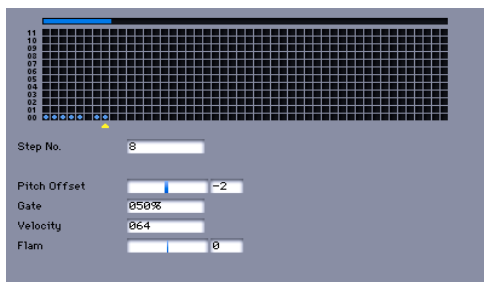

Chordal pattern

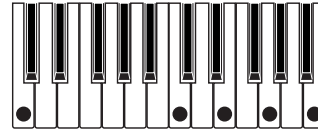

- Click the Step 01, Tone 00. Set "Gate" to Legato.
- For Step 02, do not enter a tone.
- Click the Step 03, Tone 01, 02, 03, 04.
- Click the Step 04, Tone 01, 02, 03, 04.
- For Step 05, do not enter a tone.
- Click the Step 06, Tone 01, 02, 03, 04. Set "Gate" to Legato.
- For Step 07, do not enter a tone.
- Click the Step 08, Tone 01, 02, 03, 04.

Note: To simulate the timing nuances of a strummed guitar chord, select Flam. In Program mode, select an acoustic guitar program, and choose the user arpeggio pattern that you created here. In the Arpeg. PROG: Basic- ARP page, set Gate to Step.

Then return to the Global: Arpeggio Pattern page. For odd-numbered steps, set Flam to a positive (+) value. For even-numbered steps, set Flam to a negative (-) value.

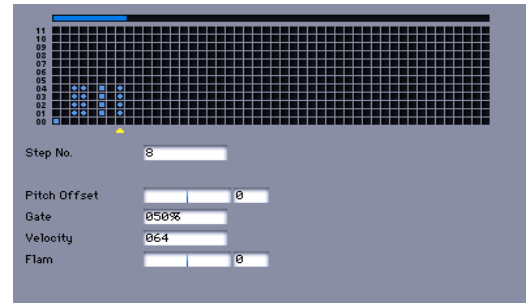

Drum pattern

You can use the arpeggiator to play a rhythm pattern by using "Fixed Note" with a drum program.

- In Program mode, select a drum kit program. For this example, select the preset program Standard kit (Category: DRUM / MALLET / HITS).
- In Global: Arpeggio Pattern page, and parameter settings. "Arpeggio Tone Mode": Set this to Fixed Note. This will cause the tone to always sound at the specified pitch. "Fixed Note Mode": If you set this to Trigger All Tones, playing a single note on the keyboard will sound all tones. If you set this to Trigger As Played, the tones will be sounded according to the notes you play on the keyboard (p.196).

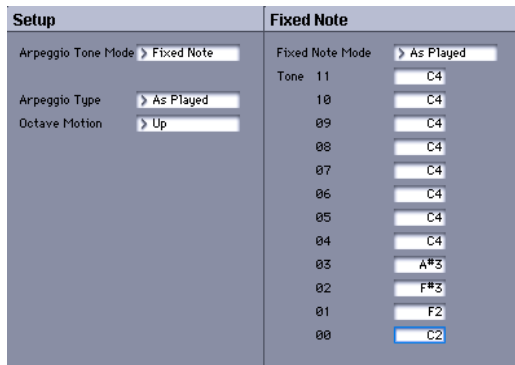

Let's input the following rhythm pattern.

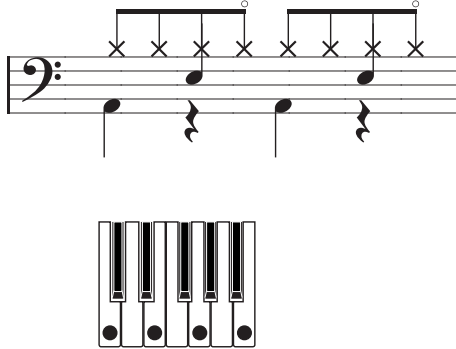

- Adjust the settings for "Tone No." and "Fixed Note No." Select "Tone No.," and set Fixed Note No. to the note number that will be sounded by that tone. For each horizontal line (Tone) in the screen, you will specify the drumsample (note number) of the drum kit. Each Tone will be displayed as a small circle. For this example, set Tone No. and Fixed Note No. as follows.

Tone No.	Fixed Note No.
00	C2 (kick)
01	F2 (snare)
02	F#3 (closed hi-hat)
03	A#3 (open hi-hat)

The drumsamples that correspond to each note number will differ depending on the drum kit. It is convenient to audition the drum sounds from the keyboard, and then input Fixed Note No. Turn on the "Chase on" and by holding down the KEY button and playing the desired key.

- Input the kick (Tone00).
Click the Step 01, Tone 00.
Then click the Step 05, Tone 00.
- Input the snare (Tone01).
Click the Step 03, Tone 01.
Then click the Step 07, Tone 01.
- Input the closed hi-hat (Tone02).
Click the Step 01, Tone 02.
Click the Step 02, Tone 02.
Click the Step 03, Tone 02.
Click the Step 05, Tone 02.
Click the Step 06, Tone 02.
Click the Step 07, Tone 02.
- Input the open hi-hat (Tone03).
Click the Step 04, Tone 03.
Then click the Step 08, Tone 03.
If "Fixed Note Mode" is set to Trigger All Tones, playing a single note on the keyboard will cause the rhythm pattern to play.

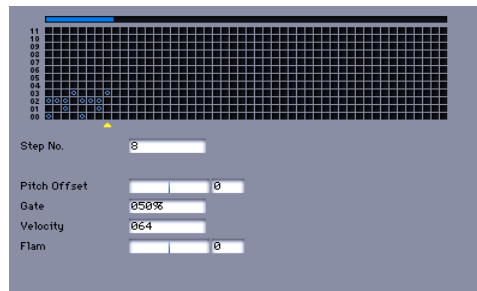

If "Fixed Note Mode" is set to Trigger As Played, playing a single note on the keyboard will cause only the kick (Tone00) to play.

Playing two notes on the keyboard will cause only the kick (Tone00) and snare (Tone01) to play. In this way, the number of keys that you play will be played by the same number of tones.

- Set the parameters for each step.
Use "Velocity" etc. to add accents to the rhythm pattern.
- The "Gate" and "Velocity" settings you make here will be valid if the Gate and Velocity parameters (PROG: Basic- ARP page) of the program selected in Program mode are set to Step. If these parameters have a setting other than Step, the Gate and Velocity that were specified for each individual step will be ignored, and the notes of the arpeggio will be sounded according to the settings of the PROG: Basic- ARP page. Check the settings of the program.
- When specifying Gate and Velocity, select realtime controls C mode, and set knob 1 (GATE) and knob 2 (VELOCITY) to the center position (12 o'clock).

Dual arpeggiator editing

Here we will use a combination as an example in our explanation.

The same procedure applies when editing an arpeggio pattern in Sequencer mode.

If you have entered this mode from the Combination mode, the arpeggio pattern selected by the combination will be affected by your editing.

- In Combination mode, select a combination that uses the arpeggio pattern you wish to edit.
For this example, select a combination where both arpeggiators A and B are assigned.
- Press the ARP ON/OFF button to turn on the arpeggiator (LED will light-up).
Even if the arpeggiator had been turned off when you moved here, you can use the ARP ON/OFF button to turn it on. However, if "Arpeggiator Run" A or B are Off, and if "Arpeggiator Assign," is set to off, then the arpeggiator will not operate.
- Select the Global: Arpeggio Pattern page.
- If you accessed this page from Combination mode, use the "Arpeggio Select" A and B to select the arpeggiator that you wish to edit.
If this is A, your editing will apply to the parameters and user arpeggio pattern of arpeggiator A.
If this is B, your editing will apply to the parameters and user arpeggio pattern of arpeggiator B.
- Switch between arpeggiators A and B, and edit their respective user arpeggio patterns.
If you wish to stop one of the arpeggiators, return to Combination mode, and in CONBI EDIT: ARP- Arp-A or the Arp-B page and turn off the "Arpeggiator Run."
- To modify the name of a user arpeggio pattern, use the

Utility command “Rename Arpeggio Pattern.” (See page 255)

7. If you wish to save the edited user arpeggio pattern in internal memory, you must write the user arpeggio pattern.
In this case, both user arpeggio patterns will be written simultaneously. If you turn off the power without writing, the edited contents will be lost (☞p.203).
8. If you wish to save the state of the combination at the same time, return to Combination mode and write the combination. (☞p.203)
Note: When editing a user arpeggio pattern, pay attention to the global MIDI channel, the channel of each track, and the arpeggiator assignments, and make sure that the arpeggiator you are hearing is the pattern that you wish to edit.

MIDI Clock and Start messages received from a connected MIDI device.

Note: Synchronization will occur in the same way if MIDI Clock is Auto and MIDI realtime clock messages are being received from a connected MIDI device.

Synchronization with external MIDI clock

The arpeggiator will synchronize to the “♩(Tempo)” timing of the external MIDI clock.

Synchronization with MIDI realtime Start messages

If the arpeggiator is turned on and running, an incoming MIDI realtime Start message will reset the arpeggiator to the beginning of its pattern (This is unaffected by the “Key Sync.” setting).

Regarding arpeggiator synchronization

“Key Sync.” parameter

The timing of the arpeggiator notes depends on the state of the arpeggiator “Key Sync.”

If this is On, the arpeggiator will start running at the first note-on that occurs after you’ve taken your hands completely off the keyboard.

If this is Off, the arpeggiator will run in synchronization with the internal/external MIDI clock.

Below, we will explain how synchronization occurs when the “Key Sync.” is Off (Synchronization with Song Start and with MIDI realtime Start messages are excluded).

Synchronization between arpeggiators A and B

In Combination and Sequencer modes, the two arpeggiators can run simultaneously. In this case, if one arpeggiator is already running, and you then run the other arpeggiator (with “Key Sync.” is Off), the second arpeggiator will synchronize to the “♩(Tempo)” based on the first arpeggiator.

If “Key Sync.” is On, arpeggiators A and B will run independently, each at their own tempo.

Synchronization between the arpeggiator and sequencer in Sequencer mode

If song playback is stopped

- The arpeggiator will synchronize to the “♩(Tempo)” based on the internal MIDI clock timing.

While playing back or recording a song

- The arpeggiator will synchronize to the beat based on the timing of the song.

Synchronization with Song Start

- If the arpeggiator is turned on (ARP ON/OFF button is on) and is running, it will reset to the beginning of its arpeggio pattern when a Song Start is received. (This is unaffected by the “Key Sync.” setting.)
- In Sequencer mode when “Key Sync.” is Off and the ARP ON/OFF button is on, if you start the arpeggiator by pressing a key during the pre-count before recording begins, the arpeggiator will start its pattern as soon as recording begins, and will be recorded.

Synchronization with external sequencer playback

If “♩(Tempo)” is EXT (i.e., if Global: MIDI-MIDI Clock, “Clock” is Ext.MIDI or Ext.USB) in Program, Combination, or Sequencer modes, the arpeggiator will synchronize to the

UTILITY Command

Procedure for utility commands

1. Click the UTILITY button, and choose a command from the menu that appears.
2. Adjust settings in the dialog box.
For details on the contents of each dialog box, refer to the explanation for each command.
3. Click the OK button to begin, or click the Cancel button if you decide not to continue.

Save as Default

Writes (saves) the global mode Software Setup settings of the editor as the default settings that will be used when you start up the editor.

Note: Save as Default is available on all of the Software Setup page.

Write Global Setting

This command writes Global mode settings (except for Drum Kits and Arpeggio Patterns).

Note: To save the drum kit, use the utility command. ("Write Drum Kits")

Note: To save the arpeggio pattern, use the utility command. ("Write Arpeggio Patterns")

Select Auto Load File

In the Software Setup page, use "Load data file automatically" to select the desired file.

Note: Refer to "Load data file automatically."

Select Auto Load File is available on all of the Software Setup page.

Rename External Setup

This lets you rename the external setup.

Rename External Setup is available on the External tab of the MIDI page.

Reset Controller MIDI Assign

This automatically assigns the MIDI control change messages for each controller of the Global: Controllers– ARP Controllers.

See "Reset ARP CC#" on page 66.

Reset Controller MIDI Assign is available on the Basic/Controller page.

Copy Scale

This command copies data from a preset scale to a user scale or copies a user scale to another user scale location.

For details on the preset scales, please see Type (p.82).

Copy Scale is available on the User Scale page.

1. Use the From field to select the copy-source scale.
If you select Pure Major or Pure Minor, specify the Key (located at the right) as well.
Stretch cannot be selected if "To" is User All Notes Scale.
2. In "To," selects the copy destination scale.

Write Drum Kits

This saves all drum kits 00 (INT)–47 (USER).

You must write an edited drum kit if you want to keep it. Edited drum kits cannot be recovered if you turn off the power before saving them.

Rename Drum Kit

This renames a drum kit.

Rename Drum Kit is available on all of the tabs under the Drum Kit page.

Copy Drum Kit

This command copies the settings of another drum kit to the currently-edited drum kit.

Copy Drum Kit is available on all of the tabs under the Drum Kit page.

Drum kits 48 (GM)–56 (GM) cannot be edited, but you may copy them to another drum kit and then edit them.

Select the copy source drum kit (From).

 When you use the "Copy Drum Kit" function, the settings of the drum kit that's currently selected will be overwritten.

Copy Key Setup

This command copies the settings of an individual key to another key. You can also copy settings from two or more contiguous keys at once.

Copy Key Setup is available on all of the tabs under the Drum Kit page.

1. In the "From Key" fields, select the range of keys that you wish to copy.
2. In the "To Key" field, select the copy destination key. If you selected two or more keys in the "From Key" field, their settings will be copied to the keys starting at the To Key and continuing upward.

Swap Key Setup

This command exchanges (swaps) the settings of one key with the settings of another key.

Swap Key Setup is available on all of the tabs under the Drum Kit page.

Use "Source Key 1" and "Source Key 2" to specify the keys whose settings you want to swap.

Write Arpeggio Patterns

This command writes user arpeggio patterns U000–U639. Write Arpeggio Patterns is available on the Arpeggio Pattern page.

 “Pattern,” “↓(Tempo),” “Octave,” “Resolution,” “Sort,” “Latch,” “Key Sync,” and “Keyboard” are parameters that are set in Program, Combination, and Song. The Write operation used here does not save these parameters.

If you move here from Program or Combination mode and set these parameters, you must return to the original mode and write them.

Rename Arpeggio Pattern

This command renames the selected user arpeggio pattern. Preset patterns P0–P4 cannot be renamed. Rename Arpeggio Patterns is available on the Arpeggio Pattern page.

Copy Arpeggio Pattern

This command copies the settings of another user arpeggio pattern to the currently selected arpeggio pattern. It is not possible to copy from a preset arpeggio pattern P0–P4.

Select the copy source arpeggio pattern “From.”

Copy Arpeggio Patterns is available on the Arpeggio Pattern page.

 Be aware that when you use the “Copy Arpeggio Pattern” function, all settings of the arpeggio pattern that’s currently selected will be overwritten.

Initialize Steps

This command initializes the step parameters (“Tone,” “Pitch Offset,” “Gate,” “Velocity,” “Flam”) of the arpeggio pattern.

Empty will initialize all tones to a blank state.

Full will initialize all tones to a full state.

Initialize Steps is available on the Arpeggio Pattern page.

Copy Step

This command copies the settings of a specific step. The settings of two or more adjacent steps can also be copied together.

Copy Step is available on the Arpeggio Pattern page.

1. In “From Step,” select the range of steps that you wish to copy.
2. In “To Step,” select the copy destination step.
If you selected more than one step in “From Step,” the steps will be copied starting at “To Step” and continuing through the steps to the right.

Delete Step

This command deletes the step parameters (“Tone,” “Pitch Offset,” “Gate,” “Velocity,” “Flam”) of the step number that’s currently selected. Subsequent steps will move one column toward the left.

Delete Step is available on the Arpeggio Pattern page.

Insert Step

This command inserts an empty step into the step number that’s currently selected. Subsequent steps will be moved one step to the right.

Insert Step is available on the Arpeggio Pattern page.

Rotate Step

This command rotates the step settings.

Select the Direction of rotation.

Rotate Step is available on the Arpeggio Pattern page.

For example, suppose there is a pattern of Length 4.

If you select Forward, the settings of Step 1 will be rewritten to 2, Step 2 → 3, Step 3 → 4, Step 4 → 1.

If you select Backward, the settings of Step 1 will be rewritten to 4, Step 2 → 1, Step 3 → 2, Step 4 → 3.

Load

Loads the microSTATION Editor/Plug-In Editor data that was previously saved on the computer.

Save

Saves data from the microSTATION Editor/Plug-In Editor to your computer as dedicated file.

Note: These functions load or save the data as dedicated files for the editor application.

Receive All

Receives all data from the microSTATION data into the editor.

Note: The sequencer performance data of Sequencer mode is excepted.

Transmit All

Transmits all data in the microSTATION Editor/Plug-In Editor to the microSTATION and writes it into internal memory.

Receive Global Data

Receives the global data from the microSTATION into the microSTATION Editor/Plug-In Editor.

Receive Arpeggio Pattern

Receives the arpeggio pattern data from the microSTATION into the microSTATION Editor/Plug-In Editor.

Transmit Global Data

Transmits the global data from the microSTATION Editor/Plug-In Editor to the microSTATION and writes it.

Transmit Arpeggio Pattern

Transmits the arpeggio pattern data from the microSTATION Editor/Plug-In Editor to the microSTATION and writes it.

Receive Current Arpeggio Pattern

Receives the arpeggio pattern data that's currently selected from the microSTATION into the microSTATION Editor/Plug-In Editor.

Transmit Current Arpeggio Pattern

Transmits the arpeggio pattern data that's currently selected from the microSTATION Editor/Plug-In Editor to the microSTATION and writes it.

Import

Loads PCG data from the microSTATION into the microSTATION Editor/Plug-In Editor.

Export

Data created in the microSTATION Editor/Plug-In Editor can be saved as PCG data for the microSTATION.

All Sound Off

Depending on the host application, "hung" notes may occur while using the host's functions. If this happens, please use this command.

Effect Guide

Overview

The microSTATION provides five insert effects, two master effects, and a total effect, together with a mixer section that controls the routing of these effects.

For each of these effect processors, you can choose from 134 different types of effects, grouped into the following categories:

Classification of 134 effects

Effect type	Contents
Dynamics: 000–006	Effects which control volume, such as compressors, limiter, and gates
EQ/Filter: 007–019	Effects which control frequency content, such as EQ, multi-mode filter, exciter, and wah
Overdrive/Amp/Mic: 020–028	Overdrive and amp modeling effects such as guitar/bass amps and mics
Phaser/Modulation: 029–042	Pitch and phase modulation effects such as chorus and flanger
Mono - Mono Serial (Dyn/EQ/Phs): 043–061	Other modulation effects such as tremolo and rotary speaker, and pitch shifters
Organ FX: 062–063	Delays
Chorus/Flanger/Pitch Mod: 064–081	Reverb and early reflections
Mono - Mono Serial (Cho/Flng): 082–087	Mono & Mono chain effects that internally connect two mono effects in series
Delay: 088–104	Mono & Mono parallel effects that allow two mono effects to be applied to L and R independently
Reverb/ER: 105–113	Double size effects
Mono - Mono Serial (Delay): 114–120	Effects which control volume, such as compressors, limiter, and gates
Double Size: D00–D13 (121–134)	Effects which control frequency content, such as EQ, multi-mode filter, exciter, and wah

Effects in each mode

Program mode

With Programs, you can use insert effects to process the final sound in the same way that you use the Filter, Driver, Amplifier, and EQ (equalizer) to process the sound from the oscillators (OSC 1 & 2). Then the master effects are used to create overall ambience such as reverb, and use the total effect to make final adjustments. All of these settings can be made independently for each program.

Combination, Sequencer mode

In Combination and Sequencer modes, you can use the track EQ and insert effects to process the program sound of each timbre/track. You can then use the master effects to create overall ambience, and use the total effect to make final adjustments.

In Combination mode you can make these settings for each combination, and in Sequencer mode you can make them for each song.

In Sequencer mode, you can switch between effects or modify the effect parameters and record these changes, so that effects will switch automatically or effect parameters will be modified automatically as the song plays back.

Editing effect parameters on the microSTATION itself

On the microSTATION itself, you can only edit the main parameters of each effect.

On the tables that explain the effect parameters on page 217 and following, the parameter names are listed in either “Full parameter” or “Quick parameter.” If a parameter’s name is listed in the “Quick parameter” column or if this column indicates “← (same name as full parameter),” that parameter can be edited on the microSTATION itself.

microSTATION Editor allows you to edit all of the effect parameters. You’ll use microSTATION Editor/Plug-In Editor to perform detailed editing of parameters such as dynamic modulation.

Program mode

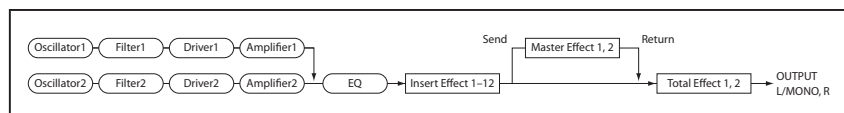

Combination, Sequencer mode

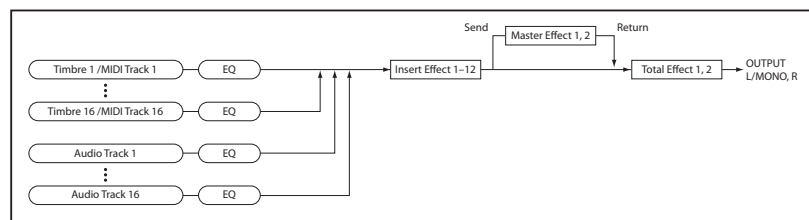

Dynamic modulation (Dmod) and Tempo Synchronization

Dynamic modulation (Dmod)

Dynamic modulation lets you control certain effects parameters in real-time, using either the built-in controllers or MIDI. These effect parameters are marked with the logo .

For more information, please see “Dynamic Modulation Sources (Dmod)” on page 380.

Tempo Synchronization

You can synchronize some effects parameters, such as LFO speeds and delay times, to the system tempo. This lets you sync the effects to Program LFOs, Arpeggiator, the internal sequencer, or an external MIDI clock.

These effects parameters are marked with the logo .

Synchronizing LFOs

Most effects with LFOs, such as S11: St.Wah, can be synchronized to tempo. This applies to the individual effects LFOs.

To set up LFOs to synchronize to tempo:

1. Set “MIDI Sync” to On.
2. Set the BPM as desired.
To synchronize to the system clock, set BPM to MIDI.
To set the LFO to a specific tempo, separate from the system clock, set BPM to the desired tempo (between 40.00 and 300.00 BPM).
3. Use the “Base Note” and “Times” (x) parameters to set the rhythmic value of the LFO.
For instance, if you set “Base Note” to 1/8 and “Times” (x) to 2, each cycle of the LFO will last for a quarter-note (two eighth-notes).

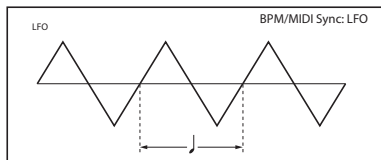

Synchronizing Delay Times

Delays with “BPM” in their title will sync to tempo.

For instance, you might set up effect 102: Stereo BPM Delay for master effect 2 as follows:

1. Set L Delay Base Note to 1/32, and Times (x) to 4
2. Set R Delay Base Note to 1/32, and Times (x) to 6
In this case, the left channel delay time will correspond to four 32nd notes, and the right channel delay time will correspond to six 32nd notes.

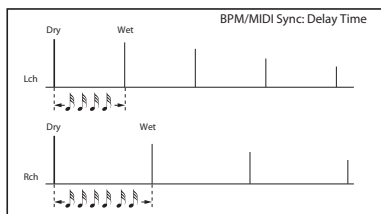

If the tempo, “Base Note,” and “Times” settings combine to exceed the maximum delay time, an indication such as “Time Over?: OVER” is displayed (only on the microSTATION itself). Please adjust the settings so that this indication does not appear. (The maximum delay time will depend on the effect.)

Dynamic modulation to control an effect parameter in realtime

Use the microSTATION Editor / Plug-In Editor to make these settings.

1. Enter Program mode, and select a desired program.
2. Access the MFX/TFX page MFX2.
3. In MFX&TFX Routing, set “MFX2” to 099: L/C/R BPM Delay.
Verify that the delay sound is being output.

Now, we can set the Dmod to change the delay level via the Joystick

4. Set “Input Lvl Dmod” to +100.
5. Set “Source” to JS+Y: #01. The delay sound will disappear.
The input level to the effect can be controlled by the joystick. As you move the joystick away from you, the delay sound will gradually increase.

Using a foot switch connected to the DAMPER/PEDAL/SW jack to vary the feedback level via Dmod

6. Connect a foot switch to the rear panel DAMPER/PEDAL/SW jack.
7. Enter GLOBAL mode, and in Basic/Controllers - Controller, set the Foot Switch/Pedal/Damper “Type Sw/Pedal” to Switch, and set “Foot Switch Function” to Foot Switch.

8. Access the Program mode MFX/TFX page MFX2, and set the L/R/C BPM Delay parameter C Delay “Source” to FootSW: #82 and “Amount” to +30.

When you move the joystick away from yourself and press the foot switch, the feedback level will increase, and the delay sound will continue for a longer time. The “Amount” setting specifies the feedback level that will be in effect when the foot switch is pressed. If “Amount” is set to -10, pressing the foot switch will reduce the feedback level to 0.

Finally, we can use the MIDI/Tempo Sync function to synchronize the delay time to the arpeggiator tempo.

9. Set “BPM” to MIDI.
10. For L, C, and R, set the Delay Base Note and Times as desired.
For this example, set Delay Base Note to  and Times to x4 so that the effect will be easily understandable. The delay time will repeat at an interval of a 8th note.
11. Switch to Realtime Control C mode, and turn knob 4 (TEMPO); the delay time will change.
When you (push the joystick away from yourself and) press the foot switch, the feedback level will rise, and the delays will become longer.
12. When you turn on the ARP ON/OFF button, arpeggiator will begin playing.
Select any desired arpeggiator. When you switch to Realtime Control C mode and turn knob 4 (TEMPO), the delay time will change in synchronization with the changing tempo of the arpeggiator playback.

 Depending on the specific delay effect, you may hear some unexpected noise if you change the knob4 (TEMPO) while the delay is sounding. This is because the delay sound becomes discontinuous, and is not a malfunction.

 For some effects, you can synchronize the LFO frequency to the tempo. Set the effect parameters “MIDI Sync” to On, and BPM to MIDI. (“Tempo Synchronization”)

FX Control Bus

The FX Control Buses lets you create effects “sidechains.” Sidechains let you control an effect with one audio signal (the sidechain), while the effect processes a completely different audio signal.

This is convenient for use with vocoders and limiters, gates, etc. You can use a voice-type timbre to modulate a synth-type input to create rhythmic vocoder effects. Limiter or gate-type effects are often used to control an input using a different sound.

microSTATION includes two true- stereo FX Control Buses, which can be used with the following effects:

Vocoder

D09: Vocoder

Limiter, and gate effects

S03: Stereo Limiter

S06: Stereo Gate

Example: Limiter (Combination)

Compressor-type effects use the level of the audio input to control the level gain of the audio output.

For these effects, the envelope detection source can be either the audio input itself (the usual method) or FX Control Bus 1 or 2.

The example shown in the diagram is of a split combination in which the level of timbre 1 (Pad, played from the low key range) is being controlled by timbre 2 (Guitar, with IFX2 OD/Wah inserted, played from the high key range). You can adjust the settings so that when you play the guitar sound, the volume of the pad will decrease automatically. Send the post-IFX2 signal via FX Control Bus to FX Ctrl1, and set the IFX1: St.Limiter Envelope Source parameter to FX Control 1.

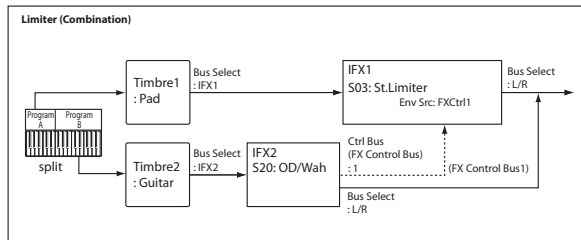

Example: Vocoder (Combination)

Vocoder effects produce their distinctive sound by using an audio signal (the modulator) to modulate a different audio signal (the carrier).

As shown in the illustration, using the output of timbre 1 as the carrier and the voice-type output of timbre 2 as the modulator allows you to create distinctive “talking” effects.

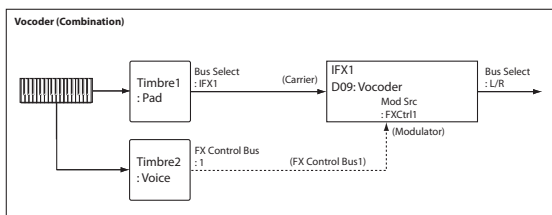

Example: Rhythmic Vocoder (Combination)

The vocoder is a unique effect that uses one audio signal (the modulator) to modulate another audio signal (the carrier). By using an arpeggiated drum pattern as the modulator, you can produce a rhythmic vocoder effect. As shown in the illustration, this example sends the drum pattern played

by the timbre 2 arpeggiator to the FX Control bus and uses it as the vocoder’s modulator.

For timbre 1 (the carrier), set “Bus” to IFX1, sending it to IFX1: vocoder. For timbre 2 (the modulator), set “FX Control Bus” to 1, sending it to FX control bus 1. Set IFX1: Vocoder’s “Mod Src” to FXCtrl1 so that the arpeggiated drum pattern signal of timbre 2 will be the modulator for the vocoder.

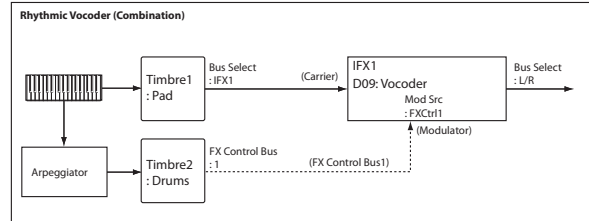

Effect I/O

To achieve the best tonal quality, signals sent to the effects should be at the maximum level below clipping. Also, use the Wet/Dry parameter for the Insert Effects, Total Effect and the “Wet/Dry” or “Return 1, 2” parameter for the Master Effects to adjust the effect output level.

⚠ If the input level is too low, the SN ratio may decrease. On the other hand, if the input level is too high, clipping may occur.

The following table shows the parameters related to the level settings:

Program mode

Input	OSC 1/2 Volume
	Send1/2
	Effect Trim parameter *1
Output	Effect Wet/Dry parameter
	Return 1, 2
	Master Volume

Combination mode/Sequencer mode

Input	Volume
	Send1/2
	Effect Trim parameter *1
Output	Effect Wet/Dry parameter
	Return 1, 2
	Master Volume

*1 Some effects may not have these parameters.

Insert Effects (IFX1–IFX5)

In/Out

Insert Effects (IFX 1–5) have a stereo input and a stereo output. If you set the Wet/Dry parameter to Dry (no effect), the input signal will be passed through, in stereo, without being processed by the effect. If you select Wet (effect applied), the processed signal will be output in one of the following ways:

Wet	Mono In - Mono Out	
	Mono In - Stereo Out	
	Stereo In - Stereo Out	

Input/output variations for each effect are shown in upper left of the block diagrams starting on page 217.

If you select 000: No Effect, stereo input signals are output in stereo without being processed.

In each mode, you can use IFX1–IFX5 “On/Off” to turn the effect on/off. If an effect is off, it will be bypassed. Just as when 000: No Effect is selected, the stereo input sound will be sent through as a stereo output.

MIDI The microSTATION can also turn IFX1–IFX5 off separately from the setting of the On/Off button by receiving MIDI control change message CC#92. Value 0 will turn them off, and value 1–127 will turn them on. You can also use “Effect SW” (p.59) to turn IFX1–5 on and off. This MIDI control is performed on the global MIDI channel (p.60).

Double-size effects

Double-size effects (D00: St.MltLmt– D13: Early Ref) use twice as much space as other effects.

You can use double-size effects for insert effects IFX1–IFX4 and master effect MFX1. However, the effect of the number that follows it will be unavailable. For example if you’ve selected a double-size effect for IFX1, you won’t be able to use IFX2. If you’ve selected a double-size effect for MFX1, you won’t be able to use MFX2.

Routing

You can use up to five channels (IFX 1–5) for the Insert Effects in any mode.

Program mode

Use “Bus” to set the destination bus of the oscillator output.

L/R: Send the output to the L/R bus. Instead, it is sent to OUTPUT L/MONO and R after the TFX.

IFX1...5: The signal is sent to Insert Effects IFX 1–5.

Off: The output will not be sent to the L/R bus, or IFX1–5 buses. Choose the Off setting if you want to connect the oscillator output to a master effect in series. Use OSC1 Send1, OSC1 Send2, OSC2 Send 1, and OSC2 Send2 to adjust the send level.

Use OSC1 Send1, OSC1 Send2, OSC2 Send 1, and OSC2 Send2 to specify the send level for the Master Effects. This setting is effective if “Bus” is set to L/R or Off.

If “Bus” is set to IFX1–5, use “Send1” and “Send2” (p.12) to specify the send level of the post-IFX signal.

MIDI Send1 responds to CC#93, and Send2 responds to CC#91. At this time, the actual send level uses the value of the Send 1 and 2 settings for Oscillators 1 and 2, multiplied by the Send 1 and 2 values received via MIDI.

In the example shown in the next diagram, Oscillators 1 and 2 outputs being sent to IFX1.

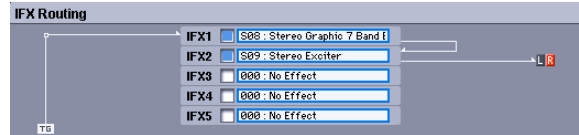

If you want to connect insert effects in series, turn “Chain” On and use “Chain To” to specify the chain-destination.

Effects can be chained only in ascending order of their number; for example IFX1 can be chained to IFX2 through IFX5, and IFX2 can be chained to IFX3 through IFX5. You can create a chain of up to five insert effects in series, IFX1 through IFX5.

When the Insert Effects are connected in series, the values of the “Pan(CC#8),” “Bus,” “Send1,” and “Send2” parameters for the post-IFX signal will be used.

In the following illustration, “Chain” is On and “Chain To” is set to the next IFX, creating a series connection of IFX1→IFX2→IFX3. The “Pan (CC#8),” “Bus,” and “Send 1” and “Send 2” settings after the signal has passed through IFX3 will be used.

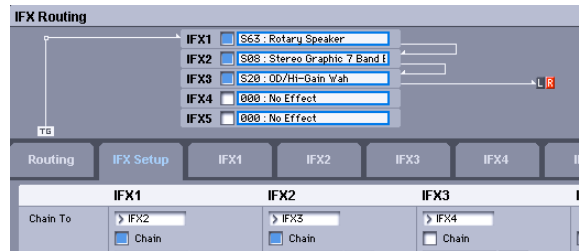

For a drums program

If the program’s “Oscillator Mode” (which you can edit in the editor) is Drums, the “Use DKit Setting” will be valid. See the following illustration.

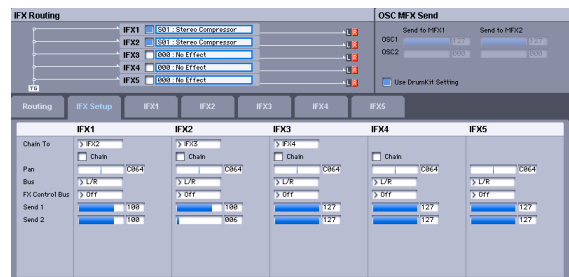

If this is On, the “Bus (IFX/Output),” “FX Control Bus,” “Send 1,” and “Send 2” (which you can edit in the microSTATION Editor/Plug-In Editor) of each key of the assigned drum kit will be valid.

For example, you can send a snare sound to IFX1 to apply the Gate effect, a kick sound to IFX2 to apply EQ, and other sounds to OUTPUT L/MONO and R without applying any Insert Effects.

Tip: In most of the preloaded drum kits, the following types of drum instrument have the same Bus (IFX/Output) Select settings.

- Snares → IFX1
- Kicks → IFX2
- Other → IFX3

If you de-select the box, all drum instrument outputs are sent to the bus specified by “Bus” (p.12). You may apply any Insert Effects to all drum instruments, regardless of the DrumKit settings.

If this is Off, the output of all drum instruments will follow the “Bus” setting. This lets you apply an insert effect to all drum instruments, regardless of the settings of the drum kit.

Combination and Sequencer modes

Use “Bus” for timbres (Combination) and tracks (Sequencer) to select an Insert Effect to apply to the corresponding timbres and tracks. You can route multiple timbres and tracks to a single Insert Effect.

Tip: You can use each timbre/track’s “Bus,” post-IFX Chain to and “Chain” parameters to create a variety of routings.

Example: Inserting one IFX into two or more timbres

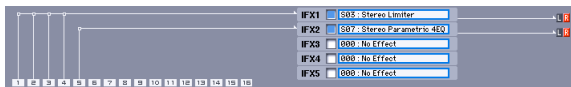

Example: Inserting a separate IFX into each timbre, and inserting another IFX later

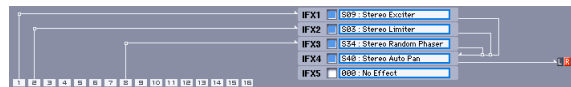

Example: Sharing part of a timbre’s IFX chain with another timbre

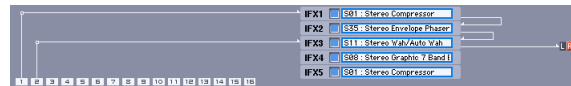

As with Program mode, select L/R, IFX1–5, or Off for each timbre and track.

“Send1” and “Send2” become available if “Bus (Bus Select)” has been set to L/R or Off. If you’ve set “Bus (Bus Select)” to IFX1–5, use “Send1” and “Send2” (p.19, p.37) following the insert effect to adjust the send levels.

MIDI Send1 responds to CC#93, and Send2 responds to CC#91. At this time, the actual send level uses the value of the Send 1 and 2 settings for Oscillators 1 and 2 of the Programs (selected for the timbres and tracks), multiplied by the Send 1 and 2 values received via MIDI.

The following diagram shows an example of Combination mode. The Timbre 1 output is sent to IFX1 and the Timbre 2 output is sent to IFX2 according to the “Bus” setting. Other

An example of when a double-size effect is selected for IFX1 and IFX4



timbres are sent to L/R. The output signal passes through the TFX, then goes to OUTPUT L/MONO and R.

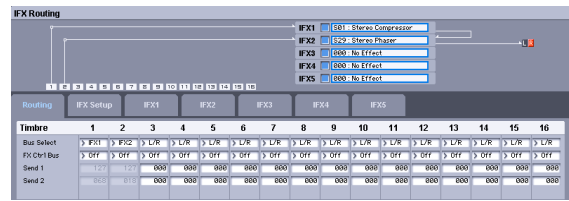

In the following illustration, the IFX1 “Chain” is On and “Chain to” is set to IFX2, so that the output of IFX1 is sent to IFX2.

Timbre 1 is being processed by IFX1: S01: St.Comp and IFX2: S29: St. Phaser effects. Timbre 2 is being processed by the IFX2: S29: St. Phaser effect. The Routing Map area of the next diagram shows these settings. (With these settings, IFX3–5 are not being used.)

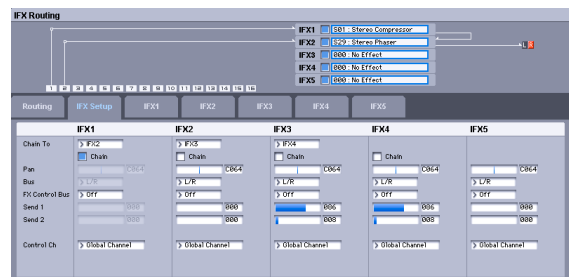

Drum Programs in Combination and Sequencer modes

If you’ve selected a drum program (Oscillator Mode=Drums) for a timbre (in Combination mode) or track (in Sequencer mode), the DKit setting will be available as a choice for “Bus” (see the following diagram).

With the DKit setting, settings such as the “Bus (IFX/Output)” setting of each key of the drum kit (which you can edit in the microSTATION Editor/Plug-In Editor) will be valid, and each drum instrument will be output to the bus destination. For example, snare sounds could be sent to IFX1, kick sounds to IFX2, and other sounds to L/MONO and R.

With settings other than DKit, the output of all drum instruments will follow the “Bus” setting of each timbre/track. This lets you apply an insert effect to all drum instruments, regardless of the settings of the drum kit.

Drum Kit IFX Patch

If “Bus” is set to DKit, you’ll be able to set the “DKit Patch.” This option allows you to change the routing of the Insert Effects temporarily by changing “Bus (IFX/Output) Select” for each key.

For example, assume that the DrumKit key assignment is set so that a snare sound is routed to IFX1 and a kick sound is routed to IFX2 etc., IFX1–3. In this case, if you wish to assign IFX 1 and 2 to the Programs used by other timbres and tracks, you can view the routing so that these DrumKit sounds are routed to IFX3 and IFX5 respectively.

Patching is possible only if the “Bus (IFX/Output)” setting of each key of the drum kit (which you can edit in the microSTATION Editor/Plug-In Editor) is assigned to an insert effect. The state of these settings can also be viewed in the Routing map of the editor. Choose “DKit Patch,” and then press the OK button to confirm.

If you want to revert to the original settings of the drum kit, use the Drum Kit IFX Patch with the settings IFX1 → IFX1, IFX2 → IFX2, IFX3 → IFX3, IFX4 → IFX4, and IFX5 → IFX5.

In the following diagram, Drum Program is assigned to Timbre 1, and normal Programs are assigned to Timbres 2 and 3. “Bus” is set to DKit for Timbre 1, IFX1 for Timbre 2, and IFX2 for Timbre 3. With Timbre 1, the Bus (IFX/Output) Select for DrumKit setting becomes effective.

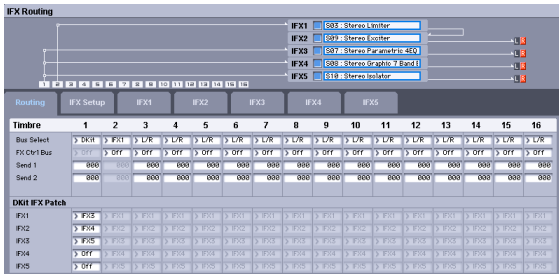
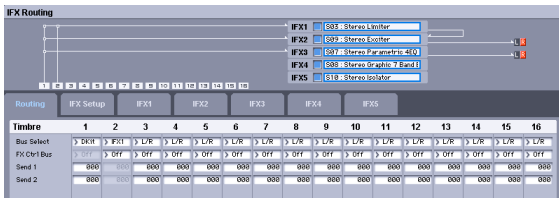

Use the “DKit Patch” parameter if you want the drum program to use effects other than timbres 2 and 3. Temporarily send the drum kit IFX1 to IFX3, IFX2 to IFX4, and IFX3 to IFX5. Executing with these settings will temporarily change the effects where the drum kit is being sent.

Mixer

In Program, Combination, and Sequencer modes, the insert effect pages (IFX1–IFX5) allow you to specify the “Pan (CC#8),” bus select “Bus,” FX Control bus “FX Ctrl,” and master effect send levels “Send 1” and “Send 2” for the signal that has passed through the insert effect.

If you have turned on the “Chain” to connect the Insert Effects in series, these parameters Pan(CC#8)– Send2 for the post-IFX (last Insert Effect in the chain) signal become effective.



Pan: CC#8

This parameter enables you to set the pan of the post-IFX signal.

If you are using the stereo-in/stereo-out Insert Effects, set this parameter to “C064” to enable the Pan settings for the oscillators, timbres, tracks.

If you are using mono-in/stereo-out or mono-in/mono-out Insert Effects, the Pan settings for the oscillators, timbres, and tracks are ignored, and they are set to Center. Use the Pan(CC#8) parameter to set the pan. “L000” is hard left, and “R127” is hard right.

For more about effect types such as stereo-in/stereo-out, See “In/Out” on page 208.

MIDI You can control these parameters via CC#8.

Bus (Bus Select)

This parameter enables you to specify the destination bus for the post-IFX signals.

L/R is a common setting to send signals to the Total Effect (TFX) before they are routed to the OUTPUT L/MONO and R outputs.

If set to Off, the signal will not be sent to the L/R bus. Choose this setting if you want to use the “Send1” or “Send2” levels to route the signal through a master effect in series (i.e., not as a send effect).

Insert Effect = Stereo In – Stereo Out

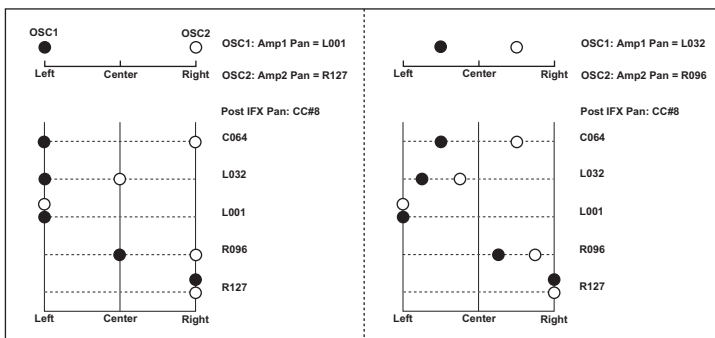

Insert Effect = Mono In - Stereo Out
Mono In - Mono Out

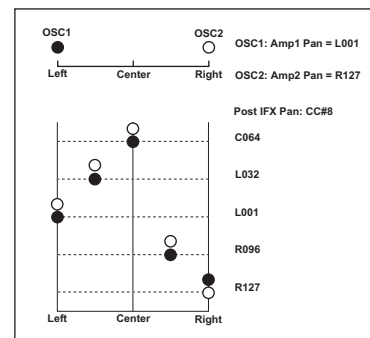

FX Ctrl (FX Control Bus)

This specifies the FX Control bus that follows the insert effect. The FX Control buses (FX Control 1, 2) are mono two-channel buses.

The microSTATION provides two (mono two-channel) effect control buses, giving you a wide range of ways to control effects.

FX Control buses can be used with vocoder, limiter, and gate-type effects.

For details on the effects that be used with FX Control buses, See “FX Control Bus” on page 207.

Send1, Send2

These parameters enable you to set the send level of the signals routed to Master Effects MFX1 and MFX2. The signal is sent in stereo to master effects MFX1 and MFX2. This is valid when “Bus (Bus Select)” is L/R or Off.

If you’re not using an insert effect:

- In Program mode, the PROG EDIT: FX Routing “OSC1 Send 1,” “OSC1 Send 2,” “OSC2 Send 1” and “OSC2 Send 2” settings will specify the send levels to the master effects.
- In Combination or Sequencer modes, the “Send 1” and “Send 2” settings of each timbre/track will specify the send levels to the master effects.

MIDI Send1 responds to CC#93 and Send2 responds to CC#91.

Controlling the Insert Effects via MIDI

Using the Dynamic Modulation (Dmod) function enables you to control all effect parameters in real-time during performance from the controllers of the microSTATION or a connected MIDI sequencer. You can also control the “Pan(CC#8),” “Send1,” and “Send2” parameters in the same way.

Program mode

You can control the parameters on the global MIDI channel (p.60).

Combination mode

The IFX1-IFX5 pages lets you specify the control channel “Ch” (Control Channel) for IFX1-IFX5. You can choose from CH01-16, Gch, or All-R (All Routed).

Ch01-16: Select this when you want to control each insert effect from a different channel. An “*” symbol will be displayed at the right of the MIDI channel Ch01-16 of the timbre that is routed to each insert effect. If the routed timbres have different MIDI channel settings, this parameter is used to specify the channel that will control the insert effect.

Gch: Select this option if you wish to control the parameters on the global MIDI channel. This is a common setting.

All-R: Select this option to control the parameters on all the channels (channels 1-16 that have a “*” mark) that are routed to the corresponding Insert Effects.

🔊 If you’ve selected a drum program for a Combination mode timbre or a Sequencer mode track, and set its “Bus” to DKit, the MIDI channel of that timbre/track will be valid if any one of IFX1-5 is set to All-R, regardless of the drum kit’s “Bus (IFX/Output)” (p.191) setting or the “DKit Patch” setting.

Sequencer mode

Use “Ch” parameters (p.46) of the IFX1 – IFX5 pages to set up the control channels for IFX1-IFX5. Select an appropriate option from Ch01-16 and All Routed.

Ch01-16: Select this when you want to control each insert effect from a different channel. An “*” symbol will be displayed at the right of the MIDI channel Ch01-16 of the track that is routed to each insert effect. If two or more tracks with differing MIDI channels Ch01-16 are being sent to a single insert effect, this parameter is used to specify the one track that will control the insert effect.

All R: Select this option to control the parameters on all the channels (channels 1-16 that have a “*” mark) that are routed to the corresponding Insert Effects. All R is a typical option. If you wish to control the parameters on a single channel, you may select it from Ch01-16.

Note: Since exclusive messages can be recorded in Sequencer mode, you can use them to automatically switch effects or modify effect parameter values during the song playback.

Master Effects (MFX1, 2)

In/Out

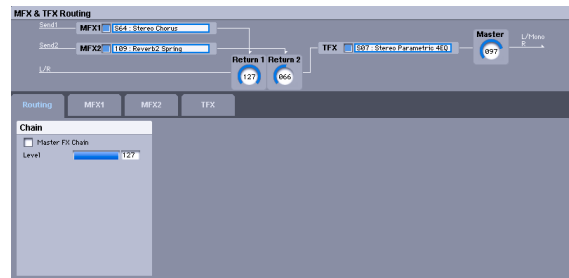

The I/Os of Master Effects MFX1 and MFX2 are stereo-in/ stereo-out. “Send1” and “Send2” determine the send level to the Master Effects. (For Send1 and 2, see “Routing” and “Mixer.”)

Master effects will not output the Dry (unprocessed) signal specified in Wet/Dry. Only the Wet (processed) signal will be output. The output signals from the Master Effects are routed to the L/R bus with the output level specified by Return1 and Return2.

This output is mixed with the L/R bus output, and then sent to the total effect.

Selecting “000: No Effect” will mute the output. The processed signal will be output in one of the following ways, according to the type of effects 001-134.

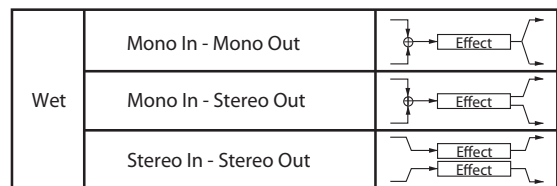

Input/output variations for each effect are shown in upper left of the block diagrams starting on page 217.

In each mode, the MFX-MFX1 and MFX2 “On/Off” parameters turn the master effects on/off. When off, the output is muted in the same way as 000: No Effect.

MIDI Separately from the setting of this On/Off button, MFX1 and MFX2 can be switched off by receiving a

MIDI control change CC#94. Value 0 will turn them off, and value 1–127 will turn them on. You can also use Effect SW (p.59) to turn MFX1 and 2 on and off. This MIDI control is performed on the global MIDI channel (p.60).

Double-size effects

Double-size effects (D00: St.MltLmt – D13: Early Ref) use twice as much space as other effects.

You can use a double-size effect for master effect MFX1. If you’ve selected a double-size effect, MFX2 won’t be available for use.

Routing

If you are not using any Insert Effects in any mode, the Master Effects send levels are determined by the “Send1” and “Send2” parameters specified independently for the oscillators (Program mode), timbres (Combination mode), tracks (Sequencer mode).

For example, since you can adjust the master effect send levels for each timbre/track, you can adjust the settings so that reverb is applied deeply to the piano, lightly to the strings, and not at all to the bass.

If you’re using insert effects, use the post-IFX “Send1” and “Send2” to adjust the send amounts.

Program mode

Use the “OSC1 Send1,” “OSC1 Send2,” “OSC2 Send1,” and “OSC2 Send2” parameters or the “Send1” and “Send2” parameters for the post-IFX1–5 signals, to set the Master Effect send level.

If you have set “Bus” to L/R or Off, “OSC1 Send1,” “OSC1 Send2,” “OSC2 Send1,” and “OSC2 Send2” (p.11) are effective. These parameters can be set for oscillators 1 and 2 individually.



If you have set “Bus” to IFX1–IFX5, “Send1” and “Send2” for the post-IFX1–5 signals are effective. If you are using the Insert Effects in chain (series), the “Send1” and “Send2” parameters for the post-IFX (last IFX) are effective. (p.210)

MIDI Send1 responds to CC#93 and Send2 responds to CC#91 on the global MIDI channel (p.60). At this time, the actual send level uses the value of the Send 1 and 2 settings for Oscillators 1 and 2, multiplied by the Send 1 and 2 values received via MIDI.

If you have selected “Drums” for Oscillator Mode (which you can edit in the microSTATION Editor/Plug-In Editor) of a Program, the “UseDKitSet” (p.11) becomes available.

If you turn on this, “Send1” and “Send2” levels for each key of the selected DrumKit become effective.

If “Bus (IFX/Output)” (p.191) is set to L/R or Off for a drum instrument key, “Send1 (to MFX1)” and “Send2(toMFX2)” (p.192) become effective.

If “Bus (IFX/Output)” is set to IFX1–5, the post-IFX1–5 “Send1” and “Send2” (p.12) become effective.

If this is off, “OSC1 Send1,” “OSC1 Send2,” “OSC2 Send1,” and “OSC2 Send2” (p.11), and the post IFX1–5 “Send1” and “Send2” (p.12) will be valid for all drum instruments, in the same way as when Oscillator Mode is Single or Double.

Combination and Sequencer modes

Use “Send1” and “Send2” (p.19, p.37) for timbres (Combination) and tracks (Sequencer) to set the Send1 and 2 levels for each timbre and track. As with Program mode, if “Bus” is set to L/R or Off, “Send1” and “Send2” become effective.

The actual levels use these Send1 and 2 level values, multiplied by the send level values of oscillators 1 and 2.

Send level

For example if you set the program’s “OSC1 Send1” to 127, “OSC1 Send2” to 064, “OSC2 Send1” to 064, “OSC2 Send2” to 127, and the combination’s “Send1” to 064 and “Send2” to 127, the actual send levels of the combination will be as follows.

- OSC1 Send1=127 (100%) *064 (50%)=064 (50%)
- OSC1 Send2=064 (50%) *127 (100%)=064 (50%)
- OSC2 Send1=064 (50%) *064 (50%)=032 (25%)
- OSC2 Send2=127 (100%) *127 (100%)=127 (100%)

If IFX1–5 is selected for “Bus,” use the “Send1” and “Send2” parameters for the post-IFX signals.

MIDI “Send1” responds to CC#93, and “Send2” responds to CC#91. If “Send1” and “Send2” for each timbre/track are effective, the parameter will be controlled on the MIDI channels set for the corresponding timbres and tracks. If the “Send1” and “Send2” parameters for the post-IFX1–5 signals are effective, they can be controlled on the MIDI channels assigned to IFX1–5.

An example for Combination mode is given below. In the following diagram, “Bus” is set so that Timbre 1 is routed to IFX1, Timbre 2 to IFX2, Timbres 3 and 4 to IFX3, Timbres 5–16 to L/R.

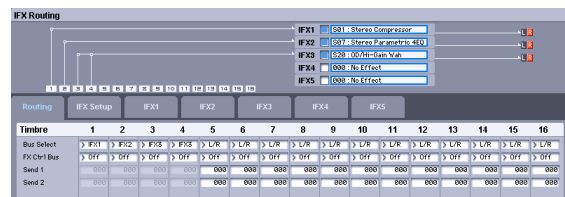

In this case, use “Send1” and “Send2” for the post-IFX1 (S01: St.Comp) signal to set the send level of the Timbre 1 routed to the Master Effect. (In this example they are set to 035 and 000.)

In the same way, use “Send1” and “Send2” for the post-IFX2 signal to set the send levels of Timbres 2, and use the “Send1” and “Send2” parameters for the post-IFX3 signal to set the send levels of Timbres 3 and 4.

For timbres 5–16, the “Send 1” and “Send 2” settings in the preceding illustration will be valid (in this case, the send levels will be the program’s “Send 1” and “Send 2” settings for each oscillator multiplied by these “Send 1” and “Send” settings).



“Bus” DKit is valid if you’ve selected a drum track for a Timbre (Combination) or Track (Sequencer).

If you select DKit, the “Bus (IFX/Output)” (p.191) settings for each key become effective, and each drum instrument sound will be routed to the corresponding buses. At this time, the actual send levels use these Send 1 and 2 values, multiplied by the Send1 and 2 settings for each DrumKit key.

If a drum kit’s “Bus (IFX/Output)” is set to L/R or Off (which you can edit in the microSTATION Editor/Plug-In Editor), the levels will be these “Send 1” and “Send 2” settings multiplied by the send levels you specify in “OSC1 Send1” and “OSC1 Send2” (p.11), just as in other cases (Oscillator Mode Single or Double).

If Bus (IFX/Output) Select is set to IFX1–5, use “Send1” and “Send2” for the post-IFX signal.

Mixer

The input levels to the master effects are determined by the send levels. In the MFX1 and MFX2 pages of each mode, you can specify the effect parameters, output level, and chaining (series connection) between the two master effects.

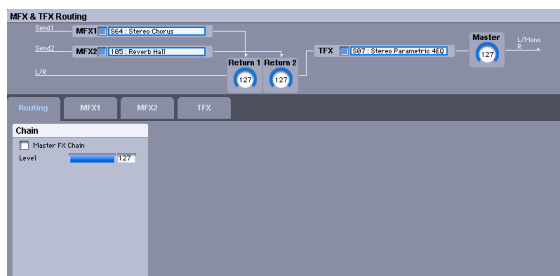

1. Return1, Return2

These adjust the amount of signal that is returned from the master effects MFX1 and MFX2 outputs to the L/R bus.

The left-side value of the Wet/Dry parameter for the MFX1 or 2 effect is the output level of that master effect. (In other words if Wet/Dry is 25:75, the output level is 75%. It is 100% if Wet, and 0% if Dry.)

The Wet/Dry value multiplied by the Return1 or Return2 value is sent to the L/R bus. This sound is then mixed with the oscillator output “Bus” L/R or the “Bus” L/R output that follows the insert effect.

For example, with MFX1 Wet/Dry set to 50:50 (50%) and Return1 set to 64 (50%), the resultant effect level will be 25%. The effect level is maximum (100%) when Wet/Dry is set to “Wet” and Return1 is set to 127.

2. Chain

If this is On, the master effects will be connected in the order of master effect 1 → master effect 2.

In the example shown in the preceding page, the output of MFX1: S64: Stereo Chorus is added to the input of MFX2: 105: Rev.Hall.

3. Chain Level

This specifies the signal level from MFX1 to MFX2 when “Chain” is on.

Controlling the Master Effects via MIDI

In the same way as for insert effects, parameters of the master effects can also be controlled in realtime via Dynamic Modulation (Dmod) from the microSTATION’s controllers or an external MIDI device during performance or from the sequencer.

Program mode

Effect parameters are controlled on the global MIDI channel (p.60).

Combination and Sequencer modes

In Combination and Sequencer modes, the control channel for MFX1 and MFX2 are specified by the Ch (Control Channel) setting in the MFX1 and 2 pages (p.25, p.46, p.155, p.173). You can choose Ch01–16 or Gch.

Ch01–16: Select this option if you wish to control the parameters for each Master Effect on different channels.

Gch: Select this option if you wish to control the parameters on the global MIDI channel (p.60). This is the normal setting.

Note: Since Sequencer mode lets you record and play exclusive messages and edit tracks that include System Exclusive events, you can use them to switch effects or modify effect parameter values during song playback.

Total Effect (TFX)

In/Out

The total effect TFX is stereo-in and stereo-out. The Dry (unprocessed) side of the Wet/Dry parameter sends the stereo input sound directly to the stereo output. The way in which the Wet (processed) side is output depends on the type of effect, as follows.

Wet	Mono In - Mono Out	
	Mono In - Stereo Out	
	Stereo In - Stereo Out	

Input/output variations for each effect are shown in upper left of the block diagrams starting on page 217.

In each mode, the TFX "On/Off" parameter turns the total effect on/off. When off, the effect is bypassed. The stereo input signal is output unchanged in stereo, just as when 000: No Effect is selected.

MIDI Separately from this On/Off button, MIDI control change CC#95 can be received to turn TFX off. A control change value of 0 turns them off, and a value of 1-127 restores them to the prior setting. You can also use Effect SW (p.59) to turn off TFX in the same way. This is controlled on the global MIDI channel (p.60).

Double-size effects

Double-size effects (D00: St.MitLmt-D13: Early Refl) can't be used for the total effect.

Routing

The total effect TFX is placed immediately before the OUTPUT L/MONO and R outputs. Effect (TFX) is available in all modes.

If the "Bus" setting for an oscillator (Program mode), timbre (Combination mode), track (Sequencer mode), or the post-insert "Bus" is set to L/R, the signal will be output from the OUTPUT L/MONO and R jacks.

The sound from MFX1 and 2 is routed through TFX, and then output to OUTPUT L/MONO and R.

Mixer

MASTER (Master Volume)

This sets the level of the final output after passing through the total effect.

Using MIDI to control the Total Effect

In the same way as for Insert and Master Effects, the Total Effect can be controlled in realtime via Dynamic Modulation (Dmod). You can use either the built-in microSTATION's controllers or an external MIDI device, during live performance or from a sequencer.

Program mode

Effect parameters are controlled on the global MIDI channel (p.60).

Combination and Sequencer modes

In Combination and Sequencer modes, the control channel for TFX is specified by the Ch (Control Channel) (p.25, p.46, p.155, p.173) setting in the TFX page. You can choose Ch01-16 or Gch.

Ch01-16: Choose from these settings if you want to control each total effect on a separate channel.

Gch: Choose this setting if you want to control the total effect on the global MIDI channel (p.60)

In Sequencer mode, you can record and play back exclusive messages, and edit tracks that include System Exclusive events. This lets you switch effects or vary the value of effect parameters while a song plays.

Main Outputs

The main L/MONO and R outputs of the microSTATION are output from the OUTPUT L/MONO, R jacks, and the headphone jack.

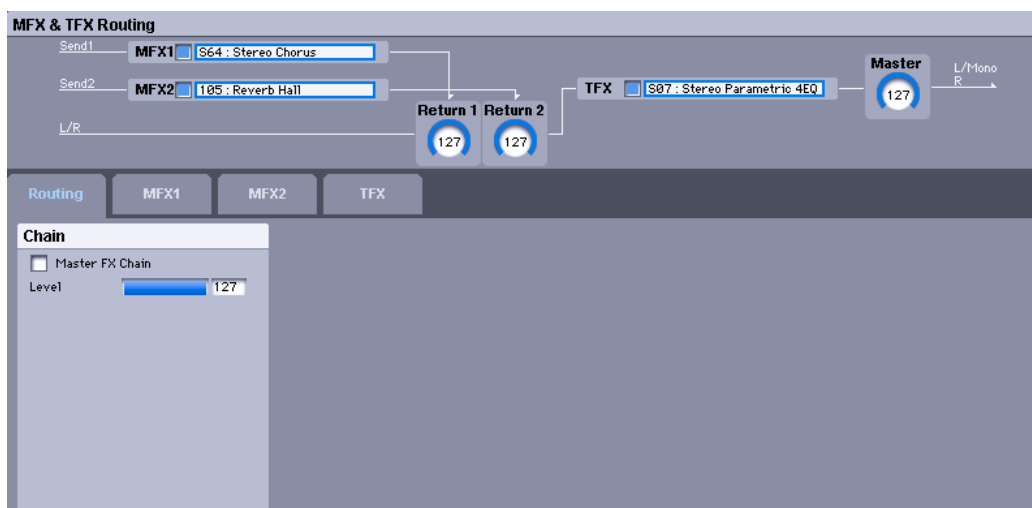

Effect/Mixer Block Diagram

Program mode

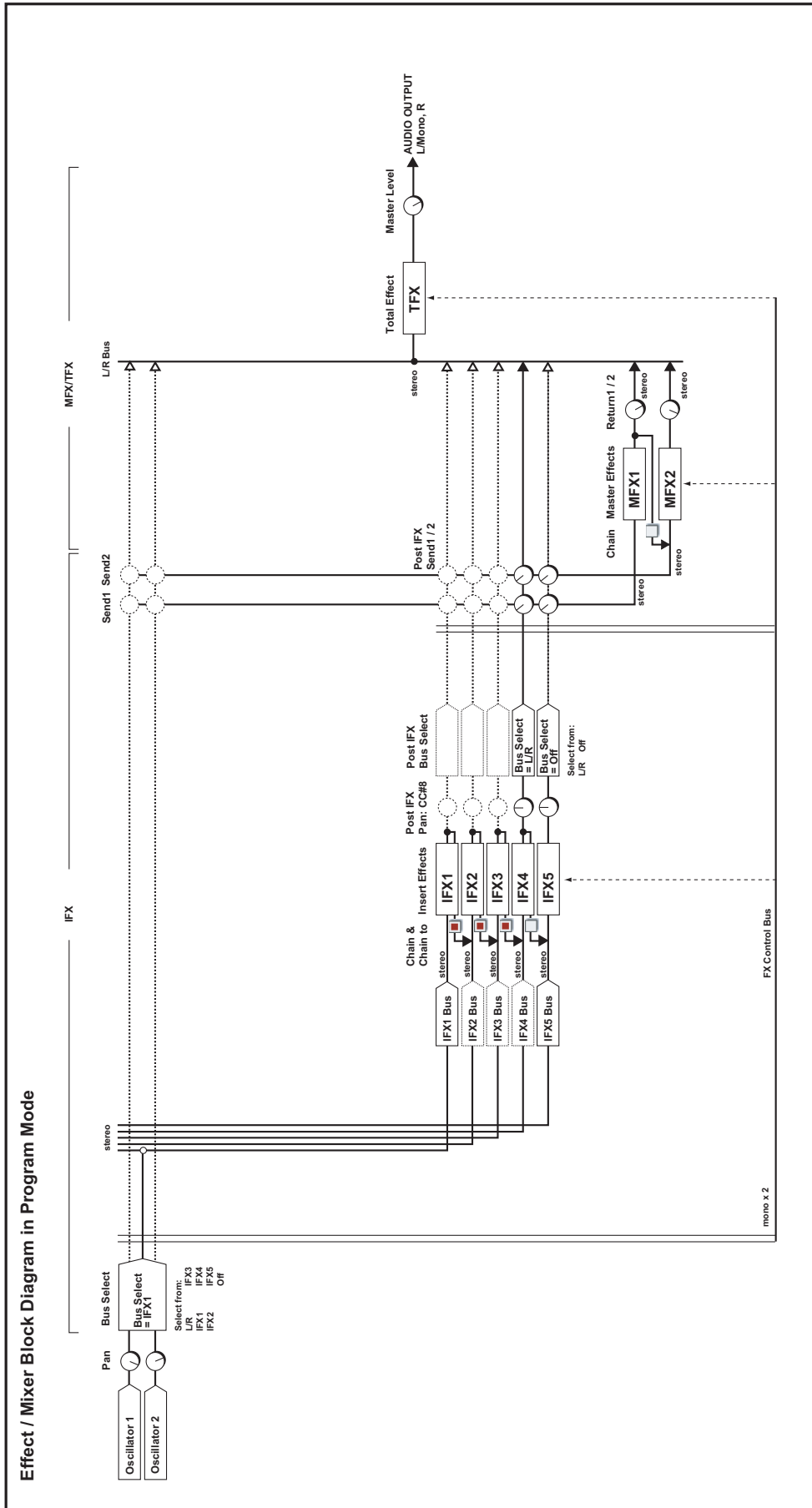

Combination, Sequencer mode

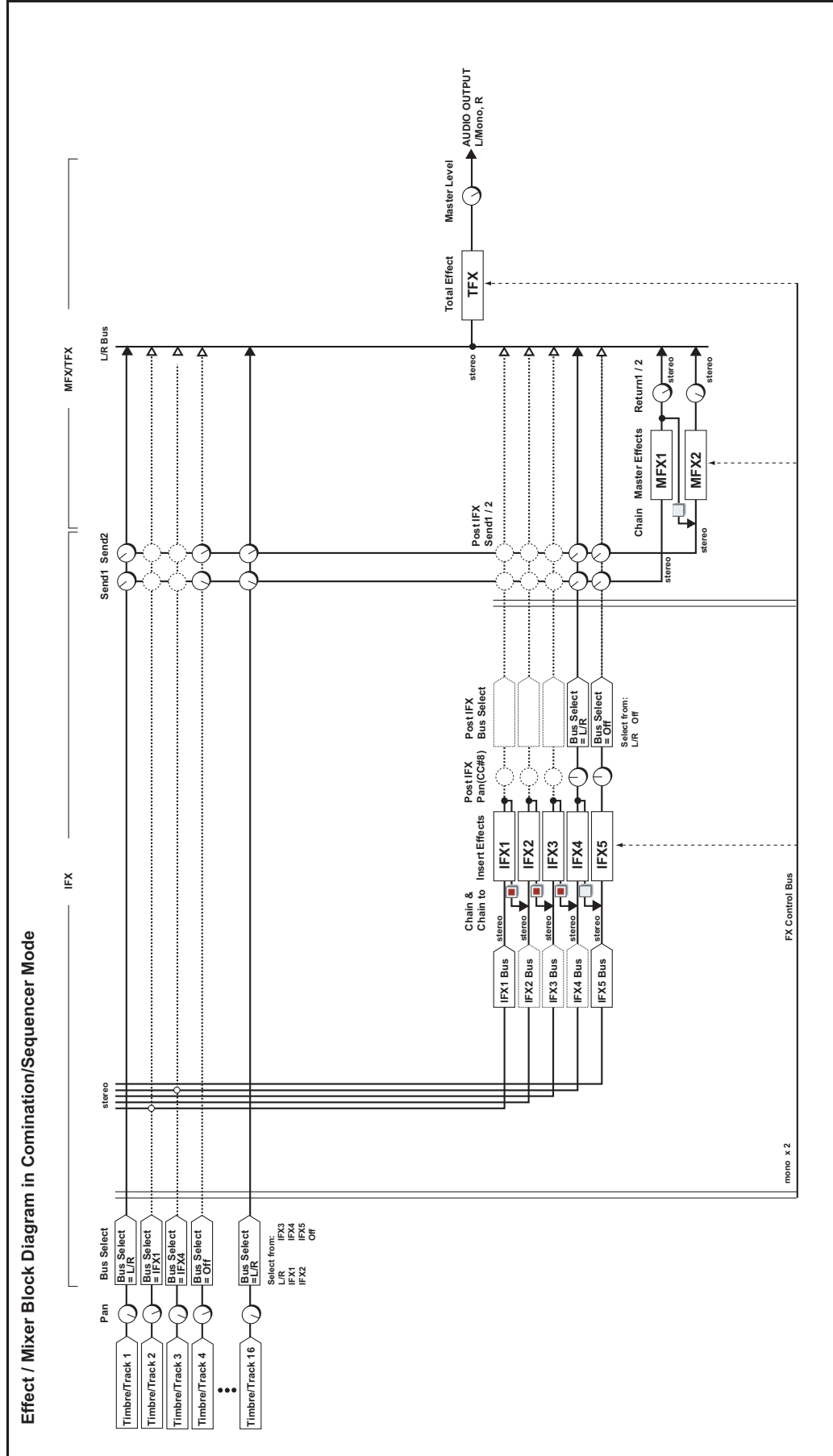

Single size effects

000: No Effect

Select this option when you do not use any effects. The Insert Effect/Total Effect section outputs unprocessed signals and the Master Effect section mutes the output.

001: St.Comp (Stereo Compressor)

This effect compresses the input signal to regulate the level and give a “punchy” effect. It is useful for guitar, piano, and drum sounds. This is a stereo compressor. You can link left and right channels, or use each channel separately.

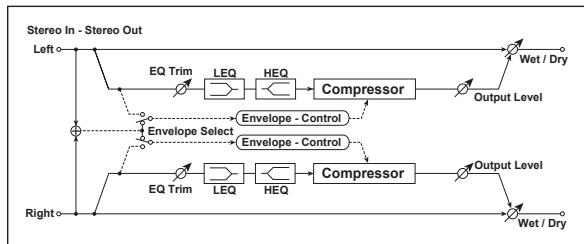

Full parameter	Quick parameter	Value	Explanation	
Envelope		L/R Mix, L/R Individually	Determines whether the left and right channels are linked or used separately p.217	
Sensitivity	Sens	1...100	Sets the sensitivity p.217	
Attack	←	1...100	Sets the attack level p.218	
EQ Trim	PreEQ Trim	0...100	Sets the EQ input level	
Lo EQ Freq		Low, Mid-Low	Selects the cutoff frequency (low or mid-low) of the low-range equalizer	
Hi EQ Freq		High, Mid-High	Selects the cutoff frequency (high or mid-high) of the high-range equalizer	
Pre LEQ Gain [dB]	LEQ [dB]	-15.0...+15.0	Sets the gain of the Low EQ	
Pre HEQ Gain [dB]	HEQ [dB]	-15.0...+15.0	Sets the gain of the High EQ	
Output Level	Out Level	0...100	Sets the output level of the compressor p.227	D ^{mod}
Source		Off...Tempo	Selects the modulation source for the compressor output level	
Amount		-100...+100	Sets the modulation amount for the compressor output level	
Wet/Dry	?	Dry, 1 : 99... 99 : 1, Wet	Sets the balance between the effect and the dry input	D ^{mod}
Source		Off...Tempo	Selects a modulation source for Wet/Dry	
Amount		-100...+100	Sets the modulation amount for Wet/Dry	

Envelope

This parameter selects whether the left and right channels are linked to control both signals simultaneously, or whether each channel is controlled independently.

Sensitivity

Output Level

The “Sensitivity” parameter sets the sensitivity of the compressor. If this parameter is set to a higher value, lower level sounds will be boosted. With a higher Sensitivity, the overall volume level is higher. To adjust the final volume level, use the “Output Level” parameter.

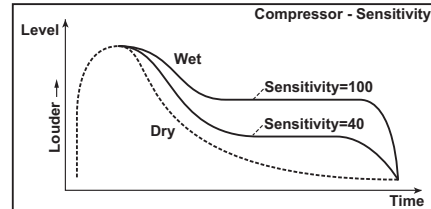

Attack

This parameter controls the attack level.

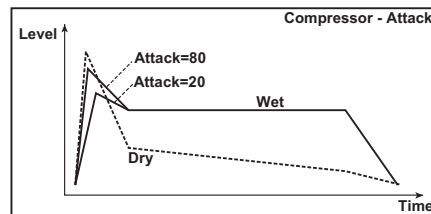

002: Red Comp

When playing chords on an electric piano or similar instrument, it’s helpful to use a compressor to keep each note smooth and well-balanced. In addition to a distinctive percussive accent, it will also provide a long sustain. This effect models a popular compressor with a clean sound that’s perfect for pop and funk music.

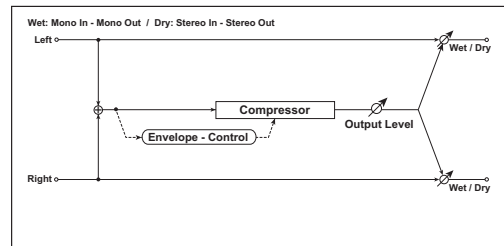

Full parameter	Quick parameter	Value	Explanation	
Sensitivity	Sens	1...100	Sets the sensitivity	
Attack	←	1...100	Sets the attack level	
Level	Out Level	0...100	Sets the output level of the compressor	
Wet/Dry	←	Dry, 1 : 99... 99 : 1, Wet	Sets the balance between the effect and the dry input	D ^{mod}
Source		Off...Tempo	Selects the modulation source for the compressor output level	
Amount		-100...+100	Sets the modulation amount for the compressor output level	

003:St. Limitr (Stereo Limiter)

The Limiter regulates the input signal level. It is similar to the Compressor, except that the Limiter compresses only signals that exceed the specified level to lower unnecessary peak signals. The Limiter applies a peaking-type EQ to the trigger signal (which controls the degree of the Limiter effect), allowing you to set any band width to be covered. This effect is a stereo limiter. You can link left and right channels, or use each channel individually.

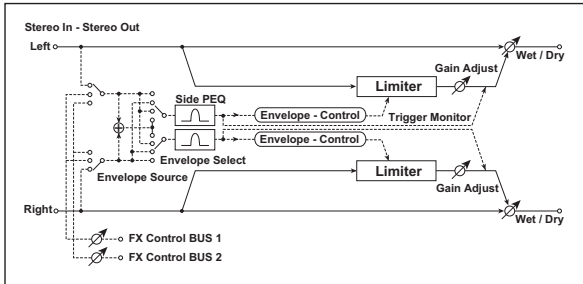

Full premiered	Quick parameter	Value	Explanation	
Envelope Source	Env Src	Input, FX Control 1, FX Control 2	Selects the trigger source to use: the input signal, FX Control Bus 1, or FX Control Bus 2 p.218	
FX Control Trim		0...100	Sets the trigger input level from FX Control Bus 1/2	
Envelope		L/R Mix, L Only, R Only, L/R Individually	Selects from linking both channels, controlling only from left channel, only from the right channel, or controlling each channel individually p.218	
Ratio	←	1.0 : 1... 50.0 : 1, Inf : 1	Sets the signal compression ratio p.218	
Threshold [dB]	Thresh[dB]	-40...0	Sets the level above which the compressor is applied p.218	
Attack	←	1...100	Sets the attack time p.218	
Release	←	1...100	Sets the release time p.218	
Gain Adjust [dB]	Gain [dB]	-Inf, -38...+24	Sets the output gain p.218	
Source		Off...Tempo	Selects the modulation source for the output gain	
Amount		-63...+63	Sets the modulation amount of the output gain	
Side PEQ PEQ Insert		Off, On	Toggles between on/off of the trigger signal's EQ p.219	
Side PEQ Trigger Monitor		Off, On	Switches between effect output monitor and trigger signal monitor p.219	
Side PEQ Cutoff [Hz]		20...12.00k	Sets the EQ center frequency for the trigger signal p.219	
Side PEQ Q		0.5...10.0	Sets the EQ bandwidth for the trigger signal p.219	
Side PEQ Gain [dB]		-18.0...+18.0	Sets the EQ gain for the trigger signal p.219	
Wet/Dry	←	Dry, 1 : 99... 99 : 1, Wet	Sets the balance between the effect and the dry input	
Source		Off...Tempo	Selects a modulation source for Wet/Dry	
Amount		-100...+100	Sets the modulation amount for Wet/Dry	

Envelope Source

By selecting FX Control 1 or FX Control 2 you can use the signal of FX Control Bus 1 or 2 as the trigger signal. For instance, you might use a different, unprocessed sound as the trigger, or apply a limiter triggered by a different timbre (Combination) or track (Sequence). For more information, please see "FX Control Bus" on page 207.

Envelope

When L/R Mix is selected for this parameter, the left and right channels are linked to control the Limiter using the mixed signal. If L Only (or R Only) is selected, the left and right channels are linked, and the Limiter is controlled via only the left (or right) channel. With L/R individually, the left and right channels control the Limiter individually.

Ratio

Threshold [dB]

Gain Adjust [dB]

This parameter sets the signal compression "Ratio." Compression is applied only when the signal level exceeds the "Threshold" value.

Adjust the output level using the "Gain Adjust" parameter, since compression causes the entire level to be reduced.

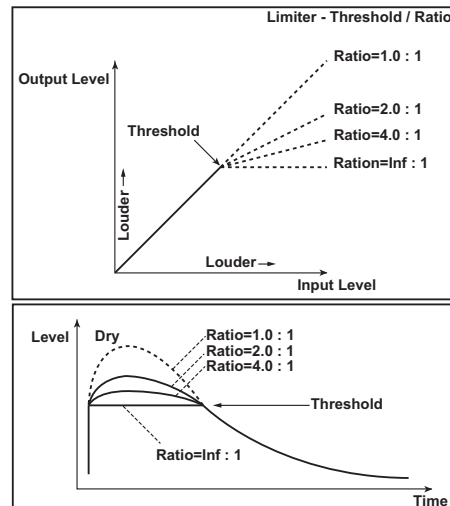

Attack

Release

These parameters set the attack time and release time. A higher attack time will cause the compression to be applied more slowly.

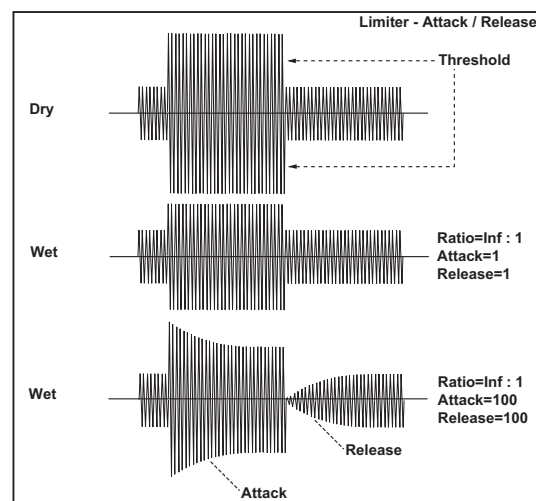

Trigger Monitor

Turning this parameter On will cause the trigger signal to be output, instead of the effect sound. Use this parameter to check the trigger signal with EQ applied. Usually, this should be set to Off.

PEQ Insert

PEQ Cutoff [Hz]

Q

Gain [dB]

These parameters are used to set the EQ amount that's applied to the trigger signal. The Limiter determines whether the compression is applied or not, based on the post-EQ trigger signal. Setting the equalizer allows you to set the Limiter to respond to any frequency band.

004: MulLimiter (Multiband Limiter)

This effect applies the Limiter to the low range, mid range, and high range of the input signal. You can control dynamics for each range to adjust the sound pressure of the low range, mid range, and high range in a different way from the EQ.

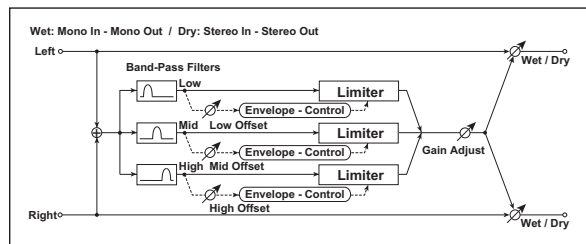

Full parameter	Quick parameter	Value	Explanation
Ratio	←	1.0 : 1...50.0 : 1, Inf : 1	Sets the signal compression ratio p.218
Threshold [dB]	Thresh[dB]	-40...0	Sets the level above which the compressor is applied p.218
Attack	←	1...100	Sets the attack time p.218
Release	←	1...100	Sets the release time p.218
Low Offset [dB]	LowOfs[dB]	-40...0	Gain of the low-range trigger signal p.219
Mid Offset [dB]	MidOfs[dB]	-40...0	Gain of the mid-range trigger signal p.219
High Offset [dB]	Hi OfS[dB]	-40...0	Gain of the high-range trigger signal p.219
Gain Adjust [dB]	Gain [dB]	-Inf, -38...+24	Sets the output gain p.218
Source		Off...Tempo	Selects the modulation source for the output gain
Amount		-63...+63	Sets the modulation amount of the output gain
Wet/Dry	←	Dry, 1 : 99... 99 : 1, Wet	Sets the balance between the effect and the dry input
Source		Off...Tempo	Selects a modulation source for Wet/Dry
Amount		-100...+100	Sets the modulation amount for Wet/Dry

Low Offset [dB]

Mid Offset [dB]

High Offset [dB]

These parameters set the gain of the trigger signal.

For example, if you do not want to apply compression to the high range, reduce the "High Offset" value down below the "Threshold" level. In this way, the high range limiter will not respond, and compression will not be applied.

005: St.MstLmt (Stereo Mastering Limiter)

This is a stereo limiter that is optimized for mastering songs.

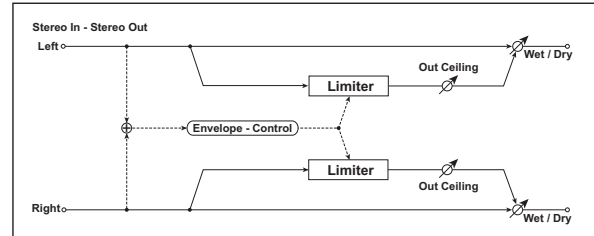

Full premiered	Quick parameter	Value	Explanation
Threshold [dB]	Trsh[dB]	-30.0...0.0	Sets the level above which the compressor is applied p.218
Out Ceiling [dB]	Ceil[dB]	-30.0...0.0	Sets the output gain
Release [ms]	Rel[ms]	0.50...1000.0	Sets the release time p.218
Wet/Dry	←	Dry, 1 : 99... 99 : 1, Wet	Sets the balance between the effect and the dry input
Source		Off...Tempo	Selects a modulation source for Wet/Dry
Amount		-100...+100	Sets the modulation amount for Wet/Dry

006: St.Gate (Stereo Gate)

This effect mutes the input signal when it falls below a specified level. You can also invert the on/off status of the gate, or use note-on/off messages to turn the gate on/off directly.

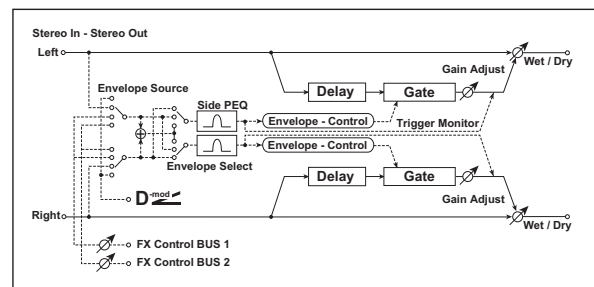

Full premiered	Quick parameter	Value	Explanation
Envelope Source	Env Src	D-mod, Input, FX Control 1, FX Control 2	Selects the source to control the gate: D-mod control, or use the input signal or FX Control Bus 1 or 2 as a trigger p.218
Fx Control Trim		0...100	Sets the trigger input level from FX Control Bus 1/2
Envelope		L/R Mix, L Only, R Only	Selects the control signal: left and right linked, left only, or right only p.218
Mid Source		Off...Tempo	Selects the source that will control the gate when Envelope Src = D-mod

Polarity		+,-	Switches the polarity of gating p.220	
Threshold	←	0...100	Sets the level where gating is applied p.220	
Attack	←	1...100	Sets the attack time p.220	
Release	←	1...100	Sets the release time p.220	
Side PEQ PEQ Insert		Off, On	Switches the trigger signal equalizer on/off p.219	
Side PEQ Trigger Monitor		Off, On	Switches between monitoring the effect output and the trigger signal p.219	
Side PEQ PEQ Cutoff [Hz]		20...12.00k	Sets the center frequency of the equalizer for the trigger signal p.219	
Side PEQ Q		0.5...10.0	Sets the bandwidth of the equalizer for the trigger signal p.219	
Side PEQ Gain [dB]		-18.0...+18.0	Sets the gain of the equalizer for the trigger signal p.219	
Wet/Dry	←	Dry, 1 : 99... 99 : 1, Wet	Sets the balance between the effect and the dry input	
Source		Off...Tempo	Selects a modulation source for Wet/Dry	
Amount		-100...+100	Sets the modulation amount for Wet/Dry	

Threshold

Attack

Release

“Threshold” specifies the level where gating occurs when “Envelope Select” is set to L/R Mix, L Only, or R Only. “Attack” and “Release” specify the attack time and release time of the gate.

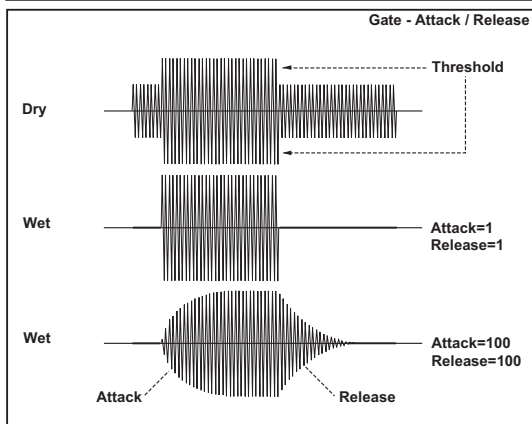
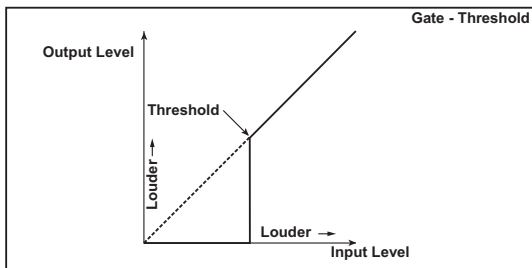

Polarity

This inverts the polarity of the gate on/off operation. With the “-” setting, the gate will close when the input signal exceeds the specified level. The direction in which the modulation source opens or closes the gate will also be reversed.

Delay Time [ms]

This sets the delay time for the input to the gate. When using shorter Attack Time settings, you can lengthen the Delay Time so that the sound is input after the gate opens.

**007: St.P4EQ
(Stereo Parametric 4-Band EQ)**

This is a stereo 4-band parametric equalizer. You can select peaking type or shelving type for Band 1 and 4. The gain of Band 2 can be controlled by dynamic modulation.

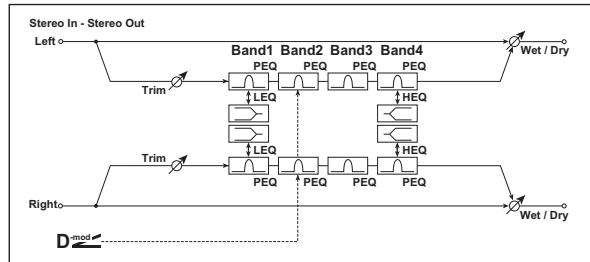

Full premiered	Quick parameter	Value	Explanation	
Trim	←	0...100	Sets the input level	
Band1 Type	B1Type	Peaking, Shelving-Low	Selects the type of Band 1 p.220	
Band4 Type	B4Type	Peaking, Shelving-High	Selects the type of Band 4 p.220	
Band2 Dynamic Gain Source		Off...Tempo	Selects the modulation source of the Band 2 gain p.221	
Amount [dB]		-18.0...+18.0	Sets the modulation amount of Band 2 gain p.221	
Band1 Cutoff [Hz]	B1 F[Hz]	20...1.00k	Sets the center frequency of Band 1	
Band1 Q	B1 Q	0.5...10.0	Sets the bandwidth of Band 1 p.221	
Band1 Gain [dB]	B1 Gain[dB]	-18.0...+18.0	Sets the gain of Band 1	
Band2 Cutoff [Hz]	B2 F[Hz]	50...10.00k	Sets the center frequency of Band 2	
Band2 Q	B2 Q	0.5...10.0	Sets the bandwidth of Band 2 p.221	
Band2 Gain [dB]	B2 Gain[dB]	-18.0...+18.0	Sets the gain of Band 2	
Band3 Cutoff [Hz]	B3 F[Hz]	300...10.00k	Sets the center frequency of Band 3	
Band3 Q	B3 Q	0.5...10.0	Sets the bandwidth of Band 3 p.221	
Band3 Gain [dB]	B3 Gain[dB]	-18.0...+18.0	Sets the gain of Band 3	
Band4 Cutoff [Hz]	B4 F[Hz]	500...20.00k	Sets the center frequency of Band 4	
Band4 Q	B4 Q	0.5...10.0	Sets the bandwidth of Band 4 p.221	
Band4 Gain [dB]	B4 Gain[dB]	-18.0...+18.0	Sets the gain of Band 4	
Wet/Dry	←	Dry, 1 : 99... 99 : 1, Wet	Sets the balance between the effect and the dry input	
Source		Off...Tempo	Selects a modulation source for Wet/Dry	
Amount		-100...+100	Sets the modulation amount for Wet/Dry	

Band1 Type

Band4 Type

Selects a filter type for Band 1 and 4.

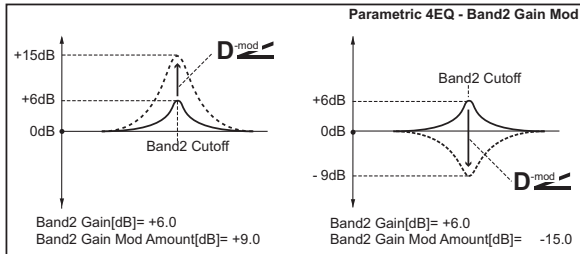
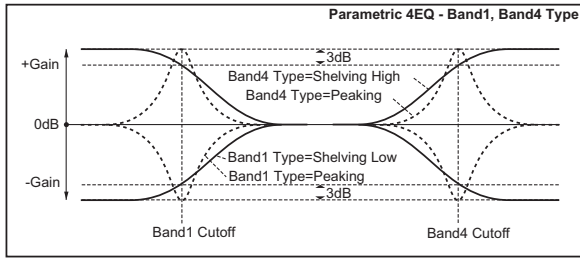

Q These parameters set the bandwidth of each equalizer. The higher the value, the narrower the band becomes.

Band2 Dynamic Gain Source Amount [dB]

You can control the gain of Band 2 using the modulation source.

008: St.G7EQ (Stereo Graphic 7-Band EQ)

This is a stereo 7-band graphic equalizer. The bar graph of the gain setting for each band gives you a clear, visual idea of frequency responses. You can select a center frequency setting for each band from twelve types, according to the sound.

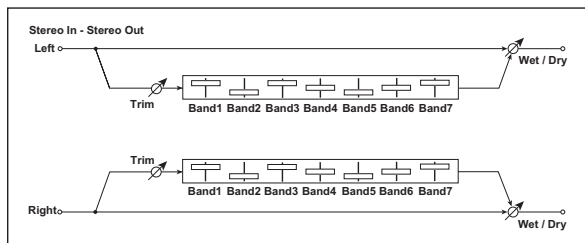

Full parameter	Quick parameter	Value	Explanation
Type	←	1:Wide 1, 2:Wide 2, 3:Wide 3, 4:Half Wide 1, 5:Half Wide 2, 6:Half Wide 3, 7:Low, 8:Wide Low, 9:Mid, 10:Wide Mid, 11:High, 12:Wide High	Selects a combination of center frequencies for each band p.221
Trim	←	0...100	Sets the input level
Band1 [dB]	B1	-18.0...+18.0	Sets the gain of Band 1
Band2 [dB]	B2	-18.0...+18.0	Sets the gain of Band 2
Band3 [dB]	B3	-18.0...+18.0	Sets the gain of Band 3
Band4 [dB]	B4	-18.0...+18.0	Sets the gain of Band 4
Band5 [dB]	B5	-18.0...+18.0	Sets the gain of Band 5
Band6 [dB]	B6	-18.0...+18.0	Sets the gain of Band 6
Band7 [dB]	B7	-18.0...+18.0	Sets the gain of Band 7

Wet/Dry	←	Dry, 1 : 99... 99 : 1, Wet	Sets the balance between the effect and the dry input	D-mod
Source		Off...Tempo	Selects a modulation source for Wet/Dry	
Amount		-100...+100	Sets the modulation amount for Wet/Dry	

Type

This parameter selects a combination of center frequencies for each band. The center frequency of each band is shown on the right side of the screen.

You can configure a 21-Band Graphic EQ ranging from 80 Hz to 18 kHz if you route three Graphic 7-Band EQ effects in series, with a setting of 7:Low, 9:Mid, and 11:High for each EQ.

009: St.Excitr (Stereo Exciter)

This effect is a combination of the Exciter.

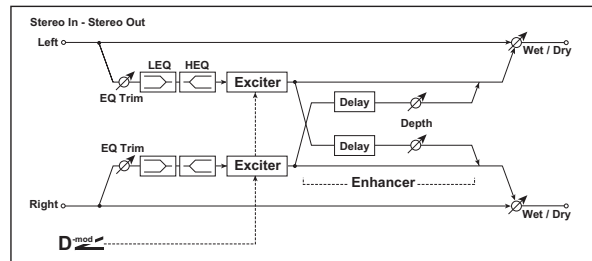

Full parameter	Quick parameter	Value	Explanation
Exciter Blend	Blend	-100...+100	Sets the intensity (depth) of the Exciter effect p.222
Source		Off...Tempo	Selects the modulation source of the Exciter intensity
Amount		-100...+100	Sets the modulation amount of the Exciter intensity
Emphasis Freq	Frequency	0...70	Sets the frequency to be emphasized p.222
Source		Off...Tempo	Selects the modulation source of the frequency to be emphasized
Amount		-70...+70	Sets the amount of modulation of the frequency to be emphasized
Source		Off...Tempo	Selects the modulation source of the Enhancer width
Amount		-100...+100	Sets the modulation amount of the Enhancer width
EQ Trim	PreEQ Trim	0...100	Sets the 2-band EQ input level
Lo EQ Freq		Low, Mid-Low	Selects the cutoff frequency (low or mid-low) of the low-range equalizer
Hi EQ Freq		High, Mid-High	Selects the cutoff frequency (high or mid-high) of the high-range equalizer
LEQ Gain [dB]	LEQ [dB]	-15.0...+15.0	Sets the gain of the Low EQ
HEQ Gain [dB]	HEQ [dB]	-15.0...+15.0	Sets the gain of the High EQ
Wet/Dry	←	Dry, 1 : 99... 99 : 1, Wet	Sets the balance between the effect and the dry input
Source		Off...Tempo	Selects a modulation source for Wet/Dry
Amount		-100...+100	Sets the modulation amount for Wet/Dry

Exciter Blend

This parameter sets the depth (intensity) of the Exciter effect. Positive values give a frequency pattern (to be emphasized) different from negative values.

Emphasis Freq

This parameter sets the frequency to be emphasized. Higher values will emphasize lower frequencies.

010: St.Isolat (Stereo Isolator)

This is a stereo effect that separates the input signal into low, mid, and high-frequency bands, and controls the volume of each band independently. For example you can separately boost or cut the kick, snare, and hi-hat sounds from a drum signal in realtime.

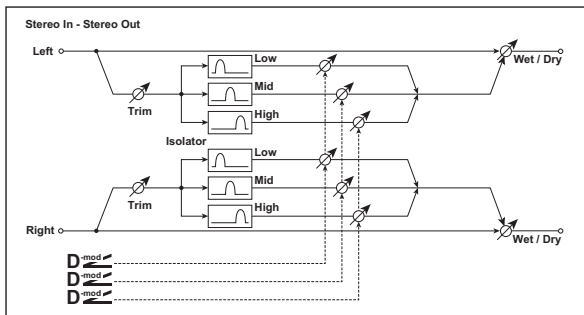

Full parameter	Quick parameter	Value	Explanation
Trim	←	0...100	Sets the input level
Low/Mid [Hz]	Lo/Mid[Hz]	100...500	Sets the frequency at which the low and mid bands are divided
Mid/High [Hz]	Mid/Hi[Hz]	2000...6000	Sets the frequency at which the mid and high bands are divided
Low Gain [dB]	Low G[dB]	-Inf, -59...+12	Sets the low-frequency gain
Low Source		Off...Tempo	Selects the source that will modulate low-frequency gain
Low Amount		-72...+72	Sets the amount by which the low-frequency gain will be modulated
Mid Gain [dB]	Mid G[dB]	-Inf, -59...+12	Sets the mid-frequency gain
Mid Source		Off...Tempo	Selects the modulation source for mid-frequency gain
Mid Amount		-72...+72	Sets the amount by which the mid-frequency gain will be modulated
High Gain [dB]	HighG[dB]	-Inf, -59...+12	Sets the high-frequency gain
High Source		Off...Tempo	Selects the modulation source for high-frequency gain
High Amount		-72...+72	Sets the amount by which the high-frequency gain will be modulated
Wet/Dry	←	Dry, 1 : 99... 99 : 1, Wet	Sets the balance between the effect and the dry input
Source		Off...Tempo	Selects a modulation source for Wet/Dry
Amount		-100...+100	Sets the modulation amount for Wet/Dry

011: St. Wah (Stereo Wah/Auto Wah)

This stereo wah effect allows you to create sounds that range from vintage wah pedal simulations to auto-wah simulations, as well as a wide variety of other settings.

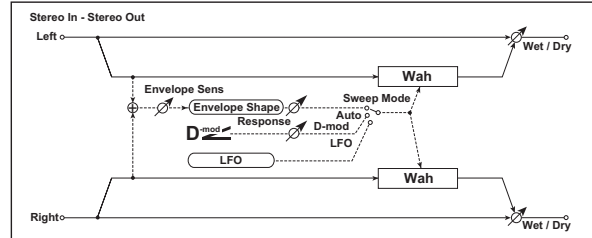

Full parameter	Quick parameter	Value	Explanation
Frequency Bottom	Freq Btm	0...100	Sets the lower limit of the wah center frequency p.223
Frequency Top	Freq Top	0...100	Sets the upper limit of the wah center frequency p.223
Sweep Mode	←	Auto, D-mod, LFO	Selects the control from auto-wah, modulation source, and LFO p.223
Source	Src	Off...Tempo	Selects the modulation source for the wah when Sweep Mode=D-mod
Respsns		0...100	Sets the response speed when Sweep Mode = Auto or D-mod
Envelope Sens		0...100	Sets the sensitivity of auto-wah p.223
Envelope Shape		-100...+100	Sets the sweep curve of auto-wah p.223
LFO Freq [Hz]	LFO [Hz]	0.02...20.00	Sets the speed of the LFO p.223
Source		Off...Tempo	Selects a modulation source for LFO speed
Amount		-20.00... +20.00	Sets the modulation amount of LFO speed
BPM/MIDI Sync	LFO MIDI Sync	Off, On	When this is on, the LFO speed is set by BPM, Base Note, and Times, instead of Frequency p.223
BPM		MIDI, 40.00... 300.00	MIDI syncs to the system tempo; 40-300 sets the tempo manually for this individual effect p.223
Base Note		♪...	Selects the type of notes that specify the LFO speed p.223
Times		x1...x32	Sets the number of notes that specify the LFO speed p.223
Resonance		0...100	Sets the resonance amount
LPF		Off, On	Switches the wah low pass filter on and off
Output Level	Out Level	0...100	Sets the output level of the effect sound
Source		Off...Tempo	Selects the modulation source that will control the effect output level
Amount		-100...+100	Sets the modulation amount of the effect output level
Wet/Dry	←	Dry, 1 : 99... 99 : 1, Wet	Sets the balance between the effect and the dry input
Source		Off...Tempo	Selects a modulation source for Wet/Dry
Amount		-100...+100	Sets the modulation amount for Wet/Dry

Frequency Bottom

Frequency Top

The sweep width and direction of the wah filter are determined by the “Frequency Top” and “Frequency Bottom” settings.

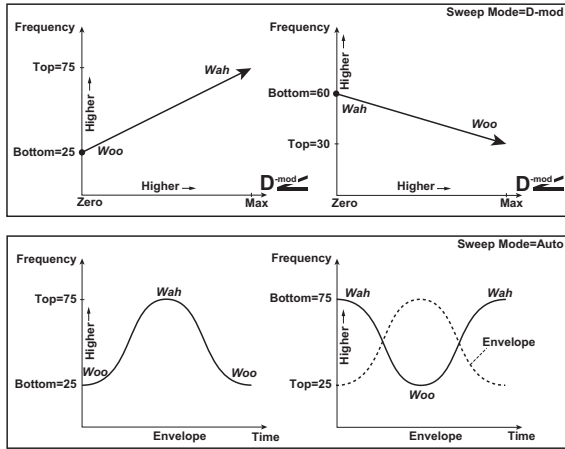

Sweep Mode

This parameter changes the wah control mode. Setting “Sweep Mode” to Auto will select an auto-wah that sweeps according to envelope changes in the input signal level. Auto-wah is frequently used for funk guitar parts and clav sounds.

When “Sweep Mode” is set to D-mod, you can control the filter directly via the modulation source in the same way as a wah pedal.

When “Sweep Mode” is set to LFO, the effect uses LFO to sweep in cycle.

Envelope Sens

This parameter sets the sensitivity of the auto-wah. Increase the value if the input signal is too low to sweep. Reduce the value if the input signal is so high that the filter is stopped temporarily.

Envelope Shape

This parameter determines the sweep curve for the auto-wah.

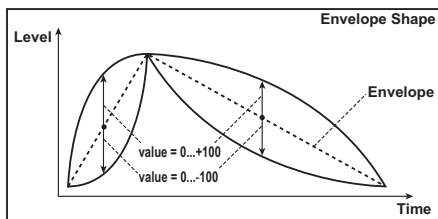

LFO Freq [Hz]

BPM/MIDI Sync

When “BPM/MIDI Sync”=Off, the LFO speed uses the “LFO Freq [Hz]” parameter setting. When “BPM/MIDI Sync”=On, the LFO speed follows the “BPM,” “Base Note,” and “Times” settings.

BPM

Base Note

Times

One cycle of LFO sweep is obtained by multiplying the length of a note (♩...) (selected for “Base Note,” in relation to the tempo specified in “BPM,” or the MIDI Clock tempo if “BPM” is set to MIDI) by the number specified in the Times parameter.

LFO Type

within the effect itself. Since this lets you use the same LFO for multiple effects, it’s useful when you want to apply various types of modulation in synchronization.

012: St.VtgWah

(Stereo Vintage/Custom Wah)

This effect simulates the tonal character of a vintage wah pedal. You can customize the tone and range settings.

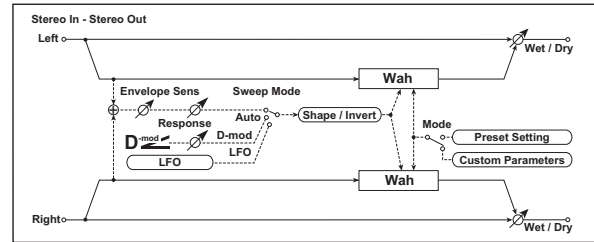

Full parameter	Quick parameter	Value	Explanation	
Mode	←	Preset, Custom	Selects either preset or custom settings p.224	
Shape		-100...+100	Sets the curve of the sweep p.224	
Invert		Off, On	Inverts the polarity of the sweep	
Frequency Bottom	CstmFrqBtm	0...100	Sets the lower limit of the wah center frequency when Mode = Custom p.224	
Frequency Top	CstmFrqTop	0...100	Sets the upper limit of the wah center frequency when Mode = Custom p.224	
Resonance Bottom	CstmResBtm	0...100	Sets the lower limit of resonance amount when Mode=Custom p.224	
Resonance Top	CstmResTop	0...100	Sets the upper limit of resonance amount when Mode=Custom p.224	
Sweep Mode	←	Auto, D-mod, LFO	Selects the control from auto-wah, modulation source, and LFO p.223	
Source	Src	Off...Tempo	Selects the modulation source for the wah when Sweep Mode=D-mod	D-mod
Manual		0...100	Sets the center frequency when Sweep Mode=D-mod and Source=Off	
Envelope Sens		0...100	Sets the auto-wah sensitivity	
Response		0...100	Sets the speed of response when Sweep Mode=Auto or D-mod	
LFO Freq [Hz]	LFO [Hz]	0.02...20.00	Sets the speed of the LFO p.223	D-mod
Source		Off...Tempo	Selects a modulation source for LFO speed	
Amount		-20.00...+20.00	Sets the modulation amount of LFO speed	
BPM/MIDI Sync	LFO MIDI Sync	Off, On	When this is on, the LFO speed is set by BPM, Base Note, and Times, instead of Frequency p.223	Sync
BPM		MIDI, 40.00...300.00	MIDI syncs to the system tempo; 40–300 sets the tempo manually for this individual effect p.223	
Base Note		♩...	Selects the type of notes that specify the LFO speed p.223	

Times		x1...x32	Sets the number of notes that specify the LFO speed p.223	
Output Level	Out Level	0...100	Sets the output level of the effect sound	
Source		Off...Tempo	Selects the modulation source that will control the effect output level	
Amount		-100...+100	Sets the modulation amount of the effect output level	
Wet/Dry	←	Dry, 1 : 99... 99 : 1, Wet	Sets the balance between the effect and the dry input	
Source		Off...Tempo	Selects a modulation source for Wet/Dry	
Amount		-100...+100	Sets the modulation amount for Wet/Dry	

Shape

This parameter specifies the sweep curve of the wah. It applies to all control via auto-wah, modulation source, and LFO, and lets you adjust subtle nuances of the wah effect.

Mode

Frequency Bottom

Frequency Top

Resonance Bottom

Resonance Top

If Mode=Preset, this simulates a vintage wah pedal. In this case, internally fixed values are used for Frequency Bottom/Top and Resonance Bottom/Top, and these settings will be ignored. The settings for Frequency Bottom/Top and Resonance Bottom/Top are valid if Mode=Custom.

013: VOX Wah

This models the legendary VOX V847 and V848 Clyde McCoy wah pedals. Its distinctive tone, sounding as though it were wrung from the throat, made this pedal a favorite of many pro musicians.

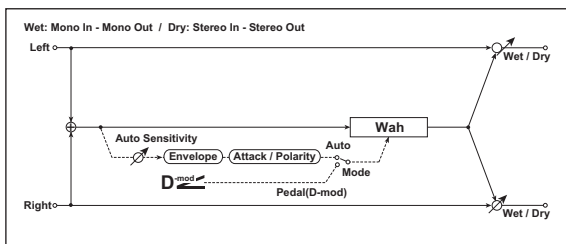

Full parameter	Quick parameter	Value	Explanation	
Type	←	V847, V848	Selects the type of wah	
Open	←	1...100	Sets the lower limit of the wah center frequency p.223	
Close	←	1...100	Sets the upper limit of the wah center frequency p.223	
Mode	SweepMode	Pedal(Dmod), Auto	Switches between pedal wah and auto-wah	
Pedal Source	Src	0...100	Specifies the modulation source that will use the pedal wah	
Pedal Manual		0...100	Sets the center frequency for the pedal wah when the modulation source is not moved	
Auto Sensitivity		0...100	Sets the auto-wah sensitivity	

Auto Polarity		Auto, D-mod, LFO	Specifies whether the auto-wah sweep is normal or inverted	
Auto Attack			Sets the auto-wah's attack speed	
Wet/Dry	←		Sets the balance between the effect and the dry input	
Source			Selects a modulation source for Wet/Dry	
Amount			Sets the modulation amount for Wet/Dry	

014: St.RndFlt (Stereo Random Filter)

This stereo band pass filter uses a step-shape waveform and random LFO for modulation. You can create a special effect from filter oscillation.

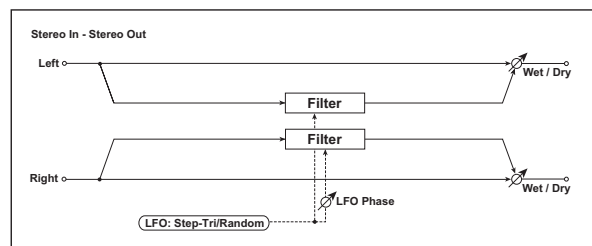

Full parameter	Quick parameter	Value	Explanation	
Manual	←	0...100	Sets the filter center frequency	
Source		Off...Tempo	Selects the modulation source for the filter center frequency	
Amount		-100...+100	Sets the modulation amount for the filter center frequency	
Depth	←	0...100	Sets the modulation depth of filter center frequency	
Source		Off...Tempo	Selects the modulation source of filter modulation	
Amount		-100...+100	Sets the modulation amount of filter modulation	
Resonance	←	0...100	Sets the resonance amount	
LFO Waveform	LFO	Step-Tri, Random	Selects the LFO Waveform p.225	
Phase [deg]		-180...+180	Sets the LFO phase difference between the left and right p.225	
LFO Freq [Hz]		0.02...20.00	Sets the speed of the LFO p.225	
Source		Off...Tempo	Selects the modulation source used for both LFO speed and step speed	
Amount		-20.00...+20.00	Sets the modulation amount of LFO speed	
Step Freq [Hz]	Step[Hz]	0.05...50.00	Sets the LFO step speed (speed that changes in steps p.225)	
Amount		-50.00...+50.00	Sets the modulation amount of LFO step speed	
BPM/MIDI Sync		Off, On	When this is on, the LFO speed is set by BPM, Base Note, and Times, instead of Frequency p.223	
BPM		MIDI, 40.00...300.00	MIDI syncs to the system tempo; 40-300 sets the tempo manually for this individual effect p.225	

Base Note			Selects the type of notes that specify the LFO speed p.225	
Times		x1...x32	Sets the number of notes that specify the LFO speed p.225	
Step Base Note			Selects the type of notes to specify the LFO step speed p.225	
Times		x1...x32	Sets the number of notes to specify the LFO step speed p.225	
Wet/Dry	←	-Wet... -1 : 99, Dry, 1 : 99...Wet	Sets the balance between the effect and the dry input p.225	
Source		Off...Tempo	Selects a modulation source for Wet/Dry	
Amount		-100...+100	Sets the modulation amount for Wet/Dry	

Phase [deg]

Offsetting the left and right phases alters how modulation is applied to the left and right channels, creating a swelling affect.

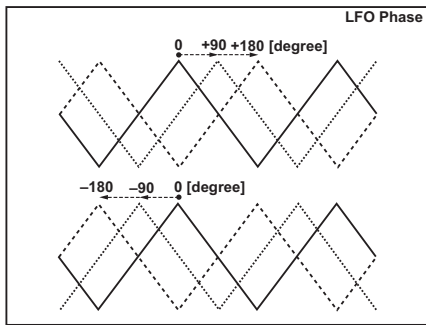

LFO Waveform

LFO Freq [Hz]

Step Freq [Hz]

When "LFO Waveform" is set to Step-Tri, LFO is a step-shape, triangle waveform. The "LFO Freq [Hz]" parameter sets the original triangle waveform speed. Changing the "Step Freq [Hz]" parameter enables you to adjust the width of the steps.

When "LFO Waveform" is set to Random, the "Step Freq [Hz]" parameter uses a random LFO cycle.

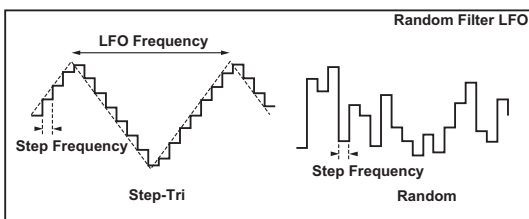

BPM

Step Base Note

Times

The width of an LFO step, or a cycle of random LFO, is obtained by multiplying the length of a note (selected for "Step Base Note," in relation to the tempo specified in "BPM," or the MIDI Clock tempo if "BPM" is set to MIDI) by the number specified in the "Times" parameter.

Wet/Dry

The effect sound's phase will be reversed when you set this parameter in the range of values from -Wet to -1.99.

015: St.MMFltr (Multi Mode Filter)

This is a multi-mode filter with four types; low pass, high pass, band pass, and band reject. You can use LFO or dynamic modulation to vary the cutoff frequency or resonance.

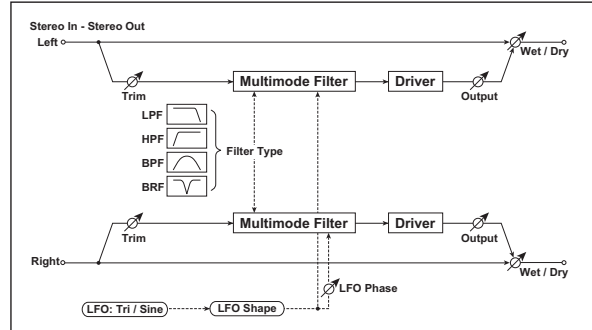

Full parameter	Quick parameter	Value	Explanation	
Filter Type	FilterType	LPF, HPF, BPF, BRF	Selects the type of filter	
Trim		0...100	Sets the input level	
Cutoff	←	0...100	Sets the cutoff frequency (center frequency)	
Source		Off...Tempo	Selects the modulation source of the cutoff	
Amount		-100...+100	Sets the modulation amount of the cutoff	
Resonance	←	0...100	Sets the resonance amount	
Source		Off...Tempo	Selects the source that will modulate the amount of resonance	
Amount		-100...+100	Sets the amount by which the resonance will be modulated	
LFO Waveform		Triangle, Sine	Selects the LFO Waveform	
Phase [deg]		-180...+180	Sets the LFO phase difference between the left and right p.225	
Depth	LFO Depth	0...100	Sets the depth of how the LFO will modulate the cutoff frequency	
LFO Freq [Hz]	LFO [Hz]	0.02...20.00	Sets the speed of the LFO p.225	
Source		Off...Tempo	Selects a modulation source for LFO speed	
Amount		-20.00...+20.00	Sets the modulation amount of LFO speed	
BPM/MIDI Sync	LFO MIDI Sync	Off, On	When this is on, the LFO speed is set by BPM, Base Note, and Times, instead of Frequency p.223	
BPM		MIDI, 40.00...300.00	MIDI syncs to the system tempo; 40-300 sets the tempo manually for this individual effect p.223	
Base Note			Selects the type of notes that specify the LFO speed p.223	
Times		x1...x32	Sets the number of notes that specify the LFO speed p.223	
Drive SW	←	Off, On	Switches distortion on/off within the filter	
Output Level	DriveLevel	0...100	Sets the output level	
Drive Gain	←	0...100	Sets the distortion amount	
Low Boost	←	0...100	Sets the amount of low-range boost	
Wet/Dry	←	Dry, 1 : 99... 99 : 1, Wet	Sets the balance between the effect and the dry input	

Source		Off...Tempo	Selects a modulation source for Wet/Dry
Amount		-100...+100	Sets the modulation amount for Wet/Dry

016: St.SubOsc (Stereo Sub Oscillator)

This effect adds very low frequencies to the input signal. It is very useful when simulating a roaring drum sound or emphasizing powerful low range. This effect is different from the equalizer in that you can add very low range harmonics. You can also adjust the oscillator frequency to match a particular note number, for use as an octaver.

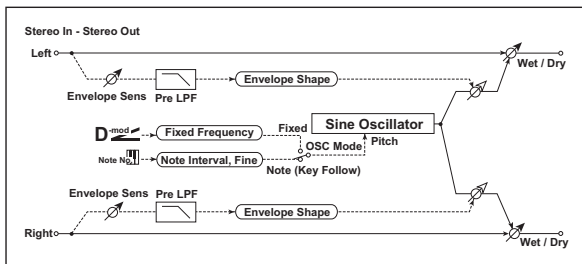

Full parameter	Quick parameter	Value	Explanation
OSC Mode	Osc	Note (Key Follow), Fixed	Determines whether the oscillator frequency follows the note number or whether it is fixed p.226
Note Interval	NoteIntrvl	-48...0	Sets the pitch difference from the note number when OSC Mode=Note (Key Follow) p.226
Note Fine	←	-100...+100	Fine adjustment of the oscillator frequency p.226
Fixed Freq [Hz]	Fixed[Hz]	10.0...80.0	Sets the oscillator frequency when OSC Mode=Fixed D-mod
Source		Off...Tempo	Selects the modulation source for the oscillator frequency when OSC Mode=Fixed
Amount		-80...+80	Sets the oscillator frequency modulation amount when OSC Mode=Fixed
Env. Pre LPF	Env Pre LPF	1...100	Sets the upper limit of the frequency range for which very low harmonics are added p.226
Env. Sens	Env Sens	0...100	Sets the sensitivity with which very low harmonics are added
Env. Shape		-100...+100	Sets the oscillator's volume envelope curve
Wet/Dry	←	Dry, 1 : 99... 99 : 1, Wet	Sets the balance between the effect and the dry input D-mod
Source		Off...Tempo	Selects a modulation source for Wet/Dry
Amount		-100...+100	Sets the modulation amount for Wet/Dry

OSC Mode

Note Interval

Note Fine

The "OSC Mode" parameter selects the oscillator operation mode. When Note (Key Follow) is selected, the oscillator's frequency is determined based on the note number, allowing you to use it as an octaver. The "Note Interval" parameter sets the pitch offset from the original note number by semitone steps. The "Note Fine" parameter allows you to fine-tune in steps of cents.

Env. Pre LPF

This parameter sets the upper limit of the frequency range where very low harmonics are added. Adjust this parameter if you do not want to add lower harmonics to the higher range.

017: Talk Mod (Talking Modulator)

This effect adds an unusual character, like a human voice, to the input signal. Modulating the tone via dynamic modulation, you can create an interesting effect that sounds as if the guitar or synthesizer is talking.

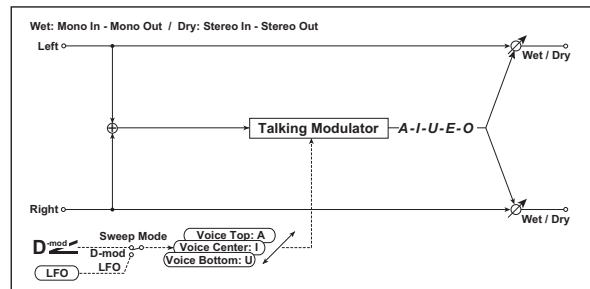

Full parameter	Quick parameter	Value	Explanation
Sweep Mode	←	D-mod, LFO	Switches between modulation source control and LFO control
Manual Voice Ctrl	Manual	Bottom, 1...49, Center, 51...99, Top	Voice pattern control
Source	Src	Off...Tempo	Selects the modulation source that controls the voice pattern D-mod
Voice Top	←	A, I, U, E, O	Selects a vowel sound at the top end of control p.227
Voice Center	←	A, I, U, E, O	Selects a vowel sound in the center of control p.227
Voice Bottom	←	A, I, U, E, O	Selects a vowel sound at the bottom end of control p.227
Formant Shift	FormntSft	-100...+100	Sets the frequency where the effect is applied p.227
Resonance		0...100	Sets the Level of resonance of the voice pattern p.227
LFO Freq [Hz]	LFO [Hz]	0.02...20.00	Sets the speed of the LFO p.223 D-mod
Source		Off...Tempo	Selects a modulation source for LFO speed
Amount		-20.00... +20.00	Sets the modulation amount of LFO speed
BPM/MIDI Sync	LFO MIDI Sync	Off, On	When this is on, the LFO speed is set by BPM, Base Note, and Times, instead of Frequency p.223
BPM		MIDI, 40.00... 300.00	MIDI syncs to the system tempo; 40-300 sets the tempo manually for this individual effect p.223
Base Note		♪...♭	Selects the type of notes that specify the LFO speed p.223
Times		x1...x32	Sets the number of notes that specify the LFO speed p.223
Wet/Dry	←	Dry, 1 : 99... 99 : 1, Wet	Sets the balance between the effect and the dry input D-mod
Source		Off...Tempo	Selects a modulation source for Wet/Dry
Amount		-100...+100	Sets the modulation amount for Wet/Dry

Voice Top

Voice Center

Voice Bottom

These parameters assign vowels to the top, center, and bottom position of the controller.

E.g.: When "Voice Top"=A, "Voice Center"=I, and "Voice Bottom"=U:

If "Sweep Mode" is set to D-mod is selected as the modulation source, moving your finger from the right to left of will change the sound from "a" to "i," then "u."

If Sweep Mode is set to LFO, the sound will change cyclically from "a" to "i," "u," "i," then "a."

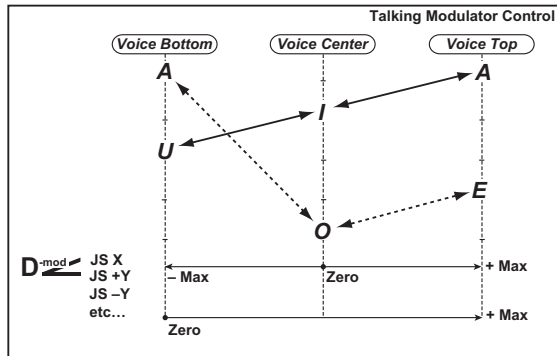

Formant Shift

This parameter adjusts the frequency level where the effect is applied. If you wish to apply the effect to a higher-range sound, set this parameter to a higher value; to apply the effect to a lower-range sound, set this to a lower value.

Resonance

This parameter sets the intensity of resonance for the voice pattern. A larger value will add more character to the sound.

018: St.Decimt (Stereo Decimator)

This effect creates a rough sound like a cheap sampler by lowering the sampling frequency and data bit length. You can also simulate noise unique to a sampler (aliasing).

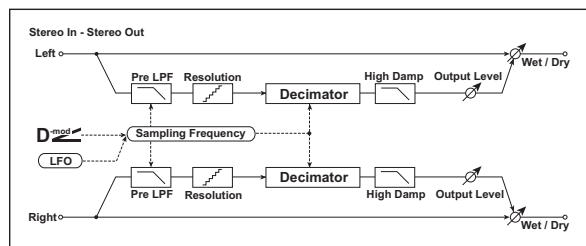

Full parameter	Quick parameter	Value	Explanation
Pre LPF	←	Off, On	Selects whether the harmonic noise caused by a decrease in sampling frequency is generated or not p.227
Sampling Freq [Hz]	F _s [Hz]	1.00k... 48.00k	Sets the sampling frequency D-mod
Source		Off...Tempo	Selects the modulation source of the sampling frequency
Amount		-48.00k... +48.00k	Sets the modulation amount of the sampling frequency
Depth	LFO Depth	0...100	Sets the depth of the sampling frequency LFO modulation D-mod
Source		Off...Tempo	Selects the LFO modulation source of the sampling frequency

Amount		-100...+100	Sets the LFO modulation amount of the sampling frequency
High Damp [%]		0...100	Sets the ratio of cut of the high range
LFO Freq [Hz]	LFO [Hz]	0.02...20.00	Sets the speed of the LFO D-mod
Source		Off...Tempo	Selects a modulation source for LFO speed
Amount		-20.00... +20.00	Sets the modulation amount of LFO speed
Resolution [bit]	Bit Reso	4...24	Sets the data bit length p.227
Output Level	OutLevel	0...100	Sets the output level p.227 D-mod
Source		Off...Tempo	Selects the modulation source for the output level
Amount		-100...+100	Sets the modulation amount of the output level
BPM/MIDI Sync	LFO MIDI Sync	Off, On	When this is on, the LFO speed is set by BPM, Base Note, and Times, instead of Frequency
BPM		MIDI, 40.00... 300.00	MIDI syncs to the system tempo; 40-300 sets the tempo manually for this individual effect
Base Note			Selects the type of notes that specify the LFO speed
Times		x1...x32	Sets the number of notes that specify the LFO speed
Wet/Dry	←	Dry, 1 : 99... 99 : 1, Wet	Sets the balance between the effect and the dry input D-mod
Source		Off...Tempo	Selects a modulation source for Wet/Dry
Amount		-100...+100	Sets the modulation amount for Wet/Dry

Pre LPF

If a sampler with a very low sampling frequency receives very high-pitched sound that could not be heard during playback, it could generate pitch noise that is unrelated to the original sound. Set "Pre LPF" to On to prevent this noise from being generated. If you set the "Sampling Fre" to about 3 kHz and set "Pre LPF" to Off, you can create a sound like a ring modulator.

Resolution [bit]

Output Level

If you set a smaller value for the "Resolution" parameter, the sound may be distorted. The volume level may also be changed. Use "Output Level" to adjust the level.

019: St. Record (Stereo Analog Record)

This effect simulates the noise caused by scratches and dust on analog records. It also reproduces some of the modulation caused by a warped turntable.

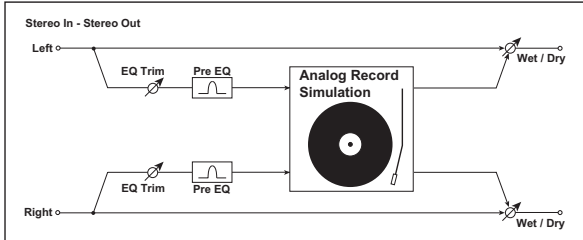

Full parameter	Quick parameter	Value	Explanation	
EQ Trim		0...100	Sets the EQ input level	
Pre EQ Cutoff [Hz]		300...10.00k	Sets the EQ center frequency	
Q		0.5...10.0	Sets the EQ band width	
Gain [dB]	PEQ [dB]	-18.0...+18.0	Sets the EQ gain	
Speed	Spd/RPM	33 1/3, 45, 78	Sets the r.p.m. of a record	
Flutter	←	0...100	Sets the modulation depth p.228	
Noise Density	Noise Dens	0...100	Sets the noise density	
Noise Tone		0...100	Sets the noise tone	
Noise Level	NoiseLevel	0...100	Sets the noise level	
Source		Off...Tempo	Selects the modulation source for the noise level	
Amount		-100...+100	Sets the modulation amount of the noise level	
Click Level	ClickLevel	0...100	Sets the click noise level p.228	
Source		Off...Tempo	Selects the modulation source for the click noise level	
Amount		-100...+100	Sets the modulation amount of the click noise level	
Wet/Dry		Dry, 1 : 99... 99 : 1, Wet	Sets the balance between the effect and the dry input	
Source		Off...Tempo	Selects a modulation source for Wet/Dry	
Amount		-100...+100	Sets the modulation amount for Wet/Dry	

Flutter

This parameter enables you to set the depth of the modulation caused by a warped turntable.

Click Level

This parameter enables you to set the level of the click noise that occurs once every rotation of the turntable. This simulation reproduces record noise, and the noise generated after the music on a vinyl record finishes.

020: OD Wah (Overdrive/Hi.Gain Wah)

This distortion effect utilizes an Overdrive mode and a Hi-Gain mode. Controlling the wah effect, the 3-band EQ, and the amp simulation will allow you to create versatile distortion sounds. This effect is suitable for guitar and organ sounds.

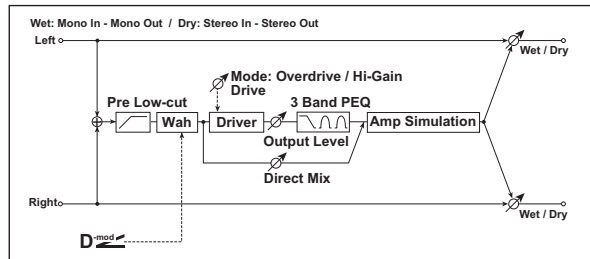

Full parameter	Quick parameter	Value	Explanation	
Wah	←	Off, On	Switches Wah on/off p.229	
Source		Off...Tempo	Selects the modulation source that switches the Wah on and off	
Switch Mode		Toggle, Moment	Selects the switching mode for the modulation source that switches the Wah on and off p.229	
Sweep Range		-10...+10	Sets the range of Wah p.229	
Source	Src	Off...Tempo	Selects the modulation source that controls the Wah p.229	
Drive Mode	Mode	Overdrive, Hi-Gain	Switches between overdrive and hi-gain distortion	
Drive	←	1...100	Sets the degree of distortion p.229	
Pre Low Cut		0...10	Sets the low range cut amount of the distortion input p.229	
Output Level	←	0...50	Sets the output level p.229	
Source		Off...Tempo	Selects the modulation source for the output level	
Amount		-50...+50	Sets the modulation amount of the output level	
Low Cutoff [Hz]		20...1.00k	Sets the center frequency for Low EQ (shelving type)	
Gain [dB]	Low G[dB]	-18...+18	Sets the gain of Low EQ	
Mid1 Cutoff [Hz]		300...10.00k	Sets the center frequency for Mid/High EQ 1 (peaking type)	
Q		0.5...10.0	Sets the band width of Mid/High EQ 1 p.221	
Gain [dB]	Mid1 G[dB]	-18...+18	Sets the gain of Mid/High EQ 1	
Mid2 Cutoff [Hz]		500...20.00k	Sets the center frequency for Mid/High EQ 2 (peaking type)	
Q		0.5...10.0	Sets the band width of Mid/High EQ 2 p.221	
Gain [dB]	Mid2 G[dB]	-18...+18	Sets the gain of Mid/High EQ 2	
Direct Mix		0...50	Sets the amount of the dry sound mixed to the distortion	
Speaker Simulation	SpeakerSim	Off, On	Switches the speaker simulation on/off	

Wet/Dry	←	Dry, 1 : 99... 99 : 1, Wet	Sets the balance between the effect and the dry input	
Source		Off...Tempo	Selects a modulation source for Wet/Dry	
Amount		-100...+100	Sets the modulation amount for Wet/Dry	

Wah

The Wah parameter switches the wah effect on/off.

Switch Mode

This parameter sets how the wah effect is switched on and off via the modulation source.

When "Switch Mode" = Moment, the wah effect is usually turned off. It is turned on only when you press the pedal or use the joystick.

MDI When a value for the modulation source is less than 64, "off" speed is selected, and when the value is 64 or higher, "on" is selected.

When "Switch Mode" = Toggle, the wah effect is switched between on and off each time you press the pedal or use the joystick.

MDI The switch will be turned on/off each time the value of the modulation source exceeds 64.

Sweep Range

Source

This parameter sets the sweep range of the wah center frequency. A negative value will reverse the direction of sweep. The wah center frequency can be controlled by the modulation source specified in the "Source" parameter.

Pre Low Cut

Cutting the signal in the low range before it is input to the Distortion will create a sharp distortion.

Drive

Output Level

The degree of distortion is determined by the level of input signal and the setting of "Drive." Raising the "Drive" setting will cause the entire volume level to increase. Use the "Output Level" parameter to adjust the volume level. The "Output Level" parameter uses the signal level input to the 3-Band EQ. If clipping occurs at the 3-Band EQ, adjust the "Output Level" parameter.

021: St.Gt Cab (Stereo Guitar Cabinet)

This simulates the acoustical character of a guitar amp's speaker cabinet.

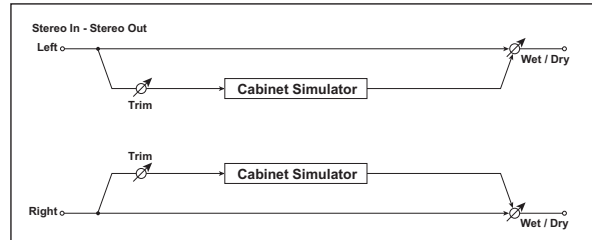

Full parameter	Quick parameter	Value	Explanation	
Trim		0..100	Sets the input level	
Type	Cab		Selects the type of the cabinet	
		TWEED - 1x12	Open-back cabinet with one 12" speaker, typically used for blues	
		TWEED - 4x10	Open-back cabinet with four 10" speakers	
		BLACK - 2x10	Open-back cabinet with two 10" speakers	
		BLACK - 2x12	American open-back cabinet with two 12" speakers	
		VOX AC15 - 1x12	Vox AC15 open-back cabinet with one 12" "Blue" speaker	
		VOX AC30 - 2x12	Vox AC30 open-back cabinet with two 12" "Blue" speakers	
		VOX AD412 - 4x12	VOX AD412 closed-back cabinet with four 12" speakers	
		UK H30 - 4x12	Closed-back classic cabinet with four 30W 12" speakers	
		UK T75 - 4x12	Closed-back cabinet with four 75W 12" speakers	
		US V30 - 4x12	Closed-back cabinet with four 30W 12" speakers	
Wet/Dry	←	Dry, 1 : 99... 99 : 1, Wet	Sets the balance between the effect and the dry input	
Source		Off...Tempo	Selects a modulation source for Wet/Dry	
Amount		-100...+100	Sets the modulation amount for Wet/Dry	

022: St.Bs Cab (Stereo Bass Cabinet)

This simulates the acoustical character of a bass amp's speaker cabinet.

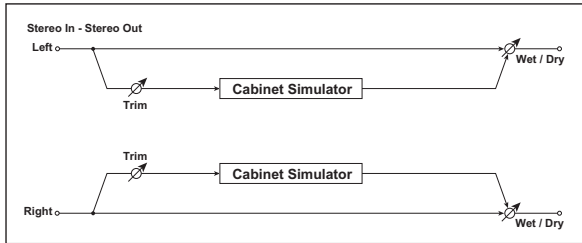

Full parameter	Quick parameter	Value	Explanation	
Trim		0...100	Sets the input level	
Cabinet Type	Cab	LA - 4x10	Four 10" speakers / LA sound cabinet	
		MODERN - 4x10	Four 10" aluminum-cone speakers / modern cabinet	
		METAL - 4x10	Four 10" aluminum-cone speakers / modern cabinet	
		CLASSIC - 8x10	Eight 10" speakers / classic cabinet	
		UK - 4x12	Four 12" speakers / UK-manufactured cabinet	
		STUDIO - 1x15	One 15" speaker / studio combo cabinet	
		JAZZ - 1x15	One 15" speaker / jazz combo cabinet	
		VOX AC100 - 2x15	Two 15" speakers / cabinet for Vox AC100	
		US - 2x15	Two 15" speakers / US-manufactured cabinet	
		UK - 4x15	Four 15" speakers / UK-manufactured cabinet	
LA - 1x18	One 18" speaker / LA sound cabinet			
COMBI - 1x12 & 1x18	One 12" and one 18" speaker combination cabinet			
Wet/Dry	←	Dry, 1 : 99... 99 : 1, Wet	Sets the balance between the effect and the dry input	
Source		Off...Tempo	Selects a modulation source for Wet/Dry	
Amount		-100...+100	Sets the modulation amount for Wet/Dry	

023: Bass Amp

This simulates a bass amp.

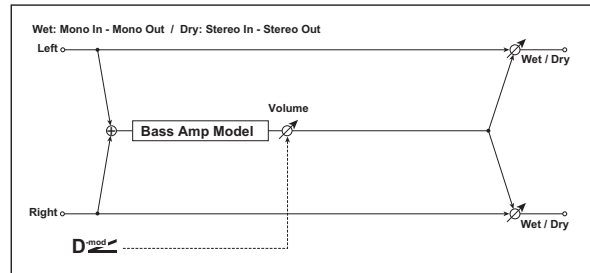

Full parameter	Quick parameter	Value	Explanation	
Type	Amp	LA STUDIO	Selects the amplifier type An amp that is typical of the LA sound.	
		JAZZ COMBO	A combo amp favored by jazz bassists.	
		GOLD PANEL	An amp distinctive for its eye-catching gold panel and clean sound.	
		SCOOPED	An amp typical of 80's sounds.	
		VALVE2	A tube amp suitable for rock.	
		VALVE	A tube amp with the ULTRA LO switch turned ON.	
		CLASSIC	A tube amp whose basic character changes according to the setting of the value dial.	
		Volume	←	0...100
Source		Off...Tempo	Selects the modulation source for the output level	
Amount		-100...+100	Sets the modulation amount of the output level	
Bass	←	0...100	Sets the bass (low range) level	
Middle	←	0...100	Sets the middle (mid range) level	
Mid Range	←	0...4	Sets the mid-frequency range	
Treble	←	0...100	Sets the treble (high range) level	
Presence	←	0...100	Sets the presence (high-frequency tone)	
Wet/Dry	←	Dry, 1 : 99... 99 : 1, Wet	Sets the balance between the effect and the dry input	
Source		Off...Tempo	Selects a modulation source for Wet/Dry	
Amount		-100...+100	Sets the modulation amount for Wet/Dry	

024: B.Amp Cab (Bass Amp Model+Cabinet)

This simulates a bass amp and speaker cabinet.

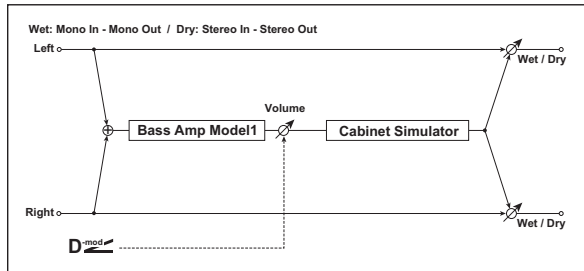

Full parameter	Quick parameter	Value	Explanation	
Amp Type	Amp	LA STUDIO, JAZZ COMBO, GOLD PANEL, SCOOPED, VALVE2, VALVE, CLASSIC	Selects the type of amplifier p.230	
Volume	←	0...100	Sets the output level	D-mod
Source		Off...Tempo	Selects the modulation source for the output level	
Amount		-100...+100	Sets the modulation amount of the output level	
Bass	←	0...100	Sets the bass (low range) level	
Middle	←	0...100	Sets the middle (mid range) level	
Mid Range	←	0...4	Sets the mid-frequency range	
Treble	←	0...100	Sets the treble (high range) level	
Presence	←	0...100	Sets the presence (high-frequency tone)	
Cabinet On	CabinetSim	Off, On	Switches the cabinet simulator on/off	
Cabinet Type	Cab	LA - 4x10, MODERN - 4x10, METAL - 4x10, CLASSIC - 8x10, UK - 4x12, STUDIO - 1x15, JAZZ - 1x15, VOX AC100 - 2x15, US - 2x15, UK - 4x15, LA - 1x18, COMBI - 1x12 & 1x18	Selects the cabinet type p.230	
Wet/Dry	←	Dry, 1 : 99... 99 : 1, Wet	Sets the balance between the effect and the dry input	D-mod
Source		Off...Tempo	Selects a modulation source for Wet/Dry	
Amount		-100...+100	Sets the modulation amount for Wet/Dry	

Amp Type Cabinet Type Recommended Combinations of Bass Amp Models and Cabinets:

Amp Type	Cabinet Type
LA STUDIO	LA - 4x10, LA - 1x18
JAZZ COMBO	JAZZ - 1x15
GOLD PANEL	MODERN - 4x10
SCOOPED	METAL - 4x10
VALVE2	CLASSIC - 8x10
VALVE	CLASSIC - 8x10
CLASSIC	COMBI - 1x12 & 1x18

025: TrebleBST (Treble Booster)

This effect models a famous boost/overdrive effect that was developed in order to produce a “guitar orchestra” effect, and designed for use with the VOX AC30. You can use this to add clear boost to the signal, or apply it to an organ sound to add an overdrive that generates rich overtones. Three controls allow a broad range of settings, letting you create a wide variety of overdrive sounds.

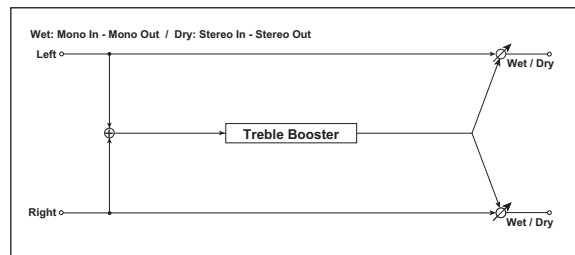

Full parameter	Quick parameter	Value	Explanation	
Drive	←	1...100	Sets the gain for overdrive	
Level	←	0...100	Sets the output level	
Tone	←	1...100	Sets the tone for overdrive	
Wet/Dry	←	Dry, 1:99 ... 99:1, Wet	Sets the balance between the effect and the dry input	D-mod
Source		Off...Tempo	Selects a modulation source for Wet/Dry	
Amount		-100...+100	Sets the modulation amount for Wet/Dry	

026: Tube Pre (Tube PreAmp Modeling)

This effect simulates a two-stage vacuum tube preamp. You can make individual settings for two vacuum tubes connected in series. This lets you create the warm sound typical of vacuum tubes.

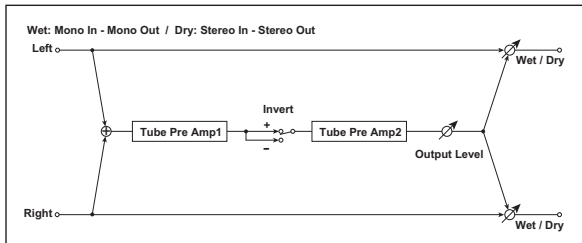

Full parameter	Quick parameter	Value	Explanation
Tube1 Low Cut [Hz]	T1 L[Hz]	Thru, 21...8.00k	Sets the cutoff frequency for the low cut filter of stage 1
Tube1 High Cut [Hz]	T1 H[Hz]	53...20.00k, Thru	Sets the cutoff frequency for the high cut filter of stage 1
Tube1 Gain [dB]	T1 G[Hz]	-24.0...+24.0	Sets the input gain for stage 1
Tube1 Saturation [%]	T1 Saturat	0...100	Sets the input/output response for stage 1 p.232
Tube1 Bias	T1 Bias	0...100	Sets the bias voltage for stage 1 p.232
Tube1 Phase	T1 Phase	Normal, Wet Invert	Turns phase reversal on/off p.232
Tube2 Low Cut [Hz]	T2 L[Hz]	Thru, 21...8.00k	Sets the cutoff frequency for the low cut filter of stage 2
Tube2 High Cut [Hz]	T2 H[Hz]	53...20.00k, Thru	Sets the cutoff frequency for the high cut filter of stage 2
Tube2 Gain [dB]	T2 G[Hz]	-24.0...+24.0	Sets the input gain for stage 2
Tube2 Saturation [%]	T2 Saturat	0...100	Sets the input/output response for stage 2 p.232
Tube2 Bias	T2 Bias	0...100	Sets the bias voltage for stage 2 p.232
Tube2 Output Level [dB]	Lvl [dB]	-48.0...+0.0	Sets the output level
Wet/Dry	←	Dry, 1 : 99... 99 : 1, Wet	Sets the balance between the effect and the dry input
Source		Off...Tempo	Selects a modulation source for Wet/Dry
Amount		-100...+100	Sets the modulation amount for Wet/Dry

Saturation [%]

With higher settings of this value, the waveform will change at high gain levels, tending to cause distortion. Lower settings of this value will produce linear response.

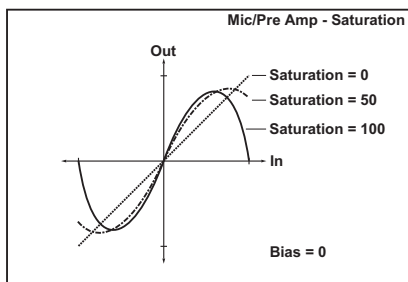

Tube1 Bias

This expresses the effect that changes in vacuum tube bias have on the distortion of the waveform. Higher settings of

this value will produce distortion even at low gain levels. Since this will also change the overtone structure, you can use it to control the tonal character.

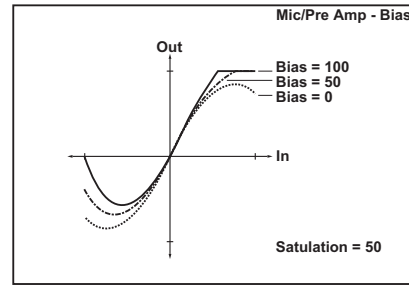

Tube1 Phase

With the Wet Invert setting, the phase of the signal will be inverted between stage 1 and stage 2. Since "Bias" is applied to the inverted signal in stage 2, this will change the tonal character.

027: St.TubPre (Stereo Tube PreAmp Modeling)

This is a stereo vacuum tube preamp simulator (See "026: Tube Pre (Tube PreAmp Modeling)" on page 232.).

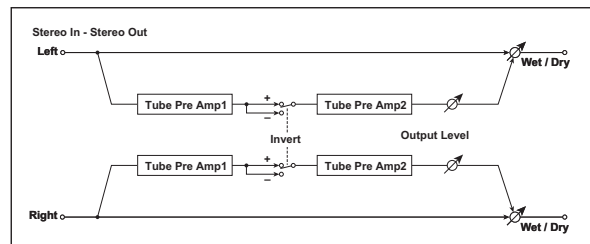

028: Mic Model (Mic Modeling + PreAmp)

This effect simulates a mic and vacuum tube preamp. You can choose from various types of mic and positions to create differing sonic characters.

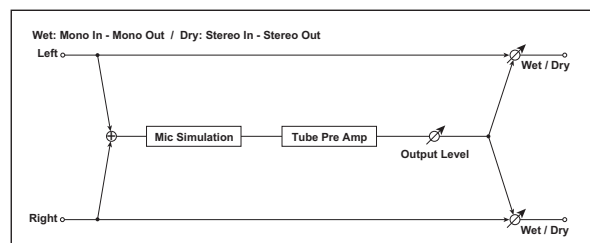

Full parameter	Quick parameter	Value	Explanation
Mic Type	Mic	Vintage Dynamic, Multi Condenser, Percussion Condenser, Drums Dynamic, Vocal Dynamic, Multi Dynamic, Vocal Condenser, Vocal Tube, Kick Dynamic	Selects the type of mic
Mic Position	Mic Posit	Close, On, Off, Far	Sets the mic placement distance p.233
Tube Low Cut [Hz]	T L[Hz]	Thru, 21...8.00k	Sets the frequency of the low cut filter

Tube High Cut [Hz]	T H[Hz]	53...20.00k, Thru	Sets the frequency of the high cut filter	
Tube Gain [dB]	T G[Hz]	-24.0...+24.0	Sets the input gain to the vacuum tube preamp	
Tube Saturation [%]	T Saturat	0...100	Sets the input/output response of the preamp p.232	
Tube Bias	T Bias	0...100	Sets the bias level of the preamp p.232	
Tube Output Level [dB]	Lvl [dB]	-48.0...+0.0	Sets the output level of the preamp	
Wet/Dry	←	Dry, 1 : 99... 99 : 1, Wet	Sets the balance between the effect and the dry input	D-mod
Source		Off...Tempo	Selects a modulation source for Wet/Dry	
Amount		-100...+100	Sets the modulation amount for Wet/Dry	

Mic Position

This expresses the effect that the mic position has on the sound. The Close setting is the closest mic position, and the Far setting is the farthest.

029: Stereo Phaser

This effect creates a swell by shifting the phase. It is very effective on electric piano sounds. You can add spread to the sound by offsetting the phase of the left and right LFOs from each other.

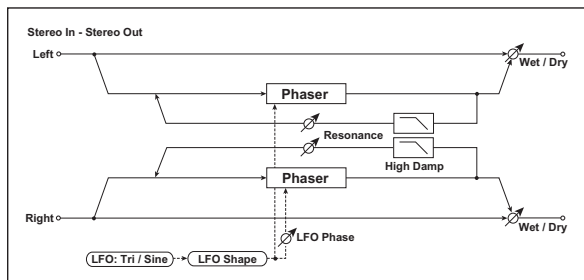

Full parameter	Quick parameter	Value	Explanation	
LFO Waveform		Triangle, Sine	Selects the LFO Waveform	
LFO Shape		-100...+100	Changes the curvature of the LFO Waveform p.224	
Phase [deg]		-180...+180	Sets the LFO phase difference between the left and right p.225	
LFO Freq [Hz]	LFO [Hz]	0.02...20.00	Sets the speed of the LFO p.223	D-mod
Source		Off...Tempo	Selects a modulation source for LFO speed	
Amount		-20.00...+20.00	Sets the modulation amount of LFO speed	
BPM/MIDI Sync	LFO MIDI Sync	Off, On	When this is on, the LFO speed is set by BPM, Base Note, and Times, instead of Frequency p.223	ASIO
BPM		MIDI, 40.00...300.00	MIDI syncs to the system tempo; 40-300 sets the tempo manually for this individual effect p.223	
Base Note			Selects the type of notes that specify the LFO speed p.223	
Times		x1...x32	Sets the number of notes that specify the LFO speed p.223	
Manual	←	0...100	Sets the frequency where the effect is applied	D-mod

Source		Off...Tempo	Selects the modulation source for the LFO modulation	
Amount		-100...+100	Sets the modulation amount of the LFO modulation	
Depth	←	0...100	Sets the depth of LFO modulation	D-mod
Source		Off...Tempo	Selects the modulation source for the LFO modulation depth	
Amount		-100...+100	Sets the modulation amount of the LFO modulation depth	
Resonance	←	-100...+100	Sets the resonance amount p.233	
High Damp [%]		0...100	Sets the resonance damping amount in the high range p.233	
Wet/Dry	←	-Wet...-1 : 99, Dry, 1 : 99...Wet	Sets the balance between the effect and the dry input p.225, p.233	D-mod
Source		Off...Tempo	Selects a modulation source for Wet/Dry	
Amount		-100...+100	Sets the modulation amount for Wet/Dry	

Resonance

Wet/Dry

The peak shape of the positive and negative Feedback value is different. The harmonics will be emphasized when the effect sound is mixed with the dry sound, if you set a positive value for both "Resonance" and "Wet/Dry," and if you set a negative value for both "Resonance" and "Wet/Dry."

High Damp [%]

This parameter sets the amount of damping of the resonance in the high range. Increasing the value will cut high-range harmonics.

030: Small Phs (Small Phaser)

This models a classic phaser that was born in New York during the 1970s. With a warm, rich tone, it is also loved by many electric piano players.

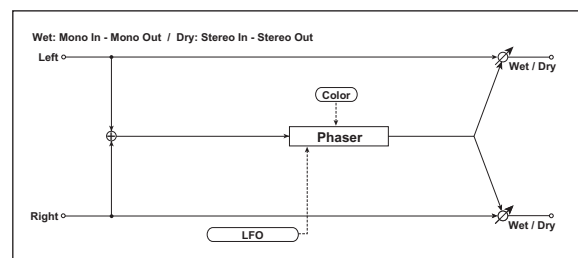

Full parameter	Quick parameter	Value	Explanation	
Speed [Hz]	←	0.10...10.0	Sets the speed of the LFO	
Color	←	Off, On	Switches the tone of the phaser sound p.233	
Wet/Dry	←	-Wet...-1 : 99, Dry, 1 : 99...Wet	Sets the balance between the effect and the dry input p.225, p.233	D-mod
Source		Off...Tempo	Selects a modulation source for Wet/Dry	
Amount		-100...+100	Sets the modulation amount for Wet/Dry	

Color

This lets you choose between two types of phaser sound. Turning this On produces a deeper phase shift effect with a distinctive modulation.

031: OrangePhs (Orange Phaser)

This models a standard model of analog phaser that achieved great popularity. It gives a sense of movement to electric piano sounds, adding a rich-sounding phase shift effect.

032: BlackPhsr (Black Phaser)

This models a Danish-made four-stage phaser that featured a wide range.

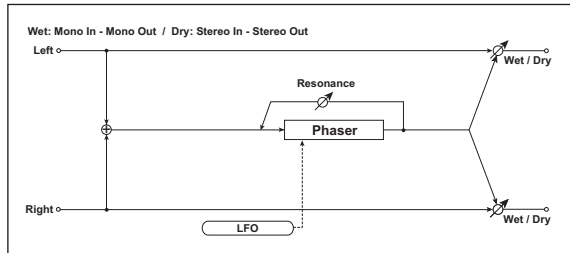

Full parameter	Quick parameter	Value	Explanation	
Speed [Hz]	←	0.10...10.0	Sets the speed of the LFO	
Depth	←	0...100	Sets the depth of LFO modulation	
Resonance	←	0...100	Sets the resonance amount	
Manual	←	1...100	Sets the frequency where the effect is applied	
Wet/Dry	←	-Wet...-1 : 99, Dry, 1 : 99...Wet	Sets the balance between the effect and the dry input	
Source		Off...Tempo	Selects a modulation source for Wet/Dry	
Amount		-100...+100	Sets the modulation amount for Wet/Dry	

033: U-VIBE

This models a famous chorus/vibrato pedal effect. Simulating a rotary speaker, this effect produced a fascinatingly lush tone.

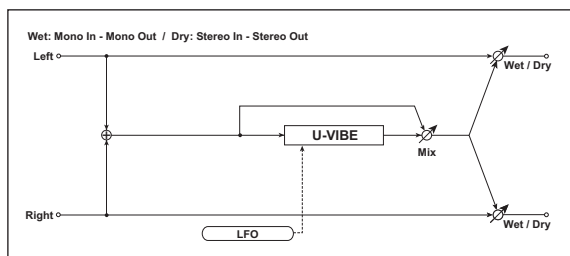

Full parameter	Quick parameter	Value	Explanation	
Speed [Hz]	←	0.10...10.0	Sets the speed of the vibration	
Depth	←	0...100	Sets the depth of vibration	
Mix	←	0...100	Sets the effect mix level	
Wet/Dry	←	-Wet...-1 : 99, Dry, 1 : 99...Wet	Sets the balance between the effect and the dry input	
Source		Off...Tempo	Selects a modulation source for Wet/Dry	
Amount		-100...+100	Sets the modulation amount for Wet/Dry	

Mix Wet/Dry

The Mix parameter specifies the amount of effect sound relative to the direct sound. A setting of 0 produces the direct sound, a setting of about 50 produces chorus, and a setting of 100 produces a vibrato effect. If you set the Wet/Dry parameter to Wet, the sound will be output with the mix balance specified by Mix.

034: St.RndPhs (Stereo Random Phaser)

This is a stereo phaser. The effect uses a step-shape waveform and random LFO for modulation, creating a unique phasing effect.

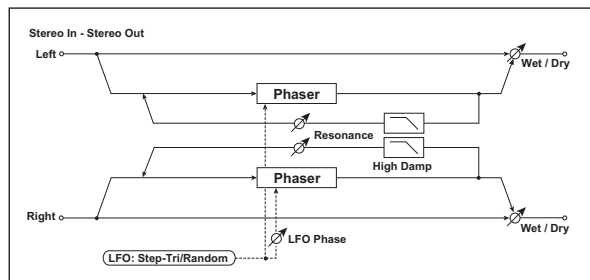

Full parameter	Quick parameter	Value	Explanation	
Manual	←	0...100	Sets the frequency where the effect is applied	
Source		Off...Tempo	Selects the modulation source for the LFO modulation	
Amount		-100...+100	Sets the modulation amount of the LFO modulation	
Depth		0...100	Sets the depth of LFO modulation	
Resonance		-100...+100	Sets the resonance amount	p.233
High Damp [%]		0...100	Sets the resonance damping amount in the high range	p.233
LFO Waveform	LFO	Step-Tri, Step-Sin, Random	Selects the LFO Waveform	p.225
Phase [deg]		-180...+180	Sets the LFO phase difference between the left and right	p.225
LFO Freq [Hz]		0.02...20.00	Sets the speed of the LFO	p.223
Source		Off...Tempo	Selects the modulation source commonly used for LFO speed and step speed	
Amount		-20.00...+20.00	Sets the modulation amount of LFO speed	
Step Freq [Hz]	Step [Hz]	0.05...50.00	Sets the LFO step speed	p.225
Amount		-50.00...+50.00	Sets the modulation amount of LFO step speed	
BPM/MIDI Sync	LFO MIDI Sync	Off, On	When this is on, the LFO speed is set by BPM, Base Note, and Times, instead of Frequency	p.223
BPM		MIDI, 40.00...300.00	MIDI syncs to the system tempo; 40-300 sets the tempo manually for this individual effect	p.223
Base Note			Selects the type of notes that specify the LFO speed	p.223

Times		x1...x32	Sets the number of notes that specify the LFO speed p.223	
Step Base Note			Selects the type of notes to specify the LFO step speed p.223	
Times		x1...x32	Sets the number of notes to specify the LFO step speed p.223	
Wet/Dry	←	-Wet... -1 : 99, Dry, 1 : 99...Wet	Sets the balance between the effect and the dry input p.225, p.233	
Source		Off...Tempo	Selects a modulation source for Wet/Dry	
Amount		-100...+100	Sets the modulation amount for Wet/Dry	

035: St.EnvPhs (Stereo Envelope Phaser)

This stereo phaser uses an envelope generator for modulation. You will obtain the same pattern of phasing each time you play. You can also control the Phaser directly using the modulation source.

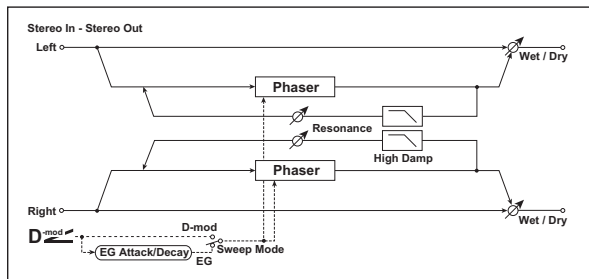

Full parameter	Quick parameter	Value	Explanation	
L Manual Bottom	L Manu Btm	0...100	Sets the lower limit of the frequency range for the effect on the left channel	
L Manual Top	L Manu Top	0...100	Sets the upper limit of the frequency range for the effect on the left channel	
R Manual Bottom	R Manu Btm	0...100	Sets the lower limit of the frequency range for the effect on the right channel	
R Manual Top	R Manu Top	0...100	Sets the upper limit of the frequency range for the effect on the right channel	
Sweep Mode	←	EG, D-mod	Determines whether the flanger is controlled by the envelope generator or by the modulation source p.255	
Source	Src	Off...Tempo	Selects the modulation source that triggers the EG (when EG is selected for Sweep Mode), or modulation source that causes the flanger to sweep (when D-mod is selected for Sweep Mode) p.255	
EG Attack	←	1...100	Sets the EG attack speed p.256	
EG Decay	←	1...100	Sets the EG decay speed p.256	
Resonance	←	-100...+100	Sets the resonance amount p.233	
High Damp [%]		0...100	Sets the resonance damping amount in the high range p.233	

Wet/Dry	←	-Wet... -1 : 99, Dry, 1 : 99...Wet	Sets the balance between the effect and the dry input p.225, p.233	
Source		Off...Tempo	Selects a modulation source for Wet/Dry	
Amount		-100...+100	Sets the modulation amount for Wet/Dry	

036: 2Vo.Reso (2Voice Resonator)

This effect resonates the input signal at a specified pitch. You can set the pitch, output level, and pan settings for two resonators individually. You can control the resonance intensity via an LFO.

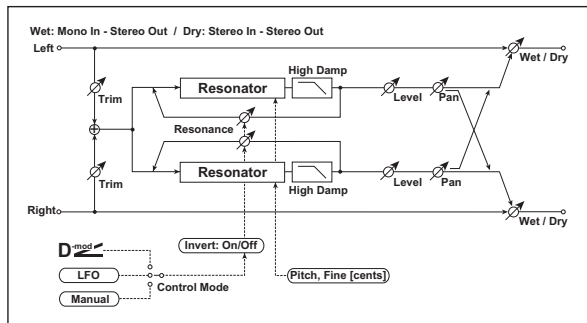

Full parameter	Quick parameter	Value	Explanation	
Control Mode	Control	Manual, LFO, D-mod	Switches the controls of resonance intensity p.236	
LFO/D-mod Invert	Mod Invert	Off, On	Reverses the Voice 1 and 2 control when LFO/D-mod is selected p.236	
LFO Freq [Hz]	LFO [Hz]	0.02...20.00	Sets the speed of the LFO	
Dmod Source	Src	Off...Tempo	Selects the modulation source that controls resonance intensity	
BPM/MIDI Sync	LFO MIDI Sync	Off, On	When this is on, the LFO speed is set by BPM, Base Note, and Times, instead of Frequency p.223	
BPM		MIDI, 40.00...300.00	MIDI syncs to the system tempo; 40-300 sets the tempo manually for this individual effect p.223	
Base Note			Selects the type of notes that specify the LFO speed p.223	
Times		x1...x32	Sets the number of notes that specify the LFO speed p.223	
Mod. Depth	←	-100...+100	Sets the amount of resonance intensity control via LFO/D-mod	
Trim	←	0...100	Sets the input level at the resonator	
Voice1 Pitch	V1 Pitch	C0...B8	Sets the voice1 Pitch for resonance p.236	
Voice1 Fine [cents]		-50...+50	Fine-adjusts the voice 1 pitch for resonance p.236	
Voice1 Level	V1 Level	0...100	Sets the Voice1 output level	
Voice1 Resonance	V1 Reso	-100...+100	Sets the intensity of resonance when Control Mode = Manual p.236	
Voice1 High Damp [%]		0...100	Sets the damping amount of resonant sound in the high range p.236	
Voice1 Pan		L6...L1, C, R1...R6	Sets the Voice1 stereo image	

Voice2 Pitch	V2 Pitch	C0...B8	Sets the voice 2 Pitch for resonance p.236
Voice2 Fine [cents]		-50...+50	Fine-adjusts the voice 2 pitch for resonance p.236
Voice2 Level	V2 Level	0...100	Sets the Voice2 output level
Voice2 Resonance	V2 Reso	-100...+100	Sets the intensity of resonance when Control Mode = Manual p.236
Voice2 High Damp [%]		0...100	Sets the damping amount of resonant sound in the high range p.236
Voice2 Pan		L6...L1, C, R1...R6	Sets the Voice2 stereo image
Wet/Dry	←	Dry, 1 : 99... 99 : 1, Wet	Sets the balance between the effect and the dry input 
Source		Off...Tempo	Selects a modulation source for Wet/Dry
Amount		-100...+100	Sets the modulation amount for Wet/Dry

Control Mode

Voice 1 Resonance

Voice 2 Resonance

This parameter determines the resonance intensity. When "Control Mode" = Manual, the "Resonance" parameter sets the intensity of resonance. If the "Resonance" parameter has a negative value, harmonics will be changed, and resonance will occur at a pitch one octave lower. When "Control Mode" = LFO, the intensity of resonance varies according to the LFO. The LFO sways between positive and negative values, causing resonance to occur between specified pitches an octave apart in turn. When "Control Mode" = D-mod, the resonance is controlled by the dynamic modulation source. If JS X is assigned as the modulation source, the pitch an octave higher and lower can be controlled, similar to when LFO is selected for Control Mode.

LFO/D-mod Invert

When "Control Mode" = LFO or D-mod, the controlled phase of either Voice 1 or 2 will be reversed. When the resonance pitch is set for Voice 1 (Resonance has a positive value), Voice 2 will resonate at a pitch an octave below (Resonance has a negative value).

Voice 1 Pitch

Voice 1 Fine [cents]

Voice 2 Pitch

Voice 2 Fine [cents]

The Pitch parameter specifies the pitch of resonance by note name. The "Fine" parameter allows for fine adjustment in steps of cents.





High Damp [%]

This sets the amount of damping amount for the high frequencies of the resonant sound. Lower values create a metallic sound with a higher range of harmonics.

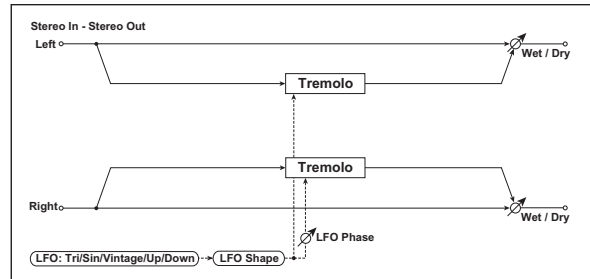
037: St.Tremlo (Stereo Tremolo)

This effect modulates the volume level of the input signal. The effect is stereo, and offsetting the LFO of the left and right phases from each other produces a tremolo effect between left and right.



Full parameter	Quick parameter	Value	Explanation
Depth	←	0...100	Sets the depth of LFO modulation 
Source		Off...Tempo	Selects the modulation source of the depth of modulation
Amount		-100...+100	Sets the modulation amount of the depth of modulation
LFO Waveform	LFO	Triangle, Sine, Vintage, Up, Down	Selects the LFO Waveform p.236
LFO Shape		-100...+100	Changes the curvature of the LFO Waveform p.224
LFO Phase [deg]		-180...+180	Sets the LFO phase difference between the left and right p.237
LFO Freq [Hz]	LFO [Hz]	0.02...20.00	Sets the speed of the LFO p.225 
LFO Source		Off...Tempo	Selects a modulation source for LFO speed
LFO Amount		-20.00... +20.00	Sets the modulation amount of LFO speed
LFO BPM/MIDI Sync	LFO MIDI Sync	Off, On	When this is on, the LFO speed is set by BPM, Base Note, and Times, instead of Frequency p.223 
LFO BPM		MIDI, 40.00... 300.00	MIDI syncs to the system tempo; 40-300 sets the tempo manually for this individual effect p.223
LFO Base Note			Selects the type of notes that specify the LFO speed p.223
LFO Times		x1...x32	Sets the number of notes that specify the LFO speed p.223
Wet/Dry	←	Dry, 1 : 99... 99 : 1, Wet	Sets the balance between the effect and the dry input 
Source		Off...Tempo	Selects a modulation source for Wet/Dry
Amount		-100...+100	Sets the modulation amount for Wet/Dry

LFO Waveform

This parameter sets the basic shape of the LFO. The **Vintage** waveform models classic guitar-amp tremolo.

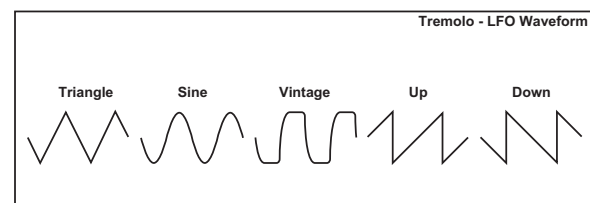

LFO Phase [deg]

This parameter determines the difference between the left and right LFO phases. A higher value will simulate the auto-pan effect in which the sound is panned between left and right.

038: TEX Treml (TEX Tremolo)

This models the highly-acclaimed tremolo circuit that was built into a US-made combo amp. The Spread setting lets you create a pan effect that wavers between left and right.

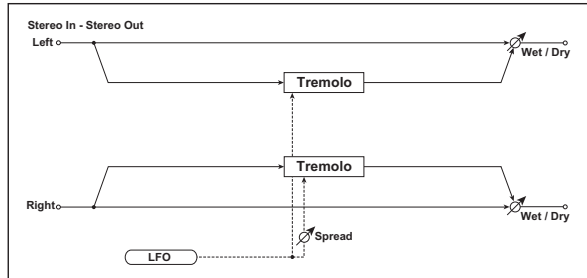

Full parameter	Quick parameter	Value	Explanation	
Speed [Hz]	←	0.10...10.0	Sets the tremolo speed	
Depth	←	0...100	Select the tremolo depth	
Spread	←	0...100	Sets the width of the stereo image of the effect sound	
Level Adjust		1...100	Sets the output level	
Wet/Dry	←	-Wet... -1 : 99, Dry, 1 : 99...Wet	Sets the balance between the effect and the dry input	D ^{mod}
Source		Off...Tempo	Selects a modulation source for Wet/Dry	
Amount		-100...+100	Sets the modulation amount for Wet/Dry	

039: St. Env.Trm (Stereo Envelope Tremolo)

This effect uses the input signal level to modulate a stereo tremolo (LFO volume modulation). For instance, you can create a tremolo effect that becomes deeper and faster as the input gets more quiet.

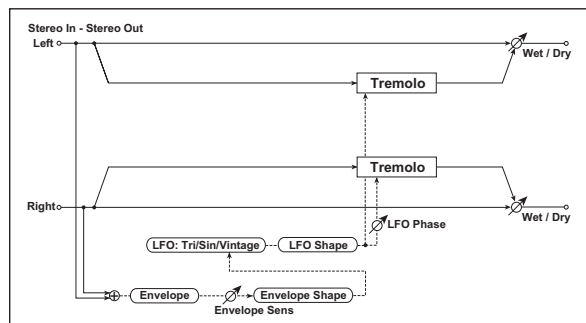

Full parameter	Quick parameter	Value	Explanation	
Envelope Sens	Env Sens	0...100	Sets the envelope's sensitivity to the input signal	
Envelope Shape		-100...+100	Sets the envelope's curvature	
LFO Waveform		Triangle, Sine, Vintage	Selects the LFO Waveform	

LFO Shape		-100...+100	Changes the curvature of the LFO Waveform	p.224
LFO Phase [deg]		-180...+180	Sets the LFO phase difference between the left and right	p.237
LFO Freq [Hz]	LFO [Hz]	0.02...20.00	Sets the speed of the LFO	p.237
LFO Amount [Hz]	EnvA[Hz]	-20.00...+20.00	Sets the amount added to or subtracted from the Frequency when the envelope is at maximum	p.237
Tremolo Depth	Depth	0...100	Sets the initial amount of tremolo	p.237
Tremolo Amount	DepthEnvA	-100...+100	Sets the amount added to or subtracted from the Depth when the envelope is at maximum	p.237
Wet/Dry	←	Dry, 1 : 99... 99 : 1, Wet	Sets the balance between the effect and the dry input	D ^{mod}
Source		Off...Tempo	Selects a modulation source for Wet/Dry	
Amount		-100...+100	Sets the modulation amount for Wet/Dry	

LFO Freq [Hz]

Envelope Amount [Hz]

Tremolo Depth

Tremolo Amount

The graphic below shows an example of tremolo modulation with negative modulation of both "Depth" and "Frequency." At the start of the note, the input is at maximum volume. This slows down the LFO "Frequency" to 1.0Hz, but also modulates the "Depth" to 0—so the tremolo doesn't have any effect.

As the input volume dies down, the "Frequency" speeds up; the "Depth" also increases, making the tremolo effect increasingly audible. When the input volume approaches silence, the "Depth" is at its maximum (100) and "Frequency" is at 8Hz.

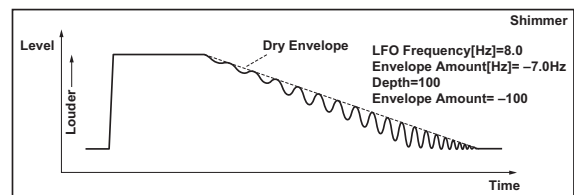

040: St.AutoPan (Stereo Auto Pan)

This is a stereo-in, stereo-out auto-panner. The Phase and Shape parameters lets you create various panning effects, such as making the left and right inputs seem to chase each other around the stereo field.

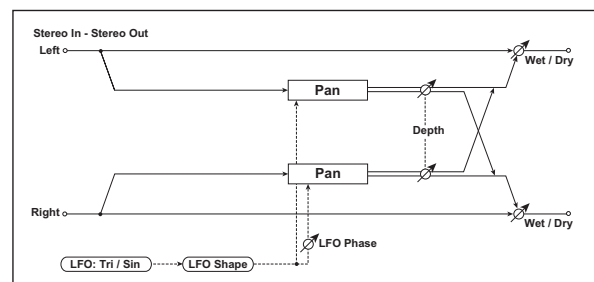

Full parameter	Quick parameter	Value	Explanation	
Depth	←	0...100	Sets the depth of LFO modulation	D ^{mod}

Source		Off...Tempo	Selects the modulation source of the depth of modulation	
Amount		-100...+100	Sets the modulation amount of the depth of modulation	
LFO Waveform		Triangle, Sine	Selects the LFO Waveform	
LFO Shape		-100...+100	Changes the curvature of the LFO Waveform p.238	
LFO Phase [deg]		-180...+180	Sets the LFO phase difference between the left and right p.238	
LFO Freq [Hz]	LFO [Hz]	0.02...20.00	Sets the speed of the LFO p.225	
LFO Source		Off...Tempo	Selects a modulation source for LFO speed	
LFO Amount		-20.00...+20.00	Sets the modulation amount of LFO speed	
LFO BPM/MIDI Sync	LFO MIDI Sync	Off, On	When this is on, the LFO speed is set by BPM, Base Note, and Times, instead of Frequency p.223	
LFO BPM		MIDI, 40.00...300.00	MIDI syncs to the system tempo; 40-300 sets the tempo manually for this individual effect p.223	
LFO Base Note			Selects the type of notes that specify the LFO speed p.223	
LFO Times		x1...x32	Sets the number of notes that specify the LFO speed p.223	
Wet/Dry	←	Dry, 1 : 99... 99 : 1, Wet	Sets the balance between the effect and the dry input	
Source		Off...Tempo	Selects a modulation source for Wet/Dry	
Amount		-100...+100	Sets the modulation amount for Wet/Dry	

LFO Shape

You can change the panning curve by modifying the LFO's "Shape."

LFO Phase [deg]

This determines the phase difference between the left and right LFOs. When you gradually change the value away from 0, the sounds from the left and right channels will seem to chase each other around. If you set the parameter to +180 or -180, the sounds from each channel will cross over each other.

You'll only hear the effect of this parameter if the input is true stereo, with different signals in the left and right channels.

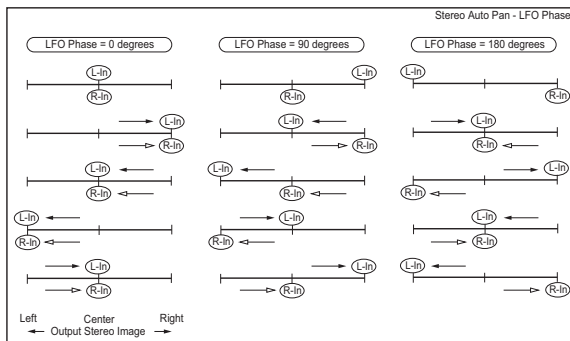

041: St.PhsTrm (Stereo Phaser + Tremolo)

This effect combines a stereo phaser and tremolo, with linked LFOs. Swelling phaser modulation and tremolo effects synchronize with each other, creating a soothing modulation effect particularly suitable for electric piano.

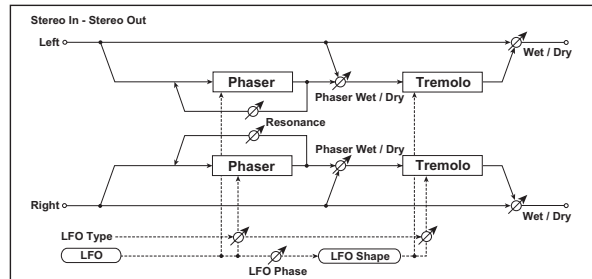

Full parameter	Quick parameter	Value	Explanation	
Phaser Manual	Phs Manual	0...100	Sets the phaser frequency range	
Phaser Resonance	Phs Reso	-100...+100	Sets the phaser resonance amount	
Phaser Depth	Phs Depth	0...100	Sets the phaser modulation depth	
Phaser Source		Off...Tempo	Selects the modulation source for the phaser modulation depth	
Phaser Amount		-100...+100	Sets the modulation amount for the phaser modulation depth	
Phaser Wet/Dry	Pyhs W/D	-Wet, -2 : 98...Dry... 2 : 98, Wet	Sets the balance between the phaser effect and dry sounds p.239	
LFO Phase Type	Type	Phs - Trml, ... Phs LR - Trml LR	Selects the type of the tremolo and phaser LFOs p.239 Phaser - Tremolo, Phaser - Tremolo Spin, Phaser - Tremolo LR, Phaser LR - Tremolo, Phaser LR - Tremolo Spin, Phaser LR - Tremolo LR	
LFO Phase [deg]		-180...+180	Sets the phase difference between the tremolo and phaser LFOs p.239	
LFO Freq [Hz]	LFO [Hz]	0.02...20.00	Sets the speed of the LFO p.225	
LFO Source		Off...Tempo	Selects a modulation source for LFO speed	
LFO Amount		-20.00...+20.00	Sets the LFO speed modulation amount	
LFO BPM/MIDI Sync	LFO MIDI Sync	Off, On	When this is on, the LFO speed is set by BPM, Base Note, and Times, instead of Frequency p.223	
LFO BPM		MIDI, 40.00...300.00	MIDI syncs to the system tempo; 40-300 sets the tempo manually for this individual effect p.223	
LFO Base Note			Selects the type of notes that specify the LFO speed p.223	
LFO Times		x1...x32	Sets the number of notes that specify the LFO speed p.223	
Tremolo Shape		-100...+100	Sets the degree of the tremolo LFO shaping	
Tremolo Depth	Trml Depth	0...100	Sets the tremolo modulation depth	
Tremolo Source		Off...Tempo	Selects the modulation source for the tremolo modulation depth	

Tremolo Amount		-100...+100	Sets the modulation amount of the tremolo modulation depth	
Wet/Dry	←	Dry, 1 : 99... 99 : 1, Wet	Sets the balance between the effect and the dry input p.239	D-mod
Source		Off...Tempo	Selects a modulation source for Wet/Dry	
Amount		-100...+100	Sets the modulation amount for Wet/Dry	

Type

LFO Phase [deg]

Select the type of phaser LFO and tremolo LFO for the "Type" parameter. How the effect sound moves or rotates depends on the type of LFO. Selecting "LFO Phase" enables you to offset the timing of the phaser peak and control a subtle movement and rotation of the sound.

Phaser Wet/Dry

Wet/Dry

"(Phaser) Wet/Dry" sets the balance between the phaser output and the dry sound. "(OUTPUT) Wet/Dry" sets the balance between the final phaser and tremolo output level and the dry sound.

042: St.Ring M (Stereo Ring Modulator)

This effect creates a metallic sound by applying the oscillators to the input signal. Use the LFO or Dynamic Modulation to modulate the oscillator to create a radical modulation. Matching the oscillator frequency with a note number will produce a ring modulation effect in specific key ranges.

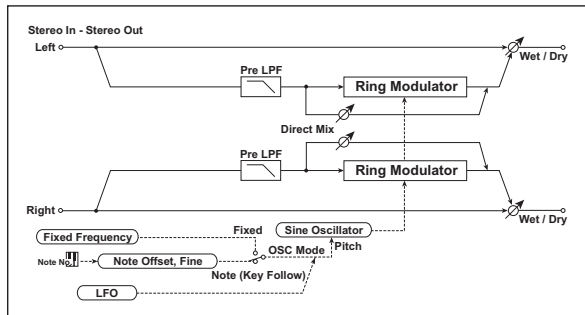

Full parameter	Quick parameter	Value	Explanation	
Pre LPF		0...100	Sets the damping amount of the high range input to the ring modulator p.239	
OSC Mode	OSC	Fixed, Note (Key Follow)	Switching between specifying the oscillator frequency and using a note number p.239	
Fixed Freq [Hz]	Fixed[Hz]	0...12.00k	Sets the oscillator frequency when OSC Mode is set to Fixed p.239	D-mod
Source		Off...Tempo	Selects the modulation source for the oscillator frequency when OSC Mode is set to Fixed	
Amount		-12.00k...+12.00k	Sets the modulation amount of the oscillator frequency when OSC Mode is set to Fixed	

Note Offset	←	-48...+48	Sets the pitch difference from the original note when OSC Mode is set to Note (Key Follow) p.239	
Note Fine	←	-100...+100	Fine-adjusts the oscillator frequency p.239	
Direct Mix	←	0...100	Direct signal (after passing through the pre-low-pass filter) mixed into the ring modulation output	
LFO Freq [Hz]	LFO [Hz]	0.02...20.00	Sets the speed of the LFO p.225	D-mod
Source		Off...Tempo	Selects a modulation source for LFO speed	
Amount		-20.00...+20.00	Sets the modulation amount of LFO speed	
BPM/MIDI Sync	LFO MIDI Sync	Off, On	When this is on, the LFO speed is set by BPM, Base Note, and Times, instead of Frequency p.223	ajuno
BPM		MIDI, 40.00...300.00	MIDI syncs to the system tempo; 40-300 sets the tempo manually for this individual effect p.223	
Base Note			Selects the type of notes that specify the LFO speed p.223	
Times		x1...x32	Sets the number of notes that specify the LFO speed p.223	
LFO Depth	←	0...100	Sets the depth of LFO modulation for the oscillator frequency	D-mod
Source		Off...Tempo	Selects the modulation source of the depth of modulation	
Amount		-100...+100	Sets the modulation amount of the depth of modulation	
Wet/Dry	←	Dry, 1 : 99...99 : 1, Wet	Sets the balance between the effect and the dry input	D-mod
Source		Off...Tempo	Selects a modulation source for Wet/Dry	
Amount		-100...+100	Sets the modulation amount for Wet/Dry	

OSC Mode

This parameter determines whether or not the oscillator frequency follows the note number.

Pre LPF

This parameter enables you to set the damping amount of the high range sound input to the ring modulator. If the input sound contains lots of harmonics, the effect may sound dirty. In this case, cut a certain amount of high range.

Fixed Freq [Hz]

This parameter sets the oscillator frequency when "OSC Mode" is set to Fixed.

Note Offset

Note Fine

These parameters for the oscillator are used when "OSC Mode" is set to Note (Key Follow). The "Note Offset" sets the pitch difference from the original note in semitone steps. The "Note Fine" parameter fine-adjusts the pitch in cent steps. Matching the oscillator frequency with the note number produces a ring modulation effect in the correct key.

043: P4EQ - Xctr (Parametric 4-Band EQ - Exciter)

This effect combines a mono four-band parametric equalizer and an exciter.

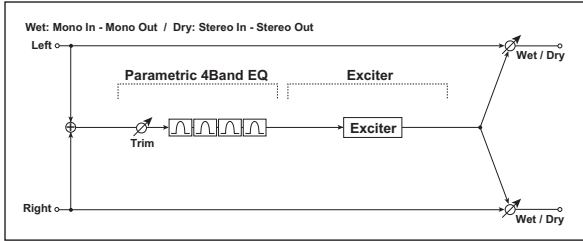

Full parameter	Quick parameter	Value	Explanation	
Parametric 4-Band EQ				
Trim	E Trim	0...100	Sets the parametric EQ input level	
Band1 Cutoff [Hz]	E1 F[Hz]	20...1.00k	Sets the center frequency of Band 1	
Band1 Q	E1 Q	0.5...10.0	Sets the bandwidth of Band 1 p.221	
Band1 Gain [dB]	E1 G[dB]	-18...+18	Sets the gain of Band 1	
Band2 Cutoff [Hz]	E2 F[Hz]	50...5.00k	Sets the center frequency of Band 2	
Band2 Cutoff [Hz]	E2 Q	0.5...10.0	Sets the bandwidth of Band 2 p.221	
Band2 Cutoff [Hz]	E2 G[dB]	-18...+18	Sets the gain of Band 2	
Band3 Cutoff [Hz]	E3 F[Hz]	300...10.00k	Sets the center frequency of Band 3	
Band3 Q	E3 Q	0.5...10.0	Sets the bandwidth of Band 3 p.221	
Band3 Gain [dB]	E3 G[dB]	-18...+18	Sets the gain of Band 3	
Band4 Cutoff [Hz]	E4 F[Hz]	500...20.00k	Sets the center frequency of Band 4	
Band4 Q	E4 Q	0.5...10.0	Sets the bandwidth of Band 4 p.221	
Band4 Gain [dB]	E4 G[dB]	-18...+18	Sets the gain of Band 4	
Exciter				
Exciter Blend	X Blend	-100...+100	Sets the intensity (depth) of the Exciter effect	
Emphasis Freq	F Freq	0...70	Sets the frequency range to be emphasized p.222	
Wet/Dry	←	Dry, 1 : 99... 99 : 1, Wet	Sets the balance between the effect and the dry input	
Source		Off...Tempo	Selects a modulation source for Wet/Dry	
Amount		-100...+100	Sets the modulation amount for Wet/Dry	

044: P4EQ - Wah (Parametric 4-Band EQ - Wah/Auto Wah)

This effect combines a mono four-band parametric equalizer and a wah. You can change the order of the connection.

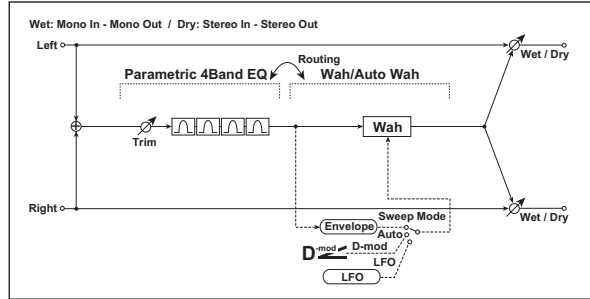

Full parameter	Quick parameter	Value	Explanation	
Parametric 4-Band EQ				
Trim	E Trim	0...100	Sets the parametric EQ input level	
Band1 Cutoff [Hz]	E1 F[Hz]	20...1.00k	Sets the center frequency of Band 1	
Band1 Q	E1 Q	0.5...10.0	Sets the bandwidth of Band 1 p.221	
Band1 Gain [dB]	E1 G[dB]	-18...+18	Sets the gain of Band 1	
Band2 Cutoff [Hz]	E2 F[Hz]	50...5.00k	Sets the center frequency of Band 2	
Band2 Cutoff [Hz]	E2 Q	0.5...10.0	Sets the bandwidth of Band 2 p.221	
Band2 Gain [dB]	E2 G[dB]	-18...+18	Sets the gain of Band 2	
Band3 Cutoff [Hz]	E3 F[Hz]	300...10.00k	Sets the center frequency of Band 3	
Band3 Q	E3 Q	0.5...10.0	Sets the bandwidth of Band 3 p.221	
Band3 Gain [dB]	E3 G[dB]	-18...+18	Sets the gain of Band 3	
Band4 Cutoff [Hz]	E4 F[Hz]	500...20.00k	Sets the center frequency of Band 4	
Band4 Q	E4 Q	0.5...10.0	Sets the bandwidth of Band 4 p.221	
Band4 Gain [dB]	E4 G[dB]	-18...+18	Sets the gain of Band 4	
Wah				
Sweep Mode	W Sweep	Auto, D-mod, LFO	Selects the control from auto-wah, modulation source, and LFO p.223	
Source	Src	Off...Tempo	Selects the modulation source for the wah when Sweep Mode=D-mod 	
LFO Freq [Hz]	W LFO[Hz]	0.02...20.00	Sets the speed of the LFO	
Frequency Bottom	W Freq Btm	0...100	Sets the lower limit of the wah center frequency p.223	
Frequency Top	W Freq Top	0...100	Sets the upper limit of the wah center frequency p.223	
Resonance	W Reso	0...100	Sets the resonance amount	
LPF		Off, On	Switches the wah low pass filter on and off	
[W]Wet/Dry	W W/D	Dry, 1 : 99... 99 : 1, Wet	Sets the wah effect balance 	
[W]Source		Off...Tempo	Selects the Wet/Dry modulation source for the wah	
[W]Amount		-100...+100	Sets the Wet/Dry modulation amount for the wah	
Routing	Route	P4EQ → Wah, Wah → P4EQ	Changes the order of the parametric equalizer and wah connection	

Wet/Dry	←	Dry, 1 : 99... 99 : 1, Wet	Sets the balance between the effect and the dry input	D ^{mod}
Source		Off...Tempo	Selects a modulation source for Wet/Dry	
Amount		-100...+100	Sets the modulation amount for Wet/Dry	

045: P4EQ - Phaser (Parametric 4-Band EQ - Phaser)

This effect combines a mono four-band parametric equalizer and a phaser.

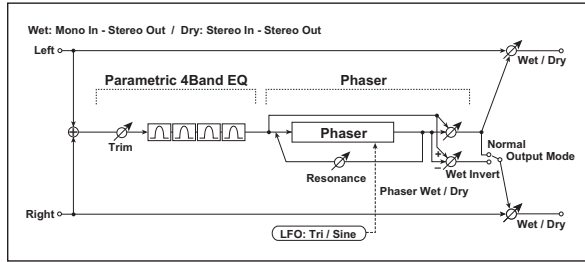

Full parameter	Quick parameter	Value	Explanation	
Parametric 4-Band EQ				
Trim	E Trim	0...100	Sets the parametric EQ input level	
Trim	E1 F[Hz]	20...1.00k	Sets the center frequency of Band 1	
Band1 Cutoff [Hz]	E1 Q	0.5...10.0	Sets the bandwidth of Band 1	p.221
Band1 Gain [dB]	E1 G[dB]	-18...+18	Sets the gain of Band 1	
Band2 Cutoff [Hz]	E2 F[Hz]	50...5.00k	Sets the center frequency of Band 2	
Band2 Gain [dB]	E2 Q	0.5...10.0	Sets the bandwidth of Band 2	p.221
Band2 Q	E2 G[dB]	-18...+18	Sets the gain of Band 2	
Band3 Cutoff [Hz]	E3 F[Hz]	300...10.00k	Sets the center frequency of Band 3	
Band3 Gain [dB]	E3 Q	0.5...10.0	Sets the bandwidth of Band 3	p.221
Band3 Q	E3 G[dB]	-18...+18	Sets the gain of Band 3	
Band4 Cutoff [Hz]	E4 F[Hz]	500...20.00k	Sets the center frequency of Band 4	
Band4 Gain [dB]	E4 Q	0.5...10.0	Sets the bandwidth of Band 4	p.221
Band4 Q	E4 G[dB]	-18...+18	Sets the gain of Band 4	
Phaser				
LFO Freq [Hz]	P LFO [Hz]	0.02...20.00	Sets the speed of the LFO	
LFO Waveform		Triangle, Sine	Selects the LFO Waveform	
Manual	P Manual	0...100	Sets the frequency where the effect is applied	
Depth	P Depth	0...100	Sets the depth of LFO modulation	
Resonance	P Reso	-100...+100	Sets the resonance amount	p.233
Output Mode	P Out	Normal, Wet Invert	Selects the phaser output mode	p.261
[Phs]Wet/Dry	P W/D	-Wet...-1 : 99, Dry, 1 : 99...Wet	Sets the phaser effect balance	p.225, p.233
[Phs]Source		Off...Tempo	Selects the Wet/Dry modulation source for the phaser	
[Phs]Amount		-100...+100	Sets the Wet/Dry modulation amount for the phaser	
Wet/Dry	←	Dry, 1 : 99... 99 : 1, Wet	Sets the balance between the effect and the dry input	D ^{mod}
Source		Off...Tempo	Selects a modulation source for Wet/Dry	

Amount		-100...+100	Sets the modulation amount for Wet/Dry	
--------	--	-------------	--	--

046: Comp - Wah (Compressor - Wah/Auto Wah)

This effect combines a mono compressor and a wah. You can change the order of the connection.

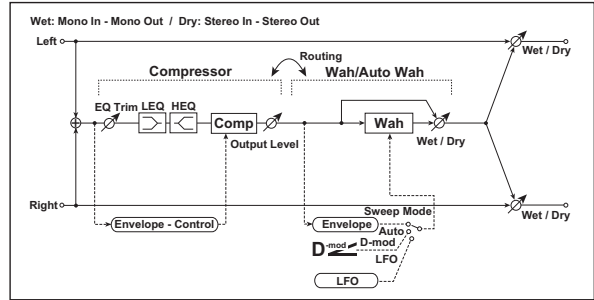

Full parameter	Quick parameter	Value	Explanation	
Compressor				
Sensitivity	C Sens	1...100	Sets the sensitivity	p.217
Attack	C Attack	1...100	Sets the attack level	p.217
Output Level	C Level	0...100	Sets the compressor output level	p.217
Pre EQ Trim		0...100	Sets the EQ input level	
LEQ Gain [dB]		-15...+15	Sets the gain of Low EQ	
HEQ Gain [dB]		-15...+15	Sets the gain of High EQ	
Wah/Auto Wah				
Frequency Bottom	W Freq Btm	0...100	Sets the lower limit of the wah center frequency	p.223
Frequency Top	W Freq Top	0...100	Sets the upper limit of the wah center frequency	p.223
Sweep Mode	W Sweep	Auto, D-mod, LFO	Selects the control from auto-wah, modulation source, and LFO	
Source	Src	Off...Tempo	Selects the modulation source for the wah when Sweep Mode=D-mod	D ^{mod}
LFO Freq [Hz]	W LFO[Hz]	0.02...20.00	Sets the speed of the LFO	
Resonance	W Reso	0...100	Sets the resonance amount	
LPF		Off, On	Switches the wah low pass filter on and off	
[W]Wet/Dry	W W/D	Dry, 1 : 99...99 : 1, Wet	Sets the wah effect balance	D ^{mod}
[W]Source		Off...Tempo	Selects the Wet/Dry modulation source for the wah	
[W]Amount		-100...+100	Sets the Wet/Dry modulation amount for the wah	
Routing	Route	Comp . Wah, Wah → Comp	Switches the order of the compressor and wah	
Wet/Dry	←	Dry, 1 : 99... 99 : 1, Wet	Sets the balance between the effect and the dry input	D ^{mod}
Source		Off...Tempo	Selects a modulation source for Wet/Dry	
Amount		-100...+100	Sets the modulation amount for Wet/Dry	

047: Comp - Amp (Compressor - Amp Simulation)

This effect combines a mono compressor and an amp simulation. You can change the order of the effects.

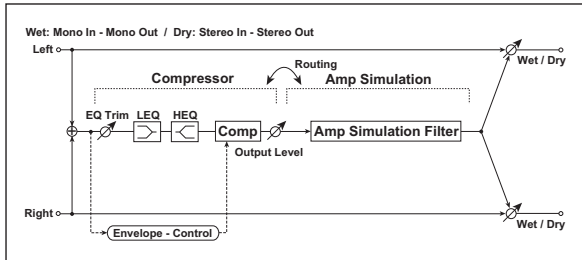

Full parameter	Quick parameter	Value	Explanation	
Compressor				
Sensitivity	C Sens	1...100	Sets the sensitivity p.217	
Attack	C Attack	1...100	Sets the attack level p.217	
Level	C Level	0...100	Sets the compressor output level p.217	
Pre EQ Trim		0...100	Sets the EQ input level	
LEQ Gain [dB]		-15...+15	Sets the gain of Low EQ	
HEQ Gain [dB]		-15...+15	Sets the gain of High EQ	
Amp Simulation				
Amp Type	A Amp Type	SS, EL84, 6L6	Selects the type of guitar amplifier	
Routing	Route	Comp → Amp, Amp → Comp	Switches the order of the compressor and amp simulation	
Wet/Dry	←	Dry, 1 : 99... 99 : 1, Wet	Sets the balance between the effect and the dry input	
Source		Off...Tempo	Selects a modulation source for Wet/Dry	
Amount		-100...+100	Sets the modulation amount for Wet/Dry	

048: Comp - OD (Compressor - Overdrive/Hi.Gain)

This effect combines a mono compressor and an overdrive/high-gain distortion. You can change the order of the effects.

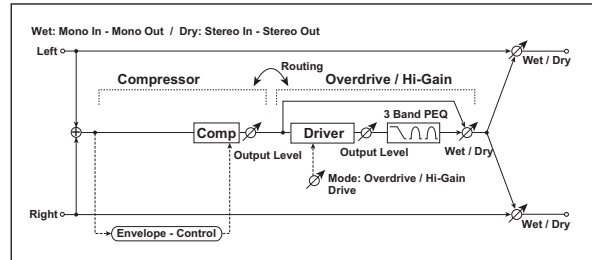

Full parameter	Quick parameter	Value	Explanation	
Compressor				
Sensitivity	C Sens	1...100	Sets the sensitivity p.217	
Attack	C Attack	1...100	Sets the attack level p.217	
Level	C Level	0...100	Sets the compressor output level p.217	
Overdrive/Hi-Gain				
Drive Mode	O Mode	Overdrive, Hi-Gain	Switches between overdrive and high-gain distortion	
Drive	O Drive	1...100	Sets the degree of distortion p.229	
Level	O Out Level	0...50	Sets the overdrive output level p.229	
Source		Off...Tempo	Selects the modulation source for the overdrive output level	
Amount		-50...+50	Sets the modulation amount of the overdrive output level	
Low Cutoff [Hz]		20...1.00k	Sets the center frequency for Low EQ (shelving type)	
Low Gain [dB]	O Low [dB]	-18...+18	Sets the gain of Low EQ	
Mid1 Cutoff [Hz]		300...10.00k	Sets the center frequency for Mid/High EQ 1 (peaking type)	
Mid1 Q		0.5...10.0	Sets the band width of Mid/High EQ 1 p.221	
Mid1 Gain [dB]	O Mid1 [dB]	-18...+18	Sets the gain of Mid/High EQ 1	
Mid2 Cutoff [Hz]		500...20.00k	Sets the center frequency for Mid/High EQ 2 (peaking type)	
Mid2 Q		0.5...10.0	Sets the band width of Mid/High EQ 2 p.221	
Mid2 Gain [dB]	O Mid2 [dB]	-18...+18	Sets the gain of Mid/High EQ 2	
[O]Wet/Dry		Dry, 1 : 99...99 : 1, Wet	Sets the overdrive effect balance	
[O]Source		Off...Tempo	Selects the Wet/Dry modulation source for the overdrive	
[O]Amount		-100...+100	Sets the Wet/Dry modulation amount for the overdrive	
Routing	Route	Comp → OD/HG, OD/HG → Comp	Switches the order of the compressor and overdrive	
Wet/Dry	←	Dry, 1 : 99... 99 : 1, Wet	Sets the balance between the effect and the dry input	
Source		Off...Tempo	Selects a modulation source for Wet/Dry	
Amount		-100...+100	Sets the modulation amount for Wet/Dry	

049: Comp - P4EQ (Compressor - Parametric 4-Band EQ)

This effect combines a mono compressor and a four-band parametric equalizer. You can change the order of the effects.

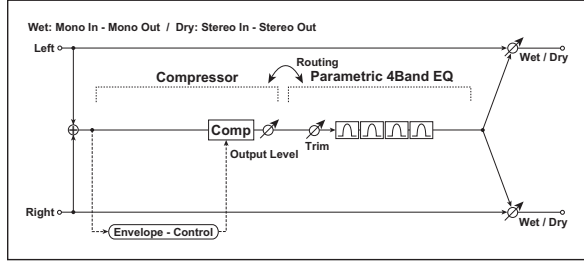

Full parameter	Quick parameter	Value	Explanation
Compressor			
Sensitivity	C Sens	1...100	Sets the sensitivity p.217
Attack	C Attack	1...100	Sets the attack level p.217
Level	C Level	0...100	Sets the compressor output level p.217
Parametric 4-Band EQ			
Trim	E Trim	0...100	Sets the parametric EQ input level
Band1 Cutoff [Hz]	E1 F[Hz]	20...1.00k	Sets the center frequency of Band 1
Band1 Q	E1 Q	0.5...10.0	Sets the bandwidth of Band 1 p.221
Band1 Gain [dB]	E1 G[dB]	-18...+18	Sets the gain of Band 1
Band2 Cutoff [Hz]	E2 F[Hz]	50...5.00k	Sets the center frequency of Band 2
Band2 Q	E2 Q	0.5...10.0	Sets the bandwidth of Band 2 p.221
Band2 Gain [dB]	E2 G[dB]	-18...+18	Sets the gain of Band 2
Band3 Cutoff [Hz]	E3 F[Hz]	300...10.00k	Sets the center frequency of Band 3
Band3 Q	E3 Q	0.5...10.0	Sets the bandwidth of Band 3 p.221
Band3 Gain [dB]	E3 G[dB]	-18...+18	Sets the gain of Band 3
Band4 Cutoff [Hz]	E4 F[Hz]	500...20.00k	Sets the center frequency of Band 4
Band4 Q	E4 Q	0.5...10.0	Sets the bandwidth of Band 4 p.221
Band4 Gain [dB]	E4 G[dB]	-18...+18	Sets the gain of Band 4
Routing	Route	Comp → P4EQ, P4EQ → Comp	Switches the order of the compressor and parametric EQ
Wet/Dry	←	Dry, 1 : 99... 99 : 1, Wet	Sets the balance between the effect and the dry input D^{mod}
Source		Off...Tempo	Selects a modulation source for Wet/Dry
Amount		-100...+100	Sets the modulation amount for Wet/Dry

050: Comp - Phsr (Compressor - Phaser)

This effect combines a mono compressor and a phaser. You can change the order of the effects.

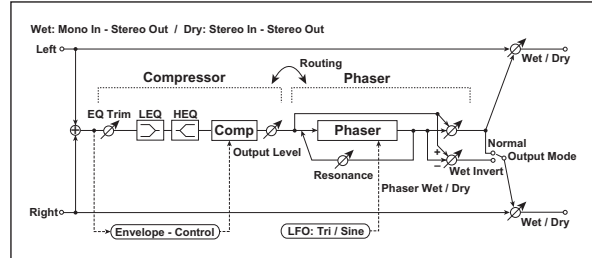

Full parameter	Quick parameter	Value	Explanation
Compressor			
Sensitivity	C Sens	1...100	Sets the sensitivity p.217
Attack	C Attack	1...100	Sets the attack level p.217
Level	C Level	0...100	Sets the compressor output level p.217
Pre EQ Trim		0...100	Sets the EQ input level
LEQ Gain [dB]		-15...+15	Sets the gain of Low EQ
HEQ Gain [dB]		-15...+15	Sets the gain of High EQ
Phaser			
LFO Waveform		Triangle, Sine	Selects the LFO Waveform
LFO Freq [Hz]	P LFO [Hz]	0.02...20.00	Sets the speed of the LFO
Manual	P Manual	0...100	Sets the frequency where the effect is applied
Depth	P Depth	0...100	Sets the depth of LFO modulation
Resonance	P Reso	-100...+100	Sets the resonance amount p.233
Output Mode	P Out	Normal, Wet Invert	Selects the phaser output mode p.260
[Phs] Wet/Dry	P W/D	-Wet... -1 : 99, Dry, 1 : 99...Wet	Sets the phaser effect balance p.225, p.233 D^{mod}
[Phs]Source		Off...Tempo	Selects the Wet/Dry modulation source for the phaser
[Phs]Amount		-100...+100	Sets the Wet/Dry modulation amount for the phaser
Routing	←	Comp → Phaser, Phaser → Comp	Switches the order of the compressor and phaser p.261
Wet/Dry	←	Dry, 1 : 99... 99 : 1, Wet	Sets the balance between the effect and the dry input D^{mod}
Source		Off...Tempo	Selects a modulation source for Wet/Dry
Amount		-100...+100	Sets the modulation amount for Wet/Dry

051: Lmtr - P4EQ (Limiter - Parametric 4-Band EQ)

This effect combines a mono limiter and a four-band parametric equalizer. You can change the order of the effects.

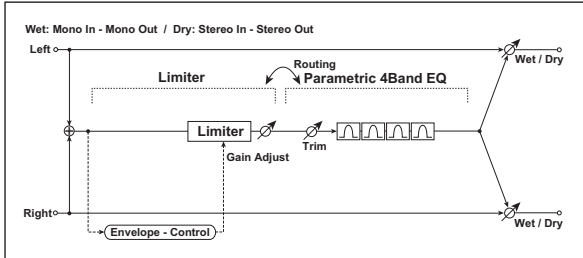

Full parameter	Quick parameter	Value	Explanation	
Limiter				
Ratio	L Ratio	1.0 : 1... 50.0 : 1, Inf : 1	Sets the signal compression ratio p.244	
Threshold [dB]	L Trsh[dB]	-40...0	Sets the level above which the compressor is applied p.244	
Attack	L Attack	1...100	Sets the attack time	
Release	L Release	1...100	Sets the release time	
[Gain Adjust [dB]	L G [dB]	-Inf, -38...+24	Sets the limiter output gain p.244	
Parametric 4-Band EQ				
Trim	E Trim	0...100	Sets the parametric EQ input level	
Band1 Cutoff [Hz]	E1 F[Hz]	20...1.00k	Sets the center frequency of Band 1	
Band1 Q	E1 Q	0.5...10.0	Sets the bandwidth of Band 1 p.221	
Band1 Gain [dB]	E1 G[dB]	-18...+18	Sets the gain of Band 1	
Band2 Cutoff [Hz]	E2 F[Hz]	50...5.00k	Sets the center frequency of Band 2	
Band2 Q	E2 Q	0.5...10.0	Sets the bandwidth of Band 2 p.221	
Band2 Gain [dB]	E2 G[dB]	-18...+18	Sets the gain of Band 2	
Band3 Cutoff [Hz]	E3 F[Hz]	300...10.00k	Sets the center frequency of Band 3	
Band3 Q	E3 Q	0.5...10.0	Sets the bandwidth of Band 3 p.221	
Band3 Gain [dB]	E3 G[dB]	-18...+18	Sets the gain of Band 3	
Band4 Cutoff [Hz]	E4 F[Hz]	500...20.00k	Sets the center frequency of Band 4	
Band4 Q	E4 Q	0.5...10.0	Sets the bandwidth of Band 4 p.221	
Band4 Gain [dB]	E4 G[dB]	-18...+18	Sets the gain of Band 4	
Routing	Route	Lmt → P4EQ, P4EQ → Lmt	Switches the order of the limiter and parametric EQ	
Wet/Dry	←	Dry, 1 : 99... 99 : 1, Wet	Sets the balance between the effect and the dry input	
Source		Off...Tempo	Selects a modulation source for Wet/Dry	
Amount		-100...+100	Sets the modulation amount for Wet/Dry	

Ratio

Threshold [dB]

Gain Adjust [dB]

This parameter sets the signal compression “[L]Ratio.” Compression is applied only when the signal level exceeds the “Threshold” value.

Adjust the output level using the “Gain Adjust” parameter, since compression causes the entire level to be reduced.

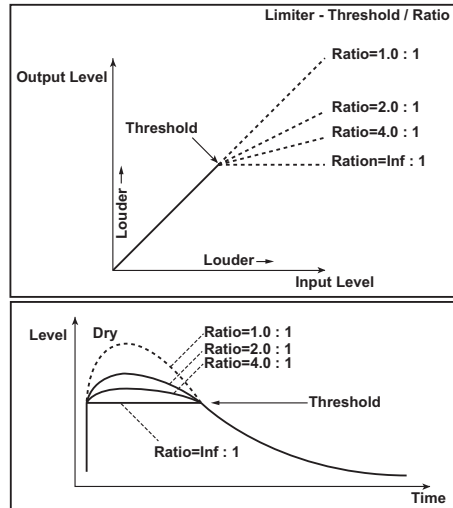

052: Limtr - Phsr

This effect combines a mono limiter and a phaser. You can change the order of the effects.

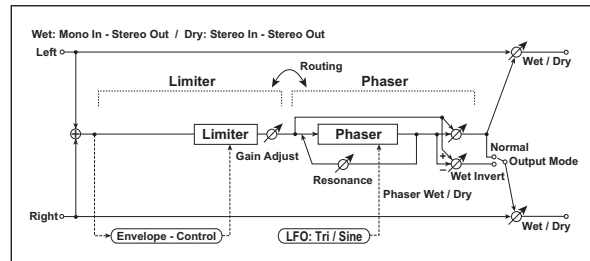

Full parameter	Quick parameter	Value	Explanation	
Limiter				
Ratio	L Ratio	1.0 : 1... 50.0 : 1, Inf : 1	Sets the signal compression ratio p.244	
Threshold [dB]	L Trsh[dB]	-40...0	Sets the level above which the compressor is applied p.244	
Attack	L Attack	1...100	Sets the attack time	
Release	L Release	1...100	Sets the release time	
Gain Adjust [dB]	L G [dB]	-Inf, -38...+24	Sets the limiter output gain p.244	
Phaser				
LFO Freq [Hz]	P LFO [Hz]	0.02...20.00	Sets the speed of the LFO	
LFO Waveform		Triangle, Sine	Selects the LFO Waveform	
Manual	P Manual	0...100	Sets the frequency where the effect is applied	
Depth	P Depth	0...100	Sets the depth of LFO modulation	
Resonance	P Reso	-100...+100	Sets the resonance amount p.233	
Output Mode	P Out	Normal, Wet Invert	Selects the phaser output mode p.260	
[Phs] Wet/Dry	P W/D	-Wet... -1 : 99, Dry, 1 : 99...Wet	Sets the phaser effect balance p.225, p.233	
[Phs] Source		Off...Tempo	Selects the phaser's Wet/Dry modulation source	
[Phs] Amount		-100...+100	Sets the phaser's Wet/Dry modulation amount	
Routing	←	Limiter → Phaser, Phaser → Limiter	Switches the order of the limiter and phaser p.261	

Wet/Dry	←	Dry, 1 : 99... 99 : 1, Wet	Sets the balance between the effect and the dry input	
Source		Off...Tempo	Selects a modulation source for Wet/Dry	
Amount		-100...+100	Sets the modulation amount for Wet/Dry	

053: Xctr - Comp (Exciter - Compressor)

This effect combines a mono exciter and a compressor. You can change the order of the effects.

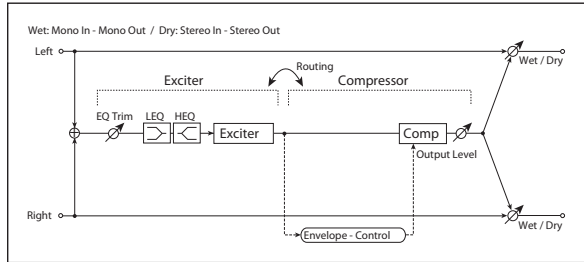

Full parameter	Quick parameter	Value	Explanation	
Exciter				
Blend	X Blend	-100...+100	Sets the intensity (depth) of the Exciter effect p.222	
Emphasis Freq	F Freq	0...70	Sets the frequency range to be emphasized p.222	
Pre EQ Trim		0...100	Sets the EQ input level	
[LEQ Gain [dB]		-15...+15	Sets the gain of Low EQ	
HEQ Gain [dB]		-15...+15	Sets the gain of High EQ	
Compressor				
Sensitivity	C Sens	1...100	Sets the sensitivity p.217	
Attack	C Attack	1...100	Sets the attack level p.217	
Level	C OutLevel	0...100	Sets the compressor output level p.217	
Routing	Route	Xct → Cmp, Cmp → Xct	Switches the order of the exciter and compressor	
Wet/Dry	←	Dry, 1 : 99... 99 : 1, Wet	Sets the balance between the effect and the dry input	
Source		Off...Tempo	Selects a modulation source for Wet/Dry	
Amount		-100...+100	Sets the modulation amount for Wet/Dry	

054: Xctr- Lmtr

This effect combines a mono exciter and a limiter. You can change the order of the effects.

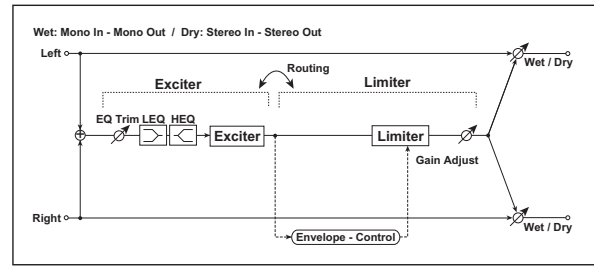

Full parameter	Quick parameter	Value	Explanation	
Exciter				
Blend	X Blend	-100...+100	Sets the intensity (depth) of the Exciter effect p.222	
Emphasis Freq	F Freq	0...70	Sets the frequency range to be emphasized p.222	
Pre EQ Trim		0...100	Sets the EQ input level	
[LEQ Gain [dB]		-15...+15	Sets the gain of Low EQ	
HEQ Gain [dB]		-15...+15	Sets the gain of High EQ	
Limiter				
Ratio	L Ratio	1.0 : 1 ... 50.0 : 1, Inf : 1	Sets the signal compression ratio p.244	
Threshold [dB]	L Trsh[dB]	-40...0	Sets the level above which the compressor is applied p.244	
Attack	L Attack	1...100	Sets the attack time	
Release	L Release	1...100	Sets the release time	
Gain Adjust [dB]	L G [dB]	-Inf, -38...+24	Sets the limiter output gain p.244	
Routing	Route	Xct → Lmt, Lmt → Xct	Switches the order of the exciter and limiter	
Wet/Dry	←	Dry, 1 : 99... 99 : 1, Wet	Sets the balance between the effect and the dry input	
Source		Off...Tempo	Selects a modulation source for Wet/Dry	
Amount		-100...+100	Sets the modulation amount for Wet/Dry	

055: Xctr- Phsr

This effect combines a mono limiter and a phaser.

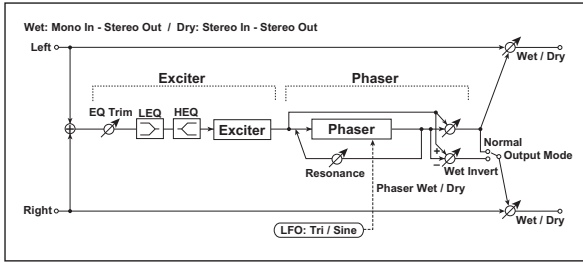

Full parameter	Quick parameter	Value	Explanation	
Exciter				
Blend	X Blend	-100...+100	Sets the intensity (depth) of the Exciter effect p.222	
Emphasis Freq	F Freq	0...70	Sets the frequency range to be emphasized p.222	
Pre EQ Trim		0...100	Sets the EQ input level	
[LEQ Gain [dB]		-15...+15	Sets the gain of Low EQ	
[HEQ Gain [dB]		-15...+15	Sets the gain of High EQ	
Phaser				
LFO Freq [Hz]	P LFO [Hz]	0.02...20.00	Sets the speed of the LFO	
LFO Waveform		Triangle, Sine	Selects the LFO Waveform	
Manual	P Manual	0...100	Sets the frequency where the effect is applied	
Depth	P Depth	0...100	Sets the depth of LFO modulation	
Resonance	P Reso	-100...+100	Sets the resonance amount p.233	
Output Mode	P Out	Normal, Wet Invert	Selects the phaser output mode p.260	
[Phs] Wet/Dry	P W/D	-Wet... -1 : 99, Dry, 1 : 99...Wet	Sets the phaser effect balance p.225, p.233	
[Phs] Source		Off...Tempo	Selects the Wet/Dry modulation source for the phaser	
[Phs] Amount		-100...+100	Sets the Wet/Dry modulation amount for the phaser	
Wet/Dry	←	Dry, 1 : 99... 99 : 1, Wet	Sets the balance between the effect and the dry input	
Source	Src	Off...Tempo	Selects a modulation source for Wet/Dry	
Amount		-100...+100	Sets the modulation amount for Wet/Dry	

056: OD - Amp (Overdrive/Hi.Gain - Amp Simulation)

This effect combines a mono overdrive/high-gain distortion and an amp simulation. You can change the order of the effects.

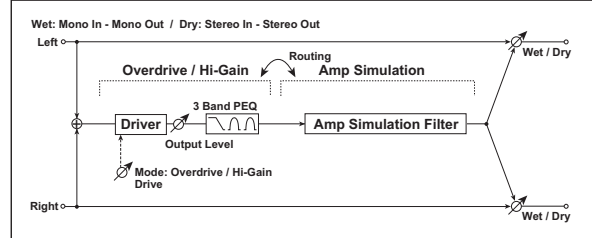

Full parameter	Quick parameter	Value	Explanation	
Overdrive/Hi-Gain				
Drive Mode	O Mode	Overdrive, Hi-Gain	Switches between overdrive and high-gain distortion	
Drive	O Drive	1...100	Sets the degree of distortion p.229	
Level	O Out Level	0...50	Sets the overdrive output level p.229	
Source		Off...Tempo	Selects the modulation source for the overdrive output level	
Amount		-50...+50	Sets the modulation amount of the overdrive output level	
Low Cutoff [Hz]		20...1.00k	Sets the center frequency for Low EQ (shelving type)	
Low Gain [dB]	O Low [dB]	-18...+18	Sets the gain of Low EQ	
Mid1 Cutoff [Hz]		300...10.00k	Sets the center frequency for Mid/High EQ 1 (peaking type)	
Mid1 Q		0.5...10.0	Sets the band width of Mid/High EQ 1 p.221	
Mid1 Gain [dB]	O Mid1 [dB]	-18...+18	Sets the gain of Mid/High EQ 1	
Mid2 Cutoff [Hz]		500...20.00k	Sets the center frequency for Mid/High EQ 2 (peaking type)	
Mid2 Q		0.5...10.0	Sets the band width of Mid/High EQ 2 p.221	
Mid2 Gain [dB]	O Mid2 [dB]	-18...+18	Sets the gain of Mid/High EQ 2	
Amp Simulation				
Amp Type	A Amp Type	SS, EL84, 6L6	Selects the type of guitar amplifie	
Routing		OD → Amp, Amp → OD	Switches the order of the overdrive and amp	
Wet/Dry	←	Dry, 1 : 99... 99 : 1, Wet	Sets the balance between the effect and the dry input	
Source		Off...Tempo	Selects a modulation source for Wet/Dry	
Amount		-100...+100	Sets the modulation amount for Wet/Dry	

057: OD - Phsr (Overdrive/Hi.Gain - Phaser)

This effect combines a mono overdrive/high-gain distortion and a phaser. You can change the order of the effects.

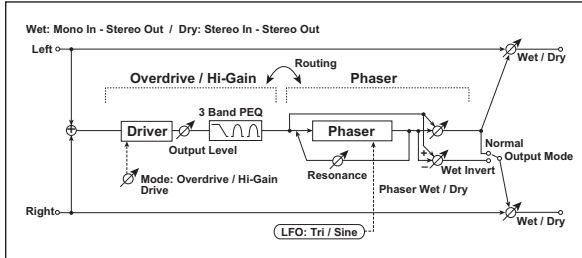

Full parameter	Quick parameter	Value	Explanation
Overdrive/Hi-Gain			
Drive Mode	O Mode	Overdrive, Hi-Gain	Switches between overdrive and high-gain distortion
Drive	O Drive	1...100	Sets the degree of distortion p.229
Level	O Out Level	0...50	Sets the overdrive output level p.229
Source		Off...Tempo	Selects the modulation source for the overdrive output level
Amount		-50...+50	Sets the modulation amount of the overdrive output level
Low Cutoff [Hz]		20...1.00k	Sets the center frequency for Low EQ (shelving type)
Low Gain [dB]	O Low [dB]	-18...+18	Sets the gain of Low EQ
Mid1 Cutoff [Hz]		300...10.00k	Sets the center frequency for Mid/High EQ 1 (peaking type)
Mid1 Q		0.5...10.0	Sets the band width of Mid/High EQ 1 p.221
Mid1 Gain [dB]	O Mid1 [dB]	-18...+18	Sets the gain of Mid/High EQ 1
Mid2 Cutoff [Hz]		500...20.00k	Sets the center frequency for Mid/High EQ 2 (peaking type)
Mid2 Q		0.5...10.0	Sets the band width of Mid/High EQ 2 p.221
Mid2 Gain [dB]	O Mid2 [dB]	-18...+18	Sets the gain of Mid/High EQ 2
Phaser			
LFO Freq [Hz]	P LFO [Hz]	0.02...20.00	Sets the speed of the LFO
LFO Waveform		Triangle, Sine	Selects the LFO Waveform
Manual	P Manual	0...100	Sets the frequency where the effect is applied
Depth	P Depth	0...100	Sets the depth of LFO modulation
Resonance	P Reso	-100...+100	Sets the resonance amount p.233
Output Mode	P Out	Normal, Wet Invert	Selects the phaser output mode p.261
[Phs] Wet/Dry	P W/D	-Wet...-1 : 99, Dry, 1 : 99...Wet	Sets the phaser effect balance p.225, p.233
[Phs] Source		Off...Tempo	Selects the Wet/Dry modulation source for the phaser
[Phs] Amount		-100...+100	Sets the Wet/Dry modulation amount for the phaser

Routing	←	OD/HG → Phaser, Phaser → OD/HG	Switches the order of the overdrive and phaser p.261
Wet/Dry	←	Dry, 1 : 99... 99 : 1, Wet	Sets the balance between the effect and the dry input
Source		Off...Tempo	Selects a modulation source for Wet/Dry
Amount		-100...+100	Sets the modulation amount for Wet/Dry

058: Wah - Amp (Wah - Amp Simulation)

This effect combines a mono wah and an amp simulation. You can change the order of the effects.

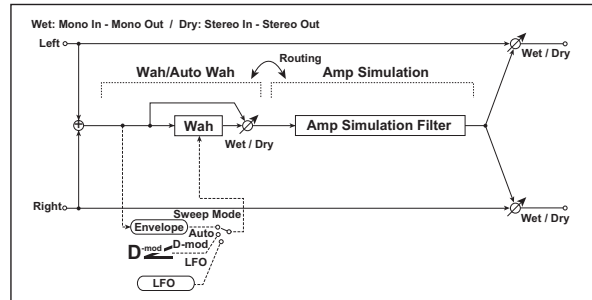

Full parameter	Quick parameter	Value	Explanation
Wah/Auto Wah			
Frequency Bottom	W Freq Btm	0...100	Sets the lower limit of the wah center frequency p.223
Frequency Top	W Freq Top	0...100	Sets the upper limit of the wah center frequency p.223
Sweep Mode	W Sweep	Auto, D-mod, LFO	Selects the control from auto-wah, modulation source, and LFO p.223
Source	Src	Off...Tempo	Selects the modulation source for the wah when Sweep Mode=D-mod
LFO Freq [Hz]	W LFO [Hz]	0.02...20.00	Sets the speed of the LFO
Resonance	W Reso	0...100	Sets the resonance amount
LPF		Off, On	Switches the wah low pass filter on and off
[W]Wet/Dry	W W/D	Dry, 1 : 99... 99 : 1, Wet	Sets the wah effect balance
[W]Source		Off...Tempo	Selects the Wet/Dry modulation source for the wah
[W]Amount		-100...+100	Sets the Wet/Dry modulation amount for the wah
Amp Simulation			
Amp Type	A Amp Type	SS, EL84, 6L6	Selects the type of guitar amplifier
Routing	Route	Wah → Amp, Amp → Wah	Switches the order of the wah and amp simulation
Wet/Dry	←	Dry, 1 : 99... 99 : 1, Wet	Sets the balance between the effect and the dry input
Source		Off...Tempo	Selects a modulation source for Wet/Dry
Amount		-100...+100	Sets the modulation amount for Wet/Dry

059: Deci - Amp (Decimator - Amp Simulation)

This effect combines a mono decimator and an amp simulation. You can change the order of the effects.

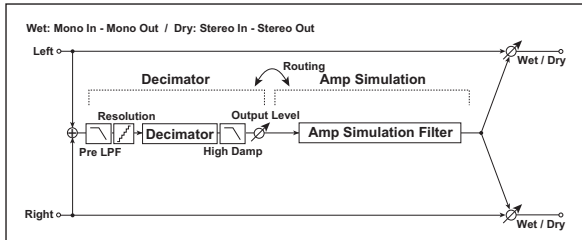

Full parameter	Quick parameter	Value	Explanation
Decimator			
Pre LPF	D Pre LPF	Off, On	Turn the harmonic noise caused by lowered sampling on and off p.227
High Damp [%]		0...100	Sets the ratio of high-range damping
Sampling Freq [Hz]	D Fs[Hz]	1.00k...48.00 k	Sets the sampling frequency
Resolution	D Bit Reso	4...24	Sets the data bit length p.227
Level	D OutLevel	0...100	Sets the decimator output level p.227
Amp Simulation			
Amp Type	A Amp Type	SS, EL84, 6L6	Selects the type of guitar amplifier
Routing	Route	Dec → Amp, Amp → Dec	Switches the order of the decimator and amp simulation
Wet/Dry	←	Dry, 1 : 99... 99 : 1, Wet	Sets the balance between the effect and the dry input
Source		Off...Tempo	Selects a modulation source for Wet/Dry
Amount		-100...+100	Sets the modulation amount for Wet/Dry

060: Deci - Comp (Decimator - Compressor)

This effect combines a mono decimator and a compressor. You can change the order of the effects.

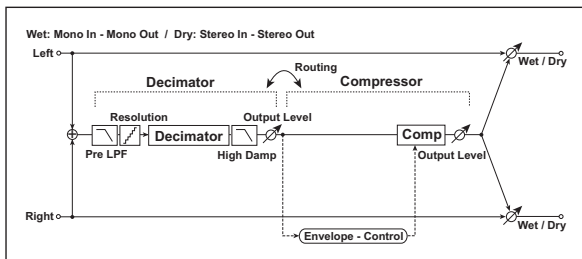

Full parameter	Quick parameter	Value	Explanation
Decimator			
Pre LPF	P Pre LPF	Off, On	Turn the harmonic noise caused by lowered sampling on and off p.227
High Damp [%]		0...100	Sets the ratio of high-range damping
Sampling Freq [Hz]	D Fs[Hz]	1.00k...48.00 k	Sets the sampling frequency
Resolution	D Bit Reso	4...24	Sets the data bit length p.227

Level	D OutLevel	0...100	Sets the decimator output level p.227
Compressor			
Sensitivity	C Sens	1...100	Sets the sensitivity p.217
Attack	C Attack	1...100	Sets the attack level p.217
Level	C Level	0...100	Sets the compressor output level p.217
Routing	Route	Dec → Cmp, Cmp → Dec	Switches the order of the decimator and compressor
Wet/Dry	←	Dry, 1 : 99... 99 : 1, Wet	Sets the balance between the effect and the dry input
Source		Off...Tempo	Selects a modulation source for Wet/Dry
Amount		-100...+100	Sets the modulation amount for Wet/Dry

061: Amp - Trml (Amp Simulation- Tremolo)

This effect combines a mono amp simulation and a tremolo.

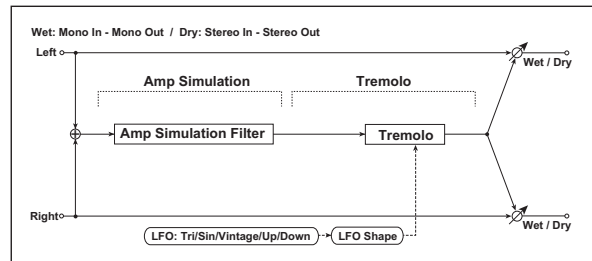

Full parameter	Quick parameter	Value	Explanation
Amp Simulation			
Amp Type	A Amp Type	SS, EL84, 6L6	Selects the type of guitar amplifier
Tremolo			
LFO Waveform	T LFO	Triangle, Sine, Vintage, Up, Down	Selects the LFO Waveform p.236
LFO Shape		-100...+100	Changes the curvature of the LFO Waveform p.224
LFO Freq [Hz]	T LFO[Hz]	0.02...20.00	Sets the speed of the LFO
Depth	T Depth	0...100	Sets the depth of LFO modulation
Wet/Dry	←	Dry, 1 : 99... 99 : 1, Wet	Sets the balance between the effect and the dry input
Source		Off...Tempo	Selects a modulation source for Wet/Dry
Amount		-100...+100	Sets the modulation amount for Wet/Dry

062: Organ Vib/Chorus (Organ Vibrato/Chorus)

This effect simulates the chorus and vibrato circuitry of a vintage organ. The modulation speed and depth can be customized.

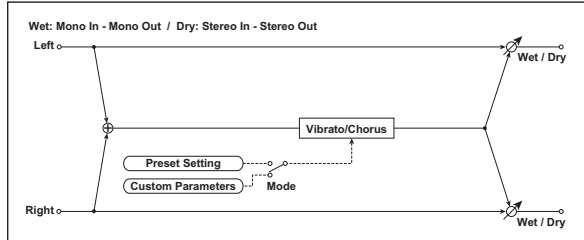

Full parameter	Quick parameter	Value	Explanation	
Input Trim		0...100	Sets the input level	
Control Mode	Mode	Preset, Custom	Selects either preset or custom settings p.249	
Preset Type	←	V1, C1, V2, C2, V3, C3	Selects the effect type when Mode=Preset V1/V2/V3 are variations of vibrato, and C1/C2/C3 are variations of chorus p.249	D ^{mod}
Source		Off...Tempo	Selects the modulation source that will change the effect type	
Amount		-5...+5	Sets the modulation amount for changing the effect type p.249	
Custom Mix		Vibrato, 1:99...99:1, Chorus	Sets the mix level of the direct sound when Mode=Preset p.249	D ^{mod}
Source		Off...Tempo	Selects the modulation source that will control the mix level of the direct sound	
Amount		-100...+100	Sets the modulation amount for controlling the mix level of the direct sound	
Custom Depth		0...100	Sets the vibrato depth p.249	D ^{mod}
Source		Off...Tempo	Selects the modulation source that will control vibrato depth	
Amount		-100...+100	Sets the modulation amount for controlling the vibrato depth	
Custom Speed		0.02...20.00	Sets the vibrato speed p.249	D ^{mod}
Source		Off...Tempo	Selects the modulation source for controlling the vibrato speed	
Amount		-20.00...+20.00	Sets the modulation amount for controlling the vibrato speed	
Wet/Dry	←	Dry, 1 : 99... 99 : 1, Wet	Sets the balance between the effect and the dry input	D ^{mod}
Source		Off...Tempo	Selects a modulation source for Wet/Dry	
Amount		-100...+100	Sets the modulation amount for Wet/Dry	

Control Mode

Preset Type

Custom Mix

Custom Depth

Custom Speed

If Control Mode=Preset, you can use Preset Type to select the effect. In this case, the Custom Mix/Depth/Speed settings are ignored. If Control Mode=Custom, the Custom Mix/Depth/Speed settings are valid, and the Preset Type setting is ignored.

Amount

If Preset Type=V1 and Source=JS+Y, you can set this to +5 and move JS +Y to control the effect in the order of V1→C1→V2→C2→V3→C3.

063: Rotary SP (Rotary Speaker)

This effect simulates a rotary speaker, and obtains a more realistic sound by simulating the rotor in the low range and the horn in the high range separately. The effect also simulates the stereo microphone settings.

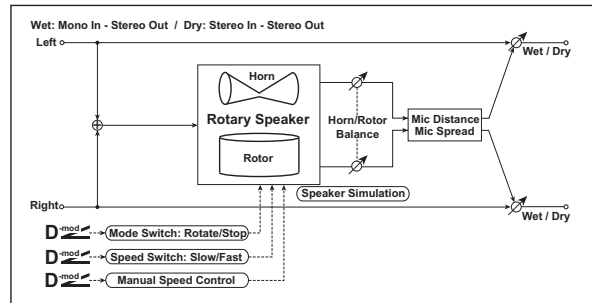

Full parameter	Quick parameter	Value	Explanation	
Mode	Mode SW	Rotate, Stop	Switches between speaker rotation and stop	D ^{mod}
Source		Off...Tempo	Selects a modulation source for Rotate/Stop	
Switch Mode		Toggle, Moment	Sets the switch mode for Rotate/Stop modulation p.250	
Speed Switch	Speed SW	Slow, Fast	Switches the speaker rotation speed between slow and fast p.250	D ^{mod}
Source		Off...Tempo	Selects a modulation source for Slow/Fast	
Switch Mode		Toggle, Moment	Sets the switch mode for Slow/Fast modulation p.250	
H/R Balance		Rotor, 1...99, Horn	Sets the level balance between the high-frequency horn and low-frequency rotor	
Manual Speed		Off...Tempo	Sets a modulation source for direct control of rotation speed p.250	D ^{mod}
Horn Acceleration		0...100	How quickly the horn rotation speed in the high range is switched p.250	
Horn Ratio		Stop, 0.50...2.00	Adjusts the (high-range side) horn rotation speed. Standard value is 1.00. Selecting "Stop" will stop the rotation	
Rotor Acceleration		0...100	Determines how quickly the rotor rotation speed in the low range is switched p.250	

Rotor Ratio		Stop, 0.50...2.00	Adjusts the (low-frequency) rotor speed. Standard value is 1.00. Selecting "Stop" will stop the rotation	
Mic Distance		0...100	Sets the distance between the microphone and rotary speaker p.250	
Mic Spread		0...100	Sets the angle of left and right microphones p.250	
Wet/Dry	←	Dry, 1 : 99... 99 : 1, Wet	Sets the balance between the effect and the dry input	
Source		Off...Tempo	Selects a modulation source for Wet/Dry	
Amount		-100...+100	Sets the modulation amount for Wet/Dry	

Switch Mode

This parameter sets how the modulation source switches between rotation and stop. When "Switch Mode" = **Toggle**, the speaker rotates or stops alternately each time you press the pedal or move the joystick. Via MIDI, rotation will switch between start and stop each time the modulation amount exceeds 64. When "Switch Mode" = **Moment**, the speaker rotates by default, and stops only when you press the pedal or move the joystick. Via MIDI, modulation values above 64 make the speaker rotate, and values below 64 make it stop.

Speed Switch

This parameter controls how the rotation speed (slow and fast) is switched via the modulation source. When "Switch Mode" = **Toggle**, the speed will switch between slow and fast each time you press the pedal or move the joystick. Via MIDI, the speed will switch each time the modulation amount exceeds 64. When "Switch Mode" = **Moment**, the speed is usually slow. It becomes fast only when you press the pedal or move the joystick. Via MIDI, modulation values above 64 set the speed to **Fast**, and values below 64 set it to **Slow**.

Manual Speed

If you wish to control the rotation speed manually, instead of switching between Slow and Fast, select a modulation source in the "Manual Speed" parameter. If you don't want to use manual control, set this to **Off**.

Horn Acceleration

Rotor Acceleration

On a real rotary speaker, the rotation speed accelerates or decelerates gradually after you switch the speed. The "Horn" and "Rotor Acceleration" parameters set the transition times between fast and slow speeds.

Mic Distance

Mic Spread

This is a simulation of stereo microphone settings.

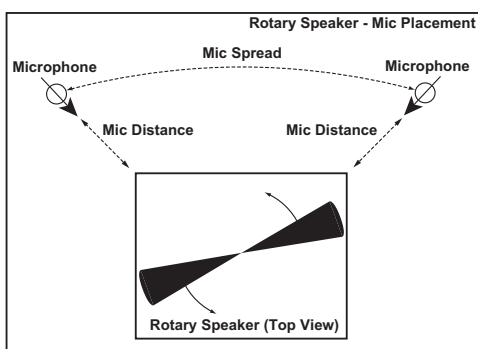

Effects 064–120 can be selected only for the master effect. The master effect does not output a Dry (direct) sound; only the Wet (effect) sound is output, and then mixed with the Dry (direct) sound in the L/R bus.

The parameter names and effect block diagrams are shown in the same way as for the other effects that can also be used as an insert effect, but please note the following points.

- "Wet/Dry" parameter: This controls the level of the Wet (effect) sound. The Dry (direct) sound is not output.
- The output for the Dry (direct) sound is not shown in the effect block diagram.

("In/Out" on page 211)

064: St.Chorus (Stereo Chorus)

This effect adds thickness and warmth to the sound by modulating the delay time of the input signal. You can add spread to the sound by offsetting the phase of the left and right LFOs from each other.

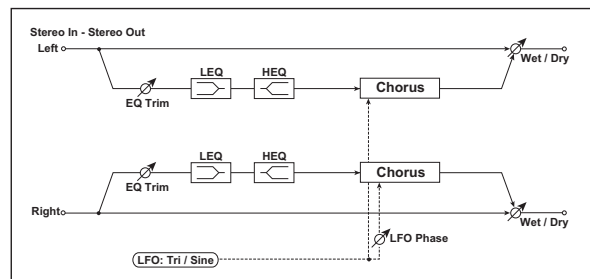

Full parameter	Quick parameter	Value	Explanation	
Pre EQ Trim	PreEQ Trim	0...100	Sets the EQ input level	
Pre LEQ Fc		Low, Mid-Low	Selects the cutoff frequency (low or mid-low) of the low-range equalizer	
LEQ Gain [dB]	LEQ [dB]	-15.0...+15.0	Sets the gain of the Low EQ	
Pre HEQ Fc		High, Mid-High	Selects the cutoff frequency (high or mid-high) of the high-range equalizer	
HEQ Gain [dB]	HEQ [dB]	-15.0...+15.0	Sets the gain of the High EQ	
LFO Waveform		Triangle, Sine	Selects the LFO Waveform	
Phase [deg]		-180...+180	Sets the LFO phase difference between the left and right p.225	
LFO Freq [Hz]	LFO [Hz]	0.02...20.00	Sets the speed of the LFO p.225	
Source		Off...Tempo	Selects a modulation source for LFO speed	
Amount		-20.00...+20.00	Sets the modulation amount of LFO speed	
BPM/MIDI Sync	LFO MIDI Sync	Off, On	When this is on, the LFO speed is set by BPM, Base Note, and Times, instead of Frequency p.223	
BPM		MIDI, 40.00...300.00	MIDI syncs to the system tempo; 40–300 sets the tempo manually for this individual effect p.223	
Base Note			Selects the type of notes that specify the LFO speed p.223	
Times		x1...x32	Sets the number of notes that specify the LFO speed p.223	

L Pre Delay [ms]	L Dly[ms]	0.0...50.0	Sets the delay time for the left channel p.251	
R Pre Delay [ms]	R Dly[ms]	0.0...50.0	Sets the delay time for the right channel p.251	
Depth	←	0...100	Sets the depth of LFO modulation	D ^{mod}
Source		Off...Tempo	Selects the modulation source for the LFO modulation depth	
Amount		-100...+100	Sets the modulation amount of the LFO modulation depth	
Wet/Dry	←	-Wet... -1 : 99, Dry, 1 : 99...Wet	Sets the balance between the effect and the dry input p.225	D ^{mod}
Source		Off...Tempo	Selects a modulation source for Wet/Dry	
Amount		-100...+100	Sets the modulation amount for Wet/Dry	

L Pre Delay [ms]

R Pre Delay [ms]

Setting the left and right delay time individually allows you to control the stereo image.

065: VtgChorus (Vintage Chorus)

This models a famous chorus unit that was built into a guitar amp. Although it does not provide a chorus and vibrato select switch, you can use the “Wet/Dry” and “Bus” settings to produce their effect. The “Speed,” “Depth,” and “Manual” parameters allow an even wider range of sounds than the original unit.

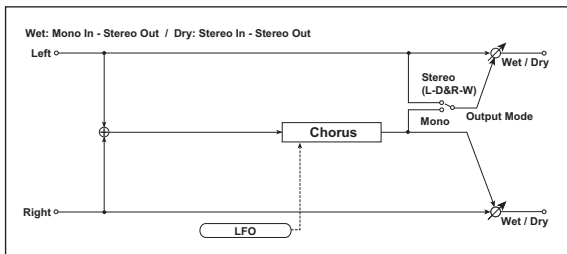

Full parameter	Quick parameter	Value	Explanation	
Speed [Hz]	←	0.10...10.0	Sets the speed of LFO	
Depth	←	0...100	Sets the modulation depth	
Manual	←	1...100	Sets the sweep frequency	
Output Mode	Out	0, 1	Sets the output mode 0: Mono 1: ST (L-D&R-W)	
Wet/Dry	←	Dry, 1:99 ... 99:1, Wet	Sets the balance between the effect and the dry input	D ^{mod}
Source		Off...Tempo	Selects a modulation source for Wet/Dry	
Amount		-100 ... +100	Sets the modulation amount for Wet/Dry	

Wet/Dry

Output Mode

For the master effects, “Wet/Dry” adjusts the output level of the effect sound.

When “Output Mode” is Mono, L and R will output the same vibrato effect. Normally, you’ll produce a chorus effect by adjusting the return level to mix the processed sound with the direct sound. If you turn “Bus” Off and adjust the settings so that none of the direct sound is mixed in, a vibrato effect will be produced.

If “Output Mode” is ST (L-D&R-W), the direct sound will be panned to L, and the effect sound will be panned to R for output. Normally, you’ll mix the direct sound and effect sound by adjusting the return level, applying chorus only to the R channel, and producing a stereo effect that’s spread to the left and right. If you turn “Bus” Off, pan the direct sound and effect sound to the left and right, and output them from stereo speakers, the effect sound and direct sound will be panned in stereo, producing a clear and spacious chorus effect.

066: BlkChorus (Black Chorus)

This models a Danish-made stereo chorus + pitch modulator & flanger. Although this effect was originally intended for guitar, it was also used by numerous keyboard players. Used with electric piano, it produces a distinctive tone.

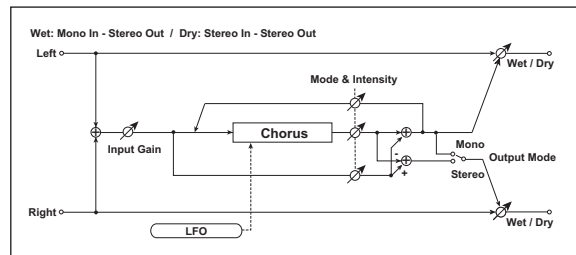

Full parameter	Quick parameter	Value	Explanation	
Speed [Hz]	←	0.10...10.0	Sets the LFO speed	
Intensity	←	1...100	Sets the intensity of LFO modulation	
Mode	←	0, 1, 2	Select a mode 0: Chorus 1: Pitch Modulation 2: Flanger	
Width	←	0...2	Sets the LFO modulation depth	
Input Gain	←	1...1000	Sets the input gain	
Output Mode	Out Mode	0, 1	Select a output mode 0: Mono 1: Stereo	
Wet/Dry	←	Dry, 1:99 ... 99:1, Wet	Sets the balance between the effect and the dry input	D ^{mod}
Source		Off...Tempo	Selects a modulation source for Wet/Dry	
Amount		-100 ... +100	Sets the modulation amount for Wet/Dry	

Mode

Intensity

Increasing the “Intensity” value will strengthen the modulation effect. This controls the effect, direct, and feedback values. The values that are controlled will depend on the “Mode” setting.

067: St.HrmCho (Stereo Harmonic Chorus)

This effect applies chorus only to the higher frequencies. This can be used to apply a chorus effect to a bass sound without making the sound thinner. You can also use this chorus block with feedback as a flanger.

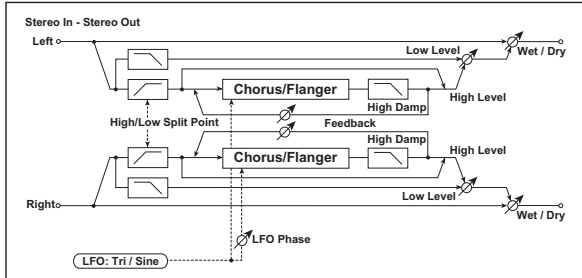

Full parameter	Quick parameter	Value	Explanation	
Pre Delay [ms]	Delay[ms]	0.0...50.0	Sets the delay time from the original sound	
Feedback	←	-100...+100	Sets the feed back amount of the chorus block p.252	
High Damp [%]	←	0...100	Sets the high range damping amount of the chorus block	
High/Low Split	H/L Split	1...100	Sets the frequency split point between the low and high range p.252	
Low Level	←	0...100	Sets the low range output level	
High Level	←	0...100	Sets the high range (chorus) output level	
LFO Waveform		Triangle, Sine	Selects the LFO Waveform	
Phase [deg]		-180...+180	Sets the LFO phase difference between the left and right p.225	
LFO Freq [Hz]	LFO [Hz]	0.02...20.00	Sets the speed of the LFO p.225	
Source		Off...Tempo	Selects a modulation source for LFO speed	
Amount		-20.00...+20.00	Sets the modulation amount of LFO speed	
BPM/MIDI Sync	LFO MIDI Sync	Off, On	When this is on, the LFO speed is set by BPM, Base Note, and Times, instead of Frequency p.223	
BPM		MIDI, 40.00...300.00	MIDI syncs to the system tempo; 40-300 sets the tempo manually for this individual effect p.223	
Base Note			Selects the type of notes that specify the LFO speed p.223	
Times		x1...x32	Sets the number of notes that specify the LFO speed p.223	
Depth		0...100	Sets the depth of LFO modulation	
Source		Off...Tempo	Selects the modulation source of the LFO modulation depth	
Amount		-100...+100	Sets the modulation amount of the LFO modulation depth	
Wet/Dry	←	Dry, 1 : 99... 99 : 1, Wet	Sets the balance between the effect and the dry input	
Source		Off...Tempo	Selects a modulation source for Wet/Dry	
Amount		-100...+100	Sets the modulation amount for Wet/Dry	

High/Low Split

This parameter sets the frequency that splits the high and low range. Only the high range will be sent to the chorus block.

Feedback

Sets the feedback amount of the chorus block. Increasing the feedback will allow you to use the effect as a flanger.

068: St.Bi Mod (Stereo Biphase Modulation)

This stereo chorus effect adds two different LFOs together. You can set the Frequency and Depth parameters for each LFO individually. Depending on the setting of these LFOs, very complex waveforms will create an analog-type, unstable modulated sound.

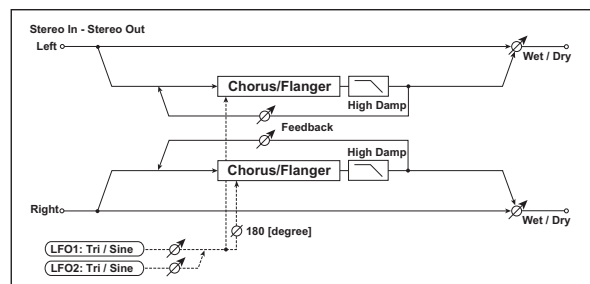

Full parameter	Quick parameter	Value	Explanation	
LFO1 Waveform		Triangle, Sine	Selects LFO1 waveform	
LFO1 Freq [Hz]	LFO1[Hz]	0.02...30.00	Sets the LFO1 speed	
Source		Off...Tempo	Selects the modulation source of LFO1&2 speed	
Amount		-30.00...+30.00	Sets the modulation amount of LFO1 speed	
Depth1	←	0...100	Sets the depth of LFO1 modulation	
Source		Off...Tempo	Selects the modulation source of LFO1&2 modulation depth	
Amount		-100...+100	Sets the modulation amount of LFO1 modulation depth	
LFO2 Waveform		Triangle, Sine	Selects LFO2 waveform	
LFO2 Freq [Hz]	LFO2[Hz]	0.02...30.00	Sets the LFO2 speed	
Amount		-30.00...+30.00	Sets the modulation amount of LFO2 speed	
Depth2	←	0...100	Sets the depth of LFO2 modulation	
Amount		-100...+100	Sets the modulation amount of LFO2 modulation depth	
Phase Sw		0 deg, 180 deg	Switches the LFO phase difference between left and right	
L Pre Delay [ms]	L Dly[ms]	0.0...50.0	Sets the delay time for the left channel p.251	
R Pre Delay [ms]	R Dly[ms]	0.0...50.0	Sets the delay time for the right channel p.251	
Feedback		-100...+100	Sets the feedback amount p.252	
High Damp [%]		0...100	Sets the damping amount in the high range	

Wet/Dry	←	-Wet... -1 : 99, Dry, 1 : 99...Wet	Sets the balance between the effect and the dry input p.225	D ^{mod}
Source		Off...Tempo	Selects a modulation source for Wet/Dry	
Amount		-100...+100	Sets the modulation amount for Wet/Dry	

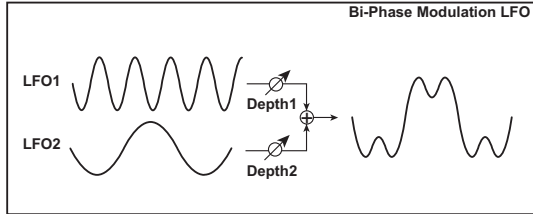

069: Mtap Cho (Multitap Chorus/Delay)

This effect has four chorus blocks with a different LFO phase. You can create a complex stereo image by setting each block's delay time, depth, output level, and pan individually. You can also fix some of the chorus blocks to combine the chorus and delay effects.

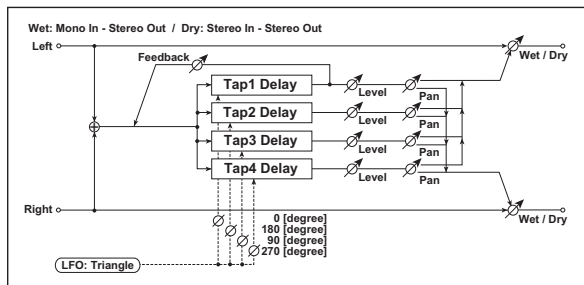

Full parameter	Quick parameter	Value	Explanation	
Tap1 Feedback		-100...+100	Sets the Tap1 feedback amount	D ^{mod}
Source		Off...Tempo	Selects the modulation source of Tap1 feedback amount and effect balance	
Amount		-100...+100	Sets the Tap1 feedback amount and modulation amount	
LFO Freq [Hz]	LFO [Hz]	0.02...13.00	Sets the speed of the LFO	
Tap1 Delay [ms]	Tap1 [ms]	0...1000	Sets the Tap1 (LFO phase=0 degrees) delay time	
Depth	Tap1 Depth	0...30	Sets the Tap1 chorus depth	
Level	Tap1 Level	0...30	Sets the Tap1 output level	
Pan		L6...L1, C, R1...R6	Sets the Tap1 stereo image	
Tap2 Delay [ms]	Tap2 [ms]	0...1000	Sets the Tap2 (LFO phase=180 degrees) delay time	
Depth	Tap2 Depth	0...30	Sets the Tap2 chorus depth	
Level	Tap2 Level	0...30	Sets the Tap2 output level	
Pan		L6...L1, C, R1...R6	Sets the Tap2 stereo image	
Tap3 Delay [ms]	Tap3 [ms]	0...1000	Sets the Tap3 (LFO phase=90 degrees) delay time	
Depth	Tap3 Depth	0...30	Sets the Tap3 chorus depth	
Level	Tap3 Level	0...30	Sets the Tap3 output level	

Pan		L6...L1, C, R1...R6	Sets the Tap3 stereo image	
Tap4 Delay [ms]	Tap4 [ms]	0...1000	Sets the Tap4 (LFO phase=270 degrees) delay time	
Depth	Tap4 Depth	0...30	Sets the Tap4 chorus depth	
Level	Tap4 Level	0...30	Sets the Tap4 output level	
Pan		L6...L1, C, R1...R6	Sets the Tap4 stereo image	
Wet/Dry	←	Dry, 1 : 99... 99 : 1, Wet	Sets the balance between the effect and the dry input	D ^{mod}
Source		Off...Tempo	Selects a modulation source for Wet/Dry	
Amount		-100...+100	Sets the modulation amount for Wet/Dry	

070: Ensemble

This Ensemble effect has three chorus blocks that use LFO to create subtle shimmering, and gives three dimensional depth and spread to the sound, because the signal is output from the left, right, and center.

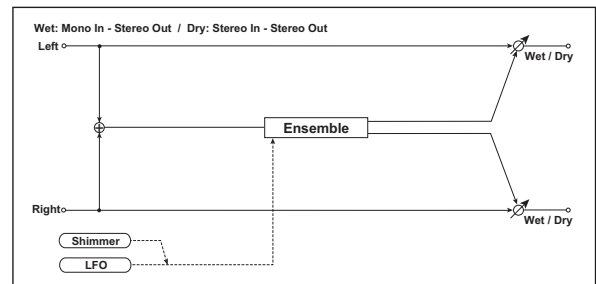

Full parameter	Quick parameter	Value	Explanation	
Speed	←	1...100	Sets the speed of the LFO	D ^{mod}
Source		Off...Tempo	Selects a modulation source for LFO speed	
Amount		-100...+100	Sets the modulation amount of LFO speed	
Depth	←	0...100	Sets the depth of LFO modulation	D ^{mod}
Source		Off...Tempo	Selects the modulation source of the LFO modulation depth	
Amount		-100...+100	Sets the modulation amount of the LFO modulation depth	
Shimmer		0...100	Sets the amount of shimmering of the LFO waveform p.253	
Wet/Dry	←	Dry, 1 : 99... 99 : 1, Wet	Sets the balance between the effect and the dry input	D ^{mod}
Source		Off...Tempo	Selects a modulation source for Wet/Dry	
Amount		-100...+100	Sets the modulation amount for Wet/Dry	

Shimmer

This parameter sets the amount of shimmering of the LFO waveform. Increasing this value adds more shimmering, making the chorus effect more complex and richer.

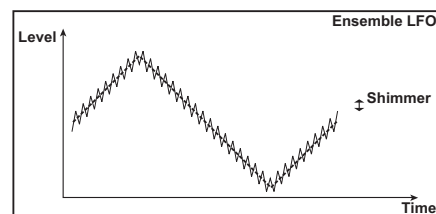

071: Poly6 Ens (Polysix Ensemble)

This models the ensemble effect built into the classic Korg PolySix programmable polyphonic synthesizer.

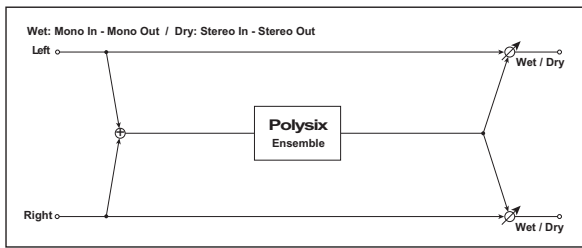

Full parameter	Quick parameter	Value	Explanation	
Depth	←	0...100	Sets the depth of the effect	
Source		Off...Tempo	Selects the modulation source that will control the effect depth	
Amount		-100...+100	Sets the amount by which the effect depth will be modulated	
Wet/Dry	←	Dry, 1 : 99... 99 : 1, Wet	Sets the balance between the effect and the dry input	
Source		Off...Tempo	Selects a modulation source for Wet/Dry	
Amount		-100...+100	Sets the modulation amount for Wet/Dry	

072: St Flange (Stereo Flanger)

This effect gives a significant swell and movement of pitch to the sound. It is more effective when applied to a sound with a lot of harmonics. This is a stereo flanger. You can add spread to the sound by offsetting the phase of the left and right LFOs from each other.

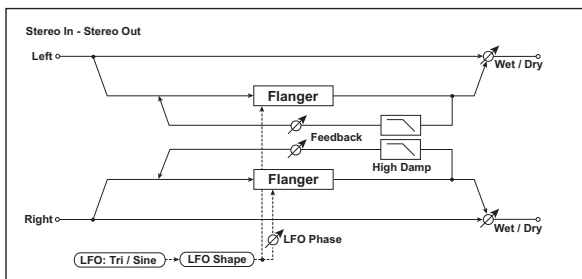

Full parameter	Quick parameter	Value	Explanation	
Delay Time [ms]	Delay[ms]	0.0...50.0	Sets the delay time from the original sound	
Depth		0...100	Sets the depth of LFO modulation	
Feedback		-100...+100	Sets the feedback amount p.254	
High Damp [%]		0...100	Sets the feedback damping amount in the high range p.254	
LFO Waveform		Triangle, Sine	Selects the LFO Waveform	
Shape		-100...+100	Changes the curvature of the LFO Waveform p.224	
Phase [deg]		-180...+180	Sets the LFO phase difference between the left and right p.225	
LFO Freq [Hz]	LFO [Hz]	0.02...20.00	Sets the speed of the LFO p.225	

Source		Off...Tempo	Selects a modulation source for LFO speed	
Amount		-20.00... +20.00	Sets the modulation amount of LFO speed	
BPM/MIDI Sync	LFO MIDI Sync	Off, On	When this is on, the LFO speed is set by BPM, Base Note, and Times, instead of Frequency p.223	
BPM		MIDI, 40.00... 300.00	MIDI syncs to the system tempo; 40-300 sets the tempo manually for this individual effect p.223	
Base Note			Selects the type of notes that specify the LFO speed p.223	
Times		x1...x32	Sets the number of notes that specify the LFO speed p.223	
Wet/Dry	←	-Wet... -1 : 99, Dry, 1 : 99...Wet	Sets the balance between the effect and the dry input p.225, p.254	
Source		Off...Tempo	Selects a modulation source for Wet/Dry	
Amount		-100...+100	Sets the modulation amount for Wet/Dry	

Feedback

Wet/Dry

The peak shape of the positive and negative “Feedback” value is different. The harmonics will be emphasized when the effect sound is mixed with the dry sound if you set a positive value for both “Feedback” and “Wet/Dry,” and if you set a negative value for both “Feedback” and “Wet/Dry.”

High Damp [%]

This parameter sets the amount of damping of the feedback in the high range. Increasing the value will cut high-range harmonics.

073: VtgFlange (Vintage Flanger)

This models a classic analog flanger. It is highly effective for chording on clavi-type keyboards or electric piano.

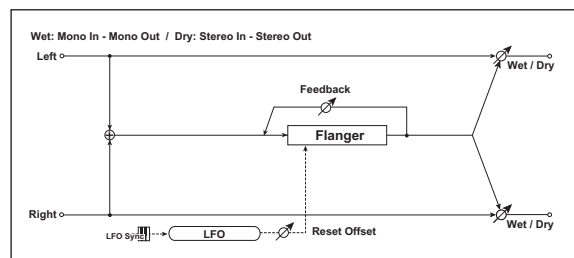

Full parameter	Quick parameter	Value	Explanation	
Speed [Hz]	←	0.10...10.0	Sets the speed of LFO	
Depth	←	0...100	Sets the depth of LFO modulation	
Resonance	←	0...100	Sets the resonance amount	
Manual	←	1...100	Sets the sweep frequency	
LFO Reset Source		Off...Tempo	Selects a modulation source for LFO reset	
Reset Offset		0...100	Sets the offset	
Wet/Dry	←	-Wet... -1 : 99, Dry, 1 : 99...Wet	Sets the balance between the effect and the dry input	
Source		Off...Tempo	Selects a modulation source for Wet/Dry	
Amount		-100...+100	Sets the modulation amount for Wet/Dry	

074: St.RndFlg (Stereo Random Flanger)

The stereo effect uses a step-shape waveform and random LFO for modulation, creating a unique flanging effect.

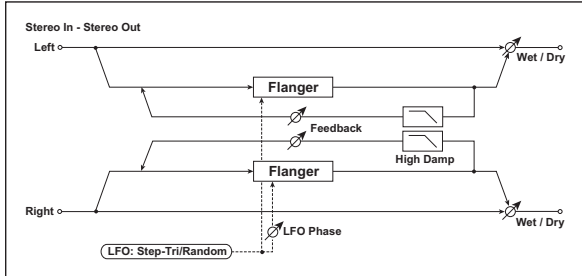

Full parameter	Quick parameter	Value	Explanation	
Delay Time [ms]	Delay[ms]	0.0...50.0	Sets the delay time from the original sound	
LFO Waveform	LFO	Step-Tri, Random	Selects the LFO Waveform p.225	
Phase [deg]		-180...+180	Sets the LFO phase difference between the left and right p.225	
LFO Freq [Hz]		0.02...20.00	Sets the speed of the LFO p.225	D-mod
Source		Off...Tempo	Selects the modulation source used for both LFO speed and step speed	
Amount		-20.00...+20.00	Sets the modulation amount of LFO speed	
Step Freq [Hz]	Step[Hz]	0.05...50.00	Sets the LFO step speed (speed that changes in steps)	D-mod
Amount		-50.00...+50.00	Sets the modulation amount of LFO step speed	
BPM/MIDI Sync	LFO MIDI Sync	Off, On	When this is on, the LFO speed is set by BPM, Base Note, and Times, instead of Frequency p.223	ASync
BPM		MIDI, 40.00...300.00	MIDI syncs to the system tempo; 40-300 sets the tempo manually for this individual effect p.223	
Base Note			Selects the type of notes that specify the LFO speed p.223	
Times		x1...x32	Sets the number of notes that specify the LFO speed p.223	
Step Base Note			Selects the type of notes to specify the LFO step speed p.225	ASync
Times		x1...x32	Sets the number of notes to specify the LFO step speed p.225	
Depth	←	0...100	Sets the depth of LFO modulation	
Feedback	←	-100...+100	Sets the feedback amount p.254	
High Damp [%]		0...100	Sets the feedback damping amount in the high range p.254	
Wet/Dry	←	-Wet...-1 : 99, Dry, 1 : 99...Wet	Sets the balance between the effect and the dry input p.225, p.254	D-mod
Source		Off...Tempo	Selects a modulation source for Wet/Dry	
Amount		-100...+100	Sets the modulation amount for Wet/Dry	

075: St.EnvFlg (Stereo Envelope Flanger)

This Flanger uses an envelope generator for modulation. You will obtain the same pattern of flanging each time you play. You can also control the Flanger directly using the modulation source.

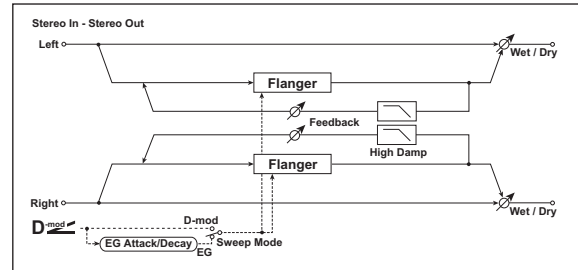

Full parameter	Quick parameter	Value	Explanation	
L Delay Time Bottom [ms]	L Btm[ms]	0.0...50.0	Sets the lower limit of the left-channel delay time	
L Delay Time Top [ms]	L Top[ms]	0.0...50.0	Sets the upper limit of the left-channel delay time	
R Delay Time Bottom [ms]	R Btm[ms]	0.0...50.0	Sets the lower limit of the right-channel delay time	
R Delay Time Top [ms]	R Top[ms]	0.0...50.0	Sets the upper limit of the right-channel delay time	
Sweep Mode	←	EG, D-mod	Determines whether the flanger is controlled by the envelope generator or by the modulation source p.255	
Source	Src	Off...Tempo	Selects the modulation source that triggers the EG (when Sweep Mode = EG), or the modulation source that causes the flanger to sweep (when Sweep Mode = D-mod) p.255	D-mod
EG Attack	←	1...100	Sets the EG attack speed p.256	
EG Decay	←	1...100	Sets the EG decay speed p.256	
Feedback	←	-100...+100	Sets the feedback amount p.254	
High Damp [%]		0...100	Sets the feedback damping amount in the high range p.254	
Wet/Dry	←	-Wet...-1 : 99, Dry, 1 : 99...Wet	Sets the balance between the effect and the dry input p.225, p.254	D-mod
Source		Off...Tempo	Selects a modulation source for Wet/Dry	
Amount		-100...+100	Sets the modulation amount for Wet/Dry	

Sweep Mode Source

This parameter switches the flanger control mode. With "Sweep Mode" = EG, the flanger will sweep using the envelope generator. This envelope generator is included in the envelope flanger, and not related to the Pitch EG, Filter EG, or Amp EG.

The "Source" parameter selects the source that starts the envelope generator. If you select, for example, Gate, the envelope generator will start when the note-on message is received.

When “Sweep Mode” = D-mod, the modulation source can control the flanger directly. Select the modulation source using the “Source” parameter.

MIDI The effect is off when a value for the modulation source specified for the “Source” parameter is smaller than 64, and the effect is on when the value is 64 or higher. The Envelope Generator is triggered when the value changes from 63 or smaller to 64 or higher.

EG Attack

EG Decay

Attack and Decay speed are the only adjustable parameters on this EG.

076: St.Vibrat (Stereo Vibrato)

This effect causes the pitch of the input signal to shimmer. Using the AutoFade allows you to increase or decrease the shimmering speed.

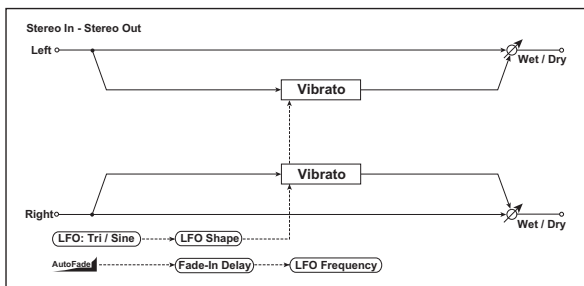

Full parameter	Quick parameter	Value	Explanation	
AUTOFADE Source		Off...Tempo	Selects the modulation source that starts AutoFade p.256	
Fade-In Delay [ms]		00...2000	Sets the fade-in delay time p.256	
Fade-In Rate		1...100	Sets the rate of fade-in p.256	
LFO Freq Mod	LFO Mod	D-mod, AUTOFADE	Switches between D-mod and AUTOFADE for the LFO frequency modulation p.256	
Vibrato Depth	Depth	0...100	Sets the depth of LFO modulation	
Source		Off...Tempo	Selects the modulation source of the LFO modulation depth	
Amount		-100...+100	Sets the modulation amount of the LFO modulation depth	
LFO Waveform		Triangle, Sine	Selects the LFO Waveform	
Shape		-100...+100	Changes the curvature of the LFO Waveform p.225	
LFO Freq [Hz]	LFO [Hz]	0.02...20.00	Sets the speed of the LFO	
Source	Src	Off...Tempo	Selects a modulation source for LFO speed	
Amount	Amt	-20.00...+20.00	Sets the modulation amount of LFO speed	
BPM/MIDI Sync	LFO MIDI Sync	Off, On	When this is on, the LFO speed is set by BPM, Base Note, and Times, instead of Frequency p.223	
BPM		MIDI, 40.00...300.00	MIDI syncs to the system tempo; 40-300 sets the tempo manually for this individual effect p.223	
Base Note			Selects the type of notes that specify the LFO speed p.223	

Times		x1...x32	Sets the number of notes that specify the LFO speed p.223	
Wet/Dry	←	Dry, 1 : 99... 99 : 1, Wet	Sets the balance between the effect and the dry input	
Source		Off...Tempo	Selects a modulation source for Wet/Dry	
Amount		-100...+100	Sets the modulation amount for Wet/Dry	

AUTOFADE Source

Fade-In Delay [ms]

Fade-In Rate

LFO Freq Mod

When “LFO Freq Mod” is set to AUTOFADE, you can use the modulation source selected in “AUTOFADE Source” as a trigger to automatically fade in the modulation amount. When “MIDI Sync” is set to On, you cannot use this.

The “Fade-In Rate” parameter specifies the rate of fade-in. The “Fade-In Delay” parameter determines the time from AutoFade modulation source On until the fade-in starts.

The following is an example of fade-in where the LFO speed is increased from “1.0Hz” to “4.0Hz” when a note-on message is received.

“AUTOFADE Source”=Gate1, “LFO Freq Mod” = AUTOFADE, “LFO Freq [Hz]”=1.0, “Amount”=3.0

MIDI The effect is off when a value for the dynamic modulation source specified for the “AUTOFADE Source” parameter is smaller than 64, and the effect is on when the value is 64 or higher. The AutoFade function is triggered when the value changes from 63 or smaller to 64 or higher.

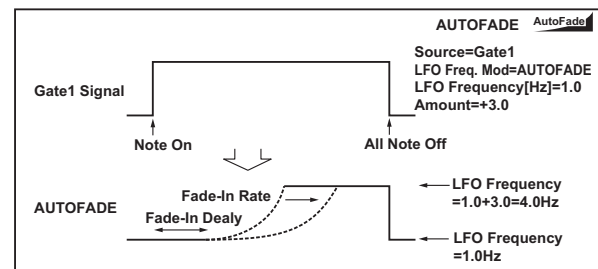

077: St.AF Mod (Stereo Auto Fade Modulation)

This stereo chorus/flanger effect enables you to control the LFO speed and effect balance using auto fade, and you can spread the sound by offsetting the phase of the left and right LFOs from each other.

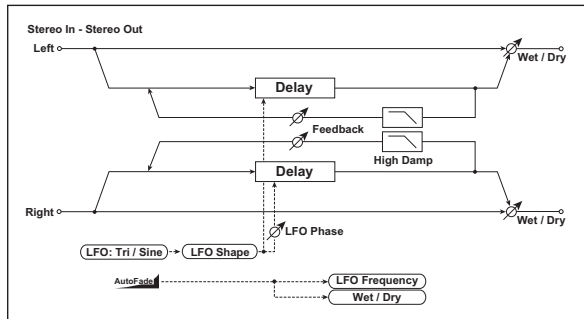

Full parameter	Quick parameter	Value	Explanation	
AUTOFADE Source		Off...Tempo	Selects the modulation source that starts AutoFade p.256	D-mod
Fade-In Rate		1...100	Sets the rate of fade-in p.256	
Fade-In Delay [ms]		00...2000	Sets the fade-in delay time p.256	
LFO Freq Mod	LFO Mod	D-mod, AUTOFADE	Switches between D-mod and AUTOFADE for the LFO frequency modulation p.256	
Wet/Dry Mod	W/D Mod	D-mod, AUTOFADE	Switches between D-mod and AUTOFADE for the effect balance modulation p.256	
Mod Delay L Delay [ms]	L Dly[ms]	0.0...500.0	Sets the left channel delay time	
Mod Delay R Delay [ms]	R Dly[ms]	0.0...500.0	Sets the right channel delay time	
Depth	←	0...200	Sets the depth of LFO modulation	
Feedback	←	-100...+100	Sets the feedback amount p.254	
High Damp [%]		0...100	Sets the feedback damping amount in the high range p.254	
LFO Waveform		Triangle, Sine	Selects the LFO Waveform	
Shape		-100...+100	Changes the curvature of the LFO Waveform p.224	
Phase [deg]		-180...+180	Sets the LFO phase difference between the left and right p.225	
LFO Freq [Hz]	LFO [Hz]	0.02...20.00	Sets the speed of the LFO	D-mod
Source	Src	Off...Tempo	Selects a modulation source for LFO speed	
Amount [Hz]	Amt	-20.00...+20.00	Sets the modulation amount of LFO speed	
Wet/Dry	←	-Wet...-1 : 99, Dry, 1 : 99...Wet	Sets the balance between the effect and the dry input p.225, p.254	D-mod
Source	Src	Off...Tempo	Selects a modulation source for Wet/Dry	
Amount	Amt	-100...+100	Sets the modulation amount for Wet/Dry	

078: Doppler

This effect simulates the “Doppler effect” of a moving sound with a changing pitch, similar to the siren of an passing ambulance. Mixing the effect sound with the dry sound will create a unique chorus effect.

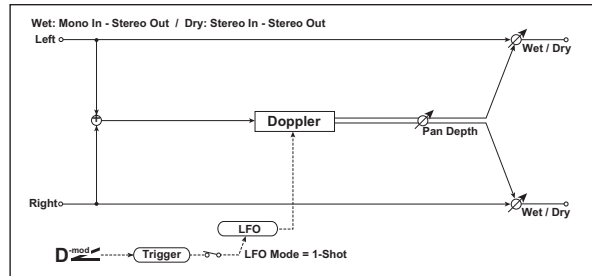

Full parameter	Quick parameter	Value	Explanation	
Pitch Depth	←	0...100	Sets the pitch variation of the moving sound p.258	D-mod
Source		Off...Tempo	Selects the modulation source of pitch variation	
Amount		-100...+100	Sets the modulation amount of pitch variation	
Pan Depth	←	-100...+100	Sets the panning of the moving sound p.258	D-mod
Source		Off...Tempo	Selects the modulation source of panning	
Amount		-100...+100	Sets the modulation amount of panning	
LFO Mode	←	Loop, 1-Shot	Switches LFO operation mode p.257	
Source		Off...Tempo	Selects the modulation source of LFO reset p.257	D-mod
LFO Sync		Off, On	Switches between LFO reset on and off when LFO Mode is set to Loop p.257	
LFO Freq [Hz]	LFO [Hz]	0.02...20.00	Sets the speed of the LFO p.225	D-mod
Source		Off...Tempo	Selects a modulation source for LFO speed	
Amount		-20.00...+20.00	Sets the modulation amount of LFO speed	
BPM/MIDI Sync	LFO MIDI Sync	Off, On	When this is on, the LFO speed is set by BPM, Base Note, and Times, instead of Frequency p.223	aj
BPM		MIDI, 40.00...300.00	MIDI syncs to the system tempo; 40-300 sets the tempo manually for this individual effect p.223	
Base Note			Selects the type of notes that specify the LFO speed p.223	
Times		x1...x32	Sets the number of notes that specify the LFO speed p.223	
Wet/Dry	←	Dry, 1 : 99...99 : 1, Wet	Sets the balance between the effect and the dry input	D-mod
Source		Off...Tempo	Selects a modulation source for Wet/Dry	
Amount		-100...+100	Sets the modulation amount for Wet/Dry	

LFO Mode

Source

LFO Sync

The “LFO Mode” parameter switches LFO operation mode. When Loop is selected, the Doppler effect will be created

repeatedly. If "LFO Sync" is set to On, the LFO will be reset when the modulation source specified with the "Source" parameter is turned on.

When "LFO Mode" is set to 1-Shot, the Doppler effect is created only once when the modulation source specified in the "Source" field is turned on. At this time if you do not set the "Source" parameter, the Doppler effect will not be created, and no effect sound will be output.

MIDI The effect is off when a value for the modulation source specified for the "Source" parameter is smaller than 64, and the effect is on when the value is 64 or higher. The Doppler effect is triggered when the value changes from 63 or smaller to 64 or higher.

Pitch Depth

With the Doppler effect, the pitch is raised when the sound approaches, and the pitch is lowered when the sound goes away. This parameter sets this pitch variation.

Pan Depth

This parameter sets the width of the stereo image of the effect sound. With larger values, the sound seems to come and go from much further away. With positive values, the sound moves from left to right; with negative values, the sound moves from right to left.

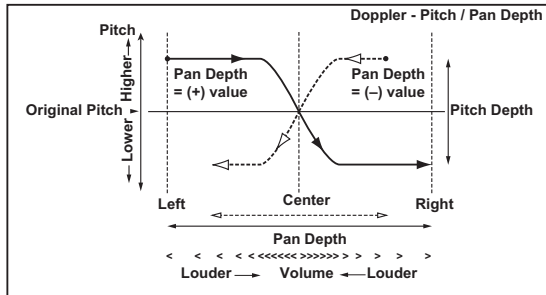

079: Detune

Using this effect, you can obtain a detune effect that offsets the pitch of the effect sound slightly from the pitch of the input signal. Compared to the chorus effect, a more natural sound thickness will be created.

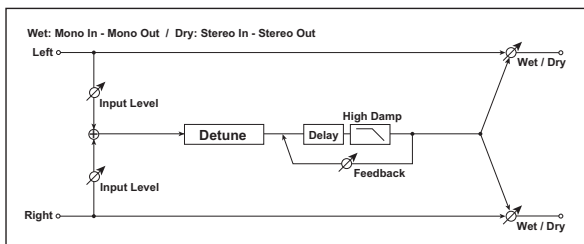

Full parameter	Quick parameter	Value	Explanation
Input Lvl Dmod [%]		-100...+100	Sets the modulation amount of the input level p.258
Source		Off...Tempo	Selects the modulation source for the input level p.258
Pitch Shift [cents]	Pitch [c]	-100...+100	Sets the pitch difference from the input signal
Source		Off...Tempo	Selects a modulation source for pitch shift
Amount		-100...+100	Sets the modulation amount for pitch shift
Delay Time [ms]		0...1000	Sets the delay time
Feedback		-100...+100	Sets the feedback amount

High Damp [%]		0...100	Sets the damping amount in the high range
Wet/Dry	←	Dry, 1 : 99... 99 : 1, Wet	Sets the balance between the effect and the dry input
Source		Off...Tempo	Selects a modulation source for Wet/Dry
Amount		-100...+100	Sets the modulation amount for Wet/Dry

Input Lvl Dmod [%]

Source

This parameter sets the dynamic modulation of the input level.

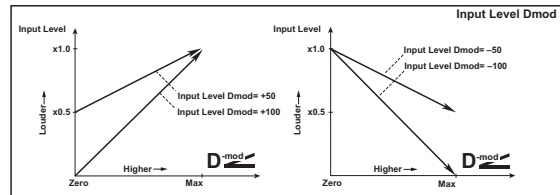

080: PitchSftr (Pitch Shifter)

This effect changes the pitch of the input signal. You can select from three types: Fast (quick response), Medium, and Slow (preserves tonal quality). You can also create an effect in which the pitch is gradually raised (or dropped) using the delay with feedback.

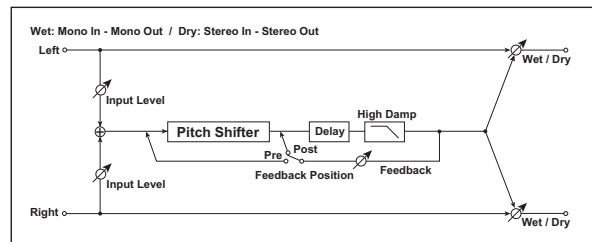

Full parameter	Quick parameter	Value	Explanation
Input Lvl Dmod [%]		-100...+100	Sets the modulation amount of the input level p.258
Source		Off...Tempo	Selects the modulation source for the input level p.258
Mode	←	Slow, Medium, Fast	Switches Pitch Shifter mode p.259
Shift [1/2tone]	Pitch	-24...+24	Sets the pitch shift amount by steps of a semitone p.259
Source		Off...Tempo	Selects the modulation source of pitch shift amount p.259
Amount		-24...+24	Sets the modulation amount of pitch shift amount p.259
Fine [cents]	Fine [c]	-100...+100	Sets the pitch shift amount by steps of a cent p.259
Amount [cents]		-100...+100	Sets the modulation amount of pitch shift amount p.259
Delay Time [ms]		0...2000	Sets the delay time
Feedback Position		Pre, Post	Switches the feedback connection p.259
Feedback		-100...+100	Sets the feedback amount p.259
High Damp [%]		0...100	Sets the damping amount in the high range

Wet/Dry	←	Dry, 1 : 99... 99 : 1, Wet	Sets the balance between the effect and the dry input	D ^{mod}
Source		Off...Tempo	Selects a modulation source for Wet/Dry	
Amount		-100...+100	Sets the modulation amount for Wet/Dry	

Mode

This parameter switches the pitch shifter operating mode. With Slow, tonal quality will not be changed too much. With Fast, the effect becomes a Pitch Shifter that has a quick response, but may change the tone. Medium is in-between these two. If you do not need to set too much pitch shift amount, set this parameter to Slow. If you wish to change the pitch significantly, use Fast.

Shift [1/2tone]

Source

Amount

Fine [cents]

Amount [cents]

The amount of pitch shift will use the value of the "Pitch Shift" plus the "Fine" value. The amount of modulation will use the Pitch Shift Amount value plus the Fine Amount. The same Modulation Source is used for both "Pitch Shift" and "Fine."

Feedback Position

Feedback

When "Feedback Position" is set to **Pre**, the pitch shifter output is again input to the pitch shifter. Therefore, if you specify a higher value for the Feedback parameter, the pitch will be raised (or lowered) more and more each time feedback is repeated.

If "Feedback Position" is set to **Post**, the feedback signal will not pass through the pitch shifter again. Even if you specify a higher value for the "Feedback" parameter, the pitch-shifted sound will be repeated at the same pitch.

081: P.Sft Mod (Pitch Shift Modulation)

This effect modulates the detuned pitch shift amount using an LFO, adding a clear spread and width to the sound by panning the effect sound and dry sound to the left and right. This is especially effective when the effect sound and dry sound output from stereo speakers are mixed.

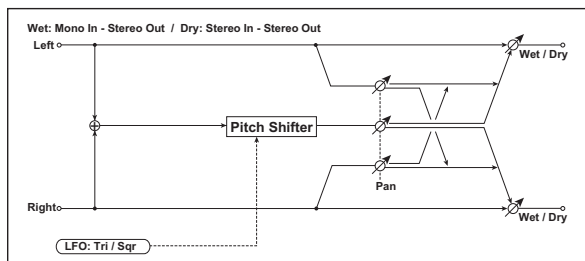

Full parameter	Quick parameter	Value	Explanation	
Pitch Shift [cents]	Pitch [c]	-100...+100	Sets the pitch difference from the input signal p.259	
Depth	←	-100...+100	Sets the LFO modulation depth for pitch shift amount p.259	D ^{mod}
Source		Off...Tempo	Selects the modulation source of the depth of modulation	

Amount		-100...+100	Sets the modulation amount of the depth of modulation	
Pan	←	L, 1 : 99...99 : 1, R	Sets the panning effect sound and dry sound separately p.259	
LFO Waveform		Triangle, Square	Selects the LFO Waveform	
LFO Freq [Hz]	LFO [Hz]	0.02...20.00	Sets the speed of the LFO p.225	D ^{mod}
Source		Off...Tempo	Selects a modulation source for LFO speed	
Amount		-20.00...+20.00	Sets the modulation amount of LFO speed	
BPM/MIDI Sync	LFO MIDI Sync	Off, On	When this is on, the LFO speed is set by BPM, Base Note, and Times, instead of Frequency p.223	A ^{sync}
BPM		MIDI, 40.00...300.00	MIDI syncs to the system tempo; 40-300 sets the tempo manually for this individual effect p.223	
Base Note		♩...♩	Selects the type of notes that specify the LFO speed p.223	
Times		x1...x32	Sets the number of notes that specify the LFO speed p.223	
Wet/Dry	←	Dry, 1 : 99...99 : 1, Wet	Sets the balance between the effect and the dry input p.259	D ^{mod}
Source		Off...Tempo	Selects a modulation source for Wet/Dry	
Amount		-100...+100	Sets the modulation amount for Wet/Dry	

Pitch Shift [cents]

Depth

These parameters set the amount of pitch shift and amount of modulation by means of the LFO.

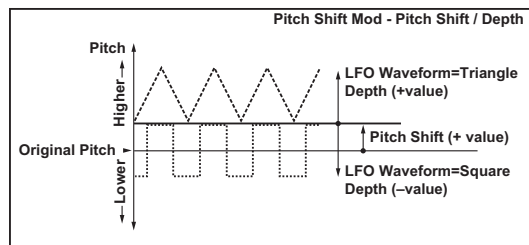

Pan

Wet/Dry

The Pan parameter pans the effect sound and dry sound to the left and right. With L, the effect sound is panned left, and the dry sound is panned right. With a Wet/Dry = Wet setting, the effect and dry sound will be output in a proportion of 1:1.

082: P4EQ - Flng (Parametric 4-Band EQ - Chorus/Flanger)

This effect combines a mono four-band parametric equalizer and a chorus/flanger.

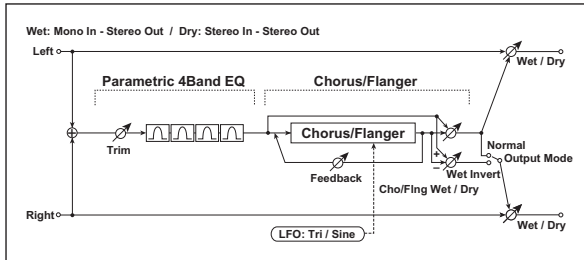

Full parameter	Quick parameter	Value	Explanation
Parametric 4-Band EQ			
Trim	E Trim	0...100	Sets the parametric EQ input level
Band1 Cutoff [Hz]	E1 F[Hz]	20...1.00k	Sets the center frequency of Band 1
Band1 Q	E1 Q	0.5...10.0	Sets the bandwidth of Band 1 p.221
Band1 Gain [dB]	E1 G[dB]	-18...+18	Sets the gain of Band 1
Band2 Cutoff [Hz]	E2 F[Hz]	50...5.00k	Sets the center frequency of Band 2
Band2 Q	E2 Q	0.5...10.0	Sets the bandwidth of Band 2 p.221
Band2 Gain [dB]	E2 G[dB]	-18...+18	Sets the gain of Band 2
Band3 Cutoff [Hz]	E3 F[Hz]	300...10.00k	Sets the center frequency of Band 3
Band3 Q	E3 Q	0.5...10.0	Sets the bandwidth of Band 3 p.221
Band3 Gain [dB]	E3 G[dB]	-18...+18	Sets the gain of Band 3
Band4 Cutoff [Hz]	E4 F[Hz]	500...20.00k	Sets the center frequency of Band 4
Band4 Q	E4 Q	0.5...10.0	Sets the bandwidth of Band 4 p.221
Band4 Gain [dB]	E4 G[dB]	-18...+18	Sets the gain of Band 4
Chorus/Flanger			
LFO Waveform		Triangle, Sine	Selects the LFO Waveform
LFO Freq [Hz]	F LFO[Hz]	0.02...20.00	Sets the speed of the LFO
Delay Time [ms]	F Dly[ms]	0.0...1350.0	Sets the delay time
Depth	F Depth	0...100	Sets the depth of LFO modulation
Feedback	F F.back	-100...+100	Sets the feedback amount p.254
Output Mode	F Out	Normal, Wet Invert	Selects the output mode for the chorus/flanger p.261
[Cho/Fln] Wet/Dry	F W/D	-Wet...-1 : 99, Dry, 1 : 99...Wet	Sets the effect balance of the chorus/flanger p.225, p.254
[Cho/Fln] Source		Off...Tempo	Selects the Wet/Dry modulation source for the chorus/flanger
[Cho/Fln] Amount		-100...+100	Sets the Wet/Dry modulation amount for the chorus/flanger
Wet/Dry	←	Dry, 1 : 99... 99 : 1, Wet	Sets the balance between the effect and the dry input
Source		Off...Tempo	Selects a modulation source for Wet/Dry
Amount		-100...+100	Sets the modulation amount for Wet/Dry

Output Mode

When Wet Invert is selected, the right channel phase of the chorus/flanger effect sound is inverted. This creates pseudo-stereo effects and adds spread.

However, if a mono-input type effect is connected after this effect, the left and right sounds may cancel each other, eliminating the chorus/flanger effects.

083: Comp - Flng (Compressor - Chorus/Flanger)

This effect combines a mono compressor and a chorus/flanger. You can change the order of the effects.

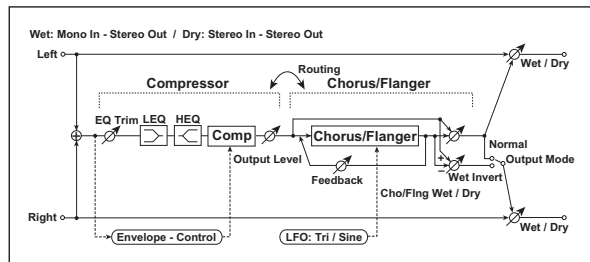

Full parameter	Quick parameter	Value	Explanation
Compressor			
Sensitivity	C Sens	1...100	Sets the sensitivity p.217
Attack	C Attack	1...100	Sets the attack level p.217
Level	C Level	0...100	Sets the compressor output level p.217
Pre EQ Trim		0...100	Sets the EQ input level
LEQ Gain [dB]		-15...+15	Sets the gain of Low EQ
HEQ Gain [dB]		-15...+15	Sets the gain of High EQ
Chorus/Flanger			
LFO Waveform		Triangle, Sine	Selects the LFO Waveform
LFO Freq [Hz]	F LFO[Hz]	0.02...20.00	Sets the speed of the LFO
Delay Time [ms]	F Dly[ms]	0.0...1350.0	Sets the delay time
Depth	F Depth	0...100	Sets the depth of LFO modulation
Feedback	F F.back	-100...+100	Sets the feedback amount p.254
Output Mode	F Out	Normal, Wet Invert	Selects the output mode for the chorus/flanger p.261
[Cho/Fln] Wet/Dry	F W/D	-Wet...-1 : 99, Dry, 1 : 99...Wet	Sets the effect balance of the chorus/flanger p.225, p.254
[Cho/Fln] Source		Off...Tempo	Selects the Wet/Dry modulation source for the chorus/flanger
[Cho/Fln] Amount		-100...+100	Sets the Wet/Dry modulation amount for the chorus/flanger
Routing	Route	Cmp → Flg, Flg → Cmp	Switches the order of the compressor and chorus/flanger p.261
Wet/Dry	←	Dry, 1 : 99... 99 : 1, Wet	Sets the balance between the effect and the dry input
Source		Off...Tempo	Selects a modulation source for Wet/Dry
Amount		-100...+100	Sets the modulation amount for Wet/Dry

Output Mode

Routing

When Wet Invert is selected, the right channel phase of the chorus/flanger effect sound is inverted. This creates pseudo-stereo effects and adds spread.

However, if a mono-input type effect is connected after this effect, the left and right sounds may cancel each other, eliminating the chorus/flanger effects.

When "Routing" is set to Flanger→Comp, "Output Mode" will be set to Normal.

084: Lmtr - Flng (Limiter - Chorus/Flanger)

This effect combines a mono limiter and a chorus/flanger. You can change the order of the effects.

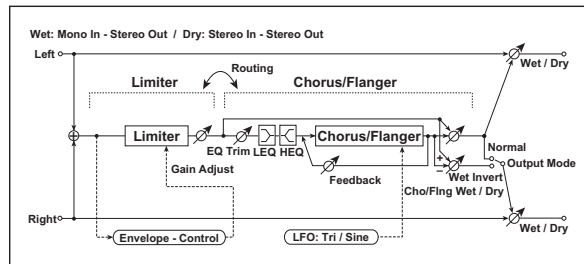

Full parameter	Quick parameter	Value	Explanation
Limiter			
Ratio	L Ratio	1.0 : 1... 50.0 : 1, Inf : 1	Sets the signal compression ratio p.244
Threshold [dB]	L Trsh[dB]	-40...0	Sets the level above which the compressor is applied p.244
Attack	L Attack	1...100	Sets the attack time
Release	L Release	1...100	Sets the release time
Gain Adjust [dB]	L G [dB]	-Inf, -38...+24	Sets the limiter output gain p.244
Chorus/Flanger			
LFO Waveform		Triangle, Sine	Selects the LFO Waveform
LFO Freq [Hz]	F LFO[Hz]	0.02...20.00	Sets the speed of the LFO
Delay Time [ms]	F Dly[ms]	0.0...1350.0	Sets the delay time
Depth	F Depth	0...100	Sets the depth of LFO modulation
Feedback	F F.back	-100...+100	Sets the feedback amount p.254
Pre EQ Trim		0...100	Sets the EQ input level
LEQ Gain [dB]		-15...+15	Sets the gain of Low EQ
HEQ Gain [dB]		-15...+15	Sets the gain of High EQ
Output Mode	F Out	Normal, Wet Invert	Selects the output mode for the chorus/flanger p.261
[Cho/Fln] Wet/Dry	F W/D	-Wet... -1 : 99, Dry, 1 : 99...Wet	Sets the effect balance of the chorus/flanger p.225, p.254
[Cho/Fln] Source		Off...Tempo	Selects the Wet/Dry modulation source for the chorus/flanger
[Cho/Fln] Amount		-100...+100	Sets the Wet/Dry modulation amount for the chorus/flanger
Routing	Route	Lmt→Flg, Flg→Lmt	Switches the order of the limiter and chorus/flanger
Wet/Dry	←	Dry, 1 : 99... 99 : 1, Wet	Sets the balance between the effect and the dry input

Source		Off...Tempo	Selects a modulation source for Wet/Dry
Amount		-100...+100	Sets the modulation amount for Wet/Dry

085: Xctr - Flng (Exciter - Chorus/Flanger)

This effect combines a mono limiter and a chorus/flanger.

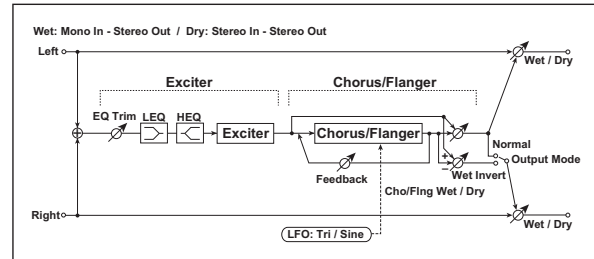

Full parameter	Quick parameter	Value	Explanation
Exciter			
Blend	X Blend	-100...+100	Sets the intensity (depth) of the Exciter effect p.222
Emphasis Freq	X Freq	0...70	Sets the frequency range to be emphasized p.222
Trim		0...100	Sets the EQ input level
LEQ Gain [dB]		-15...+15	Sets the gain of Low EQ
HEQ Gain [dB]		-15...+15	Sets the gain of High EQ
Chorus/Flanger			
LFO Waveform		Triangle, Sine	Selects the LFO Waveform
LFO Freq [Hz]	F LFO[Hz]	0.02...20.00	Sets the speed of the LFO
Delay Time [ms]	F Dly[ms]	0.0...1350.0	Sets the delay time
Depth	F Depth	0...100	Sets the depth of LFO modulation
Feedback	F F.back	-100...+100	Sets the feedback amount p.254
Output Mode	F Out	Normal, Wet Invert	Selects the output mode for the chorus/flanger p.260
[Cho/Fln] Wet/Dry	F W/D	-Wet... -1 : 99, Dry, 1 : 99...Wet	Sets the effect balance of the chorus/flanger p.225, p.254
[Cho/Fln] Source		Off...Tempo	Selects the Wet/Dry modulation source for the chorus/flanger
[Cho/Fln] Amount		-100...+100	Sets the Wet/Dry modulation amount for the chorus/flanger
Wet/Dry	Route	Dry, 1 : 99... 99 : 1, Wet	Sets the balance between the effect and the dry input
Source	Src	Off...Tempo	Selects a modulation source for Wet/Dry
Amount		-100...+100	Sets the modulation amount for Wet/Dry

086: OD - Fng (Overdrive/Hi.Gain - Chorus/Flanger)

This effect combines a mono overdrive/high-gain distortion and a chorus/flanger. You can change the order of the effects.

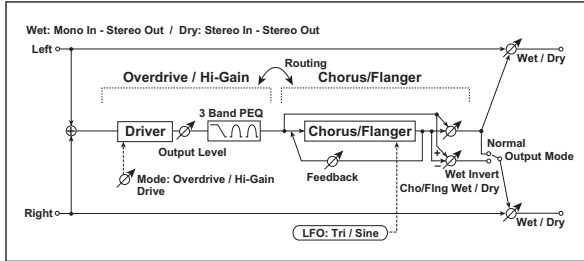

Full parameter	Quick parameter	Value	Explanation
Overdrive/Hi-Gain			
Drive Mode	O Mode	Overdrive, Hi-Gain	Switches between overdrive and high-gain distortion
Drive	O Drive	1...100	Sets the degree of distortion p.229
Level	O Out Level	0...50	Sets the overdrive output level p.229
Source		Off...Tempo	Selects the modulation source for the overdrive output level
Amount		-50...+50	Sets the modulation amount of the overdrive output level
Low Cutoff [Hz]		20...1.00k	Sets the center frequency for Low EQ (shelving type)
Low Gain [dB]	O Low [dB]	-18...+18	Sets the gain of Low EQ
Mid1 Cutoff [Hz]		300...10.00k	Sets the center frequency for Mid/High EQ 1 (peaking type)
Mid1 Q		0.5...10.0	Sets the band width of Mid/High EQ 1 p.221
Mid1 Gain [dB]	O Mid1 [dB]	-18...+18	Sets the gain of Mid/High EQ 1
Mid2 Cutoff [Hz]		500...20.00k	Sets the center frequency for Mid/High EQ 2 (peaking type)
Mid2 Q		0.5...10.0	Sets the band width of Mid/High EQ 2 p.221
Mid2 Gain [dB]	O Mid2 [dB]	-18...+18	Sets the gain of Mid/High EQ 2
Chorus/Flanger			
LFO Waveform		Triangle, Sine	Selects the LFO Waveform
LFO Freq [Hz]	F LFO[Hz]	0.02...20.00	Sets the speed of the LFO
Delay Time [ms]	F Dly[ms]	0.0...1350.0	Sets the delay time
Depth	F Depth	0...100	Sets the depth of LFO modulation
Feedback	F F.back	-100...+100	Sets the feedback amount p.254
Output Mode	F Out	Normal, Wet Invert	Selects the output mode for the chorus/flanger p.261
[Cho/Fln] Wet/Dry	F W/D	-Wet...-1 : 99, Dry, 1 : 99...Wet	Sets the effect balance of the chorus/flanger p.225, p.254
[Cho/Fln] Source		Off...Tempo	Selects the Wet/Dry modulation source for the chorus/flanger
[Cho/Fln] Amount		-100...+100	Sets the Wet/Dry modulation amount for the chorus/flanger

Routing	Route	OD → Flg, Flg → OD	Switches the order of the overdrive and chorus / flanger
Wet/Dry	←	Dry, 1 : 99... 99 : 1, Wet	Sets the balance between the effect and the dry input D ^{mod}
Source		Off...Tempo	Selects a modulation source for Wet/Dry
Amount		-100...+100	Sets the modulation amount for Wet/Dry

087: Phsr - Fng (Phaser - Chorus/Flanger)

This effect combines a mono phaser and a chorus/flanger.

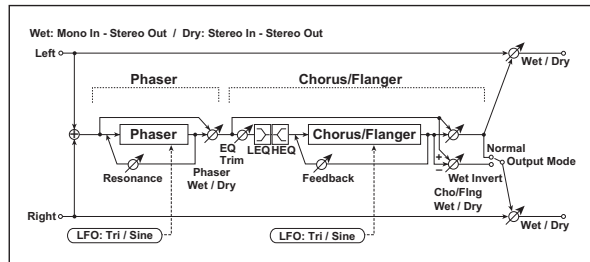

Full parameter	Quick parameter	Value	Explanation
Phaser			
LFO Waveform		Triangle, Sine	Selects the LFO Waveform
LFO Freq [Hz]	P LFO[Hz]	0.02...20.00	Sets the speed of the LFO
Manual	P Manual	0...100	Sets the frequency where the effect is applied
Depth	P Depth	0...100	Sets the depth of LFO modulation
Resonance	P Reso	-100...+100	Sets the resonance amount p.233
Wet/Dry	P W/D	-Wet...-1 : 99, Dry, 1 : 99...Wet	Sets the phaser effect balance p.225, p.233
Chorus/Flanger			
LFO Waveform		Triangle, Sine	Selects the LFO Waveform
LFO Freq [Hz]	F LFO[Hz]	0.02...20.00	Sets the speed of the LFO
Delay Time [ms]	F Dly[ms]	0.0...1350.0	Sets the delay time
Depth	F Depth	0...100	Sets the depth of LFO modulation
Feedback	F F.back	-100...+100	Sets the feedback amount p.254
Pre EQ Trim		0...100	Sets the EQ input level
LEQ Gain [dB]		-15...+15	Sets the gain of Low EQ
HEQ Gain [dB]		-15...+15	Sets the gain of High EQ
Output Mode	F Out	Normal, Wet Invert	Selects the output mode for the chorus/flanger p.260
[Cho/Fln] Wet/Dry	F W/D	-Wet...-1 : 99, Dry, 1 : 99...Wet	Sets the effect balance of the chorus/flanger p.225, p.254
[Cho/Fln] Source		Off...Tempo	Selects the Wet/Dry modulation source for the chorus/flanger
[Cho/Fln] Amount		-100...+100	Sets the Wet/Dry modulation amount for the chorus/flanger
Wet/Dry	←	Dry, 1 : 99... 99 : 1, Wet	Sets the balance between the effect and the dry input D ^{mod}
Source		Off...Tempo	Selects a modulation source for Wet/Dry

Amount		-100...+100	Sets the modulation amount for Wet/Dry	
--------	--	-------------	--	--

088: GrainSftr (Grain Shifter)

This effect cuts extremely short samples (“grains”) from the input signal waveform and plays them repeatedly, giving a mechanical character to the sound.

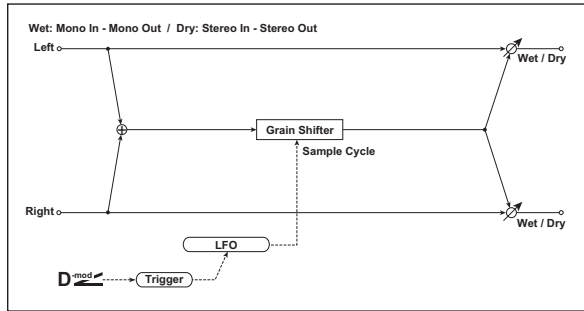

Full parameter	Quick parameter	Value	Explanation	
Duration	←	0...100	Sets the duration of the grain p.263	D ^{mod}
Source		Off...Tempo	Selects the source that will modulate the duration of the grain	
Amount		-100...+100	Sets the amount by which the grain duration will be modulated	
LFO Sync Src		Off...Tempo	Selects the modulation source that will reset the LFO	D ^{mod}
LFO Sample Cycle [Hz]	LFO [Hz]	0.02...20.00	Sets the frequency at which the grain will be switched p.263	D ^{mod}
Source		Off...Tempo	Selects a modulation source for LFO speed	
Amount		-20.00...+20.00	Sets the modulation amount of LFO speed	
BPM/MIDI Sync	LFO MIDI Sync	Off, On	When this is on, the LFO speed is set by BPM, Base Note, and Times, instead of Frequency p.223	D ^{mod} Sync
BPM		MIDI, 40.00...300.00	MIDI syncs to the system tempo; 40–300 sets the tempo manually for this individual effect p.223	
Base Note			Selects the type of notes that specify the LFO speed p.223	
Times		x1...x32	Sets the number of notes that specify the LFO speed p.223	
Wet/Dry	←	Dry, 1 : 99... 99 : 1, Wet	Sets the balance between the effect and the dry input	D ^{mod}
Source		Off...Tempo	Selects a modulation source for Wet/Dry	
Amount		-100...+100	Sets the modulation amount for Wet/Dry	

Duration

LFO Sample Cycle [Hz]

“Duration” sets the length of the sampled grain, and the “LFO Sample Cycle” controls how often a new grain is sampled. In between Sample Cycles, the current grain is repeated continuously.

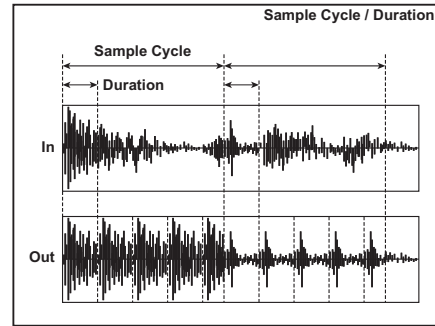

089: LCR Delay

This multitap delay outputs three Tap signals to the left, right, and center respectively. You can also adjust the left and right spread of the delay sound.

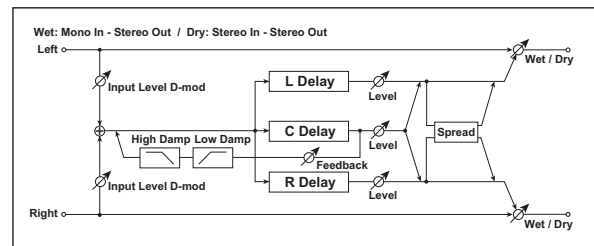

Full parameter	Quick parameter	Value	Explanation	
Input Level Dmod [%]		-100...+100	Sets the modulation amount of the input level p.258	D ^{mod}
Source		Off...Tempo	Selects the modulation source for the input level p.258	
High Damp [%]	Hi Damp[%]	0...100	Sets the damping amount in the high range p.264	
Low Damp [%]	Lo Damp[%]	0...100	Sets the damping amount in the low range p.264	
Spread		0...50	Sets the width of the stereo image of the effect sound p.264	
L Delay Time [ms]	L Dly[ms]	0...2730	Sets the delay time of TapL	
Level	L Level	0...50	Sets the output level of TapL	
C Delay Time [ms]	C Dly[ms]	0...2730	Sets the delay time of TapC	
Level	C Level	0...50	Sets the output level of TapC	
C Delay Feedback	Feedback	-100...+100	Sets the feedback amount of TapC	D ^{mod}
Source		Off...Tempo	Selects the modulation source of the TapC feedback amount	
Amount		-100...+100	Sets the modulation amount of the TapC feedback amount	
R Delay Time [ms]	R Delay[ms]	0...2730	Sets the delay time of TapR	
Level	R Level	0...50	Sets the output level of TapR	
Wet/Dry	←	Dry, 1 : 99... 99 : 1, Wet	Sets the balance between the effect and the dry input	D ^{mod}
Source		Off...Tempo	Selects a modulation source for Wet/Dry	
Amount		-100...+100	Sets the modulation amount for Wet/Dry	

High Damp [%]

Low Damp [%]

These parameters set the damping amount of high range and low range. The tone of the delayed sound becomes darker and lighter as it feeds back.

Spread

This parameter sets the pan width of the effect sound. The stereo image is widest with a value of 50, and the effect sound of both channels is output from the center with a value of 0.

090: St.Delay (Stereo/CrossDelay)

This is a stereo delay, and can be used as a cross-feedback delay effect in which the delay sounds cross over between the left and right by changing the feedback routing.

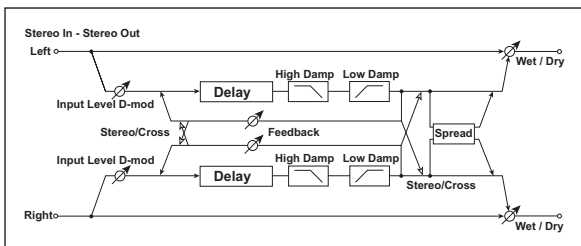

Full parameter	Quick parameter	Value	Explanation	
Input Level Dmod [%]		-100...+100	Sets the modulation amount of the input level p.258	D ^{mod}
Source		Off...Tempo	Selects the modulation source for the input level p.258	
Stereo/Cross	Mode	Stereo, Cross	Switches between stereo delay and cross-feedback delay	
L Delay [ms]	L DL[ms]	0.0...274.0	Sets the delay time for the left channel	
R Delay [ms]	R DL[ms]	0.0...274.0	Sets the delay time for the right channel	
L Feedback	L F.back	-100...+100	Sets the feedback amount for the left channel	D ^{mod}
Source		Off...Tempo	Selects the modulation source of feedback amount	
Amount		-100...+100	Sets the modulation amount of the left channel feedback	
R Feedback	R F.back	-100...+100	Sets the feedback amount for the right channel	D ^{mod}
Amount		-100...+100	Sets the modulation amount of the right channel feedback	
High Damp [%]	Hi Damp[%]	0...100	Sets the damping amount in the high range p.264	
Low Damp [%]	Lo Damp[%]	0...100	Sets the damping amount in the low range p.264	
Spread		-50...+50	Sets the width of the stereo image of the effect sound p.264	
Wet/Dry	←	Dry, 1 : 99... 99 : 1, Wet	Sets the balance between the effect and the dry input	D ^{mod}
Source		Off...Tempo	Selects a modulation source for Wet/Dry	
Amount		-100...+100	Sets the modulation amount for Wet/Dry	

091: St.MtpDly (Stereo Multitap Delay)

The left and right Multitap Delays have two taps respectively. Changing the routing of feedback and tap output allows you to create various patterns of complex effect sounds.

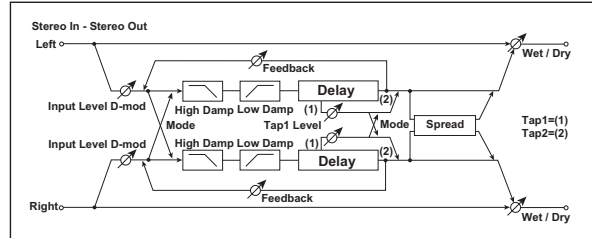

Full parameter	Quick parameter	Value	Explanation	
Input Level Dmod [%]		-100...+100	Sets the modulation amount of the input level p.258	D ^{mod}
Source		Off...Tempo	Selects the modulation source for the input level p.258	
Mode	←	Normal, Cross Feedback, Cross Pan1, Cross Pan2	Switches the left and right delay routing p.264	
High Damp [%]	Hi Damp[%]	0...100	Sets the damping amount in the high range p.264	
Low Damp [%]	Lo Damp[%]	0...100	Sets the damping amount in the low range p.264	
Tap1 Time [ms]	Tap1[ms]	0.0...274.0	Sets the Tap1 delay time	
Level		0...100	Sets the Tap1 output level p.265	
Tap2 Time [ms]	Tap2[ms]	0.0...274.0	Sets the Tap2 delay time	
Feedback		-100...+100	Sets the Tap2 feedback amount	D ^{mod}
Source		Off...Tempo	Selects the modulation source of the Tap2 feedback amount	
Amount		-100...+100	Sets the modulation amount of the Tap2 feedback amount	
Spread		-100...+100	Sets the width of the stereo image of the effect sound p.264	D ^{mod}
Source		Off...Tempo	Selects the modulation source of the effect sound's stereo image width	
Amount		-100...+100	Sets the modulation amount of the effect sound's stereo image width	
Wet/Dry	←	Dry, 1 : 99... 99 : 1, Wet	Sets the balance between the effect and the dry input	D ^{mod}
Source		Off...Tempo	Selects a modulation source for Wet/Dry	
Amount		-100...+100	Sets the modulation amount for Wet/Dry	

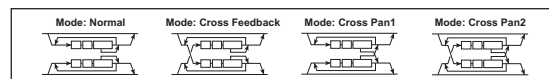

Mode

You can change how the left and right delay signals are panned by modifying the routing of the left and right delay as shown in the figure above. You need to input different

sounds to each channel in order for this parameter to be effective.

Tap1 Level

This parameter sets the output level of Tap1. Setting a different level from Tap2 will add a unique touch to a monotonous delay and feedback.

092: St.ModDly (Stereo Modulation Delay)

This stereo delay uses an LFO to sweep the delay time. The pitch also varies, creating a delay sound which swells and shimmers. You can also control the delay time using a modulation source.

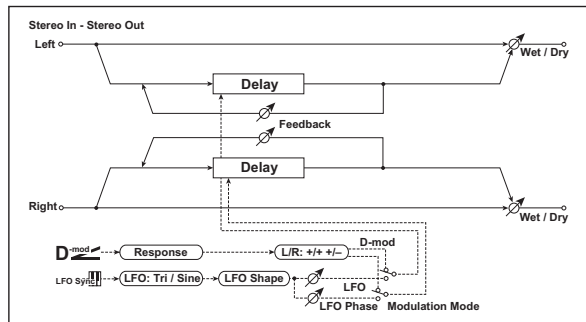

Full parameter	Quick parameter	Value	Explanation
Modulation Mode	Mod Mode	LFO, D-mod	Switches between LFO modulation control and modulation source control
Dmod Modulation		L/R: +/+, L/R: +/-	Reversed L/R control by modulation source p.265
Source	Src	Off...Tempo	Selects the modulation source that controls delay time D-mod
Response		0...30	Sets the rate of response to the modulation source
LFO Dmod Sync		Off, On	Switches LFO reset off/on p.265
LFO Waveform		Triangle, Sine	Selects the LFO Waveform
Source		Off...Tempo	Selects the modulation source that resets the LFO D-mod
Shape		-100...+100	Changes the curvature of the LFO Waveform p.224
LFO Freq [Hz]	LFO [Hz]	0.02...20.00	Sets the speed of the LFO p.225
BPM/MIDI Sync	LFO MIDI Sync	Off, On	When this is on, the LFO speed is set by BPM, Base Note, and Times, instead of Frequency p.223 MIDI
BPM		MIDI, 40.00...300.00	MIDI syncs to the system tempo; 40-300 sets the tempo manually for this individual effect p.223
Base Note			Selects the type of notes that specify the LFO speed p.223
Times		x1...x32	Sets the number of notes that specify the LFO speed p.223
L Delay Delay Time [ms]	L DI[ms]	0.0...259.0	Sets the delay time for the left channel
Feedback	L F.back	-100...+100	Sets the feedback amount of left delay

L Depth	←	0...200	Sets the depth of the left LFO modulation
L LFO Phase [deg]		-180...+180	Sets the phase obtained when the left LFO is reset p.265
R Delay Delay Time [ms]	R DI[ms]	0.0...259.0	Sets the delay time for the right channel
Feedback	R F.back	-100...+100	Sets the feedback amount of right delay
R LFO Phase [deg]		-180...+180	Sets the phase obtained when the right LFO is reset p.265
R Depth	←	0...200	Sets the depth of the right LFO modulation
Wet/Dry	←	-Wet...-1 : 99, Dry, 1 : 99...Wet	Sets the balance between the effect and the dry input p.225 D-mod
Source		Off...Tempo	Selects a modulation source for Wet/Dry
Amount		-100...+100	Sets the modulation amount for Wet/Dry

Dmod Modulation

When the modulation source is used for control, this parameter reverses the left and right modulation direction.

LFO Dmod Sync

Source

L LFO Phase [deg]

R LFO Phase [deg]

If "LFO Sync" is On, the LFO will be reset by the modulation source that is received.

The "Source" parameter sets the modulation source that resets the LFO. For example, you can assign Gate as a modulation source so that the sweep always starts from the specified point.

"L LFO Phase" and "R LFO Phase" set the phase obtained when the left and right LFOs are reset. In this way, you can create changes in pitch sweep for the left and right channels individually.

MIDI The effect is off when a value of the modulation source specified in the "Source" parameter is 63 or smaller, and the effect is on when the value is 64 or higher. The LFO is triggered and reset to the "L LFO Phase" and "R LFO Phase" settings when the value changes from 63 or smaller to 64 or higher.

093: St.DynDly (Stereo Dynamic Delay)

This stereo delay controls the level of delay according to the input signal level. You can use this as a ducking delay that applies delay to the sound only when you play keys at a high velocity or only when the volume level is low.

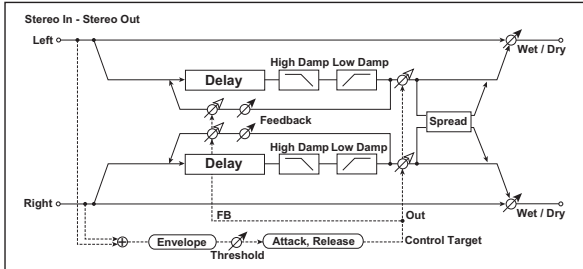

When “Polarity” is negative, Control Target value equals the parameter value if the input level is below the threshold, or is obtained by multiplying the parameter value by the “Offset” value if the level exceeds the threshold. The “Attack” and “Release” parameters specify attack time and release time of delay level control.

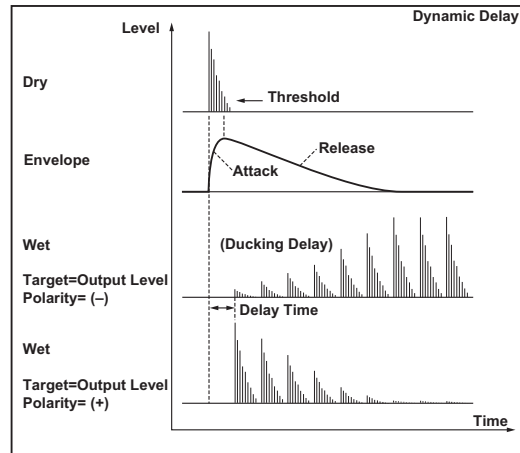

Full parameter	Quick parameter	Value	Explanation
Control Target	Control	None, Out, FB	Selects from no control, output, and feedback p.266
Polarity	←	+, -	Reverses level control p.266
Threshold	←	0...100	Sets the level where the effect is applied p.266
Offset	←	0...100	Sets the offset of level control p.266
Attack		1...100	Sets the attack time of level control p.266
Release		1...100	Sets the release time of level control p.266
L Delay [ms]	L DI[ms]	0.0...274.0	Sets the delay time for the left channel
R Delay [ms]	R DI[ms]	0.0...274.0	Sets the delay time for the right channel
Feedback	←	-100...+100	Sets the feedback amount
High Damp [%]	Hi Damp[%]	0...100	Sets the damping amount in the high range p.264
Low Damp [%]	Lo Damp[%]	0...100	Sets the damping amount in the low range p.264
Spread		-100...+100	Sets the width of the stereo image of the effect sound p.264
Wet/Dry	←	Dry, 1 : 99...99 : 1, Wet	Sets the balance between the effect and the dry input
Source		Off...Tempo	Selects a modulation source for Wet/Dry
Amount		-100...+100	Sets the modulation amount for Wet/Dry

Control Target

This parameter selects no level control, delay output control (effect balance), or feedback amount control.

Polarity

Threshold

Offset

Attack

Release

The “Offset” parameter specifies the value for the “Control Target” parameter (that is set to None), expressed as the ratio relative to the parameter value (the “Wet/Dry” value with “Control Target” = Output Level, or the “Feedback” value with “Control Target” = Feedback).

When “Polarity” is positive, the “Control Target” value is obtained by multiplying the parameter value by the “Offset” value (if the input level is below the threshold), or equals the parameter value if the input level exceeds the threshold.

094: St.PanDly (Stereo Auto Panning Delay)

This stereo delay effect pans the delay sound left and right using the LFO.

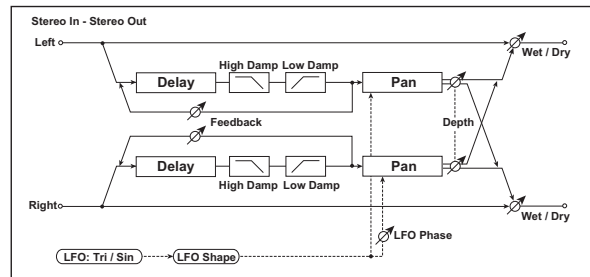

Full parameter	Quick parameter	Value	Explanation
High Damp [%]	Hi Damp[%]	0...100	Sets the damping amount in the high range p.264
Low Damp [%]	Lo Damp[%]	0...100	Sets the damping amount in the low range p.264
Pan Depth	Pan Depth	0...100	Sets the panning width
Source		Off...Tempo	Selects the modulation source for the panning width
Amount		-100...+100	Set the modulation amount of the panning width
L Delay Delay Time [ms]	L DI[ms]	0.0...274.0	Sets the delay time for the left channel
Feedback	L F.back	-100...+100	Sets the feedback amount for the left channel
R Delay Delay Time [ms]	R DI[ms]	0.0...274.0	Sets the delay time for the right channel
Feedback	R F.back	-100...+100	Sets the feedback amount for the right channel
LFO Waveform		Triangle, Sine	Selects the LFO waveform
Shape		-100...+100	Changes the curvature of the LFO waveform p.224

Phase [deg]		-180...+180	Sets the LFO phase difference between the left and right p.238	
Panning Freq [Hz]	Pan[Hz]	0.02...20.00	Sets the panning speed	
BPM/MIDI Sync	LFO MIDI Sync	Off, On	Switches between using the frequency of the panning speed and using the tempo and notes p.223	
BPM		MIDI, 40.00...300.00	MIDI syncs to the system tempo; 40-300 sets the tempo manually for this individual effect p.223	
Base Note			Selects the type of notes to specify the delay time for the panning speed p.223	
Times		x1...x32	Sets the number of notes to specify the delay time for the panning speed p.223	
Wet/Dry	←	Dry, 1 : 99... 99 : 1, Wet	Sets the balance between the effect and the dry input	
Source		Off...Tempo	Selects a modulation source for Wet/Dry	
Amount		-100...+100	Sets the modulation amount for Wet/Dry	

095: Tape Echo

This effect simulates a tape echo unit with three playback heads. The distortion and tonal change typical of magnetic tape are also reproduced.

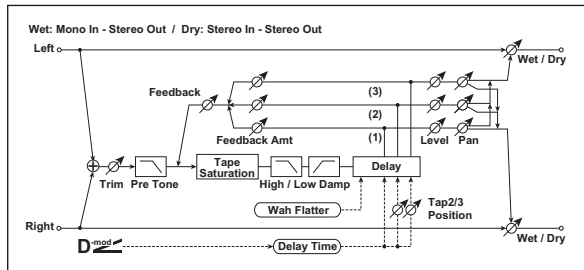

Full parameter	Quick parameter	Value	Explanation	
Input Trim		0...100	Sets the input gain	
Pre Tone		0...100	Sets the tone of the input	
Wow Flutter [Hz]		0.02...1.00	Sets the frequency at which pitch variation will occur	
Depth		0...100	Sets the depth of pitch variation	
High Damp [%]	Hi Damp[%]	0...100	Sets the damping amount in the high range	
Low Damp [%]	Lo Damp[%]	0...100	Sets the damping amount in the low range	
Saturation	←	0...100	Sets the distortion amount	
Tap1 Delay [ms]	Dly-T1[ms]	0...539	Sets the delay time (tap1) p.267	
Source		Off...Tempo	Selects the modulation source of the delay time p.267	
Amount		-2700... +2700	Sets the modulation amount of delay time p.267	
Level		0...100	Sets the Tap1 output level	
Pan		L, 1...99, R	Sets the stereo image of tap1	
Feedback Amount		-100...+100	Sets the Tap1 feedback amount p.267	

Tap2 Position [%]		0...100	Sets the position of Tap 2 relative to the Tap 1 delay time the depth of pitch variation p.267	
Level		0...100	Sets the Tap2 output level	
Pan		L, 1...99, R	Sets the stereo image of tap2	
Feedback Amount		-100...+100	Sets the Tap2 feedback amount p.267	
Tap3 Position [%]		0...100	Sets the position of Tap 3 relative to the Tap 1 delay time the depth of pitch variation p.267	
Level		0...100	Sets the Tap3 output level	
Pan		L, 1...99, R	Sets the stereo image of tap3	
Feedback Amount		-100...+100	Sets the Tap3 feedback amount p.267	
Feedback Level	Feedback	0...100	Sets the amount of feedback for Taps 1, 2, and 3 p.267	
Source		Off...Tempo	Selects the modulation source of feedback amount	
Amount		-100...+100	Sets the feedback amount	
Wet/Dry	←	Dry, 1 : 99...99 : 1, Wet	Sets the balance between the effect and the dry input	
Source		Off...Tempo	Selects a modulation source for Wet/Dry	
Amount		-100...+100	Sets the modulation amount for Wet/Dry	

Tap1 Delay [ms]

Source

Amount

Tap2 Position [%]

Tap3 Position [%]

The delay time for Tap 2 and 3 is specified as a proportion (%) relative to "Delay (Tap1)." Even if you use dynamic modulation to control "Delay (Tap1)," Tap 2 and 3 will change at the same proportion.

Feedback Amount

Feedback Level

The feedback output from Tap 1, 2, and 3 is mixed according to the "Feedback Amount," and then the final amount of feedback is specified by "Feedback Level."

096: Echo Plus

This models a famous analog tape echo unit. On the original device, “echo” was created by a playback head, and the “delay time” was specified by adjusting the speed of the motor. The warmth and subtlety of the echoes it generated made this “lo-fi” unit a favorite with many pro musicians.

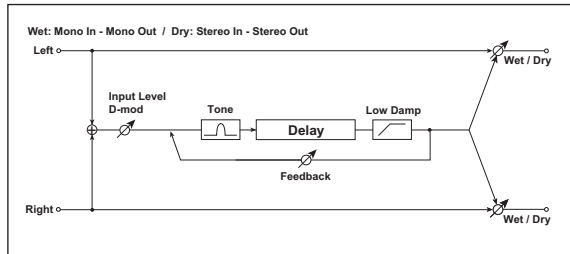

Full parameter	Quick parameter	Value	Explanation	
Time [ms]	Dly-T1[ms]	0...539	Sets the delay time	
Feedback	←	0...100	Sets the amount of feedback	
Tone		1...100	Sets the tone of the delay sound	
Low Damp [%]	Lo Damp[%]	0...100	Sets the damping amount in the low range p.264	
Input Lvl Dmod [%]		-100...+100	Sets the modulation amount of the input level p.258	D-mod
Source		Off...Tempo	Selects the modulation source for the input level p.258	
Wet/Dry	←	Dry, 1 : 99... 99 : 1, Wet	Sets the balance between the effect and the dry input	D-mod
Source		Off...Tempo	Selects a modulation source for Wet/Dry	
Amount		-100...+100	Sets the modulation amount for Wet/Dry	

097: Auto Reverse

This effect records the input signal and automatically plays it in reverse (the effect is similar to a tape reverse sound).

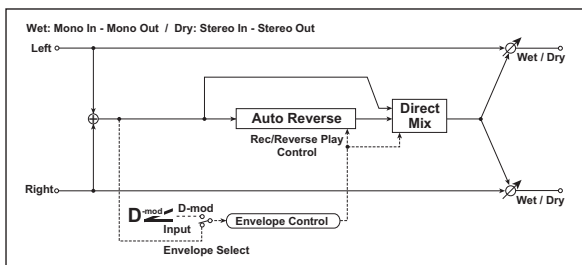

Full parameter	Quick parameter	Value	Explanation	
Rec Mode	←	Single, Multi	Sets the recording mode p.268	
Reverse Time [ms]	Revers	20...2640	Sets the maximum duration of the reverse playback p.268	
Envelope	Env Sel	D-mod, Input	Selects whether the start and end of recording is controlled via the modulation source or the input signal level p.268	

Source	Src	Off...Tempo	Selects the modulation source that controls recording when Envelope Select is set to D-mod p.268	D-mod
Threshold	←	0...100	Sets the recording start level when Envelope Select is set to Input p.268	
Response		0...100	Sets the speed of the response to the end of recording p.268	
Direct Mix	Direct	Always On, Always Off, Cross Fade	Selects how a dry sound is mixed p.269	
Wet/Dry	←	Dry, 1 : 99... 99 : 1, Wet	Sets the balance between the effect and the dry input	D-mod
Source		Off...Tempo	Selects a modulation source for Wet/Dry	
Amount		-100...+100	Sets the modulation amount for Wet/Dry	

Rec Mode

Reverse Time [ms]

When “Rec Mode” is set to Single, you can set up to 2,640msec for “Reverse Time.” If recording starts during the reverse playback, the playback will be interrupted.

When “Rec Mode” is set to Multi, you can make another recording during the reverse playback. However, the maximum Reverse Time is limited to 1,320msec.

If you wish to record a phrase or rhythm pattern, set “Rec Mode” to Single. If you record only one note, set “Rec Mode” to Multi.

The “Reverse Time” parameter specifies the maximum duration of the reverse playback. The part in excess of this limit will not be played in reverse. If you wish to add short pieces of the reverse playback of single notes, make the “Reverse Time” shorter.

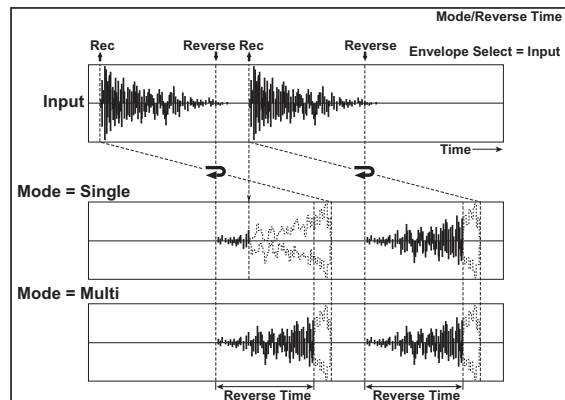

Envelope

Source

Threshold

These parameters select the source to control the start and end of recording.

When “Envelope” is set to D-mod, the input signal will be recorded only when the value of the modulation source selected by the Source parameter is 64 or higher.

When “Envelope” is set to Input, the input signal will be recorded only when its level exceeds the Threshold level.

When recording is completed, reverse playback starts immediately.

Response

This parameter enables you to set the speed of the response to the end of recording. Set a smaller value when you are recording a phrase or rhythm pattern, and set a higher value if you are recording only one note.

Direct Mix

With Always On, a dry sound is usually output. With Always Off, dry sounds are not output. With Cross Fade, a dry sound is usually output, and it is muted only when scratching.

Set Wet/Dry to Wet to use this parameter effectively.

098: SeqDlyBPM (Sequence BPM Delay)

This four-tap delay enables you to select a tempo and rhythm pattern to set up each tap.

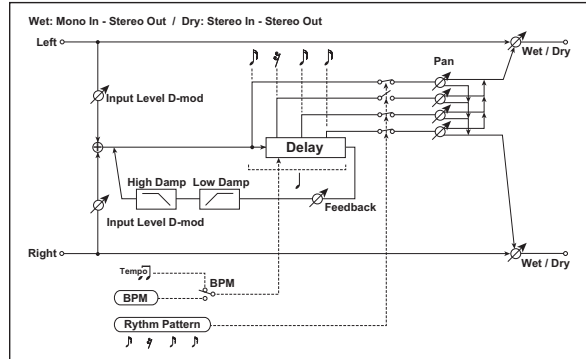

Full parameter	Quick parameter	Value	Explanation	
Input Level Dmod [%]		-100...+100	Sets the modulation amount of the input level p.258	D ^{mod}
Source		Off...Tempo	Selects the modulation source for the input level p.258	
BPM	←	MIDI, 40.00... 300.00	MIDI syncs to the system tempo; 40-300 sets the tempo manually for this individual effect p.269	A ^{sync}
Rhythm	←	♪♪♪♪♪	Selects a rhythm pattern p.269	A ^{sync}
Tap1 Pan	←	L, 1...99, R	Sets the panning of Tap1	
Tap2 Pan	←	L, 1...99, R	Sets the panning of Tap2	
Tap3 Pan	←	L, 1...99, R	Sets the panning of Tap3	
Tap4 Pan	←	L, 1...99, R	Sets the panning of Tap4	
Feedback	←	-100...+100	Sets the feedback amount	D ^{mod}
Source		Off...Tempo	Selects the modulation source of feedback amount	
Amount		-100...+100	Sets the feedback amount	
High Damp [%]	Hi Damp[%]	0...100	Sets the damping amount in the high range p.264	
Low Damp [%]	Lo Damp[%]	0...100	Sets the damping amount in the low range p.264	
Wet/Dry	←	Dry, 1 : 99... 99 : 1, Wet	Sets the balance between the effect and the dry input	D ^{mod}
Source		Off...Tempo	Selects a modulation source for Wet/Dry	
Amount		-100...+100	Sets the modulation amount for Wet/Dry	

BPM

Rhythm

With the tempo specified by the "BPM" parameter (or the MIDI Clock tempo if "BPM" is set to MIDI), the length of one beat equals the feedback delay time, and the interval

between taps becomes equal. Selecting a rhythm pattern will automatically turn the tap outputs on and off. When "BPM" is set to MIDI, the lower limit of the "BPM" is 44.

099: LCR BPM (L/C/R BPM Delay)

The L/C/R delay enables you to match the delay time with the song tempo. You can also synchronize the delay time with the arpeggiator or sequencer. If you program the tempo before performance, you can achieve a delay effect that synchronizes with the song in real-time. Delay time is set by notes.

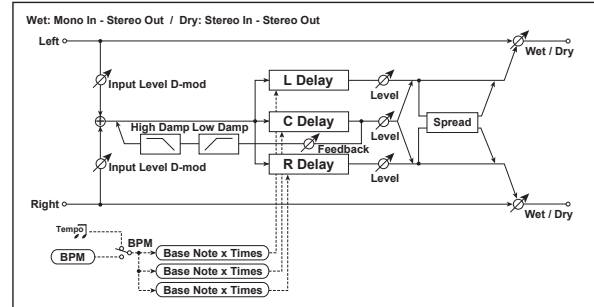

Full parameter	Quick parameter	Value	Explanation	
Input Lvl Dmod [%]		-100...+100	Sets the modulation amount of the input level p.258	D ^{mod}
Source		Off...Tempo	Selects the modulation source for the input level p.258	
Time Over?	←	---, OVER!	Displays an error message when the delay time exceeds the upper limit p.270	
BPM		MIDI, 40.00... 300.00	MIDI syncs to the system tempo; 40-300 sets the tempo manually for this individual effect p.223	A ^{sync}
High Damp [%]	Hi Damp[%]	0...100	Sets the damping amount in the high range p.264	
Low Damp [%]	Lo Damp[%]	0...100	Sets the damping amount in the low range p.264	
Spread		0...50	Sets the width of the stereo image of the effect sound p.264	
L Delay Base Note	L Base Note	♪♪♪	Selects the type of notes to specify the delay time for TapL p.270	A ^{sync}
Times	L Times	x1...x32	Sets the number of notes to specify the delay time for TapL p.270	
Level	L Level	0...50	Sets the output level of TapL	
C Delay Base Note	C Base Note	♪♪♪	Selects the type of notes to specify the delay time for TapC p.270	A ^{sync}
Times	C Times	x1...x32	Sets the number of notes to specify the delay time for TapC p.270	
Level	C Level	0...50	Sets the output level of TapC	
C Delay Feedback	Feedback	-100...+100	Sets the feedback amount of TapC	D ^{mod}
R Delay Base Note	R Base Note	♪♪♪	Selects the type of notes to specify the delay time for TapR p.270	A ^{sync}
Times	R Times	x1...x32	Sets the number of notes to specify the delay time for TapR p.270	

Level	R Level	0...50	Sets the output level of TapR	
Source		Off...Tempo	Selects the modulation source for the TapC feedback	
Amount		-100...+100	Sets the modulation amount of the TapC feedback	
Wet/Dry	←	Dry, 1 : 99... 99 : 1, Wet	Sets the balance between the effect and the dry input	D ^{mod}
Source		Off...Tempo	Selects a modulation source for Wet/Dry	
Amount		-100...+100	Sets the modulation amount for Wet/Dry	

BPM

Delay Base Note Times

The delay time is the duration of Times number of Delay Base Note note values at the BPM tempo (or if BPM is set to MIDI, the tempo determined by MIDI Clock).

Time Over?

You can set the delay time up to 5,460msec. If the delay time exceeds this limit, the error message "OVER!" appears in the display. Set the delay time parameters so that this message will not appear. "Time Over?" is only a display parameter.

100: St.DlyBPM (Stereo BPM Delay)

This stereo delay enables you to set the delay time to match the song tempo.

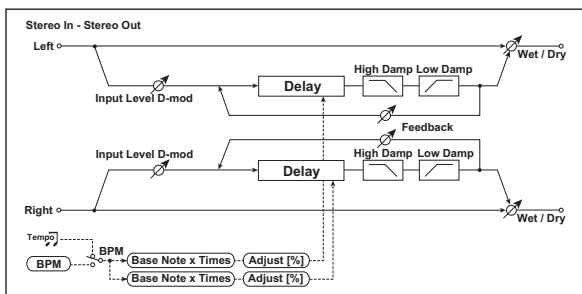

Full parameter	Quick parameter	Value	Explanation	
Input Lvl Dmod [%]		-100...+100	Sets the modulation amount of the input level p.258	D ^{mod}
Source		Off...Tempo	Selects the modulation source for the input level p.258	
BPM	←	MIDI, 40.00... 300.00	MIDI syncs to the system tempo; 40-300 sets the tempo manually for this individual effect p.270	BPM
High Damp [%]	Hi Damp[%]	0...100	Sets the damping amount in the high range p.264	
Low Damp [%]	Lo Damp[%]	0...100	Sets the damping amount in the low range p.264	
L Delay Time Over?	T.OverL?	---, OVER!	Display the error message if the left channel delay time exceeds the upper limit p.270	
Base Note	L Base Note	♪...♪ ₃	Selects the type of notes to specify the left channel delay time p.270	BPM
Times	L Time	x1...x32	Sets the number of notes to specify the left channel delay time p.270	
Adjust [%]		-2.50...+2.50	Fine-adjust the left channel delay time	

Feedback	L F.back	-100...+100	Sets the feedback amount for the left channel	D ^{mod}
Source		Off...Tempo	Selects the modulation source of feedback amount	
Amount		-100...+100	Sets the modulation amount of the left channel feedback	
R Delay Time Over?	T.OverR?	---, OVER!	Display the error message if the right channel delay time exceeds the upper limit p.270	
Base Note	R Base Note	♪...♪ ₃	Selects the type of notes to specify the right channel delay time p.270	BPM
Times	R Time	x1...x32	Sets the number of notes to specify the right channel delay time p.270	
Adjust [%]		-2.50...+2.50	Fine-adjust the right channel delay time	
Feedback	R F.back	-100...+100	Sets the feedback amount for the right channel	
Amount		-100...+100	Sets the modulation amount of the right channel feedback	D ^{mod}
Wet/Dry	←	Dry, 1 : 99... 99 : 1, Wet	Sets the balance between the effect and the dry input	D ^{mod}
Source		Off...Tempo	Selects a modulation source for Wet/Dry	
Amount		-100...+100	Sets the modulation amount for Wet/Dry	

Time Over? L, R





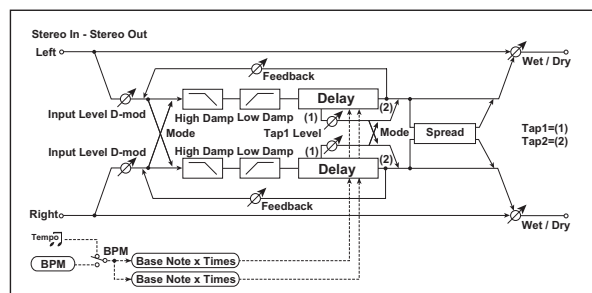

You can set the delay time up to 2,730msec. If the delay time exceeds this limit, the error message "OVER!" appears in the display. Set the delay time parameters so that this message will not appear. "Time Over?" is only a display parameter.

101: St.MtdBPM (Stereo BPM Multitap Delay)

This is a stereo multi-tapped delay that lets you set the delay time to match the tempo of the song.









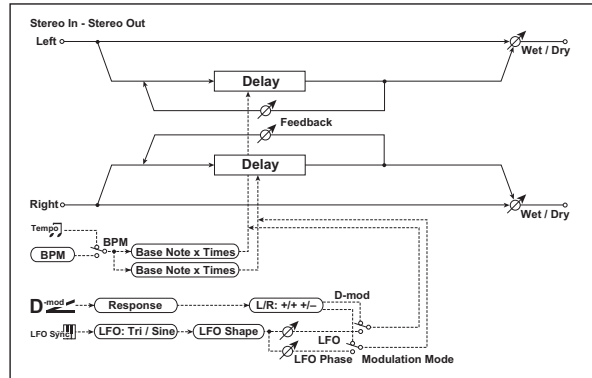

Full parameter	Quick parameter	Value	Explanation	
Input Lvl Dmod [%]		-100...+100	Sets the modulation amount of the input level p.258	D ^{mod}
Source		Off...Tempo	Selects the modulation source for the input level p.258	
Mode	←	Normal, Cross Feedback, Cross Pan1, Cross Pan2	Switches the left and right delay routing p.264	
BPM	←	MIDI, 40.00... 300.00	MIDI syncs to the system tempo; 40-300 sets the tempo manually for this individual effect p.270	BPM

High Damp [%]	Hi Damp[%]	0...100	Sets the damping amount in the high range p.264	
Low Damp [%]	Lo Damp[%]	0...100	Sets the damping amount in the low range p.264	
Tap1 Time Over?	T.OverL?	---, OVER!	Displays an error message when the delay time for Tap1 exceeds the upper limit p.270	
Base Note	T1 BaseNote		Selects the type of notes to specify the delay time for Tap1 p.270	
Times	T1 Times	x1...x32	Sets the number of notes to specify the delay time for Tap1 p.270	
Tap1 Level	←	0...100	Sets the Tap1 output level p.265	
Tap2 Time Over?	T.OverR?	---, OVER!	Displays an error message when the delay time for Tap2 exceeds the upper limit p.270	
Base Note	T2 BaseNote		Selects the type of notes to specify the delay time for Tap2 p.270	
Times	T2 Times	x1...x32	Sets the number of notes to specify the delay time for Tap2 p.270	
Feedback (Tap2)	←	-100...+100	Sets the Tap2 feedback amount 	
Source		Off...Tempo	Selects the modulation source of the Tap2 feedback amount	
Amount		-100...+100	Sets the modulation amount of the Tap2 feedback amount	
Spread		-100...+100	Sets the width of the stereo image of the effect sound p.264 	
Source		Off...Tempo	Selects the modulation source of the effect sound's stereo image width	
Amount		-100...+100	Sets the modulation amount of the effect sound's stereo image width	
Wet/Dry	←	Dry, 1 : 99... 99 : 1, Wet	Sets the balance between the effect and the dry input 	
Source		Off...Tempo	Selects a modulation source for Wet/Dry	
Amount		-100...+100	Sets the modulation amount for Wet/Dry	

102: St.ModBPM (Stereo BPM Modulation Delay)

This is a stereo modulation delay that lets you synchronize the delay time to the tempo of the song.



Full parameter	Quick parameter	Value	Explanation	
Delay BPM	←	MIDI, 40.00... 300.00	MIDI syncs to the system tempo; 40-300 sets the tempo manually for this individual effect p.270	
Modulation Mode	Mode Mode	LFO, D-mod	Switches between LFO modulation control and modulation source control	
Dmod Modulation		L/R: +/+ , L/R: +/-	Reversed L/R control by modulation source p.265	
Source	Src	Off...Tempo	Selects the modulation source that controls delay time 	
Response		0...30	Sets the rate of response to the modulation source	
LFO Dmod Sync		Off, On	Switches LFO reset off/on p.265	
LFO Waveform		Triangle, Sine	Selects the LFO Waveform	
LFO Freq [Hz]	LFO [Hz]	0.02...20.00	Sets the speed of the LFO p.225	
Shape		-100...+100	Changes the curvature of the LFO Waveform p.224	
Source		Off...Tempo	Selects the modulation source that resets the LFO 	
L Delay Time Over?	T.OverL?	---, OVER!	Display the error message if the left channel delay time exceeds the upper limit p.272	
Base Note	L Base Note		Selects the type of notes to specify the left channel delay time p.270	
Times	L Times	x1...x32	Sets the number of notes to specify the left channel delay time p.270	
Feedback	L F.back	-100...+100	Sets the feedback amount of left delay	
Depth	L Depth	0...200	Sets the depth of the left LFO modulation	
LFO Phase [deg]		-180...+180	Sets the phase obtained when the left LFO is reset p.265	
R Delay Time Over?	T.OverR?	---, OVER!	Display the error message if the right channel delay time exceeds the upper limit p.272	
R Delay Base Note	R Base Note		Selects the type of notes to specify the right channel delay time p.270	

Times	R Times	x1...x32	Sets the number of notes to specify the right channel delay time p.270	
Feedback	R F.back	-100...+100	Sets the feedback amount of right delay	
R LFO Phase [deg]		-180...+180	Sets the phase obtained when the right LFO is reset p.265	
Depth	R Depth	0...200	Sets the depth of the right LFO modulation	
BPM/MIDI Sync	LFO MIDI Sync	Off, On	When this is on, the LFO speed is set by BPM, Base Note, and Times, instead of Frequency p.223	
BPM		MIDI, 40.00... 300.00	MIDI syncs to the system tempo; 40-300 sets the tempo manually for this individual effect p.223	
Base Note			Selects the type of notes that specify the LFO speed p.223	
Times		x1...x32	Sets the number of notes that specify the LFO speed p.223	
Wet/Dry	←	-Wet... -1 : 99, Dry, 1 : 99...Wet	Sets the balance between the effect and the dry input p.225	
Source		Off...Tempo	Selects a modulation source for Wet/Dry	
Amount		-100...+100	Sets the modulation amount for Wet/Dry	

Time Over? L, R

You can set the delay time up to 2,550msec. If the delay time exceeds this limit, the error message "OVER!" appears in the display. Set the delay time parameters so that this message will not appear. "Time Over?" is only a display parameter.

103: St.ApdBPM (Stereo BPM Auto Panning Delay)

This stereo auto panning delay enables you to set the delay time to match the song tempo.

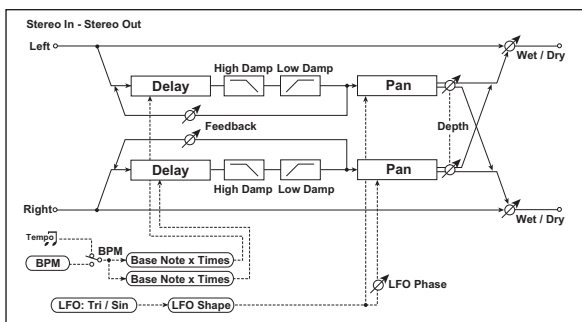

Full parameter	Quick parameter	Value	Explanation	
Delay BPM	←	MIDI, 40.00... 300.00	MIDI syncs to the system tempo; 40-300 sets the tempo manually for this individual effect p.270	
High Damp [%]	Hi Damp[%]	0...100	Sets the damping amount in the high range p.264	
Low Damp [%]	Lo Damp[%]	0...100	Sets the damping amount in the low range p.264	
Pan Depth	←	0...100	Sets the panning width	
Source		Off...Tempo	Selects the modulation source for the panning width	

Amount		-100...+100	Set the modulation amount of the panning width	
L Delay Time Over?	T.OverL?	---, OVER!	Display the error message if the left channel delay time exceeds the upper limit p.270	
Base Note	L Base Note		Selects the type of notes to specify the left channel delay time p.270	
Times	L Times	x1...x32	Sets the number of notes to specify the left channel delay time p.270	
Feedback	L F.back	-100...+100	Sets the feedback amount for the left channel	
R Delay Time Over?	T.OverR?	---, OVER!	Display the error message if the right channel delay time exceeds the upper limit p.270	
Base Note	R Base Note		Selects the type of notes to specify the right channel delay time p.270	
Times	R Times	x1...x32	Sets the number of notes to specify the right channel delay time p.270	
Feedback	R F.back	-100...+100	Sets the feedback amount for the right channel	
LFO Waveform		Triangle, Sine	Selects the LFO Waveform	
Shape		-100...+100	Changes the curvature of the LFO Waveform p.224	
Phase [deg]		-180...+180	Sets the LFO phase difference between the left and right p.237	
Panning Freq [Hz]	Pan [Hz]	0.02...20.00	Sets the panning speed p.223	
BPM/MIDI Sync	Pan MDI Sync	Off, On	When this is on, the pan LFO speed is set by BPM, Base Note, and Times, instead of Frequency p.223	
BPM		MIDI, 40.00... 300.00	MIDI syncs to the system tempo; 40-300 sets the tempo manually for this individual effect p.223	
Base Note			Selects the type of notes to specify the delay time for the panning speed p.223	
Times		x1...x32	Sets the number of notes to specify the delay time for the panning speed p.223	
Wet/Dry	←	Dry, 1 : 99... 99 : 1, Wet	Sets the balance between the effect and the dry input	
Source		Off...Tempo	Selects a modulation source for Wet/Dry	
Amount		-100...+100	Sets the modulation amount for Wet/Dry	

104: TapeE BPM (Tape Echo BPM)

This is a tape echo that lets you synchronize the delay time to the tempo of the song.

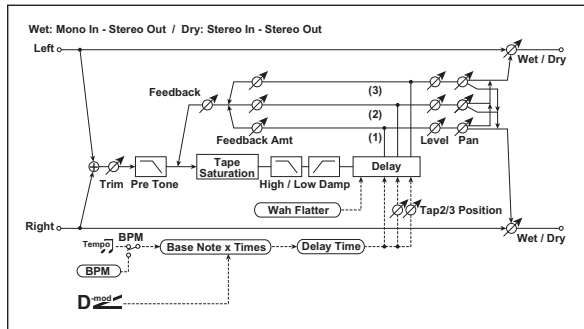

Full parameter	Quick parameter	Value	Explanation	
Input Trim		0...100	Sets the input gain	
Pre Tone		0...100	Sets the tone of the input	
Wow Flutter [Hz]		0.02...1.00	Sets the frequency at which pitch variation will occur	
Depth		0...100	Sets the depth of pitch variation	
High Damp [%]	Hi Damp[%]	0...100	Sets the damping amount in the high range	
Low Damp [%]	Lo Damp[%]	0...100	Sets the damping amount in the low range	
Saturation	←	0...100	Sets the distortion amount	
Time Over?	←	---, OVER!	Displays an error message when the delay time exceeds the upper limit p.273	
Delay BPM	BPM	MIDI, 40.00...300.00	MIDI syncs to the system tempo; 40–300 sets the tempo manually for this individual effect p.270	
Tap1 Delay Note	T1 BaseNote		Selects the type of notes to specify the delay time (tap1) p.270, p.273	
Times	T1 Times	x1...x32	Sets the number of notes to specify the delay time (tap1) p.270, p.273	
Source		Off...Tempo	Selects the modulation source of the delay time p.273	
Dmod Max Note			Selects the note value used to specify the delay time when the modulation is at maximum p.273	
Times		x1...x32	Specifies the number of notes used to specify the delay time when the modulation is at maximum p.273	
Level		0...100	Sets the Tap1 output level	
Pan		L, 1...99, R	Sets the stereo image of tap1	
Feedback Amount		-100...+100	Sets the Tap1 feedback amount p.267	
Tap2 Position [%]		0...100	Sets the position of Tap 2 relative to the Tap 1 delay time the depth of pitch variation p.267	
Level		0...100	Sets the Tap2 output level	
Pan		L, 1...99, R	Sets the stereo image of tap2	
Feedback Amount		-100...+100	Sets the Tap2 feedback amount p.267	

Tap3 Position [%]		0...100	Sets the position of Tap 3 relative to the Tap 1 delay time the depth of pitch variation p.267	
Level		0...100	Sets the Tap3 output level	
Pan		L, 1...99, R	Sets the stereo image of tap3	
Feedback Amount		-100...+100	Sets the Tap3 feedback amount p.267	
Feedback Level	Feedback	0...100	Sets the amount of feedback for Taps 1, 2, and 3 p.267	
Source		Off...Tempo	Selects the modulation source of feedback amount	
Amount		-100...+100	Sets the depth by which feedback amount will be modulated	
Wet/Dry	←	Dry, 1 : 99... 99 : 1, Wet	Sets the balance between the effect and the dry input	
Source		Off...Tempo	Selects a modulation source for Wet/Dry	
Amount		-100...+100	Sets the modulation amount for Wet/Dry	

Tap1 Delay Note

Times

Source

Tap1 Dmod Note

Times

If "Source" is Off or the selected modulation is at 0, the delay time will be the length specified by "Tap1 Delay Note" and "Times."

If "Source" is other than Off, the delay time will change so that it will be as specified by "Tap1 Dmod Note" and "Times" when the maximum modulation is reached.

Time Over?

You can set the delay time up to 5,400msec. If the delay time exceeds this limit, the error message "OVER!" appears in the display. Set the delay time parameters so that this message will not appear. "Time Over?" is only a display parameter.

105: Rev.Hall (Reverb Hall)

This hall-type reverb simulates the reverberation of mid-size concert halls or ensemble halls.

106: Rev.Plate (Reverb Plate)

This plate reverb simulates warm (dense) reverberation.

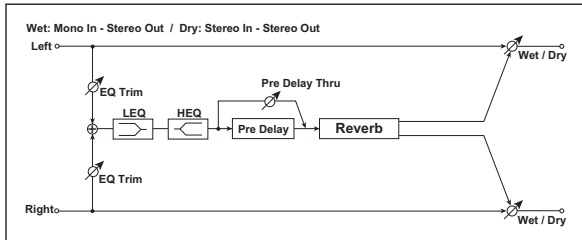

Full parameter	Quick parameter	Value	Explanation	
Pre EQ Trim	PreEQ Trim	0...100	Sets the EQ input level	
Pre LEQ Fc		Low, Mid-Low	Selects the cutoff frequency (low or mid-low) of the low-range equalizer	
LEQ Gain [dB]	LEQ [dB]	-15.0...+15.0	Sets the gain of Low EQ	
Pre HEQ Fc		High, Mid-High	Selects the cutoff frequency (high or mid-high) of the high-range equalizer	
Pre HEQ Gain [dB]	HEQ [dB]	-15.0...+15.0	Sets the gain of High EQ	
Reverb Time [s]	Times[s]	0.1...10.0	Sets the reverberation time	
High Damp [%]	Hi Damp[%]	0...100	Sets the damping amount in the high range	
Pre Delay [msec]		0...200	Sets the delay time from the dry sound <small>p.274</small>	
Pre Delay Thru [%]		0...100	Sets the mix ratio of non-delay sound <small>p.274</small>	
Wet/Dry	←	Dry, 1 : 99... 99 : 1, Wet	Sets the balance between the effect and the dry input	$D^{mod} \leq$
Source		Off...Tempo	Selects a modulation source for Wet/Dry	
Amount		-100...+100	Sets the modulation amount for Wet/Dry	

Pre Delay Thru [%]

“Pre Delay Thru” lets you accentuate the attack by mixing in sound that does not pass through the delay.

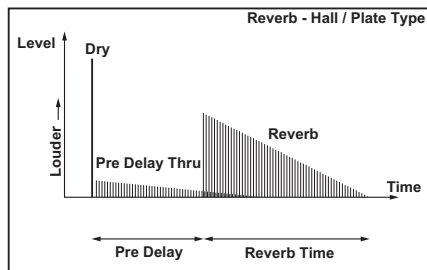

107: Rev.Room1 (Reverb Room)

This room-type reverb emphasizes the early reflections that make the sound tighter. Changing the balance between the early reflections and reverb sound allows you to simulate nuances, such as the type of walls of a room.

108: Rev.Room2 (Reverb Room)

This room-type reverb emphasizes the early reflections that make the sound brighter.

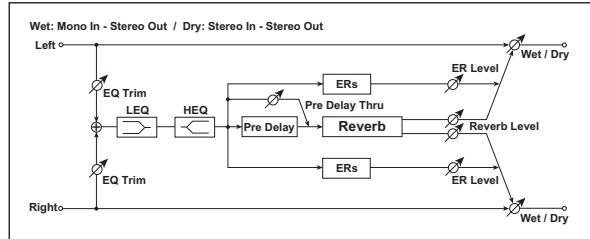

Full parameter	Quick parameter	Value	Explanation	
EQ Trim	←	0...100	Sets the EQ input level	
Pre LEQ Fc		Low, Mid-Low	Selects the cutoff frequency (low or mid-low) of the low-range equalizer	
LEQ Gain [dB]	LEQ [dB]	-15.0...+15.0	Sets the gain of Low EQ	
Pre HEQ Fc		High, Mid-High	Selects the cutoff frequency (high or mid-high) of the high-range equalizer	
HEQ Gain [dB]	HEQ [dB]	-15.0...+15.0	Sets the gain of High EQ	
Reverb Time [sec]	Times [s]	0.1...3.0	Sets the reverberation time	
High Damp [%]	Hi Damp[%]	0...100	Sets the damping amount in the high range	
Pre Delay [msec]	PreDly[ms]	0...200	Sets the delay time from the dry sound <small>p.274</small>	
Pre Delay Thru [%]	preDlyThru	0...100	Sets the mix ratio of non-delay sound <small>p.274</small>	
ER Level	←	0...100	Sets the level of early reflections <small>p.274</small>	
Reverb Level	Rev Level	0...100	Sets the reverberation level <small>p.274</small>	
Wet/Dry	←	Dry, 1 : 99... 99 : 1, Wet	Sets the balance between the effect and the dry input	$D^{mod} \leq$
Source		Off...Tempo	Selects a modulation source for Wet/Dry	
Amount		-100...+100	Sets the modulation amount for Wet/Dry	

Pre Delay

Pre Delay Thru [%]

“Pre Delay” specifies the delay time for the sound that is input to the reverb. This controls the spaciousness. “Pre Delay Thru” lets you accentuate the attack by mixing in sound that does not pass through this delay.

ER Level

Reverb Level

These parameters set the early reflection level and reverb level. Changing these parameter values will allow you to simulate the type of walls in the room. That is, a larger “ER Level” simulates a hard wall, and a larger “Reverb Level” simulates a soft wall.

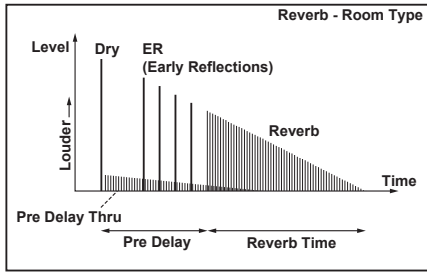

109: R2.Spring (Reverb2 Spring)

The R2-type reverbs R2.Spring–R2.Room have a different sonic character than Rev.Hall–Rev.Room2. They model the spring reverb systems that are built into some amps.

110: R2.Hall (Reverb2 Hall)

This models the reverberation of a concert hall that includes numerous echo components.

111: R2.Plate (Reverb2 Plate)

This models a type of reverb unit that vibrates a metal plate rather than springs. The reverb time is relatively short. Because the reverberation has a fast attack, it is suitable for percussive playing.

112: R2.Room (Reverb2 Room)

This models the reverberation of a typical room that includes numerous early reflections.

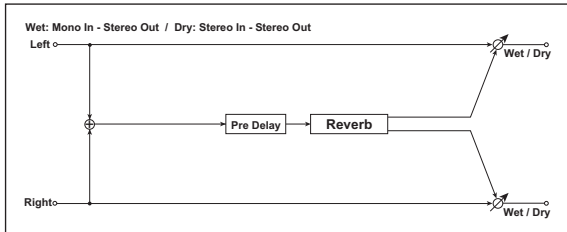

Full parameter	Quick parameter	Value	Explanation
Time [sec]	←	0...100	Sets the reverberation time p.275
High Damp [%]	Hi Damp[%]	0...100	Sets the damping amount in the high range
Low Damp [%]	Lo Damp[%]	0...100	Sets the damping amount in the low range
Pre Delay [msec]	PreDly [ms]	0...200	Sets the delay time from the dry sound p.275
Wet/Dry	←	Dry, 1 : 99... 99 : 1, Wet	Sets the balance between the effect and the dry input
Source		Off...Tempo	Selects a modulation source for Wet/Dry
Amount		-100...+100	Sets the modulation amount for Wet/Dry

Time

In these reverbs, "Time" is not expressed in seconds, but instead is a value from 1 to 100. A value of 1 produces the shortest reverb, and 100 provides the longest reverb.

113: Early Reflections

This effect is only the early reflection part of a reverberation sound, and adds presence to the sound. You can select one of the four decay curves.

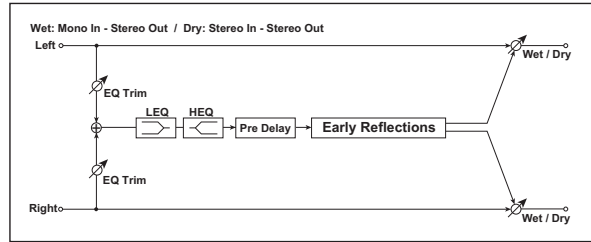

Full parameter	Quick parameter	Value	Explanation
Pre EQ Trim	PreEQ Trim	0...100	Sets the input level of EQ applied to the effect sound
Pre LEQ Fc		Low, Mid-Low	Selects the cutoff frequency (low or mid-low) of the low-range equalizer
LEQ Gain [dB]	LEQ [dB]	-15.0...+15.0	Sets the gain of the Low EQ
Pre HEQ Fc		High, Mid-High	Selects the cutoff frequency (high or mid-high) of the high-range equalizer
HEQ Gain [dB]	HEQ [dB]	-15.0...+15.0	Sets the gain of the High EQ
Type	←	Sharp, Loose, Modulated, Reverse	Selects the decay curve for the early reflection p.275
ER Time [ms]	Times[ms]	10...800	Sets the time length of early reflection
Pre Delay [ms]	PreDly[ms]	0...200	Sets the time taken from the original sound to the first early reflection
Wet/Dry	←	Dry, 1 : 99... 99 : 1, Wet	Sets the balance between the effect and the dry input
Source		Off...Tempo	Selects a modulation source for Wet/Dry
Amount		-100...+100	Sets the modulation amount for Wet/Dry

Type

This parameter selects the decay curve for the early reflection.

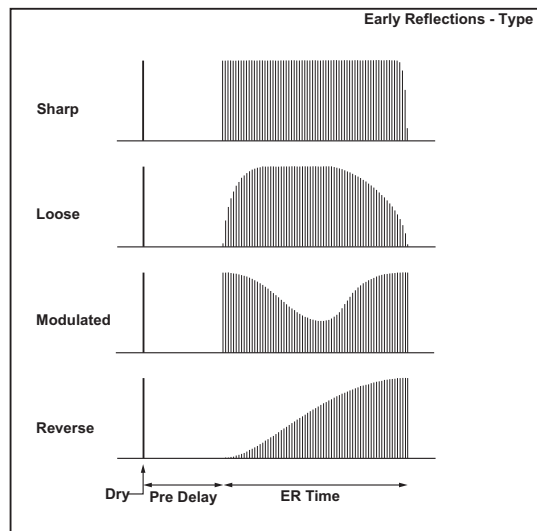

114: P4EQ - MDly (Parametric 4-Band EQ - Multitap Delay)

This effect combines a mono four-band parametric equalizer and a multitap delay.

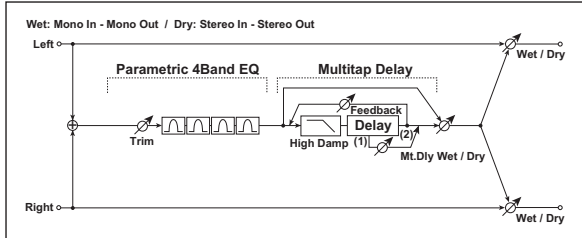

Full parameter	Quick parameter	Value	Explanation
Parametric 4-Band EQ			
Trim	E Trim	0...100	Sets the parametric EQ input level
Band1 Cutoff [Hz]	E1 F[Hz]	20...1.00k	Sets the center frequency of Band 1
Band1 Q	E1 Q	0.5...10.0	Sets the bandwidth of Band 1 p.221
Band1 Gain [dB]	E1 G[dB]	-18...+18	Sets the gain of Band 1
Band2 Cutoff [Hz]	E2 F[Hz]	50...5.00k	Sets the center frequency of Band 2
Band2 Cutoff [Hz]	E2 Q	0.5...10.0	Sets the bandwidth of Band 2 p.221
Band2 Cutoff [Hz]	E2 G[dB]	-18...+18	Sets the gain of Band 2
Band3 Cutoff [Hz]	E3 F[Hz]	300...10.00k	Sets the center frequency of Band 3
Band3 Q	E3 Q	0.5...10.0	Sets the bandwidth of Band 3 p.221
Band3 Gain [dB]	E3 G[dB]	-18...+18	Sets the gain of Band 3
Band4 Cutoff [Hz]	E4 F[Hz]	500...20.00k	Sets the center frequency of Band 4
Band4 Q	E4 Q	0.5...10.0	Sets the bandwidth of Band 4 p.221
Band4 Gain [dB]	E4 G[dB]	-18...+18	Sets the gain of Band 4
Multitap Delay			
Tap1 Time [ms]	D T1[ms]	0.0...549.0	Sets the Tap1 delay time
Tap1 Level	DT1 Level	0...100	Sets the Tap1 output level p.265
Tap2 Time [ms]	D T2 [ms]	0.0...549.0	Sets the Tap2 delay time
Feedback (Tap2)	D F.back	-100...+100	Sets the Tap2 feedback amount
High Damp [%]		0...100	Sets the damping amount in the high range
[Dly]Wet/Dry	D W/D	Dry, 1 : 99... 99 : 1, Wet	Sets the multitap delay effect balance
[Dly]Source		Off...Tempo	Selects the Wet/Dry modulation source for the multitap delay
[Dly]Amount		-100...+100	Sets the Wet/Dry modulation amount for the multitap delay
Wet/Dry	←	Dry, 1 : 99... 99 : 1, Wet	Sets the balance between the effect and the dry input
Source		Off...Tempo	Selects a modulation source for Wet/Dry
Amount		-100...+100	Sets the modulation amount for Wet/Dry

115: Comp - MDly (Compressor - Multitap Delay)

This effect combines a mono compressor and a multitap delay. You can change the order of the effects.

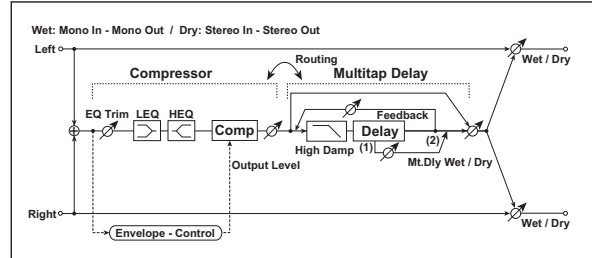

Full parameter	Quick parameter	Value	Explanation
Compressor			
Sensitivity	C Sens	1...100	Sets the sensitivity p.217
Attack	C Attack	1...100	Sets the attack level p.217
Level	C Level	0...100	Sets the compressor output level p.217
Pre EQ Trim	Route	0...100	Sets the EQ input level
LEQ Gain [dB]		-15...+15	Sets the gain of Low EQ
HEQ Gain [dB]		-15...+15	Sets the gain of High EQ
Multitap Delay			
Tap1 Time [ms]	DT1[ms]	0.0...548.0	Sets the Tap1 delay time
Tap1 Level	DT1 Level	0...100	Sets the Tap1 output level p.265
Tap2 Time [ms]	DT2 [ms]	0.0...548.0	Sets the Tap2 delay time
Feedback (Tap2)	D F.back	-100...+100	Sets the Tap2 feedback amount
High Damp [%]		0...100	Sets the damping amount in the high range p.264
[Dly]Wet/Dry	D W/D	Dry, 1 : 99...99 : 1, Wet	Sets the multitap delay effect balance
[Dly]Source		Off...Tempo	Selects the Wet/Dry modulation source for the multitap delay
[Dly]Amount		-100...+100	Sets the Wet/Dry modulation amount for the multitap delay
Routing	Route	Cmp → Dly, Dly → Cmp	Switches the order of the compressor and multitap delay
Wet/Dry	←	Dry, 1 : 99... 99 : 1, Wet	Sets the balance between the effect and the dry input
Source		Off...Tempo	Selects a modulation source for Wet/Dry
Amount		-100...+100	Sets the modulation amount for Wet/Dry

116: Lmtr - MDly (Limiter - Multitap Delay)

This effect combines a mono limiter and a multitap delay. You can change the order of the effects.

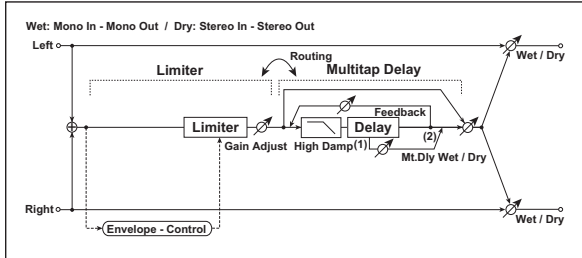

Full parameter	Quick parameter	Value	Explanation	
Limiter				
Ratio	L Ratio	1.0 : 1... 50.0 : 1, Inf : 1	Sets the signal compression ratio p.244	
Threshold [dB]	L Trsh [dB]	-40...0	Sets the level above which the compressor is applied p.244	
Attack	L Attack	1...100	Sets the attack time	
Release	L Release	1...100	Sets the release time	
Gain Adjust [dB]	L G [dB]	-Inf...+24	Sets the limiter output gain p.244	
Multitap Delay				
Tap1 Time [ms]	DT1 [ms]	0.0...1360.0	Sets the Tap1 delay time	
Tap1 Level	DT1 Level	0...100	Sets the Tap1 output level p.265	
Tap2 Time [ms]	DT2 [ms]	0.0...1360.0	Sets the Tap2 delay time	
Feedback (Tap2)	D F.back	-100...+100	Sets the Tap2 feedback amount	
High Damp [%]		0...100	Sets the damping amount in the high range p.264	
[Dly]Wet/Dry	D W/D	Dry, 1 : 99... 99 : 1, Wet	Sets the multitap delay effect balance	D^{mod}
[Dly]Source		Off...Tempo	Selects the multitap delay's Wet/Dry modulation source	
[Dly]Amount		-100...+100	Sets the multitap delay's Wet/Dry modulation amount	
Routing	Route	Lmt → Dly, Dly → Lmt	Switches the order of the limiter and multitap delay	
Wet/Dry	←	Dry, 1 : 99... 99 : 1, Wet	Sets the balance between the effect and the dry input	D^{mod}
Source		Off...Tempo	Selects a modulation source for Wet/Dry	
Amount		-100...+100	Sets the modulation amount for Wet/Dry	

117: Xctr - MDly (Exciter - Multitap Delay)

This effect combines a mono exciter and a multitap delay.

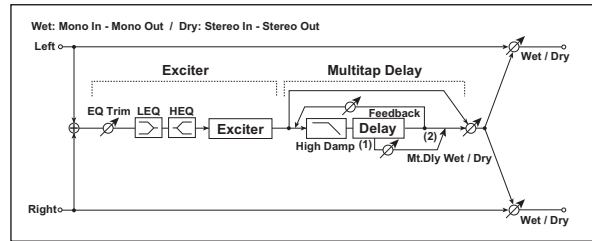

Full parameter	Quick parameter	Value	Explanation	
Exciter				
Blend	X Blend	-100...+100	Sets the intensity (depth) of the Exciter effect p.222	
Emphasis Freq	X Freq	0...70	Sets the frequency range to be emphasized p.222	
Pre Trim		0...100	Sets the EQ input level	
LEQ Gain [dB]		-15...+15	Sets the gain of Low EQ	
HEQ Gain [dB]		-15...+15	Sets the gain of High EQ	
Multitap Delay				
Tap1 Time [ms]	DT1 [ms]	0.0...1360.0	Sets the Tap1 delay time	
Tap1 Level	DT1 Level	0...100	Sets the Tap1 output level p.265	
Tap2 Time [ms]	DT2 [ms]	0.0...1360.0	Sets the Tap2 delay time	
Feedback (Tap2)	D F.back	-100...+100	Sets the Tap2 feedback amount	
High Damp [%]		0...100	Sets the damping amount in the high range p.264	
[Dly]Wet/Dry	D W/D	Dry, 1 : 99... 99 : 1, Wet	Sets the multitap delay effect balance	D^{mod}
[Dly]Source		Off...Tempo	Selects the Wet/Dry modulation source for the multitap delay	
[Dly]Amount		-100...+100	Sets the Wet/Dry modulation amount for the multitap delay	
Wet/Dry	←	Dry, 1 : 99... 99 : 1, Wet	Sets the balance between the effect and the dry input	D^{mod}
Source		Off...Tempo	Selects a modulation source for Wet/Dry	
Amount		-100...+100	Sets the modulation amount for Wet/Dry	

118: OD - MDly (Overdrive/Hi.Gain - Multitap Delay)

This effect combines a mono overdrive/high-gain distortion and a multitap delay.

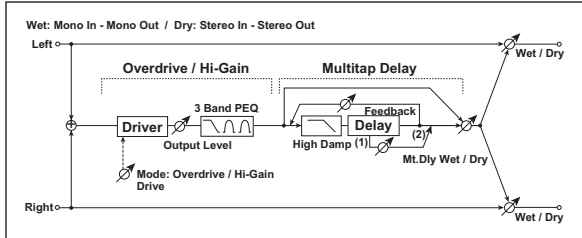

Full parameter	Quick parameter	Value	Explanation	
Overdrive/Hi-Gain				
Drive Mode	O Mode	Overdrive, Hi-Gain	Switches between overdrive and high-gain distortion	
Drive	O Drive	1...100	Sets the degree of distortion p.229	
Level	O Out Level	0...50	Sets the overdrive output level p.229	
Source		Off...Tempo	Selects the modulation source for the overdrive output level	
Amount		-50...+50	Sets the modulation amount of the overdrive output level	
Low Cutoff [Hz]		20...1.00k	Sets the center frequency for Low EQ (shelving type)	
Low Gain [dB]	O Low [dB]	-18...+18	Sets the gain of Low EQ	
Mid1 Cutoff [Hz]		300...10.00k	Sets the center frequency for Mid/High EQ 1 (peaking type)	
Mid1 Q		0.5...10.0	Sets the band width of Mid/High EQ 1 p.221	
Mid Gain [dB]	O Mid1 [dB]	-18...+18	Sets the gain of Mid/High EQ 1	
Mid2 Cutoff [Hz]		500...20.00k	Sets the center frequency for Mid/High EQ 2 (peaking type)	
Mid2 Q		0.5...10.0	Sets the band width of Mid/High EQ 2 p.221	
Mid2 Gain [dB]	O Mid2 [dB]	-18...+18	Sets the gain of Mid/High EQ 2	
Multitap Delay				
Tap1 Time [ms]	DT1 [ms]	0.0...1360.0	Sets the Tap1 delay time	
Tap1 Level	DT1 Level	0...100	Sets the Tap1 output level p.265	
Tap2 Time [ms]	DT2 [ms]	0.0...1360.0	Sets the Tap2 delay time	
Feedback (Tap2)	D F.back	-100...+100	Sets the Tap2 feedback amount	
High Damp [%]		0...100	Sets the damping amount in the high range p.264	
[Dly]Wet/Dry	D W/D	Dry, 1 : 99... 99 : 1, Wet	Sets the multitap delay effect balance	
[Dly]Source		Off...Tempo	Selects the Wet/Dry modulation source for the multitap delay	
[Dly]Amount		-100...+100	Sets the Wet/Dry modulation amount for the multitap delay	
Wet/Dry	←	Dry, 1 : 99... 99 : 1, Wet	Sets the balance between the effect and the dry input	
Source		Off...Tempo	Selects a modulation source for Wet/Dry	
Amount		-100...+100	Sets the modulation amount for Wet/Dry	

119: Flng - Dly (Chorus/Flanger - Multitap Delay)

This effect combines a mono chorus/flanger and a multitap delay.

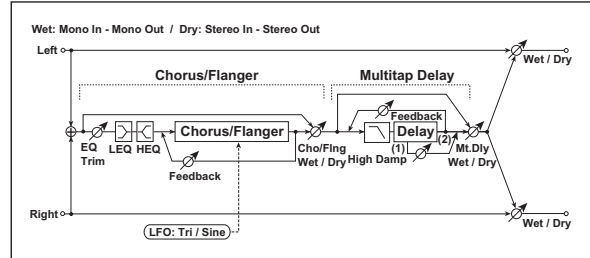

Full parameter	Quick parameter	Value	Explanation	
Chorus/Flanger				
LFO Waveform		Triangle, Sine	Selects the LFO Waveform	
LFO Freq [Hz]	F LFO [Hz]	0.02...20.00	Sets the speed of the LFO	
Delay Time [ms]	F Dly [ms]	0.0...1350.0	Sets the delay time	
Depth	F Depth	0...100	Sets the depth of LFO modulation	
Feedback	F F.back	-100...+100	Sets the feedback amount p.254	
Pre EQ Trim		0...100	Sets the EQ input level	
[LEQ Gain [dB]		-15...+15	Sets the gain of Low EQ	
EQ Gain [dB]		-15...+15	Sets the gain of High EQ	
Wet/Dry	F W/D	-Wet...-1 : 99, Dry, 1 : 99...Wet	Sets the effect balance of the chorus/flanger p.225, p.254	
Multitap Delay				
Tap1 Time [ms]	D T1 [ms]	0.0...1360.0	Sets the Tap1 delay time	
Tap1 Level	D T1 Level	0...100	Sets the Tap1 output level p.265	
Tap2 Time [ms]	D T2 [ms]	0.0...1360.0	Sets the Tap2 delay time	
Feedback (Tap2)	D F.back	-100...+100	Sets the Tap2 feedback amount	
High Damp [%]		0...100	Sets the damping amount in the high range p.264	
[Dly]Wet/Dry	D W/D	Dry, 1 : 99... 99 : 1, Wet	Sets the multitap delay effect balance	
[Dly]Source		Off...Tempo	Selects the Wet/Dry modulation source for the multitap delay	
[Dly]Amount		-100...+100	Sets the Wet/Dry modulation amount for the multitap delay	
Wet/Dry	←	Dry, 1 : 99... 99 : 1, Wet	Sets the balance between the effect and the dry input	
Source		Off...Tempo	Selects a modulation source for Wet/Dry	
Amount		-100...+100	Sets the modulation amount for Wet/Dry	

120: Rev - Gate (Reverb - Gate)

This effect combines a mono reverb and a gate.

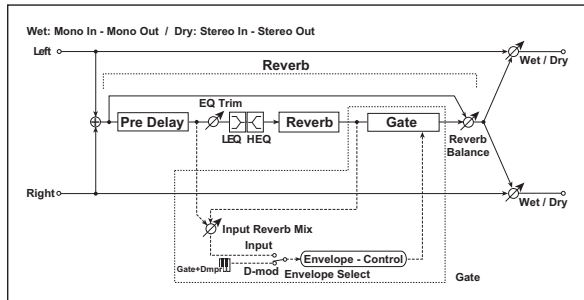

Full parameter	Quick parameter	Value	Explanation	
Reverb				
Reverb Time [sec]	R Time[s]	0.1...10.0	Sets the reverberation time	
Pre EQ Trim		0...100	Sets the EQ input level	
PreLEQ Fc		Low, Mid-Low	Selects the cutoff frequency (low or mid-low) of the low-range equalizer	
LEQ Gain [dB]		-15.0...+15.0	Sets the gain of Low EQ	
Pre HEQ Fc		High, Mid-High	Selects the cutoff frequency (high or mid-high) of the high-range equalizer	
HEQ Gain [dB]		-15.0...+15.0	Sets the gain of High EQ	
High Damp [%]	R HiDmp[%]	0...100	Sets the damping amount in the high range	
Pre Delay [ms]	R PreD[ms]	0...200	Sets the delay time of the reverb sound and gate control signal	
Reverb Balance	R Bal	Dry, 1 : 99... 99 : 1, Wet	Sets the reverb effect balance	
Gate				
Envelope Select	G Env Sel	D-mod, Input	Switches between modulation source control and input signal control p.279	
Source	Src	Off...Tempo	Selects the modulation source that controls the gate when Envelope Select is set to D-mod p.279	D-mod
Input Reverb Mix		Dry, 1 : 99... 99 : 1, Wet	Sets the balance between the dry and reverb sounds of the gate control signal p.279	
Polarity	G Polarity	+, -	Switches between non-invert and invert of the gate on/off state p.220	
Threshold	G Threshold	0...100	Sets the gate threshold level p.279	
Attack		1...100	Sets the attack time p.220	
Release	G Release	1...100	Sets the release time p.220	
Wet/Dry	←	Dry, 1 : 99... 99 : 1, Wet	Sets the balance between the effect and the dry input	D-mod
Source		Off...Tempo	Selects a modulation source for Wet/Dry	
Amount		-100...+100	Sets the modulation amount for Wet/Dry	

Envelope Select

Source

Input Reverb Mix

Threshold

The “Envelope Select” parameter enables you to select whether turning the gate on and off is triggered by the input signal level or controlled directly by the modulation source. You can select from Off to Gate2+Dmpr for the Source parameter to specify the modulation source.

When “Envelope Select” is set to Input, the gate is controlled by the level of signals that are the combination of the dry sound and the reverb sound. When the signal level exceeds the threshold, the gate opens and the reverb sound is output.

Normally, set “Input Reverb Mix” to Dry (the gate is controlled only by the dry sound). If you wish to extend the gate time, set the “Input Reverb Mix” value higher and adjust the “Threshold” value.

Double Size effects

D00: St.MltLmt (Stereo Multiband Limiter)

This is a stereo multiband limiter.

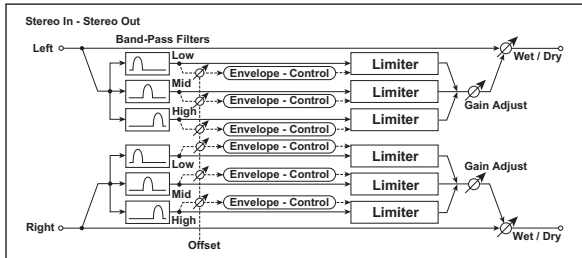

Full parameter	Quick parameter	Value	Explanation	
Ratio		1.0 : 1... 50.0 : 1, Inf : 1	Sets the signal compression ratio p.244	
Threshold [dB]	Thresh[dB]	-40...0	Sets the level above which the compressor is applied p.244	
Attack		1...100	Sets the attack time	
Release		1...100	Sets the release time	
Low Offset [dB]	LowOfst[dB]	-40...0	Sets the low range gain of trigger signal p.219	
Mid Offset [dB]	MidOfst[dB]	-40...0	Sets the mid range gain of trigger signal p.219	
High Offset [dB]	Hi Ofst[dB]	-40...0	Sets the high range gain of trigger signal p.219	
Gain Adjust [dB]	Gain [dB]	-Inf, -38...+24	Sets the output gain p.244	
Source		Off...Tempo	Selects the modulation source for the output gain	
Amount		-63...+63	Sets the modulation amount of the output gain	
Wet/Dry	←	Dry, 1 : 99... 99 : 1, Wet	Sets the balance between the effect and the dry input	
Source		Off...Tempo	Selects a modulation source for Wet/Dry	
Amount		-100...+100	Sets the modulation amount for Wet/Dry	

D01: OD/HG Wah (Overdrive/Hyper Gain Wah)

This distortion effect has two modes: overdrive and hyper-gain that produces a strong distortion. A higher high-gain setting is required for this effect relative to a normal-size effect.

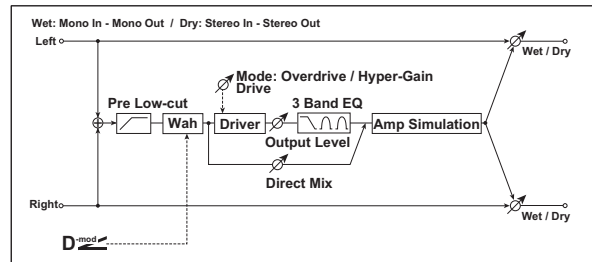

Full parameter	Quick parameter	Value	Explanation	
Wah	←	Off, On	Switches Wah on/off p.229	
Source		Off...Tempo	Selects the modulation source that switches the Wah on and off p.229	
Switch Mode		Toggle, Moment	Selects the switching mode for the modulation source that switches the Wah on and off p.229	
Sweep Range		-10...+10	Sets the range of Wah p.229	
Source	Src	Off...Tempo	Selects the modulation source that controls the Wah p.229	
Drive Mode	Mode	Overdrive, Hyper-Gain	Switches between overdrive and hi-gain distortion	
Drive	←	1...120	Sets the degree of distortion p.229	
Pre Low Cut		0...10	Sets the low range cut amount of the distortion input p.229	
Output Level	Out Level	0...50	Sets the output level p.229	
Source		Off...Tempo	Selects the modulation source for the output level	
Amount		-50...+50	Sets the modulation amount of the output level	
Low Cutoff [Hz]		20...1.00k	Sets the center frequency for Low EQ (shelving type)	
Gain [dB]	Low G[dB]	-18...+18	Sets the gain of Low EQ	
Mid1 Cutoff [Hz]		300...10.00k	Sets the center frequency for Mid/High EQ 1 (peaking type)	
Q		0.5...10.0	Sets the band width of Mid/High EQ 1 p.221	
Gain [dB]	Mid1 G[dB]	-18...+18	Sets the gain of Mid/High EQ 1	
Mid2 Cutoff [Hz]		500...20.00k	Sets the center frequency for Mid/High EQ 2 (peaking type)	
Q		0.5...10.0	Sets the band width of Mid/High EQ 2 p.221	
Gain [dB]	Mid2 G[dB]	-18...+18	Sets the gain of Mid/High EQ 2	

Direct Mix	←	0...50	Sets the amount of the dry sound mixed to the distortion	
Speaker Simulation	SpeakerSim	Off, On	Switches the speaker simulation on/off	
Wet/Dry	←	Dry, 1 : 99... 99 : 1, Wet	Sets the balance between the effect and the dry input	D ^{mod}
Source		Off...Tempo	Selects a modulation source for Wet/Dry	
Amount		-100...+100	Sets the modulation amount for Wet/Dry	

D02: GAmp + P4EQ (Guitar Amp Model + Parametric 4-Band EQ)

This combines a guitar amp simulation (which even faithfully replicates the distortion and tone control circuitry) with a four-band equalizer.

By using this in conjunction with “021: St.Gt Cab (Stereo Guitar Cabinet)” p.229, you can obtain an even more realistic guitar sound that simulates a guitar amp + speaker cabinet.

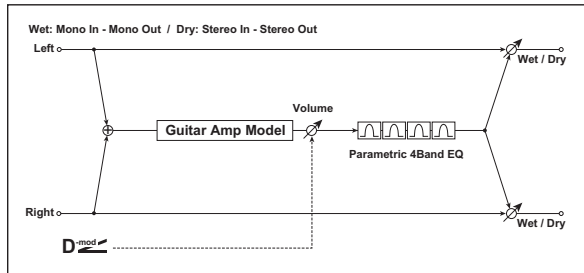

Full parameter	Quick parameter	Value	Explanation	
Guitar Amp Amp Type	Amp	VOX AC15, VOX AC15TB, VOX AC30, VOX AC30TB, UK BLUES, UK 70'S, UK 80'S, UK 90'S, UK MODERN, US MODERN, US HIGAIN, BOUTIQUE OD, BOUTIQUE CL, BLACK 2x12, TWEED - 1x12, TWEED - 4x10	Selects the type of the amplifier p.281	
Drive Gain	←	0...100	Sets the input gain	
Volume	←	0...100	Sets the output level	D ^{mod}
Source		Off...Tempo	Selects the modulation source for the output level	
Amount		-100...+100	Sets the modulation amount of the output level	
Bass	←	0...100	Sets the bass (low range) level	
Middle	←	0...100	Sets the middle (mid range) level	
Treble	←	0...100	Sets the treble (high range) level	
Presence	Cut/Presen	0...100	Sets the presence (high-frequency tone) p.281	
P4EQ EQ Switch	Post P4EQ	Thru, On	Selects through or on for the equalizer p.281	
Band1 Cutoff [Hz]		20...1.00k	Sets the center frequency of Band 1	

Q		0.5...10.0	Sets Band 1's bandwidth	
Gain [dB]	B1 G[dB]	-18...+18	Sets the gain of Band 1	
Band2 Cutoff [Hz]		50...5.00k	Sets the center frequency of Band 2	
Q		0.5...10.0	Sets Band 2's bandwidth	
Gain [dB]	B2 G[dB]	-18...+18	Sets the gain of Band 2	
Band3 Cutoff [Hz]		300...10.00k	Sets the center frequency of Band 3	
Q		0.5...10.0	Sets Band 3's bandwidth	
Gain [dB]	B3 G[dB]	-18...+18	Sets the gain of Band 3	
Band4 Cutoff [Hz]		500...20.00k	Sets the center frequency of Band 4	
Q		0.5...10.0	Sets Band 4's bandwidth	
Gain [dB]	B4 G[dB]	-18...+18	Sets the gain of Band 4	
Wet/Dry	←	Dry, 1 : 99... 99 : 1, Wet	Sets the balance between the effect and the dry input	D ^{mod}
Source		Off...Tempo	Selects a modulation source for Wet/Dry	
Amount		-100...+100	Sets the modulation amount for Wet/Dry	

Amp Type Presence

If the Amp Type is VOX AC15...VOX AC30TB, this sets the attenuation of the high-frequency range. For other types, this sets the boost of the high-frequency range. This corresponds to the Cut knob control of amps made by the VOX Corporation.

Post P4EQ

By chaining this with S021: St.Gt Cab you can simulate the combination of a guitar amp and speaker cabinet. In this case, we recommend that you set “Post P4EQ” to “Thru,” but if necessary you can turn it “On” and adjust the tone.

Recommended Combinations of Guitar Amp Models and Cabinet Simulators:

Amp Type	Cabinet Type
VOX AC15	VOX AC15 - 1x12
VOX AC15TB	VOX AC15 - 1x12
VOX AC30	VOX AC30 - 2x12
VOX AC30TB	VOX AC30 - 2x12
UK BLUES	UK H30 - 4x12
UK 70'S	UK H30 - 4x12
UK 80'S	UK T75 - 4x12
UK 90'S	UK T75 - 4x12
UK MODERN	UK T75 - 4x12, US V30 - 4x12
US MODERN	US V30 - 4x12
US HIGAIN	US V30 - 4x12, UK T75 - 4x12
BOUTIQUE OD	UK H30 - 4x12
BOUTIQUE CL	UK H30 - 4x12
BLACK 2x12	BLACK - 2x12
TWEED - 1x12	TWEED - 1x12
TWEED - 4x10	TWEED - 4x10

D03: GAmpCLEAN (Guitar Amp Model CLEAN)

This models the clean channel of a amp that went on sale in 1975 and contained two 12" speakers. As the name suggests, it produces a clean tone with a tight sounding character, and a deep and compact low-end.

D04: GAmpSUPER (Guitar Amp Model SUPER)

This American combo amp with four 10" speakers was produced during the years 1963–1968, and was known for its big, clean sound and its warm and husky sound when driven heavily.

D05: GAmpTWEED (Guitar Amp Model TWEED)

This American-made tweed-covered 1957 model combo amp with two 12" speakers is known for its rich, clean tone that is ideal for classic rock, blues, and country. By raising the volume you can also produce a powerful and punchy overdrive sound.

D06: GAmpUS-HG (Guitar Amp Model US-HG)

This models a 100W boutique amp head produced in North Hollywood. An overdrive tone with a rich harmonic structure is combined with a relaxed sustain, making for an enjoyable playing experience.

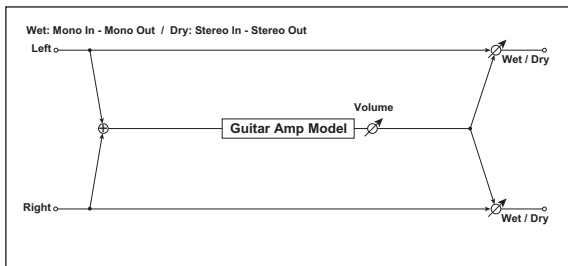

Full parameter	Quick parameter	Value	Explanation	
Drive	←	0...100	Sets the input gain	
Volume	←	0...100	Sets the output level	
Bass	←	0...100	Sets the bass (low range) level	
Middle	←	0...100	Sets the middle (mid range) level	
Treble	←	0...100	Sets the treble (high range) level	
Presence	←	0...100	Sets the presence (high-frequency tone)	
Wet/Dry	←	Dry, 1 : 99...99 : 1, Wet	Sets the balance between the effect and the dry input	
Source		Off...Tempo	Selects a modulation source for Wet/Dry	
Amount		-100...+100	Sets the modulation amount for Wet/Dry	

Examples of amp and cabinet combinations

We recommend that you use these amp model effects in a chain with the cabinet model effect (S21: St.Gt Cab). You are free to use any combination to create a variety of sounds, so

try out various combinations and listen to the result. Here are some typical combinations.

D03: GAmpCLEAN	1x12 TWEED
	2x10 BLACK
	2x12 BLACK
	4x12 UK H30
D04: GAmpSUPER	1x12 TWEED
	4x10 TWEED
	2x12 BLACK
	4x12 UK H30
D05: GAmpTWEED:	1x12 TWEED
	2x10 BLACK
	2x12 BLACK
D06: GAmpUS-HG	4x12 UK T75
	4x12 US V30

D07: B.TubeAmp (Bass Tube Amp Model + Cabinet)

This simulates a bass amp (with gain and drive) and speaker cabinet.

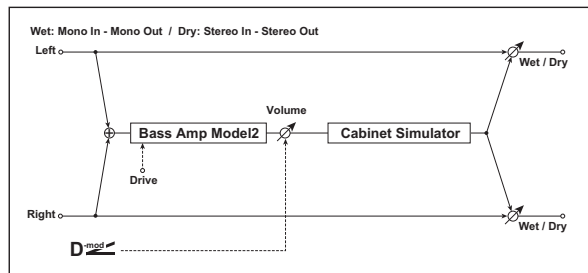

Full parameter	Quick parameter	Value	Explanation	
Bass Amp Amp Type	Amp	STUDIO COMBO	Selects the type of the amplifier p.281 A tube combo ideal for the Motown sound	
		VOX AC100	A 100W tube amp AC100 made by Vox	
		UK MAJOR	A 200W tube amp made in the UK	
Drive Gain	←	0...100	Sets the input gain	
Volume	←	0...100	Sets the output level	
Source		Off...Tempo	Selects the modulation source for the output level	
Amount		-100...+100	Sets the modulation amount of the output level	
Bass	←	0...100	Sets the bass (low range) level	
Middle	←	0...100	Sets the middle (mid range) level	
Treble	←	0...100	Sets the treble (high range) level	
Presence	←	0...100	Sets the presence (high-frequency tone)	
Cabinet Cabinet On	Cabinet Sim	Off, On	Switches the cabinet simulator on/off	

Type	Cab	LA - 4x10, MODERN - 4x10, METAL - 4x10, CLASSIC - 8x10, UK - 4x12, STUDIO - 1x15, JAZZ - 1x15, VOX AC100 - 2x15, US - 2x15, UK - 4x15, LA - 1x18, COMBI - 1x12 & 1x18	Selects the cabinet type p.231, p.283	
Wet/Dry	←	Dry, 1 : 99...99 : 1, Wet	Sets the balance between the effect and the dry input	D^{mod}
Source		Off...Tempo	Selects a modulation source for Wet/Dry	
Amount		-100...+100	Sets the modulation amount for Wet/Dry	

**Amp Type
Cabinet Type**

Recommended Combinations of Bass Amp Models and Cabinets:

Amp Type	Cabinet Type
STUDIO COMBO	STUDIO - 1x15
AC100	VOX AC100 - 2x15
UK MAJOR	UK - 4x15, UK - 4x12

**D08: St. Mic
(Stereo Mic Modeling + PreAmp)**

This is a stereo mic and preamp simulator (See "028: Mic Model (Mic Modeling + PreAmp)" on page 232.). For example you might use this to simulate micing of a stereo source such as a rotary speaker.

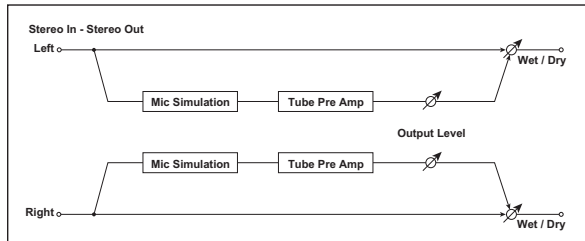

D09: Vocoder

This effect applies the timbral character of a one signal (the modulator) to a second signal (the carrier). On the microSTATION, an external source such as a mic cannot be used as the modulator source, but you can create unique effects by using an internal sound source as the modulator. Try selecting voice-type sounds, rhythms, or sound effects as the modulator. The most suitable choices for the carrier are sounds that contain a large number of overtones, such as strings or distorted guitar. For details on how to adjust the settings, refer to "Example: Vocoder (Combination)" on page 207.

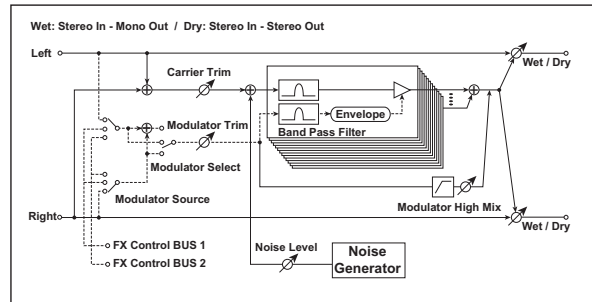

Full parameter	Quick parameter	Value	Explanation	
Carrier Trim		0...100	Sets the Carrier input level	
Noise Level		0...100	Sets the noise mix level to the Carrier p.283	D^{mod}
Source		Off...Tempo	Selects the modulation source for the noise mix level	
Amount		-100...+100	Sets the modulation amount for the noise mix level	
Modulator Trim		0...100	Sets the Modulator input level	
Source	Mod Src	Input, FX Control 1, FX Control 2	Selects the modulator input	
Select		L/R Mix, L Only, R Only	Selects whether to use the left/right mix, only left, or only right of the modulator input	
Formant Shift	Formant Sft	-2...+2	Sets the height of the frequency for the vocoder effect p.283	
Response	←	0...100	Sets the speed of the response to the modulator input	
Low Gain [dB]	LowGain[dB]	-12...+12	Sets the low-range output level of the vocoder	
High Gain [dB]	HiGain[dB]	-12...+12	Sets the high-range output level of the vocoder	
Mod. High Mix		0...100	Sets the high-range output level of the modulator p.283	
Wet/Dry	←	Dry, 1 : 99...99 : 1, Wet	Sets the balance between the effect and the dry input	D^{mod}
Source		Off...Tempo	Selects a modulation source for Wet/Dry	
Amount		-100...+100	Sets the modulation amount for Wet/Dry	

Formant Shift

By offsetting the Carrier filter, you can adjust the height of the frequency range where the vocoder effect is applied. The tonal quality will change significantly.

Noise Level

This parameter enables you to mix white noise with the Carrier.

Mod. High Mix

This parameter sets the high-range output level of the modulator sound. If the modulator is a human voice, it will make the words more clear.

**D10: Rotary OD
(Rotary Speaker Overdrive)**

This is a stereo rotary speaker effect. It has an internal speaker simulator that simulates overdrive (recreating the amp distortion) and characteristics of the rotary speaker, producing a very realistic rotary speaker sound.

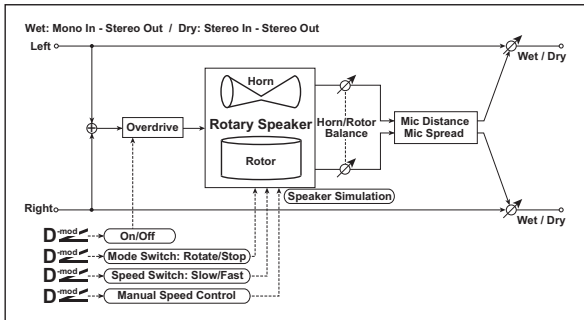

Full parameter	Quick parameter	Value	Explanation	
Overdrive	←	Off, On	Switches overdrive on/off	
Source	Src	Off...Tempo	Selects a modulation source to switch overdrive on/off	
Switch Mode		Toggle, Moment	Sets the switch mode for overdrive on/off modulation p.284	
Gain	OD Gain	0...100	Determines the degree of distortion	
Level	OD Level	0...100	Sets the overdrive output level	
Tone	OD Tone	0...15	Sets the tonal quality of the overdrive	
Speaker Simulator	SpeakerSim	Off, On	Switches the speaker simulation on/off	
Mode Switch	Mode SW	Rotate, Stop	Switches between speaker rotation and stop	D ^{mod} ←
Source		Off...Tempo	Selects a modulation source for Rotate/Stop	
Switch Mode		Toggle, Moment	Sets the switch mode for Rotate/Stop modulation p.250	
Speed Switch	Speed SW	Slow, Fast	Switches the speaker rotation speed between slow and fast	D ^{mod} ←
Source	Src	Off...Tempo	Selects a modulation source for Slow/Fast	
Switch Mode		Toggle, Moment	Sets the switch mode for Slow/Fast modulation p.250	
H/R. Balance		Rotor, 1...99, Horn	Sets the volume balance between the high-range horn and low-range rotor	
Manual Speed		Off...Tempo	Sets a modulation source for direct control of rotation speed p.250	D ^{mod} ←
Horn Acceleration		0...100	Sets how quickly the horn rotation speed changes p.250	
Ratio		Stop, 0.50...2.00	Adjusts the (high-frequency) horn rotation speed. Standard value is 1.00. "Stop" stops the rotation	

Rotor Acceleration		0...100	Sets how quickly the rotor speed changes p.250	
Ratio		Stop, 0.50...2.00	Adjusts the (low-frequency) rotor rotation speed. Standard value is 1.0. "Stop" stops the rotation	
Mic Distance		0...100	Distance between the microphone and rotary speaker p.250	
Spread		0...100	Angle of left and right microphones p.250	
Wet/Dry	←	Dry, 1 : 99... 99 : 1, Wet	Sets the balance between the effect and the dry input	D ^{mod} ←
Source		Off...Tempo	Selects a modulation source for Wet/Dry	
Amount		-100...+100	Sets the modulation amount for Wet/Dry	

Switch Mode

This parameter determines how to switch on/off the overdrive via a modulation source. When "Switch Mode" = Toggle, overdrive is turned on/off each time the pedal or joystick is operated.

MIDI Overdrive will be switched on/off each time the value of the modulation source exceeds 64.

When "Switch Mode" = Moment, overdrive is applied only when you press the pedal or operate the joystick.

MIDI Only when the value for the modulation source is 64 or higher, the overdrive effect is applied.

D11: Mtap Cho (Multitap Chorus/Delay)

This effect has six chorus blocks with different LFO phases. You can produce a complex stereo image by setting a different delay time and depth for each block. You can control the delay output level via a modulation source.

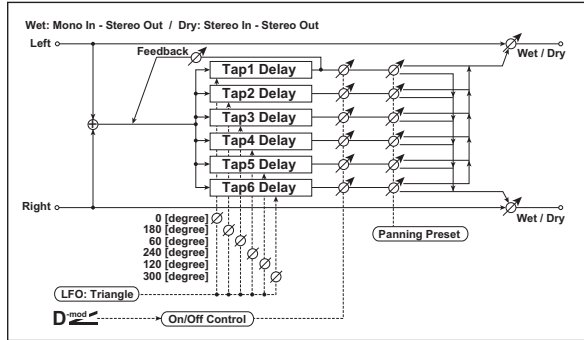

Full parameter	Quick parameter	Value	Explanation
LFO Freq [Hz]	LFO [Hz]	0.02...13.00	Sets the speed of the LFO
Tap1 Delay (000) [ms]	Tap1 [ms]	0...2000	Sets the Tap1 (LFO phase=0 degrees) delay time
Depth	Tap1 Depth	0...30	Sets the Tap1 chorus depth
Status	Tap1	Always On, Always Off, On→Off (Dm), Off→On (Dm)	Selects on, off, or modulation source for the control of Tap1 output p.285
Tap2 Delay (180) [ms]	Tap2 [ms]	0...2000	Sets the Tap2 (LFO phase=180 degrees) delay time
Depth	Tap2 Depth	0...30	Sets the Tap2 chorus depth
Status		Always On, Always Off, On→Off (Dm), Off→On (Dm)	Selects on, off, or modulation source for the control of Tap2 output p.285
Tap3 Delay (060) [ms]	Tap3 [ms]	0...2000	Sets the Tap3 (LFO phase=60 degrees) delay time
Depth	Tap3 Depth	0...30	Sets the Tap3 chorus depth
Status	Tap3	Always On, Always Off, On→Off (Dm), Off→On (Dm)	Selects on, off, or modulation source for the control of Tap3 output p.285
Tap4 Delay (240) [ms]	Tap4 [ms]	0...2000	Sets the Tap4 (LFO phase=240 degrees) delay time
Depth	Tap4 Depth	0...30	Sets the Tap4 chorus depth
Status	Tap4	Always On, Always Off, On→Off (Dm), Off→On (Dm)	Selects on, off, or modulation source for the control of Tap4 output p.285
Tap5 Delay (120) [ms]	Tap5 [ms]	0...2000	Sets the Tap5 (LFO phase=120 degrees) delay time
Depth	Tap5 Depth	0...30	Sets the Tap5 chorus depth
Status	Tap5	Always On, Always Off, On→Off (Dm), Off→On (Dm)	Selects on, off, or modulation source for the control of Tap5 output p.285
Tap6 Delay (300) [ms]	Tap6 [ms]	0...2000	Sets the Tap6 (LFO phase=300 degrees) delay time

Depth	Tap6 Depth	0...30	Sets the Tap6 chorus depth
Status	Tap6	Always On, Always Off, On→Off (Dm), Off→On (Dm)	Selects on, off, or modulation source for the control of Tap6 output p.285
Tap1 Feedback	Feedback	-100...+100	Sets the Tap1 feedback amount
Source		Off...Tempo	Selects the modulation source for the Tap output level, feedback amount, and effect balance
Amount		-100...+100	Sets the modulation amount of Tap1 feedback amount
Panning Preset		1: L 1 2 3 4 5 6 R 2: L 1 3 5 2 4 6 R 3: L 1 3 5 2 4 6 R 4: L 1 4 5 6 3 2 R	Selects the stereo panning pattern for each tap p.285
Wet/Dry	←	Dry, 1 : 99... 99 : 1, Wet	Sets the balance between the effect and the dry input
Source		Off...Tempo	Selects a modulation source for Wet/Dry
Amount		-100...+100	Sets the modulation amount for Wet/Dry

Status

These parameters set the output status of each Tap.

Always On: Output is always on. (No modulation)

Always Off: Output is always off. (No modulation)

On→Off (dm): Output level is switched from on to off depending on the modulation source.

Off→On (dm): Output level is switched from off to on depending on the modulation source.

Combining these parameters, you can change from 4-phase chorus to two-tap delay by crossfading them gradually via the modulation source during a performance.

Panning Preset

This parameter selects combinations of stereo images of the tap outputs.

D12: St.P.Sftr (Stereo Pitch Shifter)

This is a stereo pitch shifter. The pitch shift amount for the left and right channels can be reversed from each other.

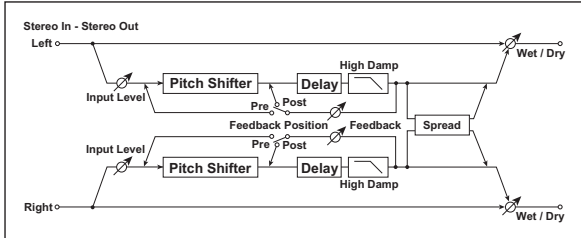

Full parameter	Quick parameter	Value	Explanation	
Input Lvl Dmod [%]		-100...+100	Sets the modulation amount of the input level p.258	
Source		Off...Tempo	Selects the modulation source for the input level p.258	
Mode	←	Slow, Medium, Fast	Switches Pitch Shifter mode p.250	
L/R Pitch	L/R	Normal, Up/Down	Determines whether or not the L/R pitch shift amount is inverted p.286	
Shift [1/2tone]	Pitch	-24...+24	Sets the pitch shift amount in steps of a semitone p.259	
Source		Off...Tempo	Selects the modulation source of pitch shift amount p.259	
Amount		-24...+24	Sets the modulation amount of pitch shift amount p.259	
Fine [cents]	Fine [c]	-100...+100	Sets the pitch shift amount in steps of one cent p.259	
Amount		-100...+100	Sets the modulation amount of pitch shift amount p.259	
L Delay Time [ms]	L Dly[ms]	0...2000	Sets the delay time for the left channel	
R Delay Time [ms]	R Dly[ms]	0...2000	Sets the delay time for the right channel	
Feedback Position	FB Posit	Pre, Post	Switches the feedback connection p.259	
Feedback	←	-100...+100	Sets the feedback amount p.259	
High Damp [%]		0...100	Sets the damping amount in the high range	
Spread		-100...+100	Sets the width of the stereo image of the effect sound p.264	
Wet/Dry	←	Dry, 1 : 99... 99 : 1, Wet	Sets the balance between the effect and the dry input	
Source		Off...Tempo	Selects a modulation source for Wet/Dry	
Amount		-100...+100	Sets the modulation amount for Wet/Dry	

L/R Pitch

When you select Up/Down for this parameter, the pitch shift amount for the right channel will be reversed. If the pitch shift amount is positive, the pitch of the left channel is raised, and the pitch of the right channel is lowered.

D13: Early Ref (Early Reflections)

This early reflection effect has more precise early reflections with twice the maximum length of a normal-size effect (See "113: Early Reflections" on page 275). You can create a very smooth and dense sound.

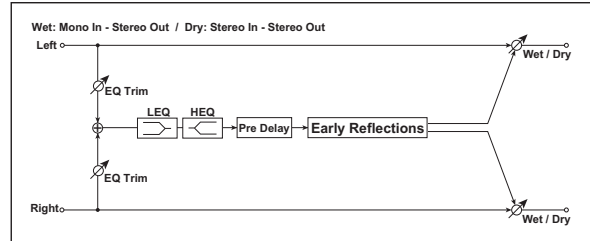

Full parameter	Quick parameter	Value	Explanation	
Pre EQ Trim	PreEQ Trim	0...100	Sets the input level of EQ applied to the effect sound	
Pre LEQ Fc		Low, Mid-Low	Selects the cutoff frequency (low or mid-low) of the low-range equalizer	
LEQ Gain [dB]	LEQ [dB]	-15.0...+15.0	Sets the gain of Low EQ	
Pre HEQ Fc		High, Mid-High	Selects the cutoff frequency (high or mid-high) of the high-range equalizer	
HEQ Gain [dB]	HEQ [dB]	-15.0...+15.0	Sets the gain of High EQ	
Type	←	Sharp, Loose, Modulated, Reverse	Selects the decay curve for the early reflection p.275	
ER Time [ms]	Time [ms]	10...540	Sets the time length of early reflection	
Pre Delay [ms]	PreDly[ms]	0...200	Sets the time taken from the original sound to the first early reflection	
Wet/Dry	←	Dry, 1 : 99... 99 : 1, Wet	Sets the balance between the effect and the dry input	
Source		Off...Tempo	Selects a modulation source for Wet/Dry	
Amount		-100...+100	Sets the modulation amount for Wet/Dry	

Appendices

Alternate Modulation Source (AMS)

Alternate Modulation Overview

Alternate Modulation Sources

Alternate Modulation lets you use controllers, envelopes, LFOs, etc. to modulate Program parameters. You can use one controller to modulate multiple parameters simultaneously. You can also create complex modulation setups in which (for example) an envelope modulates the frequency of an LFO, and that LFO is then used to modulate a filter.

Programs provide 46 types (84 destinations) for alternate modulation.

AMS Mixers

The AMS Mixers combine two AMS sources into one, or process an AMS source to make it into something new. For instance, they can add two AMS sources together, or use one AMS source to scale the amount of another. You can also use them to change the shapes of LFOs and EGs in various ways, modify the response of realtime controllers, and more.

The AMS Mixer outputs appear in the list of AMS sources, just like the LFOs and EGs.

The original, unmodified inputs to the AMS Mixers are still available as well. For instance, if you use LFO 1 as an input to a AMS Mixer, you can use the processed version of the LFO to control one AMS destination, and the original version to control another.

Finally, you can cascade two AMS Mixers together, by using one as the input of another.

For more information, please see “OSC1 AMS Mix” on page 122.

AMS (Alternate Modulation Source) List

Physical and MIDI controllers

Off

This means that no modulation source is selected.

Note Number

This is the note’s MIDI note number, from 0 (C-2) to 127 (G9).

Velocity

This is the note’s MIDI note-on velocity.

Exp. Velocity (Exponential Velocity)

This is MIDI note-on velocity through an exponential curve. The curve means that low velocities won’t have very much effect, and the difference between two lower velocity values won’t be very noticeable.

On the other hand, high velocities produce increasingly greater effects, and the difference between any two higher velocity values will be more pronounced.

Poly After

Polyphonic aftertouch allows a different aftertouch value for each note. This can be received from external MIDI devices or generated by the internal sequencer. The microSTATION keyboard itself does not generate poly aftertouch, however.

After Touch

The effect will be applied by channel aftertouch messages from the microSTATION’s sequence data or received from MIDI IN.

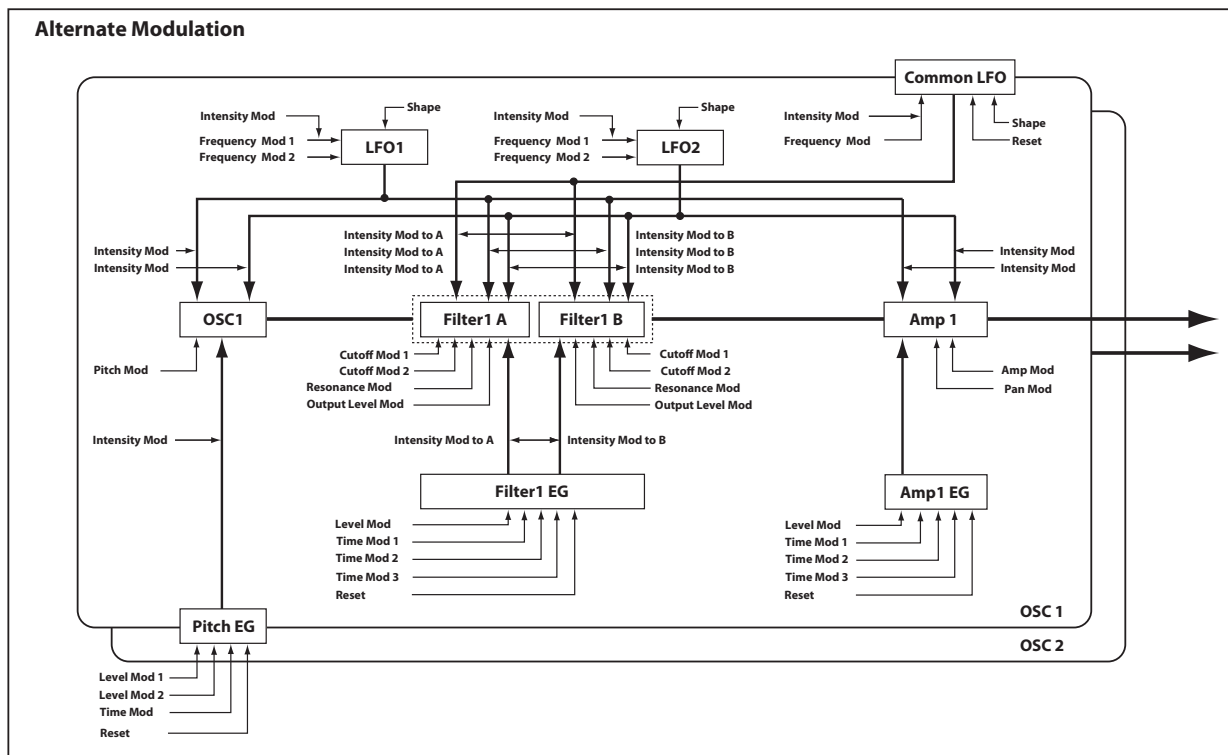

JS X

This is the horizontal movement of the main joystick. It also receives MIDI Pitchbend.

JS+Y: CC#01

This is the vertical movement of the main joystick, upwards from the center. It also receives MIDI CC#01 (mod wheel).

JS-Y: CC#02

This is the vertical movement of the main joystick, downwards from the center. It also receives MIDI CC#02 (breath controller).

JS +Y & AT/2 (Joy Stick +Y & After Touch/2)

The effect will be controlled by the joystick +Y (Vertical upward) and by aftertouch. In this case, the effect of aftertouch will be only half of the specified intensity.

JS -Y & AT/2 (Joy Stick -Y & After Touch/2)

The effect will be controlled by the joystick -Y (Vertical downward) and by aftertouch. In this case, the effect of aftertouch will be only half of the specified intensity.

Pedal: CC#04 (Foot Pedal: CC#04)

If you want to use the assignable foot pedal as an AMS, set the PEDAL/SW "Pd1" (p.65) to Foot Pedal ("Foot Pedal Assign" on page 296)).

This lets you use a foot pedal connected to DAMPER/PEDAL/SW to control parameters.

KnobMod 1: #17 (Realtime Knob Modulation 1: CC#17)

KnobMod 2: #19 (Realtime Knob Modulation 2: CC#19)

KnobMod 3: #20 (Realtime Knob Modulation 3: CC#20)

KnobMod 4: #21 (Realtime Knob Modulation 4: CC#21)

If you want to use Realtime Control B mode knobs 1-4 as AMS, you'll need to make "Knob Assign" settings individually for each program, combination, and song; set "Knob 1B" to Knob Mod. 1 (CC#17), "Knob 2B" to Knob Mod. 2 (CC#19), "Knob 3B" to Knob Mod. 3 (CC#20), and "Knob 4B" to Knob Mod. 4 (CC#21) ("Realtime Control Knob 1-4 Assign" on page 294).

Set Realtime Control to B mode, and then operate knobs 1-4 to apply modulation.

If the AMS intensity is a positive (+) value, setting the knob in the center will apply an AMS effect of 0. Turning the knob toward the right of center will apply an effect in the positive direction, and turning it toward the left will apply an effect in the negative direction. (With negative (-) values, the effect will apply in the opposite direction.)

KnobMod1[+] (Realtime Knob Modulation1[+])

KnobMod2[+] (Realtime Knob Modulation2[+])

KnobMod3[+] (Realtime Knob Modulation3[+])

KnobMod4[+] (Realtime Knob Modulation4[+])

With these AMS sources, the knob position and the direction of the resulting change are different than KnobMod1: #17-KnobMod4: #21. If AMS intensity is set to a positive (+) value, rotating the knob to the far left will produce an AMS effect of 0. Rotating the knob toward the right will apply change only in the positive direction. (If the intensity is set to a negative value, the result will be the opposite.)

Damper: #64

This is the Damper pedal, also sometimes called the sustain pedal. It corresponds to MIDI CC#64.

When using Korg's optional half-damper pedal, the DS-1H, this AMS source is continuous—not just on/off.

Portamento SW: #65

This is the MIDI portamento switch (CC#65), which also enables and disables portamento.

Sostenuto: #66

This is the MIDI sostenuto pedal (CC#66).

Soft: CC#67

This is the MIDI oft pedal (CC#67).

SW 1: CC#80 (SW 1 Modulation: CC#80)

MIDI control change (CC#80)

SW 2: CC#81 (SW 2 Modulation: CC#81)

MIDI control change (CC#81)

Foot SW: #82 (Foot SW: CC#82)

If you want to use the assignable foot switch as an AMS, set the PEDAL/SW "SW" (p.65) to Foot switch ("Foot Switch Assign" on page 295)).

This lets you use a foot switch connected to DAMPER/PEDAL/SW to control parameters.

MIDI: CC#83

MIDI control change (CC#83)

Tempo

This lets you use the system tempo as a modulation source. 120 is the center, for a value of 0; 60BPM is -99, and 240BPM is +99.

Note that this is different from actually syncing to tempo; for that purpose, use the dedicated synchronization functions for the LFOs, effects, etc.

Gate1

Gate1+Damper

Gate 1 is triggered by a new note after all notes have been released, such as at the beginning of a phrase. Gate 1+Damper is similar, except that it is triggered by a new note-on after all notes and the damper are released.

You can use this to reset the Common LFO. For instance, to create an effect similar to the per-voice LFO and Step Sequencer's "Key Sync Off" setting, use **Gate 1 + Damper** as the reset source.

Gate2

Gate2+Damper

Gate 2 is similar to Gate 1, but it triggers with every new note-on, even in the middle of a legato phrase. Gate2+Damper includes the damper pedal in the equation, as shown in the diagram below.

When used as a reset controller for Common LFO, Gate2 and Gate2+Damper will have the same effect.

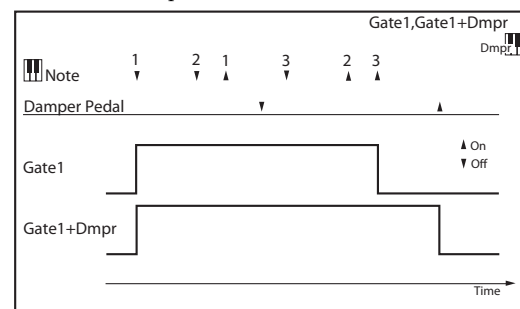

Alternate Modulation settings

When you use an AMS (Alternate Modulation Source), the modulation destination will be affected as shown in the table below.

By using alternate modulation, you can create complex systems of modulation in which EG, LFO, keyboard tracks, and controllers work together.

- You can apply complex change to an LFO or EG, for example by using the pitch/filter/amp EG to control the frequency or intensity of an LFO that modulates the pitch/filter/amp, or by using LFO2 to control the frequency of LFO1.

- The tone, EG, and LFO etc. can be controlled not only by key velocity or the joystick, but also from a knob, or pedal etc.
- Panning can be controlled in realtime from a controller, EG, or LFO etc.
- You can use the filter EG to control pitch or volume at the same time that it controls the filter.
- Controllers etc. can be used to control EG levels or times. This lets you shape the EG in realtime.
- Filter/amp keyboard tracking or note number can be used to control the EG or LFO according to the keyboard pitch that is played.
- Pitch, tone, EG or LFO can be controlled by the tempo of the arpeggiator and/or sequencer.

AMS operations and their result

AMS source & value range		Amp EG 0...+99	Pitch & Filter EGs -99...0...+99	LFO1 & 2 -99...0...+99	Common LFO -99...0...+99	Filter & Amp Key Track -99...0...+99	Common Key Track 1 & 2 -99...0...+99	Note Number C-1...C4...C9	EXT(+/-) *1 -Max...0...+Max EXT (Tempo) *2 ♩...60.00...120.00...240.00...	EXT(+) *3 0...127
Parameter	AMS Intensity									
Pitch	(+12.00)	0...+1 Octave	-1...0...+1 Octaves (Filter EG as AMS; dedicated parameter for Pitch EG)	Dedicated parameter	-1...0...+1 Octaves	-	-	Dedicated parameter	-1...0...+1 Octaves	0...+1 Octave
Pitch EG Int.	(+12.00)	-	Dedicated parameter for Pitch EG	-	-1...0...+1 Octaves	-	-	-1...0...+1 Octaves	-1...0...+1 Octaves	0...+1 Octave
Pitch LFO1/2 Int.	(+12.00)	0...+1 Octave	-1...0...+1 Octaves	-	-1...0...+1 Octaves	-	-	-1...0...+1 Octaves	-1...0...+1 Octaves	0...+1 Octave
Filter Frequency	(+99)	0...+10 Octaves	-10...0...+10 Octaves (Pitch EG as AMS; dedicated parameter for Filter EG)	Dedicated parameter	Dedicated parameter for Filter KTrk	-10...0...+10 Octaves	-	-	-10...0...+10 Octaves	0...+10 Octaves
Filter Resonance	(+99)	0...+99	-	-	-99...0...+99	-	-	-	-99...0...+99	0...+99
Filter EG Int.	(+99)	-	Dedicated parameter for Filter EG	-	-99...0...+99	-	-	-	-99...0...+99	0...+99
Filter LFO1/2 Int.	(+99)	0...+99	-99...0...+99	-	-99...0...+99	-	-	-99...0...+99	-99...0...+99	0...+99
Filter Output Level A/B	(+99)	0...+99	-	-	-99...0...+99	-	-	-	-99...0...+99	0...+99
Amp	(+99)	Dedicated parameter	0...1x...8x	Dedicated parameter	0...1x...8x	Dedicated parameter for Amp KTrk	-	-	0...1x...8x	1x...8x
Amp LFO1/2 Int.	(+99)	0...+99	-99...0...+99	-	-99...0...+99	-	-	-99...0...+99	-99...0...+99	0...+99
Pan	(+50)	0...+63	-	-	-63...0...+63	-	-	-	-63...0...+63	0...+63
EG Level	(+66)	-	-	-	-99...0...+99	-	-	-	-99...0...+99	0...+99
EG Time	(+49)	-	-	-	1/64x...1x...64x	-	-	-	1/64x...1x...64x	1x...64x
LFO 1 Frequency *4	(+99)	1x...64x	1/64x...1x...64x (LFO2 only)	-	1/64x...1x...64x	-	-	-	1/64x...1x...64x	1x...64x
LFO 2 Frequency *4	(+99)	1x...64x	-	-	1/64x...1x...64x	-	-	-	1/64x...1x...64x	1x...64x
Common LFO Frequency *4	(+99)	-	-	-	1/64x...1x...64x	-	-	-	1/64x...1x...64x	1x...64x
LFO 1 Shape	(+99)	0...+99	-99...0...+99 (LFO2 only)	-	-99...0...+99	-	-	-	-99...0...+99	0...+99
LFO 2 Shape	(+99)	0...+99	-	-	-99...0...+99	-	-	-	-99...0...+99	0...+99
Common LFO Shape	(+99)	-	-	-	-99...0...+99	-	-	-	-99...0...+99	0...+99

Notes for the table

- *1 EXT(+/-): JS X, Ribbon:CC#16, Knob Mod1 (CC#17), Knob Mod2 (CC#19), Knob Mod3 (CC#20), Knob Mod4 (CC#21)
- *2 When Tempo is selected as an AMS source, the base value is $\downarrow=120.00$.
For example if the Pitch AMS is set to Tempo, and Intensity is set to 12.00, doubling the tempo value ($\downarrow=120.00 \rightarrow 240.00$) will raise the pitch one octave, and halving the tempo ($\downarrow=120.00 \rightarrow 60.00$) will lower the pitch one octave. The stated modulation results are for tempo values between 60bpm and 240bpm. As the tempo decreases from 60 to 0bpm, AMS modulation will have increasingly negative effects; as it increases from 240 to 250bpm, modulation will have increasingly positive effects.
- *3 EXT(+): Velocity, Exp. Velocity, Poly After, After Touch, JS+Y:CC#01, JS-Y:CC#02, JS+Y & AT/2, JS-Y & AT/2, Pedal:CC#04, ValueSlider:#18, Knob Mod1[+], Knob Mod2 [+], Knob Mod3[+], Knob Mod4[+], Damper:CC#64, PortamentoSW:CC#65, Sostenu:CC#66, Soft:CC#67, SW1:CC#80, SW2:CC#81, MIDI:CC#83, MIDI:CC#85, MIDI:CC#86, MIDI:CC#87, MIDI:CC#88.
- *4 It is possible to control LFO Frequency by using Tempo AMS and Intensity. However if you use the Frequency MIDI/Tempo Sync function (p.119), the LFO frequency can be synchronized to the tempo and note value.

The effects of AMS on various parameters, and example applications

We'll describe some examples of using alternate modulation.

Note: The parameter names and values used in these explanations can be viewed and edited in microSTATION Editor/Plug-In Editor.

Pitch (p.91)

Pitch can be controlled by the Common LFO, filter/amp EG, controllers, or tempo etc.

- If you select Filter EG or Amp EG as the AMS and set Intensity to +12.00, the pitch will change up to ± 1 octave in synchronization with the EG.
- If you select Tempo as the AMS and set Intensity to +12.00, doubling the tempo (based on $\downarrow=120.00$) will raise the pitch one octave, and halving the tempo will lower the pitch one octave.

Pitch EG (p.96)

Pitch EG intensity can be controlled by the Common LFO, keyboard tracking, controllers, or tempo.

- If you select JS +Y:CC#01 as the AMS and set Intensity to +12.00, moving the joystick in the +Y direction will gradually increase the effect of the Pitch EG to a maximum of ± 1 octave. If Intensity has a negative value, the effect of the Pitch EG will be inverted.

LFO 1/2 (p.118)

Pitch modulation intensity of the LFO1/2 can be controlled by the Common LFO, an EG, keyboard tracking, controllers, or tempo etc.

- If you select EG as the AMS, the pitch change width of LFO modulation etc. can be controlled in synchronization with the level changes of the EG. With positive (+) settings of Intensity, the vibrato effect will gradually deepen as the EG level rises, or gradually lessen as the EG level decreases. With negative (-) settings of Intensity, the LFO phase will be inverted.
- If a controller such as a foot switch connected to the DAMPER/PEDAL/SW jack is selected as "AMS," you can apply a pitch/vibrato effect by turning on the foot switch only when you want the effect.

Filter (Cutoff) Frequency (p.100)

The cutoff frequency of filter A/B can be controlled by the pitch/amp EG, Common keyboard tracking, controllers, or tempo. Use the Filter Modulation 1 (2) page Filter A/B Modulation (p.102) to set AMS and Intensity for Filter A or B.

- If you select JS X as the AMS1 or AMS2 and set Intensity to a positive (+) value, moving the joystick toward the right will raise the cutoff frequency, and moving it toward the left will lower the cutoff frequency. Negative (-) settings will have the opposite effect.
- If you select the same controller as an AMS1 or AMS2 and set separate intensities for Filter A (Low Pass Filter) Intensity and Filter B (High Pass Filter) Intensity, you can use a single controller to simultaneously control the cutoff frequencies of both filters.

Resonance (p.101)

You can use the EG, LFO, keyboard tracking, controllers, or tempo etc. to control the resonance level.

- If you select Filter KTrk or Amp KTrk as the AMS, you can use the filter or amp keyboard tracking settings to control the resonance level. For example if the amp keyboard tracking parameters Ramp BtmLo and Ramp HiTop are set to positive (+) values, Amp KTrk is selected as the AMS, and Intensity it set to a positive (+) value, playing toward either end of the keyboard will cause amp keyboard tracking to increase the volume, and AMS to raise the resonance level.
- You can select a controller as the AMS, and apply resonance when desired by using the controller.
- You can select Common LFO, LFO1 or 2 as the AMS, and use the LFO to control the resonance level.

Output (p.101)

You can use the EG, LFO, keyboard tracking, controllers, or tempo etc. to control the output level of Filter A/B.

- Set filter routing ("Routing") to Parallel, and specify the desired filter type for each filter A and B. Choose LFO as "AMS" for filters A and B, and set "Intensity" to +99 and -99 respectively. This allows the LFO to cyclically crossfade between the outputs of filters A and B.

Filter EG Intensity (p.104)

Filter EG intensity can be controlled by the Common LFO, Common keyboard tracking, a controller or tempo etc. You can use Intensity to A and Intensity to B to independently specify the intensity for Filter A and B.

- If you select JS -Y (CC#02) as the AMS and set Intensity to A and Intensity to B to a positive (+) value, moving the joystick in the -Y direction will gradually increase the effect of the Filter EG. If you set Intensity to A and Intensity to B to a negative (-) value, the effect of the Filter EG will be inverted.
- If you select JS X as the AMS and set Intensity to A and Intensity to B to a positive (+) value, moving the joystick toward the right will gradually increase the effect of the Filter EG. Moving the joystick toward the left will gradually increase the effect of the Filter EG with an inverted phase.

Filter LFO1/2 Intensity (p.105)

The LFO 1/2 filter modulation intensity can be controlled by the EG, Common LFO, keyboard tracking, controller, or tempo etc. You can use Intensity to A and Intensity to B to independently specify the intensity for Filter A and B.

- If you select EG as the AMS, the auto-wah effect produced by LFO modulation will be controlled by the changes in EG level. If you set Intensity to A and Intensity to B to a positive (+) value, the wah effect will deepen as the EG level rises, and will lessen as the EG level falls. With negative (-) values of Intensity to A and Intensity to B, the phase of the LFO will be inverted.
- If a controller such as a foot switch connected to the DAMPER/PEDAL/SW jack is selected as "AMS," you can apply the auto-wah effect by turning on the foot switch only when you want the effect.

Filter Common LFO (p.120)

You can use the EG, LFO, keyboard tracking, controllers, or tempo etc. to control the Common LFO filter modulation intensity. You can use Intensity to A and Intensity to B to specify the intensity separately for Filter A and B.

- You can set AMS to a controller, and use the controller only when desired to control the depth of the filter sweep produced by the Common LFO.

Amp (p.110)

The volume can be controlled by the pitch/filter EG, Common LFO, controllers, or tempo etc.

- If an EG or controller that changes with a positive (+) value (EXT(+)) is selected as the AMS, setting the "Intensity" to +99 will allow you to increase the volume to a maximum of eight times that of the current volume.
- If an EG, LFO, or controller that changes with a ± value (Pitch EG, Filter EG, LFO, KT, EXT(+/-)) is selected as the AMS, setting the Intensity to +99 will allow you to increase the volume to a maximum of eight times that of the current volume (for positive (+) changes of the AMS), or to decrease the volume to zero (for negative (-) changes of the AMS).
- In addition to the time-variant changes in volume produced by the amp EG, you can also make the volume change in synchronization with the pitch/filter EG. Select Pitch EG or Filter EG as the AMS, and adjust Intensity. If you wish to cancel the effect of the Amp EG and use the pitch/filter EG to control the volume, set all levels of the Amp EG to +99.

Amp LFO1/2 Intensity (p.112)

The amp modulation intensity of LFO 1/2 can be controlled by the EG, Common LFO, keyboard tracking, controllers, or tempo etc.

- If you select EG as the AMS, the depth of the tremolo effect produced by LFO modulation will change in synchronization with the changes in EG level. If you set "Intensity" to a positive (+) value, the tremolo effect will deepen as the EG level rises, and lessen as the EG level falls. If "Intensity" is set to a negative (-) value, the phase of the LFO will be inverted.
- If a foot switch connected to the DAMPER/PEDAL/SW jack is selected as "AMS," you can apply the tremolo effect by turning on the foot switch only when desired.

Pan (p.110)

The oscillator pan can be controlled by the EG, LFO, keyboard tracking, controllers, or tempo etc.

- If you select Note Number as the AMS and set "Intensity" to +50, panning will be controlled by the keyboard position: center at the C4 note, far right at C9 or above, and far left at C-1 or below.
- If EG is selected as the AMS, the oscillator pan will be controlled in synchronization with the changes in EG

level. If "Intensity" is set to a positive (+) value, the pan will move toward the right as the EG level increases, and toward the left as the EG level decreases. If "Intensity" is set to a negative (-) value, the opposite effect will occur.

EG Reset —

Pitch EG (p.98)

Filter EG (p.109)

Amp EG (p.115)

You can use the EG, LFO, keyboard tracking, controllers, or tempo etc. to control EG Reset. Use the Threshold setting to specify the AMS value at which result will occur.

- By setting AMS to Common LFO, you can reset the envelope cyclically at the interval of the Common LFO. The result is just as if the shape specified by the envelope were being used as a special LFO.
- You can reset the envelope by setting AMS to a controller such as JS+Y, and using the controller when desired, producing a one-shot filter envelope sweep.

EG Level —

Pitch EG (p.97)

Filter EG (p.107)

Amp EG (p.113)

EG levels can be controlled by the Common LFO, keyboard tracking, controllers, or tempo etc.

You can specify an Intensity value for each EG segment (Start, Attack, Break). If you set the Intensity value to +66, you will be able to control the respective level over a maximum range of ±99.

- Set AMS to Velocity for Amp EG Level Modulation, Intensity Start to +00, Attack to +66, and Break to -66. Set all Amp EG levels to +00. As you play with increasing velocity, the EG levels will change more greatly. At the maximum velocity, the Start Level will stay at +00, but the Attack Level will change to +99 and the Break Level will change to -99.

EG Time —

Pitch EG (p.96)

Filter EG (p.108)

Amp EG (p.113)

EG times can be controlled by the Common LFO, keyboard tracking, controllers, or tempo etc.

You can specify an Intensity value for each EG segment (Attack, Decay, Slope, Release). EG times are determined by the Alternate Modulation value when the preceding point is reached. For example, the Alternate Modulation value at the moment the envelope reaches the attack level will determine the decay time.

If Intensity is set to a value of 8, 17, 25, 33, 41, or 49, the corresponding time can be multiplied by a maximum of 2, 4, 8, 16, 32, or 64 times (or divided by 1/2, 1/4, 1/8, 1/16, 1/32, 1/64).

- Select JS+Y:CC#01 for AMS, and set AMS Intensity to +8, "At" to +, "Dc" to -, and "Sl" and "Rl" to 0. When you move the joystick in the +Y direction, the Attack Time will be lengthened by a maximum of 2 times. The Decay Time will be shortened by a maximum of 1/2. The Slope and Release times will not change.

LFO Frequency (p.117)

The frequency of LFO 1, 2 or Common LFO can be controlled by the EG, keyboard tracking, controllers, or tempo etc.

You can also use the LFO2 frequency to modulate LFO1, or use the Common LFO frequency to modulate LFO 1/2.

If Intensity is set to a value of 16, 33, 49, 66, 82, or 99, the corresponding frequency can be multiplied by a maximum of 2, 4, 8, 16, 32, or 64 times (or divided by 1/2, 1/4, 1/8, 1/16, 1/32, 1/64).

- Select JS +Y:CC#01 for “AMS,” and set “Intensity” to +16. When you move the joystick in the +Y direction, the LFO frequency will be increased by a maximum of 2 times. If you set “Intensity” to -16 and move the joystick in the +Y direction, the LFO frequency will be decreased by up to 1/2.

LFO Frequency AMS Intensity (p.118)

You can use the EG, keyboard tracking, controllers, or tempo etc. to control the intensity of the AMS that controls the frequency of the LFO 1, 2, or Common LFO.

For example if you’re using the pitch EG to modulate the LFO frequency, you could use a separate AMS to control the depth of this effect.

- If a foot switch connected to the DAMPER/PEDAL/SW jack is selected as “AMS,” the pitch EG will lightly modulate the LFO frequency when the foot switch is off; the pitch EG will deeply modulate the LFO frequency when the foot switch is on.

LFO Shape (p.117)

You can use a EG, keyboard tracking, controllers, or tempo etc. to control the shape of the LFO 1, 2, or Common LFO waveform. You can also use the LFO2 frequency to modulate LFO1, or use the Common LFO frequency to modulate LFO 1/2.

- You can control the LFO waveform by setting AMS to a controller such as JS+Y, and using the controller when desired.

Common LFO Reset (p.120)

You can use a controller or tempo etc. to reset the Common LFO.

- By setting AMS to Gate 1, you can make the Common LFO reset when a note is played from a state in which all notes are off. For example, this will ensure that a filter sweep always starts from the same place.

You can set “AMS” to a controller such as JS+Y: CC#01, and use the controller when you want to reset the LFO.

Dynamic Modulation Source (Dmod)

You can control certain effect parameters using the joystick, realtime control knobs, etc. “on the fly.”

These parameters can also be controlled by the sequencer.

Controlling effects in this way is referred to as Dynamic Modulation. For example, you can use joystick to speed up the LFO of the chorus and flanger, or to sweep a wah effect. This lets you take full advantage of the effects as part of the expressive potential of your instrument.

Most of the parameters for dynamic modulation consist of parameter values for Source and Amount. The Source field selects the modulation source, and Amount sets the modulation intensity. When the Source is at its maximum value (for instance, when JS+Y is moved all the way up), the actual degree of the effect will be the parameter value plus the Amount.

Example:

“Wet/Dry” 10:90, “Source” JS+Y:#01, “Amount” +50

In this case, the effect balance will normally be 10:90, and moving the joystick in the +Y direction will gradually increase the proportion of the effect sound. When the joystick is moved all the way in the +Y direction, the effect balance will be 60:40.

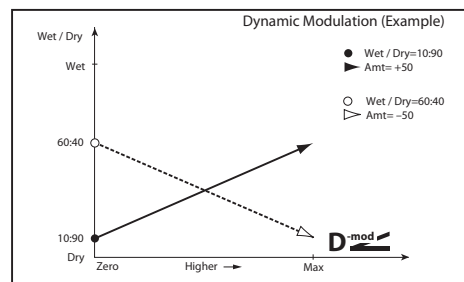

See the individual effects descriptions for explanations of other dynamic modulation parameters. Parameters which can be controlled through dynamic modulation are marked by the **D^{mod}** symbol.

MIDI In Program mode, dynamic modulation is always controlled via the global MIDI Channel.

In Combination and Sequencer modes, dynamic modulation is controlled via the MIDI channel independently specified by the “Ch (Control Change)” for IFX1-5, MFX1, 2, and TFX.

Note: Most dynamic modulation settings can be edited only by using the included editor; they cannot be edited from the microSTATION itself.

Dmod List (Dynamic Modulation Source List)

Off	dynamic modulation is not used
Gate1	note on/off p.293
Gate1+Dmpr	note on + damper on/off p.293
Gate2	note on/off (retrigger) p.293
Gate2+Dmpr	note on + damper on/off (retrigger) p.293
Note Numbr	note number
Velocity	velocity
Exp Velocity	exponential velocity p.293
After Touch	aftertouch (Channel After Touch) reception
JS X	joystick X (horizontal) direction
JS+Y: #01	joystick +Y (Vertical upward) direction (CC#01)
JS-Y: #02	joystick -Y (Vertical downward) direction (CC#02)
Pedal: #04	assignable foot pedal (CC#04) p.293

FXCtrl1: #12	MIDI effect control 1 (CC#12)
FXCtrl2: #13	MIDI effect control 2 (CC#13)
CC#16 (Rbn)	MIDI Control Change (MIDI Control Change CC#16)
CC#18 (Vol)	value slider (CC#18)
KnobM1 #17	realtime control B knob (knob modulation 1 CC#17) ☞ p.293
KnobM2 #19	realtime control B knob (knob modulation 2 CC#19) ☞ p.293
KnobM3 #20	realtime control B knob (knob modulation 3 CC#20) ☞ p.293
KnobM4 #21	realtime control B knob (knob modulation 4 CC#21) ☞ p.293
KnobM1 [+]	realtime control B knob 1 [+] ☞ p.293
KnobM2 [+]	realtime control B knob 2 [+] ☞ p.293
KnobM3 [+]	realtime control B knob 3 [+] ☞ p.293
KnobM4 [+]	realtime control B knob 4 [+] ☞ p.293
Damper #64	damper pedal (CC#64)
PrtaSW #65	portamento switch (CC#65)
Sostenu #66	sostenuto pedal (CC#66)
Soft #67	soft pedal (CC#67)
CC#80 (SW1)	MIDI Control Change (CC#80)
CC#81 (SW2)	MIDI Control Change (CC#81)
FootSW #82	assignable foot switch (CC#82) ☞ p.293
CC#83	MIDI Control Change (CC#83)
CC#85	MIDI Control Change (CC#85)
CC#86	MIDI Control Change (CC#86)
CC#87	MIDI Control Change (CC#87)
CC#88	MIDI Control Change (CC#88)
Tempo	tempo (internal clock or external MIDI clock tempo data) ☞ p.293

Gate1, Gate1+Dmpr (Gate1, Gate1+Damper)

The effect is at maximum during note-on, and will stop when all keys are released. With Gate1 + Damper, the effect will remain at maximum even after the keys are released, as long as the damper (sustain) pedal is pressed.

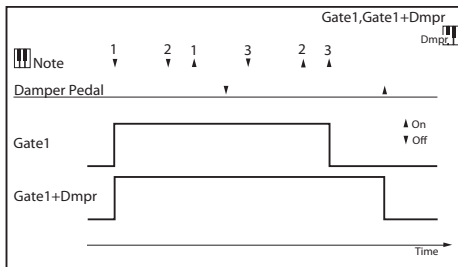

Gate2, Gate2+Dmpr (Gate2, Gate2+Damper)

This is essentially the same as for Gate 1 or Gate 1 + Dmpr. However when Gate 2 or Gate 2 + Damper are used as a dynamic modulation source for the EG of 075: St. Env. Flanger etc. or the AUTOFADE of 076: Stereo Vibrato, a trigger will occur at each note-on. (In the case of Gate 1 and Gate 1 + Dmpr, the trigger occurs only for the first note-on.)

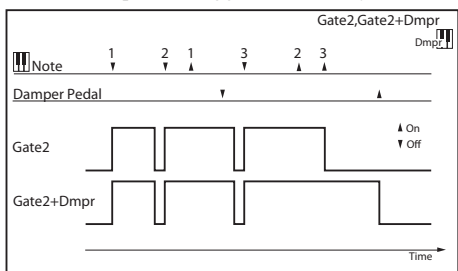

Exp Vel (Exponential Velocity)

Modulation will be applied exponentially according to the velocity value. Weak velocity values will produce little effect, but the effect will increase rapidly as the velocity values rise.

Pedal #04 (Foot Pedal: CC#04)

If you wish to use the assignable foot pedal as a dynamic modulation source, set PEDAL/SW "Pdl" (Globo/Media: Controllers) to Foot Pedal. (☞ "Foot Pedal Assign" on page 296)

A foot controller etc. connected to the ASSIGNABLE DAMPER/PEDAL/SW jack can be used to control an effect.

KnobM1 #17 (Knob Modulation1: CC#17)

KnobM2 #19 (Knob Modulation2: CC#19)

KnobM3 #20 (Knob Modulation3: CC#20)

KnobM4 #21 (Knob Modulation4: CC#21)

If you want to use knobs 1–4 as a dynamic modulation source when the Realtime Control B mode is selected, use the Knob Assign Realtime Control Knob Assign parameter to assign "Knob 1B" to Knob Mod.1 (CC#17), "Knob 2B" to Knob Mod.2 (CC#19), "Knob 3B" to Knob Mod.3 (CC#20), and "Knob 4B" to Knob Mod.4 (CC#21) for each program, combination, or song. (☞ "Realtime Control Knob 1–4 Assign" on page 294)

Then select the Realtime Control B mode, and you can use knobs 1–4 to control the effects.

If the knob is set to the 12 o'clock position, the resulting effect as a dynamic modulation source will be zero. If the Amount is a positive (+) value, rotating the knob toward the right will apply positive change, and rotating it toward the left it will produce negative change. (With negative values, the result will be the opposite.)

KnobM1 [+] (Knob Modulation1 [+])

KnobM2 [+] (Knob Modulation2 [+])

KnobM3 [+] (Knob Modulation3 [+])

KnobM4 [+] (Knob Modulation4 [+])

The knob position and the direction of the resulting change are different than Knob Mod.1 (CC#17)–Knob Mod.4 (CC#21). If Amount is set to a positive (+) value, rotating the knob to the far left all the way will produce an effect of 0 as the dynamic modulation source all the way will apply change only in the positive direction. (If the Amount is set to a negative value, the result will be the opposite.)

FootSW #82 (Foot Switch: CC#82)

If you wish to use an assignable foot switch as a dynamic modulation source, set PEDAL/SW "SW" (Globo/Media: Controllers) to Foot Switch (CC#82) (☞ "Foot Switch Assign" on page 295)

The effect will be controlled when you use a foot switch etc. connected to the ASSIGNABLE DAMPER/PEDAL/SW jack.

Tempo

The resulting modulation will be zero at 120 BPM, the maximum positive value at 300 BPM, and the maximum negative value at 40 BPM.

Realtime Control Knob 1–4 Assign

The following functions can be assigned as the function of knobs 1–4 when the Realtime controls B mode is selected.

Knob assignments are saved separately with each Program, Combination, and Song.

For more information, see:

- Programs: Knob Assign [p.9](#)
- Combinations: Knob Assign [p.23](#)
- Sequencer mode: Knob Assign [p.45](#)

List of Knobs 1–4 assignments

The following functions can be assigned to Realtime Control knobs 1–4.

Off

This setting disables the slider.

Knob Mod1–4 (CC#s17, 19, 20, 21)

These settings let you use the knob as an AMS or Dmod source. Note that you'll also need to assign the knob to control the desired parameter within the Program or Effect.

Master Vol

This controls the overall volume, and transmits the Universal System Exclusive Master Volume message [FOH, 7FH, nn, 04, 01, vv, mm, F7H]. You can use this to adjust the volumes of all Tracks or Timbres at the same time, while preserving their relative balance.

Porta. Time (CC#05)

This controls the portamento time. Note that a different controller, CC#65, turns Portamento on and off.

Volume (CC#07)

Controls the volume, and transmits CC#7.

Post IFX Pan (CC#08)

Controls the panning after the last Insert Effect in the chain, and transmits CC#8.

Pan (CC#10)

Controls stereo pan, and transmits CC#10.

Expression (CC#11)

Expression is a secondary volume control, which you can use to scale level without affecting the main volume settings or CC#7 values.

When used one at a time, MIDI Volume and Expression affect level in exactly the same way: a MIDI value of 127 is equal to Program's main Level setting, and lower values reduce the volume.

If both CC#7 and CC#11 are used simultaneously, the one with the lower value determines the maximum volume, and the one with the higher value scales down from that maximum.

FX Ctrl 1 & 2 (CC#s12 & 13)

These assignments are intended for Effect Dynamic Modulation (Dmod). Note that you'll also need to assign FX Control 1 or 2 to control the desired parameter within the Effect.

Cutoff (CC#74)

This scales the cutoff frequency of all of the filters at once. For instance, it affects both Filters A and B.

Resonance (CC#71)

This scales the resonance of all of the filters at once. For instance, it affects both Filters A and B.

Filt EG Int (CC#79)

This scales the effect of the Filter EG on the cutoff frequency. It affects all of the filters at once; for instance, it affects both Filters A and B.

F/A Attack (CC#73)

This scales the attack times of the Filter and Amp EGs, along with other related parameters.

When the CC value is above 64, this also affects the Amp EG's Start and Attack Levels, Start Level AMS, and Attack Time AMS, as described below:

Between values of 65 and 80, the Start Level, Start Level AMS, and Attack Time AMS will change from their programmed values to 0. Over the same range, the Attack Level will change from its programmed value to 99.

F/A Decay (CC#75)

This scales the decay and slope times of the Filter and Amp EGs.

F/A Sustain (CC#70)

This scales the sustain levels of the Filter and Amp EGs.

F/A Release (CC#72)

This scales the release times of the Filter and Amp EGs.

P. LFO1 Spd (CC#76)

This scales LFO1's frequency.

P. LFO1 Dep (CC#77)

This scales the effect of LFO1 on the Pitch.

P. LFO1 Dly (CC#78)

This scales LFO1's fade-in time.

CC#80(SW 1) & CC#81(SW 2)

Normally, these are used for the two assignable switches - but you can assign them to the sliders instead, if you like.

Foot Switch (CC#82)

You can use this general-purpose controller as an AMS or Dmod source. Note that you'll also need to assign FootSW (CC#82) to control the desired parameter within the Program or Effect.

MIDI CC#83 (CC#83)

You can use this general-purpose controller as an AMS or Dmod source. Note that you'll also need to assign MIDI CC#83 to control the desired parameter within the Program or Effect.

MFx Send 1 & 2 (CC#s 93 & 91)

These control the send levels to Master Effects 1 and 2, respectively.

CC#s 93 and 91 actually control send levels in two different places: the sends directly from the Program OSC and the send levels of the last Insert Effect in the chain which matches the CC's MIDI channel.

MIDI CC#00–95 and 102–119

These settings let you transmit any MIDI CC, except for registered and non-registered parameters (CCs 96–101). If you choose a CC which is used by AMS, Dmod, or the standard CC routings, then it will affect the corresponding microSTATION parameters.

 When the Realtime Control A mode is selected, the function of knobs 1–4 is fixed.

Knob 1–A: CUTOFF (Filter Cutoff: CC#74)

This scales the cutoff frequency of all of the filters at once.

Knob 2–A: RESONANCE (Filter Resonance: CC#71)

This scales the resonance of all of the filters at once.

Knob 3–A: EG INTENSITY (Filter EG Intensity: CC#79)

This scales the effect of the Filter EG on the cutoff frequency.

Knob 4–A: EG RELEASE (Filter, Amplifier EG Release: CC#72)

This scales the release times of the Filter and Amp EGs.

Foot Switch Assign

Here you can specify the function of an assignable switch (separately sold PS-1) connected to the DAMPER/PEDAL/SW jack.

- Set the Global/Media: Controllers - PEDAL/SW “Type” to Switch, and use the “Sw” parameter (p.65) to specify the function.

MIDI If you select a function that includes a CC#, that MIDI control change message will be transmitted each time the function is turned on/off (Off: 0, On: 127). If you select RTC Knob 1B–Knob4B, the MIDI control change message specified by the “Knob Assign” setting of each mode will be transmitted each time the function is turned on/off (Off: 0, On: 127).

List of Foot Switch assignments

Off

This setting disables the switch.

Foot Switch (CC#82)

This lets you use the switch as an AMS or Dmod source. Note that you’ll also need to assign Foot SW (CC#82) to control the desired parameter within the Program or Effect.

Porta. SW (CC#65)

This controls portamento on/off. For more information, please see “Portamento switch (CC#65) [Bn, 41, vv]” on page 304.

Sostenuto (CC#66)

This controls the sostenuto effect, which holds only the notes being played at the moment that the foot switch is turned on.

Soft (CC#67)

Turns the soft pedal effect on and off.

Damper (CC#64)

Turns the damper pedal effect on and off.

Program Up

This lets you use the switch to increment the current Program or Combination number, for hands-free patch changes. Note that this is only active while on the PROG PLAY or COMBI PLAY, respectively. When you use this control, the microSTATION will also transmit the corresponding MIDI Program Change and Bank Select messages.

Program Down

This decrements the current Program or Combination number, for hands-free patch changes. For more information, please see “Program Up,” above.

Value Inc

Using the foot switch will produce the same function as pressing the ▲ button.

Value Dec

Using the foot switch will produce the same function as pressing the ▼ button.

Song S/S

The foot switch will control sequencer start/stop. Simultaneously, a MIDI Start or Stop message will be transmitted.

PunchIn/Out

If SEQ: REC “M (Recording mode)” is set to MPI (Manual Punch In,) the switch can be used to punch-in and punch-out when recording on the sequencer.

Tap Tempo

The foot switch will control the system tempo in real-time.

ARP ON/OFF

The foot switch will turn the arpeggiator on/off.

ARP LATCH

The foot switch will turn the arpeggiator Latch.

JS+Y (CC#01)

The switch will control the effect produced by joystick movement in the +Y direction (Vertical upward).

JS–Y (CC#02)

The switch will control the effect produced by joystick movement in the –Y direction (Vertical downward).

RT Knob1–A...4–A, RT Knob1–B...4–B

Use the switch to control the effect of knobs 1–4 when the Realtime Control A or B mode is selected. (Foot switch “on” is equivalent to turning the knob to the far right; foot switch “off” is equivalent to turning the knob to the far left.)

ARP GATE

Use the switch to control the arpeggiator’s Gate. (Foot switch “on” is equivalent to turning the knob to the far right; foot switch “off” is equivalent to turning the knob to the far left.)

ARP VEL

Use the switch to control the arpeggiator’s Velocity. (Foot switch “on” is equivalent to turning the knob to the far right; foot switch “off” is equivalent to turning the knob to the far left.)

ARP SWING

Use the switch to control the arpeggiator’s Swing. (Foot switch “on” is equivalent to turning the knob to the far right; foot switch “off” is equivalent to turning the knob to the far left.)

Foot Pedal Assign

Here you can specify the function that will be controlled by an assignable pedal (separately sold XVP-10, EXP-2) connected to the DAMPER/PEDAL/SW jack.

- Set the Global/Media: Basic Controllers - PEDAL/SW “Type” to Pedal, and use the “Pd1” parameter (p.65) to specify the function.

MIDI Some of the assignments include MIDI CCs, which are transmitted whenever the slider is moved. Note that the MIDI CCs can still be received even if they are not assigned to a physical controller. If you select RT Knob 1-B – 4-B, the MIDI control change message specified by the Realtime Control Knob Assign settings in each mode will be transmitted.

List of Foot Pedal assignments

Off

This setting disables the pedal.

Master Vol

This controls the overall volume, and transmits the Universal System Exclusive Master Volume message [F0H, 7FH, nn, 04, 01, vv, mm, F7H]. You can use this to adjust the volumes of all Tracks or Timbres at the same time, while preserving their relative balance.

If an external MIDI device connected to the microSTATION supports this message, its overall system volume can be controlled.

Foot Pedal (CC#04)

You can use this general-purpose controller as an AMS or Dmod source. Note that you’ll also need to assign Foot Pedal (CC#04) to control the desired parameter within the Program or Effect.

Porta. Time (CC#05)

Controls the speed at which portamento will change the pitch.

Volume (CC#07)

Control the volume of a Program, Combination, or of a MIDI track in Sequencer modes.

PostIFXPan (CC#08)

Control the pan after passing through the Insert Effect.

Pan (CC#10)

Control the pan of a Program, of a timbre in a Combination, or of a MIDI track in Sequencer modes.

Expression (CC#11)

Expression is a secondary volume control, which you can use to scale level without affecting the main volume settings or CC#7 values.

For more information, please see “Expression (CC#11)” on page 294.

FX Ctrl 1 & 2 (CC#s12 & 13)

These assignments are intended for Effect Dynamic Modulation (Dmod). Note that you’ll also need to assign FX Ctrl1 or 2 to control the desired parameter within the Effect.

MFX Send 1 & 2 (CC#s 93 & 91)

These control the send levels to Master Effects 1 and 2, respectively.

CC#s 93 and 91 actually control send levels in two different places: the sends directly from the Program OSC and the send levels of the last Insert Effect in the chain which matches the CC’s MIDI channel.

JS+Y (CC#01)

This duplicates the function of JS+Y. Whatever JS+Y is assigned to control, the pedal will control as well.

JS-Y (CC#02)

This duplicates the function of JS-Y. Whatever JS-Y is assigned to control, the pedal will control as well.

CC#16(Rbn)

You can use this general-purpose controller as an AMS or Dmod source. Note that you’ll also need to assign Ribbon (CC#16) to control the desired parameter within the Program or Effect.

RT Knob1-A...4-A, RT Knob1-B...4-B

Use the pedal to control the effect of knobs 1–4 when the Realtime Control A or B mode is selected.

ARP GATE

Use the pedal to control the arpeggiator’s Gate.

ARP VEL

Use the pedal to control the arpeggiator’s Velocity.

ARP SWING

Use the pedal to control the arpeggiator’s Swing.

MIDI transmission when the microSTATION's controllers are used

controllers are used, and the AMS (alternate modulation source) or DMS (dynamic modulation source) that corresponds to each MIDI message.

indicates a fixed function, and * indicates an assignable function.

The following tables show the relation between the MIDI messages that are transmitted when the microSTATION's

MIDI messages	Joystick	Realtime Knob 1-A...4-A	Realtime Knob 1-B...4-B	ARP					Damper	Foot Switch	Foot Pedal	Available for AMS	Available for Dmod
				On/Off	LATCH On/Off	Knob1 (GATE)	Knob2 (VELOCITY)	Knob3 (SWING)					
Note-off												*	*
Note-on (note number)												*	*
Note-on (velocity)												*	*
Poly aftertouch												*	*
CC# 0 Bank select (MSB)			*	*	*	*	*	*				*	*
1 Modulation 1		#+Y	*	*	*	*	*	*	*	*	*	*	*
2 Modulation 2		#(-Y)	*	*	*	*	*	*	*	*	*	*	*
3 -			*	*	*	*	*	*	*	*	*	*	*
4 Foot controller			*	*	*	*	*	*	*	*	*	*	*
5 Portamento time			*	*	*	*	*	*	*	*	*	*	*
6 Data entry (MSB)			*	*	*	*	*	*	*	*	*	*	*
7 Volume			*	*	*	*	*	*	*	*	*	*	*
8 Post Insert Effect panpot			*	*	*	*	*	*	*	*	*	*	*
9 -			*	*	*	*	*	*	*	*	*	*	*
10 Panpot			*	*	*	*	*	*	*	*	*	*	*
11 Expression			*	*	*	*	*	*	*	*	*	*	*
12 Effect control 1			*	*	*	*	*	*	*	*	*	*	*
13 Effect control 2			*	*	*	*	*	*	*	*	*	*	*
14 ARP On/Off control			*	*	*	*	*	*	*	*(1)	*	*	*
15 -			*	*	*	*	*	*	*	*	*	*	*
16 Controller (CC#16)			*	*	*	*	*	*	*	*	*	*	*
17 Knob modulation 5			*	*	*	*	*	*	*	*	*	*	*
18 Controller (CC#18)			*	*	*	*	*	*	*	*	*	*	*
19 Knob modulation 6			*	*	*	*	*	*	*	*	*	*	*
20 Knob modulation 7			*	*	*	*	*	*	*	*	*	*	*
21 Knob modulation 8			*	*	*	*	*	*	*	*	*	*	*
22 ARP-GATE control			*	*	*	*	*(*)	*	*	*(1)	*(1)	*	*
23 ARP-VELOCITY control			*	*	*	*	*	*(*)	*	*(1)	*(1)	*	*
24 ARP-LENGTH control			*	*	*	*	*	*(*)	*	*(1)	*(1)	*	*
25 -			*	*	*	*	*	*	*	*	*	*	*
26 -			*	*	*	*	*	*	*	*	*	*	*
27 -			*	*	*	*	*	*	*	*	*	*	*
28 -			*	*	*	*	*	*	*	*	*	*	*
29 -			*	*	*	*	*	*	*	*	*	*	*
30 -			*	*	*	*	*	*	*	*	*	*	*
31 ARP-LATCH			*	*	*	*	*(*)	*	*	*	*	*	*
32 Bank select (LSB)			*	*	*	*	*	*	*	*	*	*	*
33..37 -			*	*	*	*	*	*	*	*	*	*	*
38 Data entry (LSB)			*	*	*	*	*	*	*	*	*	*	*
39..63 -			*	*	*	*	*	*	*	*	*	*	*
64 Damper			*	*	*	*	*	*	#	*	*	*	*
65 Portamento On/Off			*	*	*	*	*	*	*	*	*	*	*
66 Sostenuto			*	*	*	*	*	*	*	*	*	*	*
67 Soft pedal			*	*	*	*	*	*	*	*	*	*	*
68..69 -			*	*	*	*	*	*	*	*	*	*	*
70 Sustain level			*	*	*	*	*	*	*	*	*	*	*
71 Filter resonance level		# (Knob2)	*	*	*	*	*	*	*	*	*	*	*
72 Release time		# (Knob4)	*	*	*	*	*	*	*	*	*	*	*
73 Attack time			*	*	*	*	*	*	*	*	*	*	*
74 Filter cutoff frequency		# (Knob1)	*	*	*	*	*	*	*	*	*	*	*
75 Decay time			*	*	*	*	*	*	*	*	*	*	*
76 LFO1 speed			*	*	*	*	*	*	*	*	*	*	*
77 LFO1 depth (pitch)			*	*	*	*	*	*	*	*	*	*	*
78 LFO1 delay			*	*	*	*	*	*	*	*	*	*	*
79 Filter EG intensity		# (Knob3)	*	*	*	*	*	*	*	*	*	*	*
80 Controller (CC#80)			*	*	*	*	*	*	*	*	*	*	*
81 Controller (CC#81)			*	*	*	*	*	*	*	*	*	*	*
82 Foot switch On/Off			*	*	*	*	*	*	*	*	*	*	*
83 Controller (CC#83)			*	*	*	*	*	*	*	*	*	*	*
84 -			*	*	*	*	*	*	*	*	*	*	*
85 Controller (CC#85)			*	*	*	*	*	*	*	*	*	*	*
86 Controller (CC#86)			*	*	*	*	*	*	*	*	*	*	*
87 Controller (CC#87)			*	*	*	*	*	*	*	*	*	*	*
88 Controller (CC#88)			*	*	*	*	*	*	*	*	*	*	*
89..90 -			*	*	*	*	*	*	*	*	*	*	*
91 Effect depth 1 (send 2 level)			*	*	*	*	*	*	*	*	*	*	*
92 Effect depth 2 (IFX 1-5 On/Off)			*	*	*	*	*	*	*	*	*	*	*
93 Effect depth 3 (send 1 level)			*	*	*	*	*	*	*	*	*	*	*
94 Effect depth 4 (MFX 1, 2 On/Off)			*	*	*	*	*	*	*	*	*	*	*
95 Effect depth 5 (TFX 1, 2 On/Off)			*	*	*	*	*	*	*	*	*	*	*
96 Data increment			*	*	*	*	*	*	*	*	*	*	*
97 Data decrement			*	*	*	*	*	*	*	*	*	*	*
98 NRPN(LSB)			*	*	*	*	*	*	*	*	*	*	*
99 NRPN(MSB)			*	*	*	*	*	*	*	*	*	*	*
100 RPN(LSB)			*	*	*	*	*	*	*	*	*	*	*
0: Bend range			*	*	*	*	*	*	*	*	*	*	*
1: Fine tune			*	*	*	*	*	*	*	*	*	*	*
2: Coarse tune			*	*	*	*	*	*	*	*	*	*	*
101 RPN(MSB) 0			*	*	*	*	*	*	*	*	*	*	*
102 -			*	*	*	*	*	*	*	*	*	*	*
103 -			*	*	*	*	*	*	*	*	*	*	*
104 -			*	*	*	*	*	*	*	*	*	*	*
105 -			*	*	*	*	*	*	*	*	*	*	*
106 -			*	*	*	*	*	*	*	*	*	*	*
107 -			*	*	*	*	*	*	*	*	*	*	*
108 -			*	*	*	*	*	*	*	*	*	*	*
109 -			*	*	*	*	*	*	*	*	*	*	*
110 -			*	*	*	*	*	*	*	*	*	*	*
111 -			*	*	*	*	*	*	*	*	*	*	*
112 -			*	*	*	*	*	*	*	*	*	*	*
113 -			*	*	*	*	*	*	*	*	*	*	*
114 -			*	*	*	*	*	*	*	*	*	*	*
115 -			*	*	*	*	*	*	*	*	*	*	*
116 -			*	*	*	*	*	*	*	*	*	*	*
117 -			*	*	*	*	*	*	*	*	*	*	*
118 -			*	*	*	*	*	*	*	*	*	*	*
119 -			*	*	*	*	*	*	*	*	*	*	*
Program change			*	*	*	*	*	*	*	*	*	*	*
Channel aftertouch			*	*	*	*	*	*	*	*	*	*	*

MIDI messages	Joystick	Realtime Knob 1-A...4-A	Realtime Knob 1-B...4-B	ARP			Knob2 (VELOCITY)	Knob3 (SWING)	Damper	Foot Switch	Foot Pedal	Available for AMS	Available for Dmod
				On/Off	LATCH On/Off	Knob1 (GATE)							
Pitch Bend	# (X)											*	*
Universal exclusive													
Master volume			*								*		
Master balance													
Master fine tune													
Master coarse tune													

(1):When a arpeggiator controller is assigned to a CC# indicated by [*] (Global/Media: Controllers– ARP RTC CC#)

*: Assignable

[*]: The ARP Controllers can be assigned to CC#00–119.

CC#s indicated by [*] will be assigned automatically when you use the Global/Media command Reset ARP CC# with the CC Default setting.

The CC Default settings are the CC#s recommended as the CC# for each of these controllers. Normally you should use these settings when assigning CC#s.

When you operate a controller on the microSTATION, the corresponding or assigned control change will be transmitted. The exception is that when you move the joystick in the X (horizontal) direction, pitch bend change messages will be transmitted.

If you've selected RTC Knob1B–Knob4B in "SW" (Foot Switch function) or "Pdl" (Foot Pedal function), the MIDI control change message specified by the Knob Assign setting of each mode will be transmitted.

If you select ARP ON/OFF, ARP LATCH, ARP GATE, ARP VELOCITY, or ARP SWING, the MIDI control change message specified by the Global/Media: Controllers - ARP RTC CC# setting will be transmitted.

Operations in each mode are described below. (Here we will explain only control changes, but the same applies for pitch bend change.)

Program mode

When one of the microSTATION's controllers is used, a control change message will be transmitted on the global MIDI channel (p.60).

 If the Realtime Control B mode is selected, and knobs 1–4 or the assignable pedal are assigned to Master Volume, the universal exclusive message Master Volume will be transmitted.

Combination mode

When one of the microSTATION's controllers is used, a control change message will be transmitted on the global MIDI channel (p.60).

Simultaneously, the message will also be transmitted on the MIDI channel (MIDI Channel p.20) of any timbre whose Status (p.20) is EXT or EX2.

When one of the microSTATION's controllers is used, its effect will apply to any timbre whose Status is INT and whose MIDI Channel setting is either Gch or the same as the global MIDI channel.

 In the case of Master Volume, the universal exclusive message Master Volume will be transmitted only on the global MIDI channel.

 You can use the MIDI Filter settings (p.22) to enable or disable control changes and controllers for each timbre. If the setting is On, the above operations will be enabled.

Effect dynamic modulation can be controlled when the "Ch" (p.25) setting for IFX1–5, MFX1, 2, or TFX is either set to Gch or to the same channel as the global MIDI channel. (In the case of All Routed, control is possible on the MIDI channel of any routed timbre.)

Sequencer mode

When you use a controller on the microSTATION, the effect will apply to the MIDI track 1–16 that's selected by the front panel function 01–16 buttons.

If the Status (p.38) of the track selected by Track Select is EXT, EX2, or BTH, a control change message will be transmitted on the MIDI channel specified by MIDI Channel (p.39).

If the Status is INT or BTH, operating one of the microSTATION's controllers will affect only that MIDI track. Simultaneously, the same effect will also apply to any MIDI track with the same MIDI Channel setting.

 In the case of Master Volume, the universal exclusive message Master Volume will be transmitted.

 You can use the MIDI Filter settings (p.40) to enable or disable control changes and controllers for each timbre. If the setting is On, the operations effective for a Status of INT or BTH will be enabled. Tracks whose Status is EXT, EX2, or BTH will transmit control changes regardless of this setting.

Effect dynamic modulation is possible if the "Ch" setting (p.46) of the respective insert effect 1–5, master effects 1 and 2, or total effect matches the MIDI channel of the track that's selected by the front panel function 01–16 buttons. (In the case of the All Routed setting, control is possible using all MIDI channels of the routed tracks.)

If one of the microSTATION's controllers is operated during realtime recording, the corresponding or assigned control change will be recorded.

microSTATION and MIDI CCs

Responses to standard MIDI controllers

The following table shows how the microSTATION responds to MIDI control change messages, and the rela-

tion between settings and controller movements on the microSTATION.

CC#	Control	Value	Function
0	Bank select (MSB)	0...127	bank select message MSB *1
1	Modulation 1	0...127	corresponds to joystick movement in the +Y direction (Vertical upward)
2	Modulation 2	0...127	corresponds to joystick movement in the -Y direction (Vertical downward)
3	-	-	-
4	Foot controller	0...127	corresponds to when the assignable pedal function is set to Foot Pedal
5	Portamento time	0...127	portamento time
6	Data entry (MSB)	0...127	MSB of RPN and NRPN data *2
7	Volume	0...127	volume *3
8	Post Insert Effect panpot	0...127	pan after the Insert Effect
9	-	-	-
10	Panpot	0...127	pan
11	Expression	0...127	volume *3
12	Effect control 1	0...127	corresponds to effect dynamic control source FX Control1 (☞p.305)
13	Effect control 2	0...127	corresponds to effect dynamic control source FX Control2 (☞p.305)
14	ARP ON/OFF control	0...63(Off), 64...127(On)	equivalent to on/off when CC#14 is assigned to the ARP ON/OFF button *7
15	-	-	-
16	Controller (CC#16)	0...127	for controlling AMS or Dmod
17	Knob modulation 1	0...127	corresponds to when the realtime control knob function is set to Knob Mod.1
18	Controller (CC#18)	0...127	for controlling AMS or Dmod *8
19	Knob modulation 2	0...127	corresponds to when the realtime control knob function is set to Knob Mod.2
20	Knob modulation 3	0...127	corresponds to when the realtime control knob function is set to Knob Mod.3
21	Knob modulation 4	0...127	corresponds to when the realtime control knob function is set to Knob Mod.4
22	ARP-GATE control	0...127	equivalent to when CC#22 is assigned to arpeggio control knob 1 (GATE) *7
23	ARP-VELOCITY control	0...127	equivalent to when CC#23 is assigned to arpeggio control knob 2 (VELOCITY) *7
24	ARP-SWING control	0...127	equivalent to when CC#24 is assigned to arpeggio control knob 3 (SWING) *7
25	-	-	- *7
26...30	-	-	-
31	ARP LATCH control	0...63(Off), 64...127(On)	equivalent to on/off when CC#14 is assigned to the ARP LTACH button *6
32	Bank select (LSB)	0...127	LSB of bank select message *1
33...37	-	-	-
38	Data entry (LSB)	0...127	LSB of RPN or NRPN data *2
39...63	-	-	-
64	Damper	0...127	damper effect
65	Portamento On/Off	0...63(Off), 64...127(On)	turn the portamento effect on/off
66	Sostenuto On/Off	0...63(Off), 64...127(On)	turn the sostenuto effect on/off
67	Soft	0...127	soft pedal effect
68...69	-	-	-
70	Sustain level	0...127	sustain levels of the filter EG and amp EG *4
71	Filter resonance level	0...127	resonance level of the filter *4
72	Release time	0...127	cutoff frequency of the high pass filter *4
73	Attack time	0...127	release times of the filter EG and amp EG *4

CC#	Control	Value	Function
74	Filter cutoff frequency	0...127	cutoff frequency of the low pass filter *4
75	Decay time	0...127	decay times/slope times of the filter EG and amp EG *4
76	LFO1 speed	0...127	LFO1 speed *4
77	LFO1 depth	0...127	pitch LFO1 intensity *4
78	LFO1 delay	0...127	LFO1 delay *4
79	Filter EG intensity	0...127	filter EG intensity *4
80	Controller (CC#80)	0...63(Off), 64...127(On)	for controlling AMS or Dmod
81	Controller (CC#81)	0...63(Off), 64...127(On)	for controlling AMS or Dmod
82	Foot switch On/Off	0...63(Off), 64...127(On)	corresponds to on/off when the function of the assignable foot switch is set to Foot SW
83	Controller (CC#83)	0...127	for controlling AMS or Dmod
84	–	–	–
85...88	Controller (CC#85...88)	0...127	for controlling AMS or Dmod
89, 90	–	–	–
91	Effect depth 1 (send 2 level)	0...127	send 2 level
92	Effect depth 2 (Insert Effect 1–5 On/Off)	0...63(Off), 64...127(On)	turn Insert effect 1...5 on/off *5
93	Effect depth 3 (send 1 level)	0...127	send 1 level
94	Effect depth 4 (master effect 1, 2 On/Off)	0...63(Off), 64...127(On)	master effect 1, 2 on/off *5
95	Effect depth 5 (total effect On/Off)	0...63(Off), 64...127(On)	total effect on/off *5
96	Data increment	0	
97	Data decrement	0	
98	NRPN(LSB)	–	LSB of NRPN
99	NRPN(MSB)	–	MSB of NRPN
100	RPN(LSB)	0	selects the pitch bend range *2
		1	controls Fine Tune *2
		2	controls Coarse Tune *2
101	RPN(MSB)	0	MSB of RPN
102... 109	–	–	–
110	–	–	–
111	–	–	–
112	–	–	–
113	–	–	–
114... 119	–	–	–

You can assign any control change number (CC#00–119) to the Realtime Control Knobs 1-B – 4-B. In this case, the transmitted values will all be 0...127.

You can assign any control change number (CC#00–119) to the ARP ON/OFF button, ARP LATCH button, and Realtime controls C mode knobs 1–4. In this case, ARP switches will transmit values of 0 (Off) or 127 (On), knobs 1–4 will transmit values of 0...127.

*1 In the microSTATION sequencer, bank select messages are normally specified as program change events. However in some cases this will be insufficient when you wish to change banks on an external device. In such cases, you can use CC#00 and CC#32 to specify the banks.

For information on the relation between bank select numbers and the banks of your external device, refer to the owner's manual for your external device.

*2 Unlike conventional control changes, pitch bend range, fine tune, and coarse tune settings are made using RPC (Registered Parameter Control) messages. In Program, Combination, and Sequencer modes, you can use RPC messages to control the bend range and tuning for each program, Timbre (Combination), or Track (Sequencer). The procedure is to use an RPN (Registered Parameter

Number) message to select the parameter that you wish to edit, and then use Data Entry to input a value for that parameter. To select the parameter, use CC#100 (with a value of 00...02) and CC#101 (with a value of 00). use CC#06 and CC#38 to enter the data.

The data entry values for each parameter and the corresponding settings are as follows.

RPN=0 (Pitch bend range)

CC#06	CC#38	Parameter value (Semitone steps)
00	00	0
01	00	+ 1
⋮	⋮	⋮
12	0	+12

RPN=1 (Fine tune)

CC#06	CC#38	Parameter value (1 cent steps)
32	00	-50
⋮	⋮	⋮
48	00	-25
⋮	⋮	⋮
64	00	0
⋮	⋮	⋮
96	00	+50

RPN=2 (Coarse tune)

CC#06	CC#38	Parameter value (Semitone steps)
40	00	-24
⋮	⋮	⋮
52	00	-12
⋮	⋮	⋮
64	00	0
⋮	⋮	⋮
88	00	+24

For example, if in Sequencer mode you wish to set a MIDI track that is receiving channel 1 to a transpose (coarse tuning) value of -12, you would first transmit [B0, 64, 02] (64H=CC#100) and [B0, 65, 00] (65H=CC#101) to the microSTATION to select the RPN coarse tune. Then you would set this to -12 by transmitting [B0, 06, 34] (06H=CC#6), 34H=52 (corresponds to -12), and [B0, 26, 00] (26H=CC#38, 00H=0).

- *3 The volume of the microSTATION is determined by multiplying the Volume (CC#07) with the Expression (CC#11). In Sequencer mode when you stop the song playback and return the location to the beginning of the track, the Volume will be set to the starting value, and the Expression will be set to the maximum value (127).
- *4 A value of 64 will correspond to the value specified by the program parameter. 0 is the minimum, and 127 is the maximum. Changing from 63-1 or from 65-126 will adjust the effect from the program parameter setting toward the minimum value or maximum value.

For details about the specific parameters controlled by these CCs, please see "Parameters controlled by MIDI CCs #70-79" on page 301

*5 Controlled on the global MIDI channel.

*6 If you assign a CC# to the ARP ON/OFF button, ARP LATCH button, and Realtime controls C mode knobs 1-4, and perform these operations on the microSTATION, the assigned CC# will be transmitted, and the microSTATION itself will also be controlled at the same time. If this message is received, the result will be the same as if the microSTATION itself had been operated.

The CC# settings for each knob and button are made in the Global/Media- Controllers, ARP RTC CC#. Use these settings if you need to assign control change messages, for example when you want to record switch operations on the internal sequencer or an external MIDI sequencer, or to control the arpeggiator from an external MIDI device.

Each knob and button can be assigned to any desired MIDI control change message CC#00-119, but normally you will choose the Global/Media- command Reset ARP CC# and use the CC Default settings.

This table shows the operations for the CC Default settings. The CC Default settings are the CC#s recommended for use with these controllers. Normally, you will assign these CC#s.

Parameters controlled by MIDI CCs #70-79

CC#70-79 correspond to the microSTATION's program parameters listed below.

In Program mode, the corresponding program parameters will be temporarily edited when CC#70-79 messages are received on the global MIDI channel (p.60), when knobs 1-4 are operated when the Realtime Control A mode is selected, or when knobs 1-4 are operated when assigned to CC#70-79 with the Realtime Control B mode.

In most cases, you can use the Write Program command to save the edited values, over-writing the previous Program settings.

 In Combination and Sequencer modes, you can use these CCs to temporarily edit the parameters for all Timbres or Tracks on a given MIDI channel. However, edits made in this way cannot be saved back into a Program.

CC#	Internal parameters controlled by the CC
70 (Sustain level)	Filter/Amp EG Sustain Level (p.6, p.107, p.113) Amp EG 1/2 Sustain (p.6, p.113)
71 (Filter resonance)	Filter A/B, 1/2 Resonance (p.5, p.101)
72 (Release time)	Filter EG 1/2 Release (p.6, p.107), Amp EG 1/2 Release (p.6, p.114)
73 (Attack time)	EG Times: Filter EG 1/2 Attack (p.6, p.107) Amp EG 1/2 Attack (p.6, p.113) Amp EG 1/2 Time Modulation: Attack (p.114) EG Levels: Amp EG 1/2 Level Start (p.113) Amp EG 1/2 Level Attack (p.113) Amp EG 1/2 Level Modulation: Start (p.114)
74 (Filter cutoff frequency)	Filter A/B, 1/2 Frequency (p.100)
75 (Decay time)	Filter EG 1/2 Decay (p.6, p.108), Filter EG 1/2 Slope (p.108) Amp EG 1/2 Decay (p.113), Amp EG 1/2 Slope (p.113)
76 (LFO1 speed)	LFO 1 Frequency (p.117)
77 (LFO1 Pitch intensity)	Pitch LFO1 Intensity (p.6, p.93)
78 (LFO1 delay)	LFO 1 Delay (p.118)
79 (Filter EG intensity)	Filter EG 1/2 Intensity to A (p.104), Filter EG 1/2 Intensity to B (p.104)

MIDI applications

About MIDI

MIDI stands for Musical Instrument Digital Interface, and is a world-wide standard for exchanging various types of musical data between electronic musical instruments and computers. When MIDI cables are used to connect two or more MIDI devices, performance data can be exchanged between the devices, even if they were made by different manufacturers.

Settings when connected to a MIDI device or computer

Here we will explain the settings you'll make on the microSTATION when connecting it to another device.

The "Convert Position" setting

The microSTATION's settings "Transpose," "Vel Curve," and "AT Curve" (p.57, p.182) respectively allow you to adjust the transposition, velocity sensitivity, and aftertouch (received only from the internal sequencer or from MIDI IN) sensitivity.

 The aftertouch curve is applied only to data received from the internal sequencer or from MIDI IN. The "AT Curve" setting does nothing if "Convrt" (p.61) is PreMIDI.

The effect that these settings will have on the internal sequencer and on the MIDI data that is transmitted and received will depend on "Convrt" (p.61) setting.

- If you want to control an external MIDI tone generator from the microSTATION, set "Convrt" to PreMIDI. The various settings listed above will be reflected in the MIDI data that is transmitted. These settings will also be reflected in the data that is recorded on the internal sequencer. Incoming MIDI data will be handled with settings equivalent to Key Transpose 0, Velocity Curve 4, and After Touch Curve 3.
- When controlling the microSTATION's tone generator from an external MIDI device, select PostMIDI. The above-listed settings will affect the MIDI data that is received. These settings will also affect the data that is played back from the internal sequencer. Outgoing MIDI data will be handled with settings equivalent to Key Transpose 0, and Velocity Curve 4.

Local Control On settings

If you've connected the microSTATION to a computer or external MIDI sequencer and want to use the "echo-back" from that device to play the microSTATION, turn echo-back on for your external MIDI sequencer or computer (so that the data it receives at MIDI IN will be retransmitted from MIDI OUT), and turn off the microSTATION's local control setting (so that the microSTATION's keyboard section and sound generator will be internally disconnected).

When you play the keyboard of the microSTATION, the musical data will be transmitted to the external MIDI sequencer or computer, and then echoed back to play the microSTATION's tone generator. In other words, by turning Local Control OFF, you can prevent notes from being

sounded in duplicate, as would otherwise occur if a note were sounded by the microSTATION's own keyboard and again by the data that was echoed-back.

If the arpeggiator function is on, playing the microSTATION's keyboard will not cause the arpeggiator to operate, and only the musical data produced by playing the keyboard will be transmitted. The arpeggiator will operate only in response to the notes that are echoed-back and received at MIDI IN. In this way, turning off Local Control prevents the arpeggiator from operating in duplicate.

Use this setting when you wish to record on the external MIDI sequencer or computer only the notes that trigger the arpeggiator, and to use the echoed-back notes to operate the arpeggiator while monitoring your recording or during playback.

If you want the note data produced by the arpeggiator to be recorded on the external sequencer/computer, set Local Control on, and turn off the Echo Back setting of the external sequencer/computer.

When using the microSTATION by itself, leave Local Control turned on. (If this is off when the microSTATION is used by itself, playing the keyboard will not produce sound.)

Messages transmitted and received by the microSTATION

In the text below, [...] indicates hexadecimal notation.

MIDI channels

MIDI messages can be exchanged when the transmitting and receiving devices are set to the same MIDI channel. MIDI uses sixteen channels, numbered 1-16. The way in which channels are handled will differ depending on the mode.

Program mode

- The global MIDI channel is the basic channel that the microSTATION uses for MIDI transmission/reception, and is set by MIDI Channel (p.60, p.184).

Combination mode

- The global MIDI channel is used to transmit/ receive messages for selecting a combination and turning effects on/off, and to transmit/receive exclusive data.
- Each timbre will transmit/receive MIDI data on the MIDI Channel (p.20, p.145) that is specified for that timbre.
- The Ch MIDI channel specified for each effect (p.25, p.155) is used to control dynamic modulation of the insert/master/total effect, the pan following the insert effect, and send 1 and 2.
- When you use the keyboard or controllers of the microSTATION, messages will be transmitted on the global MIDI channel, and will also be transmitted on the MIDI channel of any timbre whose Status (p.20, p.145) is set to EXT or EX2.
- Channel messages will be received if they match the MIDI channel of a timbre whose Status is set to INT.

Sequencer mode

- The global MIDI channel is used to transmit/ receive exclusive data and for messages that switch effects on/off.

- MIDI data transmission/reception for each MIDI track will occur on the MIDI channel specified for each MIDI track by MIDI Channel (p.39, p.166).
- The MIDI channel specified for each effect by the “Ch” parameter (p.46, p.173) is used to control dynamic modulation of the insert/master/total effect, the pan following the insert effect, and send 1 and 2.
- When you use the keyboard or controllers of the microSTATION, MIDI data will be transmitted on the MIDI channel of the MIDI track selected by the front panel function 01–16 buttons. However, the data will be transmitted only for MIDI tracks whose “Status” is BTH, EXT, or EX2.
- When the sequencer is played back, musical data of MIDI tracks whose Status is BTH, EXT, or EX2 will be transmitted on the specified MIDI channels.
- MIDI tracks whose Status is INT or BTH will receive channel messages of the matching MIDI channel. For more information, please see “Status” on page 38, 166 and “MIDI Channel” on page 39, 166.

Note on/off

Note-on [9n, kk, vv]

Note-off [8n, kk, vv]

(n: channel, kk: note number, vv: velocity)

When you play a note on the microSTATION’s keyboard, it will transmit note-on/off messages.

When the arpeggiator is running, note-on/off messages generated by the arpeggiator are transmitted. If Local is Off, note-on/off messages generated by the arpeggiator will not be transmitted. See “Local Control On settings” on page 302. However, most instruments do not receive or transmit note-off velocity, and neither does the microSTATION.

Program changes / Bank select

When you select a program on the microSTATION, you’ll use a number that starts with 1 for each category shown in the display. MIDI uses bank numbers and program numbers to select programs. You can view this bank number and program number in the following way.

Access a page in which you can select programs, press the NUM LOCK button to turn Num Lock on, and then press the ENTER (14) button.

The bank will be indicated as A, B, C, or D. The corresponding MIDI bank select number will depend on the “Bank Map” setting (p.59, p.182).

Changing the program/bank

Program change [Cn, pp]

(n: channel, pp: program number that allows 128 sounds to be selected)

- Programs 000–127 in banks A–E correspond to program changes [Cn, 00]–[Cn, 7F].
- Programs 001–128 in banks GM, g(1), g(2), g(3), g(4), g(5), g(6), g(7), g(8), g(9), and g(d) correspond to program changes [Cn, 00]–[Cn, 7F].

Bank select MSB (CC#0) [Bn, 00, mm]

Bank select LSB (CC#32) [Bn, 20, bb]

(n: channel, mm: bank number upper byte, bb: bank number lower byte)

- The internal banks that correspond to each bank select number will depend on the Bank Map setting (p.59, p.182). KORG is the default setting.

Simply receiving a Bank Select message will not cause the program or bank to change. The program or bank will actually change when a Program Change message is received.

Program mode

- In PROG PLAY, these messages will transmit and receive program change and bank select operations.

Combination, Sequencer modes

- Program change and bank select messages can be received on the MIDI channel specified for each timbre/MIDI track to select programs on that timbre/track.
- When you select a combination, program change and bank select messages will be transmitted by timbres whose Status is EXT or EX2. In Sequencer mode, program change or bank select messages will be transmitted by tracks whose Status is BTH, EXT, or EX2 when you select the Program Select parameter (p.36, p.163), when you select a song, or when you return to the beginning of a measure.
- In Combination and Sequencer modes, transmission/reception can be switched on/off for each timbre/track. See “Enable Program Change” on page 22, 40, 150, and Global/Media: SEQ MIDI Out “Trk” on page 62, 184.

Selecting combinations

You can use program change and bank select messages to select combinations in the same way that you select programs.

- Combinations 000–127 in banks A–C correspond to program changes [Cn, 00]–[Cn, 7F].
- Similarly as for program banks, the internal banks that correspond to each bank select number will depend on the Bank Map setting. For more information, please see “Bank Map” on page 59, 182.

In COMBI PLAY, program change and bank select messages are transmitted/received on the global MIDI channel. They are not received in COMBI EDIT.

All program changes can be turned off in MIDI Filter (p.63, p.185)

As needed, you can independently turn all program changes on/off, specify whether or not incoming messages will be able to change combinations, and turn reception/transmission of bank select messages on/off.

- If Combination Change (p.63, p.185) is off, the combination will not change even if a program change on the global MIDI channel is received in COMBI PLAY. In this case, the program of the timbre that matches the MIDI channel of the received message will change.
- If Bank Change (p.63, p.185) is off, bank select messages will not be transmitted or received.

Aftertouch

Channel aftertouch [Dn, vv]

(n: channel, vv: value)

When this message is received, the aftertouch effect will be applied. The assigned alternate modulation or dynamic modulation effect will also be applied.

 The keyboard of the microSTATION itself cannot transmit aftertouch. Aftertouch can be received only from the internal sequencer or from MIDI IN.

Aftertouch reception for the entire instrument can be turned on/off in Enable After Touch (p.63, p.185).

In Combination and Sequencer modes, aftertouch can be turned on/off independently for each timbre/track.

Polyphonic aftertouch [An, kk, vv]

(n: channel, kk: note number, vv: value)

There is another type of aftertouch called Polyphonic Key Pressure, which allows aftertouch to be applied independently for individual keys. This message can be used as an alternate modulation source, but cannot be transmitted by the microSTATION's keyboard. In order to use this message, it will have to be received from an external device, or recorded on your sequencer.

The aftertouch mentioned in this manual refers to Channel After Touch.

Pitch bend

Pitch bend change [En, bb, mm]

(n: channel, bb: lower byte of the value, mm: upper byte of the value, together expressing a value of 16,384 steps where 8,192 [bb, mm = 00H, 40H] is the center value)

When the microSTATION's joystick is moved in the X axis (left/right), a pitch bend effect will be applied, and pitch bender messages will also be transmitted. When these messages are received, a pitch bend effect will be applied.

The range of pitch change that is produced by pitch bend messages can also be adjusted via MIDI. (See "Changing the pitch bend range" on page 308.)

Control change

[Bn, cc, vv]

Transmitted and received as (n: channel, cc: control change no., vv: value)

For more information, please see "MIDI transmission when the microSTATION's controllers are used" on page 297 and "microSTATION and MIDI CCs" on page 299.

- Control changes can be turned on/off as a whole in "Enable Control Change" (p.63, p.185).
- In Combination and Sequencer modes, the MIDI Filter settings allow transmission/reception of control changes to be individually turned on/off for each timbre/track. For the assignable controllers (Realtime Control Knob 1-B - 4-B, and Foot Pedal/Switch), MIDI filter settings will apply to the control change number where each controller is assigned. Other Control Change applies to control changes that are not covered by the items of the other check boxes (p.150, p.169).

Note: You can select MIDI CC#00-CC#119 for knobs 1-4 when the Realtime Control B mode is selected.

Although you can select MIDI CC#00-CC#119 for the ARP Controllers, you will normally use the default settings that are assigned when you use the command "Reset ARP CC#" with CC Default Setting, and ARP Controllers SW - ARP ON/OFF at CC#014, SW - LATCH ON/OFF at CC#031, KNOB1 - ARP GATE at CC#022, KNOB2 - ARP VELOCITY at CC#023, KNOB3 - ARP SWING at CC#024.

Selecting program/combination banks

Bank select (CC#00, CC#32)

Technically, Bank Select is a controller. In practice, however, it is a component of Program Change.

For more information, please see "Program changes / Bank select" on page 303.

Using the joystick to apply modulation

Modulation 1 depth (CC#01) [Bn, 01, vv]

When you move the microSTATION's joystick in the +Y direction (Vertical upward), Modulation 1 Depth messages will be transmitted. When these messages are received, the same effect will be applied as when the microSTATION's joystick is used. Normally this will apply a vibrato effect (pitch LFO).

- In Combination and Sequencer modes, transmission/reception can be turned on/off for each timbre/track. ("JS+Y" p.22, p.41, p.150, p.169)

Modulation 2 depth (CC#02) [Bn, 02, vv]

When you move the microSTATION's joystick in the -Y direction (Vertical downward), Modulation 2 Depth messages will be transmitted. When these messages are received, the same effect will be applied as when the microSTATION's joystick is used. Normally this will apply a wah effect (filter LFO).

- In Combination and Sequencer modes, transmission/reception can be turned on/off for each timbre/track. ("JS-Y" p.22, p.41, p.150, p.169)

Other manufacturers use this message for other purposes (e.g., breath controller, etc.)

Controlling portamento

Portamento time (CC#05) [Bn, 05, vv]

If you assign the above CC# to an Assignable Pedal or knobs 1-4 when the Realtime Control B mode is selected, rotating that knob will transmit Portamento Time messages, and will modify the speed at which the portamento pitch changes. When this message is received, the result will be the same as when the controller is used.

Portamento switch (CC#65) [Bn, 41, vv]

When the above CC# is assigned to the Assignable Switch, using that switch will transmit vv=127 [7F] for ON or vv=0 [00] for OFF, and the portamento effect will be switched on/off. When this message is received, the result will be the same as when the controller is used. (vv of 63 [3F] or less will be OFF, and 64 [40] or greater will be ON.) ("Foot Switch Assign" on page 295)

- In Combination and Sequencer modes, transmission/reception of this message can be turned on/off independently for each timbre/track ("Enable Portamento SW" p.150, p.169).
- In Sequencer mode, portamento time/switch messages will be transmitted by each track whose "Status" is BTH, EXT, or EX2 when you set "Portamento," re-select a song or SMF, or return to the beginning of a measure. For more information, please see "Portamento" on page 39, 166.

Controlling volume

Volume (CC#07) [Bn, 07, vv]

When the above CC# is assigned to the Assignable Pedal or knobs 1–4 when the Realtime Control B mode is selected, using that controller will transmit Volume messages, and the volume will change. When this message is received, the result will be the same as when the controller is used.

Expression (CC#11) [Bn, 0B, vv]

When the CC# above is assigned to the Assignable Pedal or knobs 1–4 when the Realtime Control B mode is selected, using that controller will transmit Expression messages, and the volume will change. When this message is received, the result will be the same as when the controller is used.

The volume of the microSTATION is determined by multiplying the value of the Volume message with the value of the Expression message.

If adjusting the Volume message does not increase the volume as you expect, or if there is no sound, transmit MIDI messages from an external device to reset the value of the Expression message (set vv to 127).

Note: In Sequencer mode, this will be reset when the Location of the song is moved to 001:01.000.

- In Combination mode, Volume messages will be transmitted by each timbre whose “Status” is EXT or EX2 when you re-select the combination.
- When you change the “Volume” setting in Sequencer mode, or when you re-select the song or return to the beginning of the song in Sequencer mode, volume messages will be transmitted by each track whose “Status” is BTH, EXT, or EX2.

See “Trk (Track MIDI Out)” on page 62, 184.

Note: Regardless of the Status settings, re-selecting a song, or returning to the beginning will reset the internal Volume value to the value specified by each track (the starting settings), and will reset the Expression value to the maximum.

Note: This message can be used to control the volume of each MIDI track. Normally, you will include a Volume message in the MIDI track setting data (the settings at the beginning of the track) to set the initial volume, and use Expression to create changes in dynamics as the song progresses.

By using the universal exclusive Master Volume message, you can adjust the overall volume without changing the volume balance between timbres or tracks. (See “About system exclusive messages” on page 308.)

Controlling pan (stereo position)

Pan (CC#10) [Bn, 0A, vv]

(vv: value, where 00 is far left, 64 is center, and 127 is far right)

When the CC# above is assigned to the Assignable Pedal or knobs 1–4 when the Realtime Control B mode is selected, using that controller will transmit Pan messages, and the panning will change. When this message is received, the result will be the same as when the controller is used.

When you set the “Pan” in Sequencer mode, or when you re-select the song or return to the beginning of the measure in Sequencer mode, Panpot messages (except for RND) will be transmitted by each track whose “Status” is BTH, EXT, or EX2.

See “Pan” on page 37, 163, “Trk (Track MIDI Out)” on page 62, 184.

Post insert effect pan (CC#08) [Bn, 08, vv]

(vv: value, where 00 is far left, 64 is center, and 127 is far right)

When the above CC# is assigned to the Assignable Pedal or knobs 1–4 when the Realtime Control B mode is selected, using that controller will transmit Post Insert Effect Panpot messages, and the panning of the sound following the insert effect will change. When this message is received, the result will be the same as when the controller is used.

In Program mode, this message is transmitted/received on the global MIDI channel. In Combination, and Sequencer modes, this message is transmitted/received on the MIDI channel specified for each insert effect.

When you set Pan(CC#8) in Sequencer mode, or when you re-select the song or return to the beginning of the measure in Sequencer mode, Post Insert Effect Panpot messages will be transmitted by each track whose “Status” is BTH, EXT, or EX2.

For more information, please see “IFX1, IFX2, IFX3, IFX4, IFX5” on page 25.

Controlling effects

Effect control 1 (CC#12) [Bn, 0C, vv]

Effect control 2 (CC#13) [Bn, 0D, vv]

When the above CC# is assigned to the Assignable Pedal or knobs 1–4 when the Realtime Control B mode is selected, using that controller will transmit Effect Control 1/2 messages, and the specified dynamic modulation will be controlled. When this message is received, the result will be the same as when the controller is using.

Although various types of control change can be selected as dynamic modulation sources, Effect Control 1 (CC#12) and 2 (CC#13) are dedicated for dynamic modulation.

Effect 1 depth (Send 2) (CC#91) [Bn, 5B, vv]

Effect 3 depth (Send 1) (CC#93) [Bn, 5D, vv]

When the CC# above is assigned to the Assignable Pedal or Realtime Control knobs 1–4, using that controller will transmit Effect 1 Depth (Send 2) or Effect 3 Depth (Send 1) messages, and the send level 1 or 2 to the master effects MFX1 or MFX2 will be controlled respectively. When this message is received, the result will be the same as when the controller is used.

On the corresponding MIDI channels, this will simultaneously control the timbre/track setting as well as the setting following the Insert Effect.

- In Combination, and Sequencer modes, the actual send level of the timbre/track is determined by multiplying this value with the send 1/2 settings for each oscillator. (See “Send 1 (MFX1),” “Send 2 (MFX2)” on page 12, 129, 154, “Trk (Track MIDI Out)” on page 62, 184.)
- When you adjust Send 1 (MFX1) or Send 2 (MFX2) in Sequencer mode, or when you re-select a song or return to the beginning of the measure in Sequencer mode, Send 1/2 will be transmitted by each track whose “Status” is BTH, EXT, or EX2.

Effect 2 depth (IFX1–5 on/off) (CC#92) [Bn, 5C, vv]

Effect 4 depth (MFX1, 2 on/off) (CC#94) [Bn, 5E, vv]

Effect 5 depth (TFX on/off) (CC#95) [Bn, 5F, vv]

Separately from the effect on/off settings in each mode, Effect SW (☞ p.59) allows you to turn off insert effects IFX1–5 and master effects MFX1, 2 and total effect TFX.

If you turn on IFX1–5 Off, MFX1&2 Off or TFX Off, the corresponding message will be transmitted with vv=0 [00]. If you turn off these settings, the corresponding message will be transmitted with vv=127 [7F]. If you turn on these set-

tings, the corresponding effect(s) will be turned off as a group. If you turn off these settings, the on/off settings of each mode will be used. The same applies to reception. (vv of 00 is off, and 01 or greater is the original setting.) These messages are transmitted/received on the global MIDI channel.

These messages are defined simply for use in adjusting the effect levels, and may not have the same function on another instrument connected to the microSTATION.

Using various controllers

Here we will explain typical ways to use the various controllers. You can choose from MIDI CC#00–CC#119 for knobs 1–4 when the Realtime Control B mode is selected.

Foot pedal (CC#04) [Bn, 04, vv]

If the CC# above is assigned as the Assignable Pedal function, this message will be transmitted when the controller is used.

- In Combination and Sequencer modes, transmission/reception of this message can be turned on/off independently for each timbre/track (“Enable Foot Pedal/Switch” [p.150](#), [p.169](#)).

Knob modulation 1–B, 2–B, 3–B, 4–B (CC#17, 19, 20, 21) [Bn, 11, vv], [Bn, 13, vv], [Bn, 14, vv], [Bn, 15, vv]

If the CC# above are assigned to the knobs 1–4 when the Realtime Control B mode is selected, these messages will be transmitted when the knobs are used.

- In Combination and Sequencer modes, transmission/reception of this message can be turned on/off independently for each timbre/track (“Enable Realtime Control Knob 1–B, 2–B, 3–B, 4–B” [p.22](#), [p.41](#), [p.151](#), [p.170](#)).

Controller (CC#18) [Bn, 12, vv]

Controller (CC#83) [Bn, 53, vv]

If you assign the CC# above to a knobs 1–4 when the Realtime Control B mode is selected, this message will be transmitted when you use the knobs 1–4.

Damper pedal (CC#64) [Bn, 40, vv]

This message is transmitted when you use a damper pedal (optional DS-1H) connected to the DAMPER/PEDAL/SW jack, and the damper effect will be turned on/off. If the DS-1H is used, a half-damper effect can be applied.

- In Combination and Sequencer modes, transmission/reception of this message can be turned on/off independently for each timbre/track (“Enable Damper” [p.22](#), [p.40](#), [p.150](#), [p.169](#)).

Foot switch (CC#82) [Bn, 52, vv]

If the CC# above is assigned as the function of the foot switch, using the switch will transmit this message with vv=127 [7F] for ON, and vv=00 [00] for OFF.

In Combination and Sequencer modes, transmission/reception of this message can be turned on/off independently for each timbre/track (“Enable Foot Switch” [p.23](#), [p.41](#), [p.150](#), [p.169](#)).

Sostenuto (CC#66) [Bn, 42, vv]

If the CC# above is assigned as the function of the foot switch, using the switch will transmit this message with vv=127 [7F] for ON, and vv=00 [00] for OFF, and the sostenuto effect will be turned on/off. When this message is received, the result will be the same as when the controller is used (OFF for vv=63 [3F] or below, and ON for vv=64 [40] or above).

Soft pedal (CC#67) [Bn, 43, vv]

If the CC# above is assigned as the function of the foot switch, using the switch will transmit, and the soft pedal effect will be turned on. When this message is received, the result will be the same as when the controller is used.

When “Foot pedal (CC#04)”–“Soft pedal (CC#67)” are used on the microSTATION, the specified alternate modulation or dynamic modulation etc. will be controlled. When these messages are received, the result will be the same as if the controller had been used. For “Foot switch (CC#82)”–“Soft pedal (CC#67),” vv of 63 [3F] or less will be OFF, and 64 [3F] or greater will be ON.

Controlling via the controllers of a connected MIDI instrument such as the M3

Ribbon Controller (CC#16) [Bn, 10, vv]

When a control change is received from the ribbon controller or other assigned controller of a MIDI instrument (such as the M3), the specified effect (e.g., alternate modulation or dynamic modulation) will be applied.

- In Combination or Sequencer modes, transmission and reception can be turned on/off for each timbre/track. (“Enable Ribbon CC#16” on page 104, page 161)

SW1 modulation (CC#80) [Bn, 50, vv]

SW2 modulation (CC#81) [Bn, 51, vv]

When the control change assigned for SW1 or SW2 of a MIDI device such as the M3 is received, the assigned alternate modulation or dynamic modulation effect will be applied.

In Combination or Sequencer mode, transmission/reception can be turned on/off for each timbre/track ([“Enable Other CC” p.150, p.169](#)).

Controller (CC#85, 86, 87, 88)

When the VALUE slider of MIDI instruments such as the M3, or a control change assigned to a controller is received, the specified alternate modulation or dynamic modulation effect will be applied.

Controlling Program tone & envelope shapes

CC#70–79 control specific parameters of a program.

For details on the program parameters that correspond to each control change, and how the microSTATION will respond in each mode when these are received, refer to “microSTATION and MIDI CCs” on page 299

Filter cutoff (CC#74) [Bn, 4A, vv]

Resonance level (CC#71) [Bn, 47, vv]

Filter EG intensity (CC#79) [Bn, 4F, vv]

Release time (CC#72) [Bn, 48, vv]

These messages are transmitted when you use the Realtime Control B mode knobs 1–4. (They can also be set as Realtime Control knob 1-B – 4-B functions.)

Sustain level (CC#70) [Bn, 46, vv]

Attack time (CC#73) [Bn, 49, vv]

Decay time (CC#75) [Bn, 4B, vv]

LFO 1 speed (CC#76) [Bn, 4C, vv]

LFO 1 depth (pitch) (CC#77) [Bn, 4D, vv]

LFO 1 delay (CC#78) [Bn, 4E, vv]

These messages are transmitted when assign the above CC# to the Realtime Control B mode knobs 1–4 function.

When you use these, the corresponding program parameters will be controlled, and the sound and envelope will change. When these messages are received, the result will be the same as when the controller is used. (When the message

has a value $vv=64$ [40], the setting will have the value that was set by the program parameter.)

- In Combination and Sequencer modes, transmission/reception can be turned on/off independently for each timbre/track (Enable Realtime Controls Knob 1-A-4-B [p.22](#), [p.41](#), [p.151](#), [p.170](#)).

Note: In Program mode, the corresponding program parameters will be temporarily edited by these messages. You can Write the program to save the modified state (except for certain parameters). The Write operation can also be performed by a MIDI System Exclusive Program Write Request message, in addition to the usual method of using the microSTATION's switches. When you write the data, the values of the corresponding program parameters will be rewritten.

Note: The results of receiving these messages will depend on the instrument. The operation may be different when a device other than the microSTATION is connected.

Control the arpeggiator

If you assign the following CC#s to knob and button of arpeggiator, the specified CC# will be transmitted when you operate the microSTATION, and the microSTATION itself will be controlled simultaneously. When these messages are received, the result will be the same as if you operated the microSTATION itself.

The CC# settings for the knobs and switches are made in the Global/Media: Controllers—ARP RTC CC#. However, you can edit these settings if you need to assign MIDI control change messages to the controllers, such as when you want to record the Realtime control C mode knobs, ARP ON/OFF button, and ARP LATCH button operations on the internal sequencer or an external MIDI sequencer, or to control the arpeggiator from an external MIDI device. If Global/Media: MIDI—ARP RTC MIDI, "MIDI Out" is set to CC, MIDI control change messages will be transmitted. ("MIDI Out" on page 63, 185)

Each knob and button can be assigned any MIDI control change CC#00–CC#119, or a desired MIDI note number. However, you will normally use the default settings that are assigned when you use the menu command Reset Controller MIDI Assign with CC Default.

For more information, please see "Reset ARP CC#" on page 66.

The operations described below are for these CC Default settings. Transmitted when the corresponding microSTATION controller is transmitted. When this is received, the same effect will apply as when the microSTATION's controller is operated.

ARP ON/OFF (CC#14) [Bn, 0E, vv]

Corresponds to the ARP ON/OFF button. It will transmit $vv=127$ [7F] when On, and $vv=127$ [7F] when Off.

ARP LATCH ON/OFF (CC#31) [Bn, 1F, vv]

Corresponds to the ARP LATCH button. It will transmit $vv=127$ [7F] when On, and $vv=127$ [7F] when Off.

KNOB1 – ARP GATE (CC#22) [Bn, 16, vv]

KNOB2 – ARP VELOCITY (CC#23) [Bn, 17, vv]

KNOB3 – ARP SWING (CC#24) [Bn, 18, vv]

Corresponds to knobs 1–3 when the Realtime controls is set to C mode.

Silencing all notes on a specific channel

All note off (CC#123) [Bn, 7B, 00] (value 00)

When this is received, all currently-sounding notes on that channel will be turned off (as though the keys had been released). However, the release portion of the notes will remain.

All sound off (CC#120) [Bn, 78, 00] (value 00)

When this is received, all currently-sounding notes on that channel will be silenced. While the All Note Off message allows the release portion of the notes to remain, the All Sound Off message will silence the notes immediately.

However, these messages are provided for emergency use, and are not something that you will use while performing.

Resetting all controllers on a specific channel

Reset all controllers (CC#121) [Bn, 79, 00] (value 00)

When this is received, the value of all controllers on that channel will be reset.

Using RPN (Registered Parameter Numbers)

RPN (Registered Parameter Numbers) are a type of message that allow settings to be made in a way that is common between instrument manufacturers. (NRPN (Non-registered Parameter Numbers) and exclusive messages can be freely used in non-compatible ways by different manufacturers and models of instrument.)

RPN messages can be used for editing with the following procedure.

1. Use RPN MSB (CC#101) [Bn, 65, mm] and RPN LSB (CC#100) [Bn, 64, rr] (n: channel, mm, rr: upper and lower bytes of the parameter number) messages to select the parameter.
2. Use data entry MSB (CC#6) [Bn, 06, mm] and data entry LSB (CC#38) [Bn, 26, vv] (n: channel, mm, vv: upper and lower bytes of the value, together expressing 16,384 levels) to specify the value.
3. You can use data increment (CC#96) [Bn, 60, 00] or data decrement (CC#97) [Bn, 61, 00] (n: channel, value is fixed at 00) to change the value in steps of one.

The microSTATION can receive the following three RPN messages (tuning, transpose, and pitch bend range).

Tuning

RPN fine tune [Bn, 65, 00, 64, 01]

This RPN message can be used to adjust the detuning for a program or timbre (in Combination mode), or for a track (in Sequencer mode).

The procedure is as follows.

[Bn, 65, 00, 64, 01]: Select RPN parameter 01.

[Bn, 06, mm, 26, vv]: Use data entry to set the value. A value of 8192 [mm, vv=40, 00] is center, 0 [mm, vv=00, 00] is -100 cents, and 16383 [mm, vv=7F, 7F] is +99 cents.

Note: You can use the universal exclusive Fine Tune message to adjust the overall tuning that corresponds to the Master Tune ([p.57](#), [p.182](#)) parameter. (See "About system exclusive messages" on page 308.)

Transposing

RPN coarse tune [Bn, 65, 00, 64, 02]

This RPN message can be used to adjust the transposition for a program or timbre (in Combination mode), or for a track (in Sequencer mode).

The procedure is as follows.

1. [Bn, 65, 00, 64, 02]: Select RPN parameter 02.
2. [Bn, 06, mm, 26, vv]: Use data entry to set the value. Normally only the upper byte is used.

A value of 8192 [mm, vv=40, 00] is center, 6656 [mm, vv=34, 00] is -12 semitones, and 9728 [mm, vv=4C, 00] is +12 semitones.

You can use the universal exclusive Coarse Tune message to adjust the overall tuning that corresponds to the Key Transpose (p.57, p.182) parameter. (See "About system exclusive messages" on page 308.)

Changing the pitch bend range

RPN pitch bend range [Bn, 64, 00, 65, 00]

This RPN message can be used to adjust the pitch bend range for a program or timbre (in Combination mode) or for a track (in Sequencer mode).

The procedure is as follows.

1. [Bn, 65, 00, 64, 00]: Select RPN parameter 00.
2. [Bn, 06, mm, 26, vv]: Use data entry to set the value. Normally only the upper byte is used.

A value of 0 [mm, vv=00, 00] is +00, and a value of 1536 [mm, vv=0C, 00] is +12 (one octave). Although it is possible to set a negative value for a timbre/track, only positive values can be set using RPN messages.

About system exclusive messages

In addition to the channel messages that handle performance data, MIDI provides a type of message called "system messages" which are used to send and receive data, control commands, and settings between MIDI devices.

Of these system messages, there is a subset called "system exclusive messages"; these are MIDI messages that can be freely used by each manufacturer. System exclusive messages provide the flexibility to transmit and receive data and settings that are specific to an individual manufacturer or model of device.

System exclusive messages that are specific to a manufacturer contain the following information:

- Manufacturer ID
- Model ID
- Device ID

These messages are used for communication between devices of the same model, or to communicate with dedicated computer editing software.

Since the way in which these messages are used is left up to each manufacturer, they are mainly used to transmit and receive sound data and editing data for parameters that are unique to a particular instrument. The microSTATION's system exclusive message format is [F0, 42, 3n, 00, 01, 0D, ff, F7]

F0: exclusive status

42: Korg ID

3n: [n=0-F] global MIDI channel 1-16

mm: Model ID byte 1 (00)

mm: Model ID bytes 2 (01)

mm: Model ID bytes 3 (0D)

ff: function ID (type of message)

:

:

F7: end of exclusive

To obtain a copy of the "MIDI Implementation" which includes MIDI System Exclusive format information, please contact your Korg distributor.

Universal system exclusive messages

Some system exclusive messages have a function that is agreed-upon by all manufacturers; these are called "universal system exclusive messages," and do not contain a manufacturer ID or model ID.

This means that they can simultaneously control all MIDI devices that have a matching device ID.

Of the universal system exclusive messages that are defined, the microSTATION supports the following six.

Inquiry message request [F0, 7E, nn, 06, 01, F7]

Inquiry message [F0, 7E, nn, 06, 02, (nine bytes), F7]

When an inquiry message request is received, the microSTATION will respond by transmitting an inquiry message that means "I am a Korg microSTATION, with system version ..."

GM system on [F0, 7E, nn, 09, 01, F7]

When this message is received in Sequencer mode, the microSTATION will be initialized for GM playback.

Master volume [F0, 7F, nn, 04, 01, vv, mm, F7]

(vv: lower byte of the value, mm: upper byte of the value, together indicating 16384 steps)

This message is transmitted if you assign Master Volume as the function of the foot pedal or as a Realtime Control B knobs 1-4. This will adjust the overall volume balance without changing the relative volume balance between timbres/tracks. When this message is received, the result will be the same as when the controller is used.

Master balance [F0, 7F, nn, 04, 02, vv, mm, F7]

(vv: lower byte of the value, mm: upper byte of the value, together indicating 16384 steps, where 8192 is the default position, and lower values will move the sound toward the left)

When this is received, the overall panning will be adjusted without changing the relative panning between timbres/tracks.

Master fine tuning [F0, 7F, nn, 04, 03, vv, mm, F7]

(A value of 8192 [mm, vv=40, 00] is center, 4096 [mm, vv=20, 00] is -50 cents, and 12288 [mm, vv=60, 00] is +50 cents.)

When this is received, the "MTune (Master Tune)" parameter will be set.

Master coarse tuning [F0, 7F, nn, 04, 04, vv, mm, F7]

(Normally only the upper byte mm is used. A value of 8192 [mm, vv=40, 00] is center, 6656 [mm, vv=34, 00] is -12 semitones, and 9728 [mm, vv=4C, 00] is +12 semitones.)

When this is received, the "Transpose" parameter will be set.

Transmitting sound settings data (Data Dump)

Data for programs, combinations, drum kits, user arpeggio pattern, global settings, and sequencer data can be transmitted as MIDI System Exclusive messages. The operation of sending this system exclusive data to an external device is called a “data dump.”

By performing a data dump, you can store the microSTATION’s sounds and settings on an external device, or rewrite the sounds and settings of another microSTATION.

If the “SysEx (EnableExclusive)” (☞p.63) setting is on, data will also be dumped in response to a Dump Request message. This data is transmitted and received on the global MIDI channel.

When the microSTATION receives this data, the data will be written into the edit buffer. If you want to save the data into internal memory, you’ll have to save by using the Write operation. This can be done either by executing the Write operation (See “Writing to internal memory” on page 58 of the Operation Guide) on the microSTATION itself, or by a MIDI System Exclusive program write request, combination write request, drum kit write request, user arpeggio pattern write request or global setting write request.

Editing sounds via SysEx

By using various MIDI System Exclusive data dumps, you can rewrite all programs or an individual program. By using parameter change messages, you can edit individual parameters as follows.

Parameter changes

- In Program mode, all parameters other than the program name can be edited.
- In Combination mode, parameters other than the combination name can be edited.
- In Sequencer mode, you can edit the track parameters, arpeggiator, insert effects, master effects, and total effects parameters. (See “System Exclusive events supported in Sequencer mode” on page 55.)

Drum kit parameter change, User arpeggio pattern parameter change

In microSTATION Editor’s Global mode, you can edit drum kits and user arpeggio patterns. The global MIDI channel is used to transmit and receive this data. First turn “Sys Ex” (☞p.63) On so that exclusive data can be transmitted and received. When you switch modes on the microSTATION, a mode change is transmitted. When you edit a parameter, a parameter change will be transmitted.

When these messages are received, the same editing operation will be performed as on the transmitted device.

Cautions regarding data dumps and sound editing

- After MIDI System Exclusive data has been received and processed, a Data Load Completed message will be transmitted. The control master device must not transmit the next message until this message is received (or until a sufficient interval of time has elapsed).
- When you change use parameter changes to edit, the changes will affect the data in the edit buffer and will not be stored in internal memory unless you Write, so that the changes will be lost if you re-select the program or combination. The Write operation can be performed by a MIDI System Exclusive Program Write Request or Combination Write Request message, in addition to the usual method of using the microSTATION’s switches.

For more information, please see “Writing to internal memory” on page 58 of the Operation Guide.

- There is no need to write a song, but it will not be backed-up when you turn off the power. Important data that you want to keep must be saved to an SD card before you turn off the power. For more information, please see “Saving to media” on page 60 of the Operation Guide.

If notes are stuck

If a problem has caused notes to continue sounding even though you’ve stopped playing the keyboard (or stopped playing via MIDI), you can stop the stuck notes by switching modes on the microSTATION.

Playing the microSTATION multi-timbrally from an external device

The microSTATION can be connected to an external device and played multi-timbrally in the following ways.

MIDI messages from the external device can play a combination (16-part multi-timbral performance). You can change the overall settings (programs, levels, and effects) by using program change messages to switch combinations.

MIDI messages from the external device can be used to play a song (16-part multi-timbral performance). Overall settings (programs, levels, effects etc.) can be changed by using a Song Select message to switch songs.

MIDI Clock messages from the external device can be used to make the microSTATION playback a song (set “Clock (MIDI Clock)” to Ext.MIDI, and run the microSTATION’s sequencer). (☞“Synchronizing the playback of the Arpeggiator or sequencer”) You can change the overall settings (programs, levels, effects) by using song select messages to switch songs.

“Clock” Ext.USB will operate in the same way as Ext.MIDI. With the Auto setting, an external MIDI clock received at the MIDI IN connector or the USB B connector will automatically cause the microSTATION to switch to the same method of operation as Ext.MIDI or Ext.USB.

Synchronizing the playback of the Arpeggiator or sequencer

The choice of whether the microSTATION will be the master (the controlling device) or the slave (the controlled device) is made by “Clock (MIDI Clock)” (☞p.62).

When “Clock” is set to Auto, the microSTATION will normally operate in the same way as for the Internal setting. When an external MIDI clock is received from the MIDI IN or USB connector, the microSTATION will automatically operate as for the External MIDI setting.

Using the microSTATION as master and the external MIDI device as slave

- Connect the microSTATION’s MIDI OUT connector to the MIDI IN connector of the external MIDI device. Connect the microSTATION’s USB B connector to your computer’s USB port. When you set “Clock” to Internal, the microSTATION will be the master device, and will transmit MIDI timing clock messages. Arpeggiator: The tempo can be controlled from the microSTATION. Performance data will be transmitted via MIDI. (Perfor-

mance data from the Arpeggiator in Combination or Sequencer mode will be transmitted from timbres or MIDI tracks whose "Status" is BTH, EXT, or EX2.) An external tone generator connected to MIDI OUT or USB will sound, and the tempo of an external sequencer can be controlled.

Sequencer: The musical data can be played back and controlled on the microSTATION.

Simultaneously, the sequencer playback will be transmitted via MIDI from MIDI tracks whose "Status" is BTH, EXT, or EX2. An external tone generator connected to MIDI OUT or USB will sound, and the tempo of an external sequencer can be controlled.

Using the external MIDI device as master and the microSTATION as slave

Connect the microSTATION's MIDI IN connector to the MIDI OUT connector of the external MIDI device. Connect the microSTATION's USB connector to your computer's USB port.

- If you use the MIDI connectors to make connections, set "Clock" to External MIDI. If you use the USB connector to make connections, set it to External USB. The microSTATION will be the slave.

Arpeggiator: The tempo will follow the MIDI timing clock. If you playback the external sequencer, the microSTATION's Arpeggiator will synchronize to the external timing clock.

Even if "Clock" is Ext.MIDI or Ext.USB and the microSTATION is being controlled from the external device, the performance of the Arpeggiator will still be transmitted via MIDI. (Performance data from the arpeggiator in Combination or Sequencer mode will be transmitted from timbres or MIDI tracks whose "Status" is BTH, EXT, or EX2.)

Sequencer: The microSTATION will not be able to control the performance data; it will be controlled by the external MIDI device connected to MIDI IN or the computer connected to USB. If you wish to playback the external sequencer to make the microSTATION's sequencer playback in synchronization to the external timing clock, you must first set the same time signature and starting measure locations on both devices.

Even if "Clock" is set to Ext.MIDI or Ext.USB and the microSTATION is being controlled from an external device, musical data will be transmitted by tracks whose "Status" is BTH, EXT, or EX2.

Recording musical data from an external device

There are two ways in which you can play back an external sequencer and record its playback on the microSTATION.

- Set "Clock (MIDI Clock)" (p.62) to Internal, begin recording, and then start the external sequencer. With this method, the MIDI messages will be recorded without the two devices being synchronized. Since the incoming musical data will simply be recorded, this method allows the performance to be reproduced faithfully, but since measure divisions etc. will not be kept track of, this method is not suitable if you intend to edit the data later.
- If you set "Clock" to Ext.MIDI or Ext.USB, the start of recording and the tempo etc. will all be under the control of the external sequencer. Since the two devices will be synchronized during the recording process, measure divisions etc. will be

accurately preserved. (You will need to set the time signature before recording.)

Recording MIDI data from an external sequencer etc. to multiple MIDI tracks simultaneously

1. Make sure that your external sequencer's MIDI OUT is connected to the microSTATION's MIDI IN via a MIDI cable.
If it's not connected, turn off the power, make the connection, and then turn the power on again.
2. In Global/Media mode, set the MIDI - MIDI Clock, "Clock" setting to External MIDI. Now the microSTATION will synchronize to the MIDI clock of your external sequencer.
Make sure that "Rcv ExtRTC" is On.
3. In Sequencer mode, create a new song.
4. In SEQ: Edit - Tracks, Track 01–Track 16, use "MIDI Ch." to specify the MIDI channel of each track. Set the MIDI channels of the microSTATION's tracks to match the MIDI channels of each track on your external sequencer. Data of the same channel will be recorded to the microSTATION's corresponding track.
Make sure that "Status" is set to INT or BTH.
5. Use "Set Location" to set the location to 001:01.
6. Press the REC button to enter record-standby mode.
7. Set "M (Recording Mode)" to OVW (Overwrite), and use the 01–16 buttons to select the tracks that you want to record.
8. Start your external sequencer.
When the MIDI start message transmitted by your external sequencer is received, the microSTATION will automatically start recording.
9. When recording is finished, stop your external sequencer. The microSTATION's sequencer will receive the MIDI stop message transmitted by your external sequencer, and will stop recording automatically. You can also stop recording by pressing the microSTATION's START/STOP button.
10. Play back.
11. In Global/Media mode, MIDI - MIDI Clock, set "Clock" to Internal.
SEQ: Set the Song - Song "Tempo Mode" to Auto.
Press the START/STOP button to play back.

Recording the MIDI output of the microSTATION's controllers, Arpeggiator and internal sequencer to an external sequencer/computer

If you wish to record the MIDI output of the microSTATION's controllers, Arpeggiator, and internal sequencer on an external sequencer or computer and use the microSTATION as the monitoring and playback tone generator while you record, you must turn off the microSTATION's Local Control setting ("Local Ctrl" p.61), and set your external sequencer/computer for echo-back (a function by which the data received at MIDI IN is retransmitted without change from MIDI OUT) so that the data from the microSTATION's controllers, Arpeggiator, and internal sequencer will not be applied in duplicate to the tone generator.

Using the Realtime Control Knob 1–4 to record MIDI control changes on an external MIDI sequencer/computer

- Set the microSTATION to Local Control Off.
- Set the external MIDI sequencer/computer to Echo Back On.

With these settings, recording and playback will occur correctly, and the control changes will not be applied to the tone generator in duplicate.

Recording the Arpeggiator on an external MIDI sequencer/computer

When the arpeggiator is on, playing the keyboard or operating the controllers of the microSTATION will operate and control the arpeggiator.

In the same way, the arpeggiator will be controlled by MIDI messages received from MIDI IN.

Notes transmitted from MIDI OUT (USB) by the arpeggiator are controlled as follows, according to the local control setting (“Local Ctrl” [p.61](#)).

Local Control On: Notes from the arpeggiator will be transmitted from MIDI OUT (USB).

Local Control Off: Notes from the arpeggiator will not be transmitted from MIDI OUT (USB). The microSTATION will sound only in response to MIDI messages received at MIDI IN, or generated by the arpeggiator.

Setting example 1

Record the note messages generated by the arpeggiator on the external MIDI sequencer/computer.

1. Turn on this instrument’s arpeggiator. Set this instrument to Local Control On.
2. Turn Local Control On for this instrument.
Turn Echo Back Off on your external sequencer/computer.
By turning echo back off, you will prevent the arpeggiator from performing duplicate processing on the monitored notes during recording.
3. During playback, turn off the arpeggiator of microSTATION.

Setting example 2

Use the external MIDI sequencer/computer to record only the notes that trigger the arpeggiator, and operate this instrument’s arpeggiator for monitoring while recording, and during playback.

1. Turn on the microSTATION’s arpeggiator.
2. Set the microSTATION to Local Control Off.
The note messages generated by the arpeggiator will not be output.
3. On your external MIDI sequencer/computer, turn echo back on.
With these settings, the data will be recorded and played correctly, and the arpeggiator will not be applied in duplicate.

About GM (General MIDI)

The microSTATION supports the GM standard. It also supports the GM2 sound map (including bank select) with 256 programs and 9 drum programs provided in ROM banks GM, g(1)–g(9), and g(d). (Banks g(1)–g(9) are GM2 variation programs, and g(d) contains drum programs.)

GM is a standard that ensures basic compatibility of sounds and controllers between GM-compatible instruments made by different manufacturers. When using GM with microSTATION, be aware of the following.

- GM System On is supported in Sequencer mode. For more information, please see “GM Initialize” on page 49.
- When you wish to play a GM sequence, or load GM data into a song, set Bank Map ([p.59](#)) to GM(2).

About standard MIDI files

Standard MIDI files (SMF) make it possible for different computer programs or musical instruments made by different manufacturers to exchange time-based MIDI data. Each standard MIDI file contains one song. The microSTATION supports format 0 (type 0) in which all of the MIDI data is combined into one track, and format 1 (type 1) in which the data is separated by track.

When a SMF is loaded into a song in Global/Media mode, the program bank that is selected will differ depending on the Bank Map ([p.59](#)) setting. When playing/loading SMF data that conforms to the GM specifications, set “Bank Map” to GM(2).

Sequencer mode

In Global/Media mode when you convert a song into a Standard MIDI File and save it, you can choose either format 0 or format 1.

- If microSTATION song data that was saved as a format 1 SMF file is loaded into another device, the track configuration may be different than it was before being saved. This is because MIDI tracks that contain no musical data are omitted, and the remaining tracks are moved into the unused tracks. This will not affect the playback itself.
- If song data that was saved by another device as a format 1 SMF file is loaded into the microSTATION, the track configuration may be different than it was before being saved. This is because tracks that contain no musical data are omitted, and the remaining tracks are moved into the unused tracks. This will not affect the playback itself.

When exchanging sequence data between two microSTATION, we recommend that you save the sequence data in the microSTATION’s native format (“Save SEQ”).

When sequence data is saved in the microSTATION’s native format, all of the settings and patterns unique to the microSTATION will be saved, which will ensure a higher level of reproducibility than when the data is saved as a Standard MIDI File (“Save to Std MIDI File”).

Parameter changes and other recorded data is included in the song data as System Exclusive events, so it can be saved to or loaded from media as usual. Exclusive messages can also be loaded or saved as SMF (Standard MIDI File) data (“Load Standard MIDI File,” “Save Song as Standard MIDI File”). This allows recorded System Exclusive events to be saved as SMF data, or exclusive messages included in SMF data to be converted into song data.

During playback, this data can be transmitted to an external MIDI device, or used to control track parameters or effect parameters of the song.

Shortcuts

REC button

- Begins the Auto Song Setup function.
In Program or Combination mode, pressing this button will automatically assign the program or combination settings to a Sequencer mode song, and put the microSTATION in record-ready mode.

KEY button + keyboard

- Enters a note number value or velocity value.
- In Sequencer mode while using loop recording or grid sequence, you can hold down the KEY button and press a note to delete the data for that note number.

WRITE button

- Writes a program or combination. When you press the WRITE button it will blink, and when you press the button once again the data will be written. To cancel without writing, press the ◀ button while the WRITE button is blinking.

WRITE button + LOCATE button

- In Sequencer mode, this specifies the location where you'll move when the LOCATE button is pressed.

Power-on while holding down the PLAY/MUTE button + function 08 button

- This will initialize the microSTATION.
The display will indicate "Initializing..." while the data is being loaded.
After initialization is completed, you'll need to load the preload data. Use Global/Media mode to load the data from an SD card that contains the preload data.

View bank and program numbers

- In a page where you can select a program, press the front panel NUM LOCK button to turn Num Lock on, and then press the ENTER (14) button.
Indications such as "A000" that are shown as the writing-destination or copy-destination for Write Program, Write Combination, or various copy commands will correspond to this bank and program number. As desired, you can switch this between displayed and hidden.
MIDI Implementation

microSTATION MIDI IMPLEMENTATION

8, Dec, 2009

Consult your local Korg dealer for more information on MIDI System Exclusive implementation.

1. TRANSMITTED DATA

1-1 CHANNEL MESSAGES

[H] :Hex, [D] :Decimal

Status	Second	Third		Description	(Transmitted by)	ENA
[Hex]	[H][D]	[H][D]				
8n	kk (kk)	40 (64)		Note Off	(Key Off)	*1 A
9n	kk (kk)	vv (vv)		Note On (vv)=1-127	(Key On)	*1 A
An	kk (kk)	vv (vv)		Poly Key Pressure	(Sequence data)	T,Q
Bn	00 (00)	mm (mm)		Bank Select(MSB)	(Prog/Combi change)	*2 PB
Bn	01 (01)	vv (vv)		Modulation1	(Joystick +Y, ASW/Pdl)	C
Bn	02 (02)	vv (vv)		Modulation2	(Joystick -Y, ASW/Pdl)	C
Bn	04 (04)	vv (vv)		Foot Pedal	(Pdl = Foot Pedal)	C
Bn	05 (05)	vv (vv)		Portamento Time	(Knob/Pdl = Porta.Time, S Chg)	C
Bn	07 (07)	vv (vv)		Volume	(Knob/Pdl = Volume, S/C Chg)	C
Bn	08 (08)	vv (vv)		Post IFX Panpot	(Knob/Pdl = Post IFX Pan, S Chg)	C
Bn	0A (10)	vv (vv)		Panpot	(Knob/Pdl = Pan, S Chg)	C
Bn	0B (11)	vv (vv)		Expression	(Knob/Pdl = Expression)	C
Bn	0C (12)	vv (vv)		Effect Control 1	(Knob/Pdl = FX Control1)	C
Bn	0D (13)	vv (vv)		Effect Control 2	(Knob/Pdl = FX Control2)	C
Bn	0E (14)	00/7F (00/127)			(ARP ON/OFF, ASW)	*3 C
Bn	10 (16)	vv (vv)		Multi Purpose Ctrl1	(ASW/Pdl = CC#16(Rbn))	C
Bn	11 (17)	vv (vv)		Multi Purpose Ctrl2	(Knob = Knob Mod1)	C
Bn	13 (19)	vv (vv)		Multi Purpose Ctrl4	(Knob = Knob Mod2)	C
Bn	14 (20)	vv (vv)			(Knob = Knob Mod3)	C
Bn	15 (21)	vv (vv)			(Knob = Knob Mod4)	C
Bn	16 (22)	vv (vv)			(ARP Knob1 GATE, ASW/Pdl)	*3 C
Bn	17 (23)	vv (vv)			(ARP Knob2 VELOCITY, ASW/Pdl)	*3 C
Bn	18 (24)	vv (vv)			(ARP Knob3 SWING, ASW/Pdl)	*3 C
Bn	1F (31)	00/7F (00/127)			(ARP LATCH, ASW)	*3 C
Bn	20 (32)	bb (bb)		Bank Select(LSB)	(Prog/Combi change)	*2 PB
Bn	40 (64)	vv (vv)		Hold1	(Damper, ASW)	C
Bn	41 (65)	00/7F (00/127)		Portamento Off/On	(ASW = Porta.SW, S Chg)	C
Bn	42 (66)	00/7F (00/127)		Sostenuto Off/On	(ASW = Sostenuto)	C
Bn	43 (67)	00/7F (00/127)		Soft Pedal	(ASW = Soft)	C
Bn	46 (70)	vv (vv)		Sound Controller 1	(Knob = F/A Sustain)	C
Bn	47 (71)	vv (vv)		Sound Controller 2	(Knob2A, Knob = Resonance, ASW/Pdl)	C
Bn	48 (72)	vv (vv)		Sound Controller 3	(Knob4A, Knob = F/A Release, ASW/Pdl)	C
Bn	49 (73)	vv (vv)		Sound Controller 4	(Knob = F/A Attack)	C
Bn	4A (74)	vv (vv)		Sound Controller 5	(Knob1A, Knob = Filter Cutoff, ASW/Pdl)	C
Bn	4B (75)	vv (vv)		Sound Controller 6	(Knob = F/A Decay)	C
Bn	4C (76)	vv (vv)		Sound Controller 7	(Knob = Pitch LFO1 Spd)	C
Bn	4D (77)	vv (vv)		Sound Controller 8	(Knob = Pitch LFO1 Dep)	C
Bn	4E (78)	vv (vv)		Sound Controller 9	(Knob = Pitch LFO1 Dly)	C
Bn	4F (79)	vv (vv)		Sound Controller 10	(Knob3A, Knob = Filter EG Int, ASW/Pdl)	C
Bn	50 (80)	vv (vv)		Multi Purpose Ctrl5	(Knob = SW1 Mod.)	C
Bn	51 (81)	vv (vv)		Multi Purpose Ctrl6	(Knob = SW2 Mod.)	C
Bn	52 (82)	vv (vv)		Multi Purpose Ctrl7	(ASW/Knob = Foot SW)	C
Bn	53 (83)	vv (vv)		Multi Purpose Ctrl8	(Knob = MIDI CC#83)	C

Appendices

Bn 5B (91) vv (vv)	Effect 1 Depth	(Knob/Pdl = MFX Send2, S Chg)	C
Bg 5C (92) 00/7F (00/127)	Effect 2 Depth	(All Insert FX Off/On)	C
Bn 5D (93) vv (vv)	Effect 3 Depth	(Knob/Pdl = MFX Send1, S Chg)	C
Bg 5E (94) 00/7F (00/127)	Effect 4 Depth	(Master FX1/2 Off/On)	C
Bg 5F (95) 00/7F (00/127)	Effect 5 Depth	(Total FX Off/On)	C
Bn cc (cc) vv (vv)	Control (cc)=0-119	(Sequencer data)	Q
Bn cc (cc) vv (vv)	Control (cc)=0-119	(Knob = MIDI CC#00-119)	C
Bn cc (cc) vv (vv)	Control (cc)=0-119	(ARP Controllers = MIDI CC#00-119)	C
Bn cc (cc) vv (vv)	Control (cc)=0-119	(External Mode = MIDI CC#00-119)	A
Cn pp (pp) -- --	Program Change	(Prog/Combi change)	*2 P
Dn vv (vv) -- --	Channel Pressure	(Sequence data)	T,Q
En bb (bb) bb (bb)	Bender Change	(Joy Stick X)	C

Pdl : Assignable Pedal

ASW : Assignable Switch

Knob : Realtime Knob1B,2B,3B,4B

S Chg : Transmitted when change a Song No.(Seq. mode). (Status = EXT,EX2,BTH)

C/S Chg : Transmitted when change a Combination or Song No.(Seq. mode). (Status = EXT,EX2 or BTH)

n : MIDI Channel No. (0 - 15) Usually Global Channel.

When in Combination/Sequencer mode, each timbre's/track's channel. (Status = EXT,EX2 or BTH)

g : Always Global Channel No. (0 - 15)

ENA = A : Always Enabled.

C : Enabled when Enable Control Change in Global mode is on.

P : Enabled when Enable Program Change in Global mode is on.

PB: Enabled when Enable Program and Bank Change in Global mode is on.

T : Enabled when Enable After Touch in Global mode is on.

Q : Enabled when Sequencer is playing(transmit), recording(receive)

*1 : kk = 24 - 108 : 61keys + Transpose

= 00 - 127 : Sequencer and ARP

*2 : Program	Combination	MIDI Out[Hex]	(Bank Map is KOR)	(Bank Map is GM(2))
Bank A 000 - 127 : Bank	A 000 - 127 : mm,bb,pp	= 00,00,	00 - 7F	= 3F,00, 00 - 7F
B 000 - 127 :	B 000 - 127 :	00,01,	00 - 7F	3F,01, 00 - 7F
C 000 - 127 :	C 000 - 127 :	00,02,	00 - 7F	3F,02, 00 - 7F
D 000 - 127 :		00,03,	00 - 7F	3F,03, 00 - 7F
GM 001 - 128 :		79,00,	00 - 7F	79,00, 00 - 7F
g 001 - 128 :		79,01-09,	00 - 7F	79,01-09, 00 - 7F
g(d) 001 - 128 :		78,00,	00 - 7F	78,00, 00 - 7F

*3 : When CC# by "CC Default" is assigned to the ARP Controllers in Global Mode.

Reset ARP CC# = CC Default

ARP ON/OFF :CC#14

ARP LATCH :CC#31

ARP Knob1 GATE :CC#22

ARP Knob2 VELOCITY :CC#23

ARP Knob3 SWING :CC#24

1-2 SYSTEM COMMON MESSAGES

[H] :Hex, [D] :Decimal

Status	Second	Third	Description (Transmitted when)	
[Hex]	[H]	[D]	[H]	[D]
F2	ss (ss)	tt (tt)	Song Position Pointer ss : Least significant [LSB] *4 tt : Most significant [MSB] *4	
F3	ss (ss)		Song Select ss : Song(0-127)	

Transmits Song Position Pointer message when in Sequencer mode. (Internal Clock)
 Transmits Song Select message when in Sequencer mode.

*4 : For example, if time signature is 4/4 or 8/8, tt,ss = 00,10 means one measure.

1-3 SYSTEM REALTIME MESSAGES

Status[Hex]	Description	(Transmitted when ...)	
F8	Timing Clock	(Always in Prog/Combi/Seq mode)	*5
FA	Start	(START in Seq mode)	*5
FB	Continue	(Continue START in Seq mode)	*5
FC	Stop	(STOP in Seq mode)	*5
FE	Active Sensing	(Always)	*6

*5 Transmits these messages when MIDI Clock in Global mode is Internal.

*6 Transmits these messages when MIDI Clock in Global mode is External.

1-4 SYSTEM EXCLUSIVE

1-4-1 UNIVERSAL SYSTEM EXCLUSIVE MESSAGE (NON REALTIME)

DEVICE INQUIRY REPLY (Transmits when received a INQUIRY MESSAGE REQUEST)

[F0,7E,0g,06,02,42,0D,01,05,00,vv,ww,xx,00,F7] 3rd byte g : Global Channel
 6th byte 42 : KORG ID
 7th byte 0D : microSTATION series ID
 8th byte 01 : microSTATION series ID
 9th byte 05 : microSTATION member code
 11th byte vv : System Version 1st (1 -)
 12th byte ww : System Version 2nd (0 -)
 13th byte xx : System Version 3rd (0 -)
 (i.e. Version 1.0.2: vv=01, ww=00, xx=02)

1-4-2 UNIVERSAL SYSTEM EXCLUSIVE MESSAGES (REALTIME)

Master Volume

[F0,7F,0g,04,01,vv,mm,F7] 3rd byte g : Global Channel
 6th byte vv : Value(LSB)
 7th byte mm : Value(MSB)
 mm,vv = 00,00 - 7F,7F : Min - Max

Appendices

2. RECOGNIZED RECEIVE DATA

2-1 CHANNEL MESSAGES

[H] :Hex, [D] :Decimal

[Hex]	[H]	[D]	[H]	[D]			
Status	Second	Third	Description (Use)			ENA	
[Hex]	[H]	[D]	[H]	[D]			
8n	kk	(kk)	xx	(xx)	Note Off	A	
9n	kk	(kk)	00	(00)	Note Off	A	
9n	kk	(kk)	vv	(vv)	Note On (vv) = 1-127	A	
An	kk	(kk)	vv	(vv)	Poly Key Pressure (as AMS)	T,Q	
Bn	00	(00)	mm	(mm)	Bank Select(MSB) (for Prog/Combi change)	*1 P	
Bn	01	(01)	vv	(vv)	Modulation1 (as Joy Stick +Y)	C	
Bn	02	(02)	vv	(vv)	Modulation2 (as Joy Stick -Y)	C	
Bn	04	(04)	vv	(vv)	Foot Pedal (as AMS & FX Dmod Src = Foot Pedal)	C	
Bn	05	(05)	vv	(vv)	Portamento Time	C	
Bn	06	(06)	vv	(vv)	Data Entry (MSB) (for RPC edit)	C	
Bn	07	(07)	vv	(vv)	Volume	C	
Bn	08	(08)	vv	(vv)	Balance Control (for Post IFX Panpot control)	*2 C	
Bn	0A	(10)	vv	(vv)	Panpot	C	
Bn	0B	(11)	vv	(vv)	Expression	C	
Bn	0C	(12)	vv	(vv)	Effect Control 1 (as FX Dmod Src = Fx Controll)	C	
Bn	0D	(13)	vv	(vv)	Effect Control 2 (as FX Dmod Src = Fx Control2)	C	
Bn	0E	(14)	vv	(vv)	(as ARP ON/OFF)	*4 C	
Bn	10	(16)	vv	(vv)	Multi Purpose Ctrl1 (as AMS & FX Dmod Src = CC#16(Rbn))	C	
Bn	11	(17)	vv	(vv)	Multi Purpose Ctrl2 (as AMS & FX Dmod Src = Knob Mod1)	C	
Bn	12	(18)	vv	(vv)	Multi Purpose Ctrl3 (as AMS & FX Dmod Src = CC#18(Val))	C	
Bn	13	(19)	vv	(vv)	Multi Purpose Ctrl4 (as AMS & FX Dmod Src = Knob Mod2)	C	
Bn	14	(20)	vv	(vv)	(as AMS & FX Dmod Src = Knob Mod3)	C	
Bn	15	(21)	vv	(vv)	(as AMS & FX Dmod Src = Knob Mod4)	C	
Bn	16	(22)	vv	(vv)	(as ARP Knob1 GATE)	*4 C	
Bn	17	(23)	vv	(vv)	(as ARP Knob2 VELOCITY)	*4 C	
Bn	18	(24)	vv	(vv)	(as ARP Knob3 SWING)	*4 C	
Bn	1F	(31)	vv	(vv)	(as ARP LATCH)	*4 C	
Bn	20	(32)	bb	(bb)	Bank Select(LSB) (for Prog / Combi change)	*1 P	
Bn	26	(38)	vv	(vv)	Data Entry (LSB) (for RPC edit)	C	
Bn	40	(64)	vv	(vv)	Hold1 (as Damper)	C	
Bn	41	(65)	≤ ^{3F} /≥ ⁴⁰	(≤ ⁶³ /≥ ⁶⁴)	Portamento Off/On	C	
Bn	42	(66)	≤ ^{3F} /≥ ⁴⁰	(≤ ⁶³ /≥ ⁶⁴)	Sostenuto Off/On	C	
Bn	43	(67)	vv	(vv)	Soft Pedal	C	
Bn	46	(70)	vv	(vv)	Sound Controller 1 (for Sustain Level control)	C	
Bn	47	(71)	vv	(vv)	Sound Controller 2 (for Resonance control)	C	
Bn	48	(72)	vv	(vv)	Sound Controller 3 (for Release Time control)	C	
Bn	49	(73)	vv	(vv)	Sound Controller 4 (for Attack Time control)	C	
Bn	4A	(74)	vv	(vv)	Sound Controller 5 (for Filter Cutoff control)	C	
Bn	4B	(75)	vv	(vv)	Sound Controller 6 (for Decay Time control)	C	
Bn	4C	(76)	vv	(vv)	Sound Controller 7 (for LF01 Speed control)	C	
Bn	4D	(77)	vv	(vv)	Sound Controller 8 (for LF01 Pitch Depth control)	C	
Bn	4E	(78)	vv	(vv)	Sound Controller 9 (for LF01 Delay control)	C	
Bn	4F	(79)	vv	(vv)	Sound Controller 10 (for Filter EG Intensity control)	C	
Bn	50	(80)	vv	(vv)	Multi Purpose Ctrl5 (as AMS & FX Dmod Src = CC#80)	C	
Bn	51	(81)	vv	(vv)	Multi Purpose Ctrl6 (as AMS & FX Dmod Src = CC#81)	C	

Bn 52 (82) vv	(vv)	Multi Purpose Ctrl7 (as AMS & FX Dmod Src = Foot Switch)	C
Bn 53 (83) vv	(vv)	Multi Purpose Ctrl8 (as AMS & FX Dmod Src = CC#83)	C
Bn 55 (85) vv	(vv)	(as AMS & FX Dmod Src = CC#85)	C
Bn 56 (86) vv	(vv)	(as AMS & FX Dmod Src = CC#86)	C
Bn 57 (87) vv	(vv)	(as AMS & FX Dmod Src = CC#87)	C
Bn 58 (88) vv	(vv)	(as AMS & FX Dmod Src = CC#88)	C
Bn 5B (91) vv	(vv)	Effect 1 Depth (for Send 2 Level control)	C
Bg 5C (92) 00/ ≠00	(00/≠000)	Effect 2 Depth (for All Insert FX Off/On)	C
Bn 5D (93) vv	(vv)	Effect 3 Depth (for Send 1 Level control)	C
Bg 5E (94) 00/ ≠00	(00/≠000)	Effect 4 Depth (for Master FX1,2 Off/On)	C
Bg 5F (95) 00/ ≠00	(00/≠000)	Effect 5 Depth (for Total FX Off/On)	C
Bn 60 (96) 00	(00)	Data Increment (for RPC edit)	C
Bn 61 (97) 00	(00)	Data Decrement (for RPC edit)	C
Bn 64(100) 0r	(0r)	RPN Param No. (LSB) (for RPN select)	*3 C
Bn 65(101) 00	(00)	RPN Param No. (MSB) (for RPN select)	*3 C
Bn cc (cc) vv	(vv)	Control data (for Seq. recording (cc) = 0-119)	C,Q
Bn 78(120) 00	(00)	All Sound Off	C
Bn 79(121) 00	(00)	Reset All Controllers	C
Bn 7A(122) 00/7F	(00/127)	Local Control Off/On	A
Bn 7B(123) 00	(00)	All Notes Off	A
Bn 7C(124) 00	(00)	Omni Mode Off (as All Notes Off)	A
Bn 7D(125) 00	(00)	Omni Mode On (as All Notes Off)	A
Bn 7E(126) 10 ≤	(≤16)	Mono Mode On (as All Notes Off)	A
Bn 7F(127) 00	(00)	Poly mode On (as All Notes Off)	A
Cn pp (pp) --	--	Program Change (for Prog/Combi change)	*1 P
Dn vv (vv) --	--	Channel Pressure (as AMS & FX Dmod Src = After Touch)	T
En bb (bb) bb	(bb)	Bender Change	C

AMS : Alternate Modulation Source
 FX Dmod Src : Effect Dynamic Modulation Source

n : MIDI Channel No. (0 - 15) Usually Global Channel.
 When in Combination/Sequencer mode, each timbre's/track's channel.(Status is INT or BTH)
 g : Always Global Channel No. (0 - 15)
 x : Random
 ENA : Same as Transmitted data

*1 : When Bank Map in Global mode is KORG;

MIDI In	[Hex]	Program	Combination
mm,bb,pp = 00,00,	00 - 7F	: Bank INT-A 000 - 127	: Bank INT-A 000 - 127
00,01,	00 - 7F	: INT-B 000 - 127	: INT-B 000 - 127
00,02,	00 - 7F	: INT-C 000 - 127	: INT-C 000 - 127
00,03,	00 - 7F	: INT-D 000 - 127	:
79,00,	00 - 7F	: G 001 - 128	
79,01-09,	00 - 7F	: g(1)-g(9) 001 - 128	
78,00,	00 - 7F	: g(d) 001 - 128	
38,00,	00 - 7F	: G 001 - 128	
3E,00,	00 - 7F	: g(d) 001 - 128	

When Bank Map in Global mode is GM(2);

Appendices

MIDI In [Hex]	Program	Combination
mm,bb,pp = 3F,00, 00 - 7F	: Bank INT-A 000 - 127	: Bank INT-A 000 - 127
3F,01, 00 - 7F	: INT-B 000 - 127	: INT-B 000 - 127
3F,02, 00 - 7F	: INT-C 000 - 127	: INT-C 000 - 127
3F,03, 00 - 7F	: INT-D 000 - 127	:
79,00, 00 - 7F	: G 001 - 128	
79,01-09, 00 - 7F	: g(1)-g(9) 001 - 128	
78,00, 00 - 7F	: g(d) 001 - 128	
00,00, 00 - 7F	: G 001 - 128	
38,00, 00 - 7F	: G 001 - 128	
3E,00, 00 - 7F	: g(d) 001 - 128	
3F,7F, 00 - 7F	: Mute (KORG MUTE)	

*2 : When in Program, Global channel.

When in Combination/Sequencer mode, each IFX's channel.

*3 : r = 0 : Pitch Bend Sensitivity (Bend Range)

= 1 : Fine Tune (Detune)

= 2 : Coarse Tune (Transpose)

For drum program, both of Fine Tune and Coarse Tune affect to Detune.

Data Entry LSB value has no effect for Pitch Bend Sensitivity and Coarse Tune.

*4 : When CC# by "CC Default" is assigned to the ARP Controllers in Global Mode.

n : When in Program/Combination mode, Global channel.

When in Sequencer mode, current selected track's channel.

2-2 SYSTEM COMMON MESSAGES

[H] :Hex, [D] :Decimal

Status	Second	Third	Description (Use for)	
[Hex]	[H] [D]	[H] [D]		
F2	ss (ss)	tt (tt)	Song Position Pointer (Location)	*6
			ss : Least significant [LSB]	
			tt : Most significant [MSB]	
F3	ss (ss)		Song Select	
			ss : Song(0-127) No.	

Receive when in Sequencer mode.

2-3 SYSTEM REALTIME MESSAGES

Status[Hex]	Description (Use for.....)	
F8	Timing Clock (Tempo, AMS & FX Dmod Src)	*5
FA	Start (Seq Start & Arpeggiator Control)	*6
FB	Continue (Seq Continue start & Arpeggiator Control)	*6
FC	Stop (Seq Stop & Arpeggiator Control)	*6
FE	Active Sensing (MIDI Connect check)	

*5 Receive when MIDI Clock in Global mode is External MIDI.

*6 Receive when MIDI Clock in Global mode is External MIDI
and Receive Rcv ExtrRTC(Ext. Realtime Commands) in Global mode is on.

IMPORTANT NOTICE TO CONSUMERS

This product has been manufactured according to strict specifications and voltage requirements that are applicable in the country in which it is intended that this product should be used. If you have purchased this product via the internet, through mail order, and/or via a telephone sale, you must verify that this product is intended to be used in the country in which you reside.

WARNING: Use of this product in any country other than that for which it is intended could be dangerous and could invalidate the manufacturer's or distributor's warranty.

Please also retain your receipt as proof of purchase otherwise your product may be disqualified from the manufacturer's or distributor's warranty.

KORG KORG INC.

4015-2 Yanokuchi, Inagi-city, Tokyo 206-0812 Japan