

# YD-702J-6637J

## Product Specifications

SUPER SLIM 3.5 FLOPPY DISK DRIVE

12.7mm HEIGHT

2.0/1.6/1.0 MB 3MODE TYPE



Revisions

Month/ Year	Revision	Reason for Revision	Revised Pages
Oct., 1999	Rev. A	1 <sup>st</sup> edition	
Jan., 2000	Rev. A1	Delete optional connector (NON-ZIF TYPE)	P11
Apr., 2000	Rev. A2	Screw fastening torque change	P13
Jul., 2001	Rev. A3	Additional of specification (Non operating shock)	P3,4
Aug, 2003	Rev. A4	Added to comments on restrictions of liability and high safety use. Drawing adjustment.	P2,12

- Reproduction in whole or in part of this software and instruction manual, and the leasing of this software, without written permission of the licensor, are prohibited by the Copyright Law.
- This software is for use only with the designated equipment.
- The specification of this software is subject to change without notice for improvement.
- No liability whatsoever is assumed for any damages of any kind, including without limitation damages for loss of business or profits, other pecuniary loss, or third party claims, resulting from the use of the software included with this product.
- No liability whatsoever is assumed for any damages of any kind caused by misuse or by other equipment, or for trouble or damage incurred by unauthorized repair or alteration.
- Products with defects caused during manufacturing will gladly be replaced. No liability whatsoever is assumed for defects due to other causes.

For the usage of this product for High Safety use

This product is assumed for general uses, such as an object for general office work, personal and home use, and is not designed or manufactured supposing for High safety use. Make sure not to use this product without taking measures to ensure the safety required for the high safety use.

High Safety Use means the use that requires extremely high security (see examples), and that accompanies a serious danger for the life and body directly, if security cannot be ensured.

\*Nuclear control, airplane flight control, air traffic control, mass transportation operation control, life support, weapon launch control, etc.

This product specification is subject to change without notice.

This product specification describes the YD-702J series double-sided, 3.5 floppy disk drive for portable applications.

(1) In this manual, the term “drive” refers to the YD-702J series double-sided, 3.5 floppy disk drive. The term “disk” refers to the 3.5 floppy disk.

- This specification may be revised without prior notice.  
Make sure to check the revision number when placing an order.
- Unauthorized duplication of this document is prohibited.

## Chapter 1. Introduction

These specifications pertain to the YD-702J series of 3.5", super slim, 5-volt single power supply, double-sided micro floppy disk drives.

The YD-702J series has been designed for 3.5 (90mm) floppy disk.

### *1. Super-sliminess*

With a 12.7mm height and a weight of 158g, the YD-702J drive is approximately half the size and weight of current 3.5 floppy disk drives (compare with Y-E DATA's YD-702D).

### *2. Low Power Consumption*

A standard power consumption of 1.15W during operation and 15mW during standby allows for battery-driven operation.

### *3. High Performance*

A direct drive brush less motor is used to guarantee high performance.

### *4. Shock Resistance*

Shock-absorbing teeth built directly into the head carriage assembly have raised shock resistance to  $980.7\text{m/s}^2$  {100G}(11ms half-sine wave) and  $2157.5\text{m/s}^2$  {220G}(2ms half-sine wave).

Chapter 2. Product Specifications

2.1 Performance

Item	2.0MB Mode	1.6MB Mode	1.0MB Mode
Capacity			
● Unformatted	2.0Mbytes	1.6Mbytes	1.0Mbytes
● Formatted			
1)Sectors/Track		26: 1025.0kBytes	16: 655.4kBytes
2)Sectors/Track	18: 1474.6kBytes	15: 1182.7kBytes	9: 737.3kBytes
3)Sectors/Track		8: 1261.6kBytes	5: 819.2kBytes
Recording Density (bits/mm){BPI}	686.4{17434}	558.4{14184}	343.2{8717}
Track Density (tracks/mm){TPI}	5.315{135}	5.315{135}	5.315{135}
Cylinders	80 Cylinders	77 Cylinders	80 Cylinders
Tracks	160 Tracks	154 Tracks	160 Tracks
Encoding Method	MFM	MFM	MFM
Rotational Speed (min <sup>-1</sup> ){RPM}	300	360	300
Transfer Rate	500 kbits/s	500 kbits/s	250 kbits/s
Latency(Average)	100 ms	83 ms	100 ms
Access Time			
● Average	94 ms	91 ms	94 ms
● Track to Track	3 ms	3 ms	3 ms
● Settling Time	15 ms	15 ms	15 ms
● Turn Around Time	4 ms	4 ms	4 ms
Motor Start Time	0.5sec	0.5 ms	0.5sec

Table 2.1 Performance

2.2 Physical Specifications

Signal Connector	FFC Connector 1mm pitch, 26pin Including DC power line Refer to figure 4.2
DC Power Requirements	Refer to Table 3.8.
Power Consumption	1.15W TYP
Environment	
● Operating	
Temperature	5°C to 50°C (note 1)
Relative Humidity	20% to 80%
Maximum Wet Bulb	29°C
Vibration	9.8m/s <sup>2</sup> {1G}(10-200Hz) 4.9m/s <sup>2</sup> {0.5G}(200-500Hz)
Shock	58.8m/s <sup>2</sup> {6G} (11ms half-sine wave)
● Non operating	
Temperature storage	-40°C to 60°C
Transportation	-40°C to 65°C
Relative Humidity	No condensation
Vibration	19.6m/s <sup>2</sup> {2G}(10-500Hz)
Shock	980.7m/s <sup>2</sup> {100G} (11ms half-sine wave) 2157.5m/s <sup>2</sup> {220G} (2ms half-sine wave)
Mechanical Dimensions	
Width	96.0mm
Height	12.7mm
Depth	130mm
Weight	158g(TYP)
Safety Approvals	UL, CSA, TÜV, CE
Mounting Recommendations	See figure 5.2

Table 2.2 Physical Specifications

Notes:

1. Depending on the mounting orientation, drive performance may be affected at maximum temperatures. Please mount the drive to ensure that the temperature at the diskette jacket does not exceed that outlined in the media specifications.

2.3 Reliability and Maintenance

MTBF	30,000POH
PM*	None
MTTR	30 minutes
Component Life	5years or 20,000POH
Error Rates	
●Soft Errors	1 per 10 <sup>9</sup> bits read
●Hard Errors	1 per 10 <sup>12</sup> bits read
●Seek Errors	1 per 10 <sup>6</sup> seek operations

Table 2.3 Reliability

\* Preventive maintenance

Note: Non-operating shock and vibration values are the same as above with or without disk in the drive.

**Chapter 3. Interface**

Refer to figure 3.6 for all interface connections.

**3.1 Interface Signals**

**3.1.1 Input signals**

The YD-702J has input lines as shown below. All lines are active (true) when “Low”

(1)	DRIVE SELECT 0
(2)	MOTOR ON
(3)	DIRECTION SELECT
(4)	STEP
(5)	WRITE DATA
(6)	WRITE GATE
(7)	SIDE ONE SELECT
(8)	MODE SELECT

Table 3.1 Input Signals

**3.1.1.1 DRIVE SELECT 0**

With the exception of the MOTOR ON signal, all the interface signals become valid when the DRIVE SELECT signal is set to low level.

**3.1.1.2 MOTOR ON**

When “MOTOR ON” is “Low” and a disk is inserted into the drive, the spindle motor will start. The spindle motor operates regardless of “DRIVE SELECT”. However if the disk is removed, the spindle motor will immediately stop.

**3.1.1.3 DIRECTION SELECT**

This line determines the direction of read/write heads movement when the “STEP” line is pulsed.

“HIGH” level	Out(away from the center of the disk)
“LOW” level	In(toward the center of the disk)

Table 3.2. DIRECTION SELECT

Any change on this line must be done at least 1 usec.before the leading edge of the step pulse, and at least 1 usec. after the trailing edge of the step pulse.

Refer to figure 8 for the timing information.

**3.1.1.4 STEP**

This signal moves the read/ write heads in the direction defined by the “DIRECTION SELECT” signal.

The access motion is initiated on each “LOW” to “HIGH” level transition, in other words, with the trailing edge of the signal pulse. In a seek operation, an 18 ms delay following the last “STEP” pulse is required for settling time before any read/write operation can be initiated.

After direction switching, minimum 4 ms delay is required before initiating the next seek operation.

Change of step pulse period during seek operation is not recommended for seek error.

Refer to figure 1 for timing.

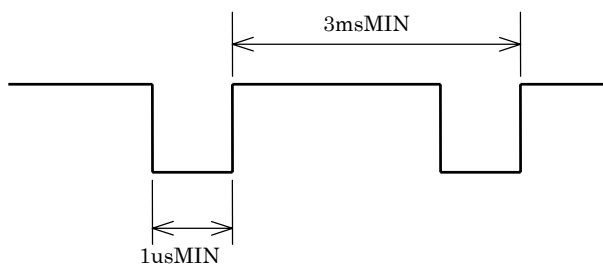
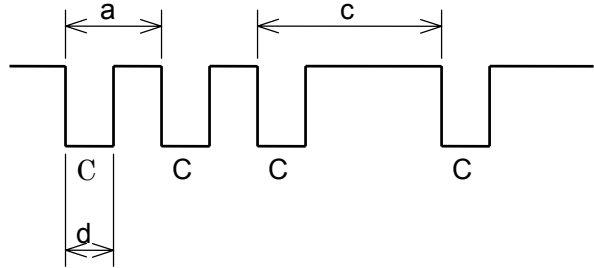

Fig.3.1 Step

**3.1.1.5 WRITE DATA**

The “WRITE DATA” line provides the data to be written on the disk. Each transition from “High” to “Low” on the line causes the current through the read/ write heads to be reversed, thereby writing a data bit. This line is enabled when the “WRITE GATE” line is “Low” active. Refer to figures 3.2 and 3.11 for the timing information.

**FM Recording**



**MFM Recording**

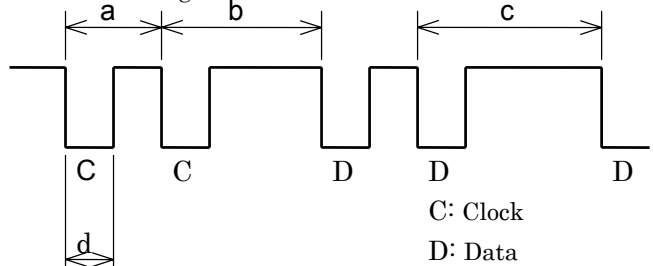

Fig.3.2 WRITE DATA

Notes:

1.

	2.0 / 1.6 MB	1.0MB
a	2.00us±10ns	4.00us±20ns
b	3.00us±15ns	6.00us±30ns
c	4.00us±20ns	8.00us±40ns
d	150-1100ns	150-2100ns

2. All timings indicate the values without write pre-compensation.

3. The write precompensation value in 2.0MB is 125 ns on all tracks, and in other capacities as below:

Capacity	2.0MB	1.6MB	1.0MB
WPC value	125 ns	0-125 ns	0-250 ns

4. The recommended condition during read operation is to not input “WRITE DATA”.

**3.1.1.6 WRITE GATE**

A “Low” active level on this line allows “WRITE DATA” to be written on the disk. A “High” inactive level enables read data logic and stepping logic. Refer to figure 3.11 for the timing information. Activation of “DRIVE SELECT” and “MOTOR ON”, changing “SIDE ONE SELECT” and/or activation of “STEP” must be delayed at least the values indicated (see the following READ RECOVERY TIME table 3.3) following deactivation of “WRITE GATE” because the erase heads remain active during this period.

Capacity	2.0MB	1.6MB	1.0MB
RRT MIN	650 us	590us	1000 us

Table 3.3 Read Recovery Time

### 3.1.1.7 SIDE ONE SELECT

This line defines which side of a two sided disk will be used for reading or writing. A “High” level on this line selects the read/write head on side 0 surface on the disk. A “Low” level on this line selects the read/write head on the side 1 surface. When switching heads, a 100 usec. delay is required before any read or write operation can be initiated.

### 3.1.1.8 MODE SELECT

The YD-702J series has an internal circuit that performs the switching of the drive’s three (2.0/1.6/1.0MB) capacity modes.

Please refer to below.

Capacity Mode	Switching Method	Specifications
3 Mode (2.0/1.6/1.0MB)	Automatic Switching with Interface Signal	The drive is in 1.0MB mode with double density media and independent of the “MODE SELECT” signal (J1-13). If high-density media is inserted with the “MODE SELECT” signal is “LOW” when the drive is in 1.6MB mode. If high-density media is inserted with the “MODE SELECT” signal is “HIGH” when the drive is in 2.0MB mode.

Table 3.4 MODE SELECT

- Notes:
- (1) To switch capacity mode is effected by a signal level on the “MODE SELECT” signal.
  - (2) It is necessary to wait 0.5 sec. before executing a read/write operation after motor revolution speed is switched for capacity mode change. “READ DATA”, “INDEX”, signals are inhibited to output during this term.

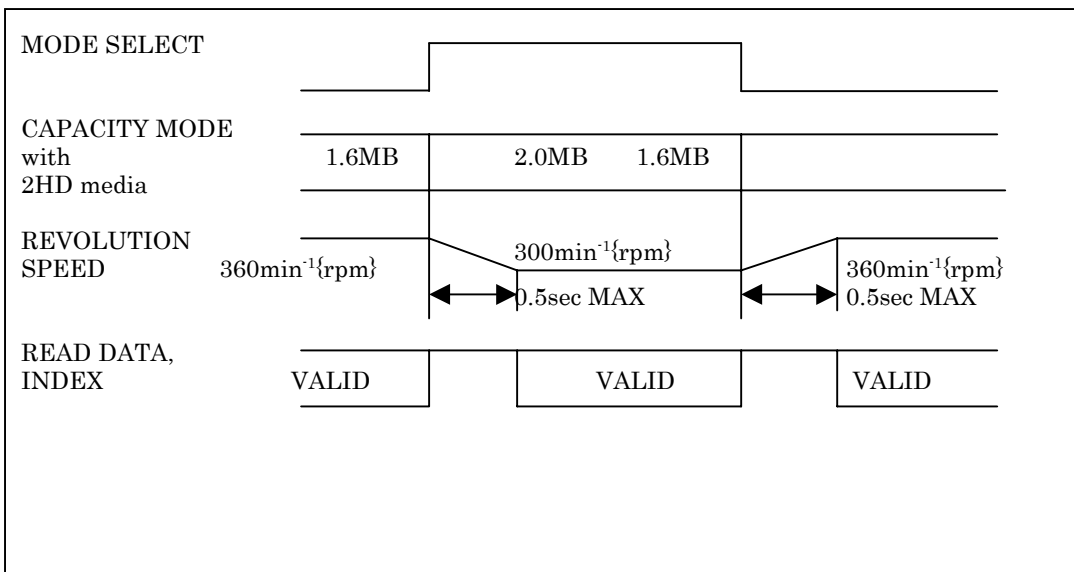

Fig.3.3 Capacity Mode Switching

### 3.1.2 Output signals

Output signals are shown below. All lines are active when the "DRIVE SELECT" signal is "Low".

- |                  |
|------------------|
| (1)TRACK 00      |
| (2)INDEX         |
| (3)HD(High: HD)  |
| (4)WRITE PROTECT |
| (5)READ DATA     |
| (6)READY         |
| (7)DISK CHANGE   |

Table 3.5 Output Signals

#### 3.1.2.1 TRACK 00

A "Low" active level on this line indicates that the read/write heads are positioned at track 00(the outermost track). The line goes "High" inactive when the heads are positioned elsewhere. Refer to Fig.3.8 for the timing information.

#### 3.1.2.2 INDEX

One index pulse is output at each revolution of the disk when the drive is ready to read/write. Normally this signal is at "High" level, and makes the transition to "Low" level when a pulse is generated. This signal is inhibited to output during seek and not ready. The controller should detect "INDEX" with the leading edge of the transition rather than with the signal level.

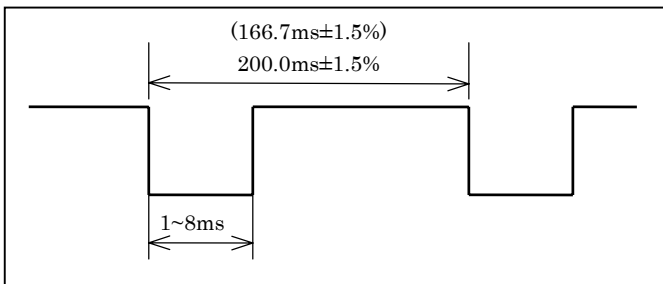

Fig.3.4 INDEX

#### 3.1.2.3 WRITE PROTECT

A "Low" active level on this line indicates that a disk with a write protect notch is loaded. During normal operation the drive will prevent writing when a protected disk has been inserted.

#### 3.1.2.4 READ DATA

This line provides the "READ DATA"(clock and data together) as detected by the drive electronics. Normally this signal is "High" level and becomes "Low" level for each flux reversal. The transition from "High" to "Low" level should be used for separation of data bits from read data. This signal is inhibited to output during seek and not ready. The different value between the leading edge of each bit pulse and its nominal position is below note 2. Timing characteristics are shown in figure 3.10.

##### FM Recording

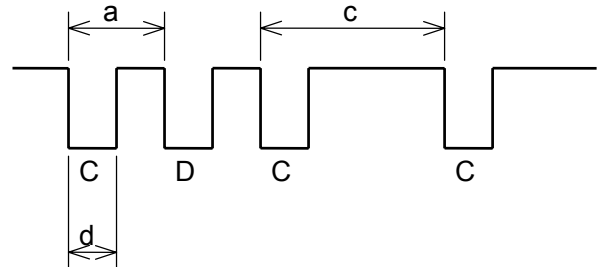

##### MFM Recording

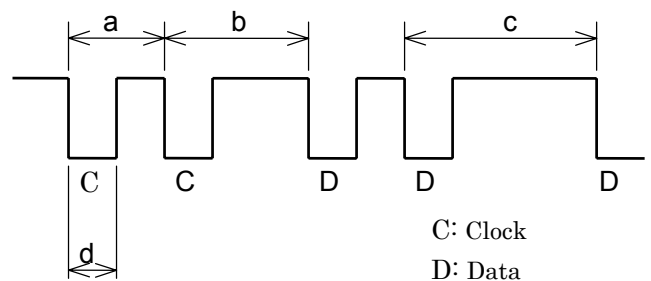

Fig.3.5 READ DATA

Notes:

1.

	2.0/1.6MB	1.0MB
a	2.00us NOM	4.00us NOM.
b	3.00us NOM.	6.00us NOM.
c	4.00us NOM.	8.00us NOM.
d	150-1100ns	150-2100ns

2.

Capacity	2.0/1.6MB	1.0MB
Difference	±350ns	±700ns

#### 3.1.2.5 DISK CHANGE

The "DISK CHANGE" signal indicates that the disk has been removed. This signal becomes "Low" after power has been applied to the drive and the disk has been removed. This signal remains active until the following conditions have satisfied:

- (1) A disk is correctly inserted;
- (2) A drive has been selected and a step pulse has been applied.

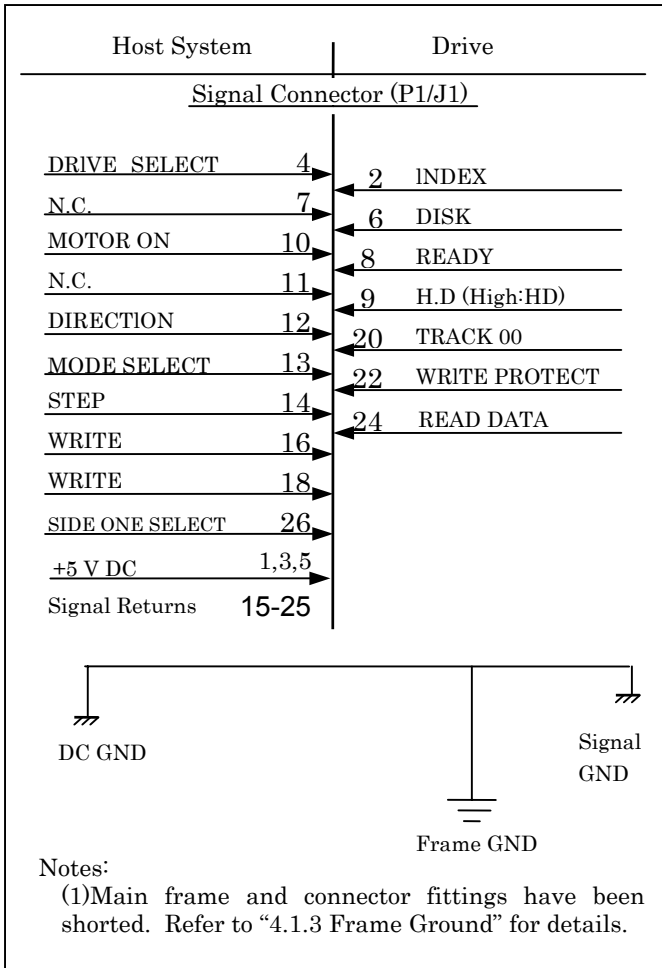

Fig.3.6 Interface Connection

### 3.1.3 Interface Circuits

The YD-702J series uses open collector drivers as output line drivers, and TTL level gates as input line receivers. The input of each receiver is terminated in 20 k ohms pulled up to Vcc (+5V). Input/output circuit electrical specifications are as shown below.

Inactive	"High" Level	2.0 V to Vcc
Active	"Low" Level	0 to 0.8 V
Input Impedance		20 k ohms pulled up to Vcc

Table 3.6 Input Circuit Electrical Specifications

Inactive	"High" Level	Open
Active	"Low" Level	0 to 0.4V Sink current: 6mA MAX

Table 3.7 Output Circuit Electrical Specifications

The illustration below shows the recommended controller interface circuit.

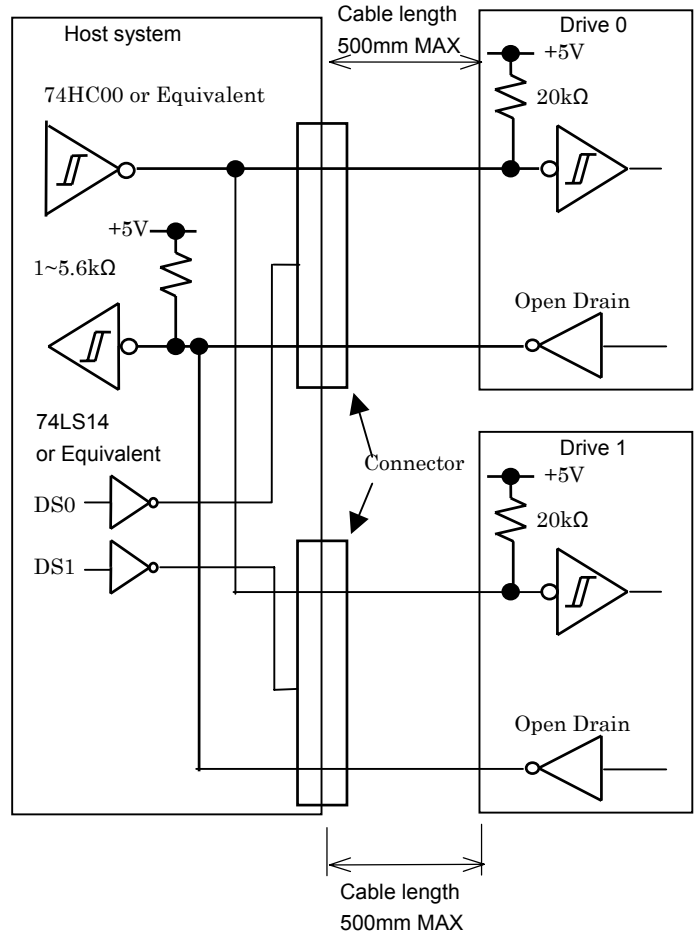

Fig 3.7 Interface Circuit

To connect the drives to the host system via a daisy chain, an FFC (Flexible Flat Cable) connection cable must be used. Refer to section 4.1.2 for this cable's specifications. Also, because an FFC cable (as opposed to a conventional flat cable) is used, 2 FFC connectors are required in the host system.

Caution: In the case where multiple drivers are connected in a daisy chain, it is forbidden to leave any drive unpowered.

Each drive should receive power from the host system.

#### 3.1.3.2 Host System Terminal Resistor

Because the line driver of the drive is an open collector output, please use a terminal resistor (1k~5.6kΩ) on the host system side.



### 3.1.4 Timing

#### 3.1.4.1 Track 00 Timing

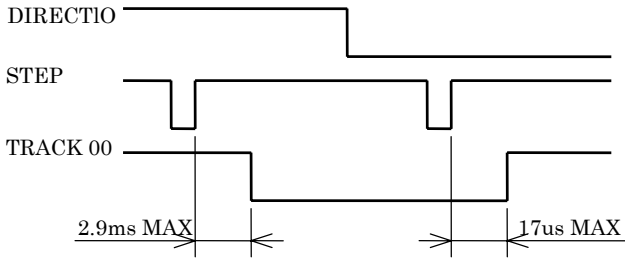

Fig.3.8 Track 00 Timing

#### 3.1.4.2 Seek Timing

In order to reduce the peak current, we recommended that no seek operation be performed for 0.2 seconds after motor start. Figure 3.9 shows the preferred timing.

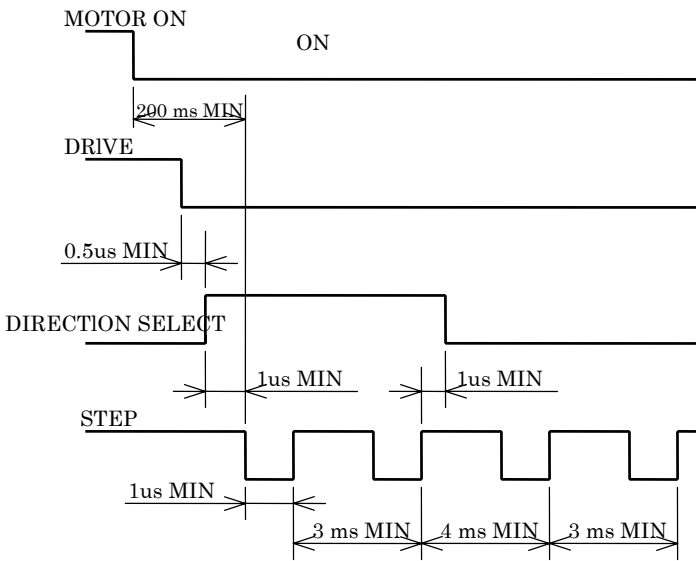
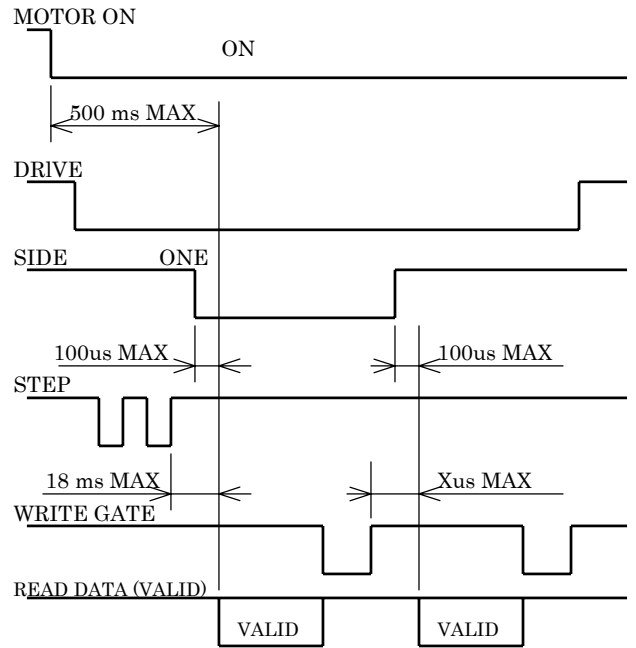

Fig.3.9 Seek Timing

#### 3.1.4.3 Read Timing



Note:

Capacity	2.0MB	1.6MB	1.0MB
X us MIN	650 us	590 us	1000 us

Fig.3.10 Read Timing

#### 3.1.4.4 Write Timing

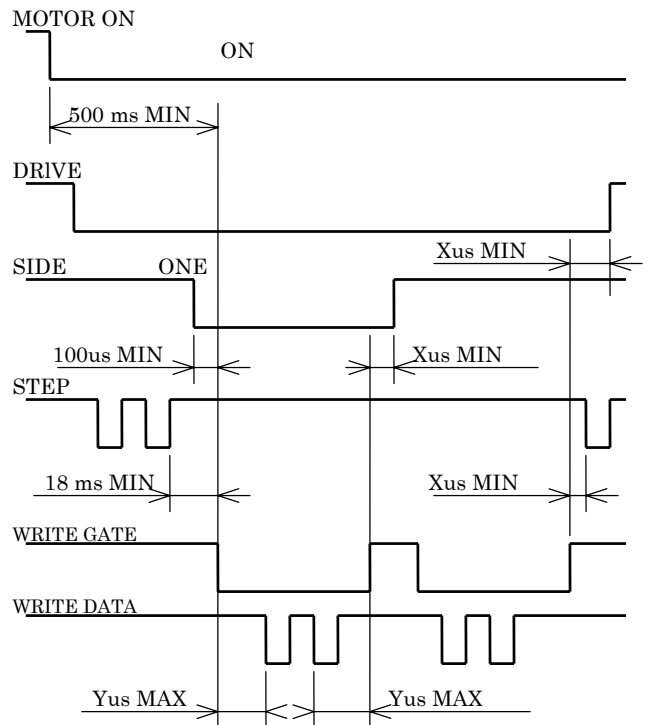

Note:

Capacity	2.0MB	1.6MB	1.0MB
X us MIN	650 us	590 us	1000 us
Y us MAX	4 us	4 us	8 us

Fig.3.11 Write Timing

### 3.2 Power Interface

#### 3.2.1 Power Supply Specifications

Voltage	Operating Mode	TYP(mA)	MAX(mA)
+5VDC ±10% (Ripple: 100 mVp-p MAX)	Stand by	3	5
	Read	230	350
	Write	230	350
	Seek	550	750
	Peak	Motor Start	650
	Seek	550	830

Table 3.8 Power Supply Specifications

Notes:

- (1) "MAX" values reflect measurement taken at maximum voltage; "TYP" values reflect measurement taken at nominal voltage.
- (2) "Standby" refers to the state where all input signals are inactive.
- (3) "Read" and "Write" refer to the state where the heads are at track 40, side 1 and the In Use Lamp is on.
- (4) "Seek" refers to the average current with the drive continuously seeking at 3 ms and the spindle motor rotating.
- (5) When the spindle motor starts, "Motor Start" current will continue for approximately 200 ms.
- (6) Peak current of "Seek" refers to the state of maximum seek current when the spindle motor is rotating and the heads are stepping at 6 ms.

The above specifications must be met when voltages are measured at power connector on PWB.

#### 3.2.2 Current Waveform

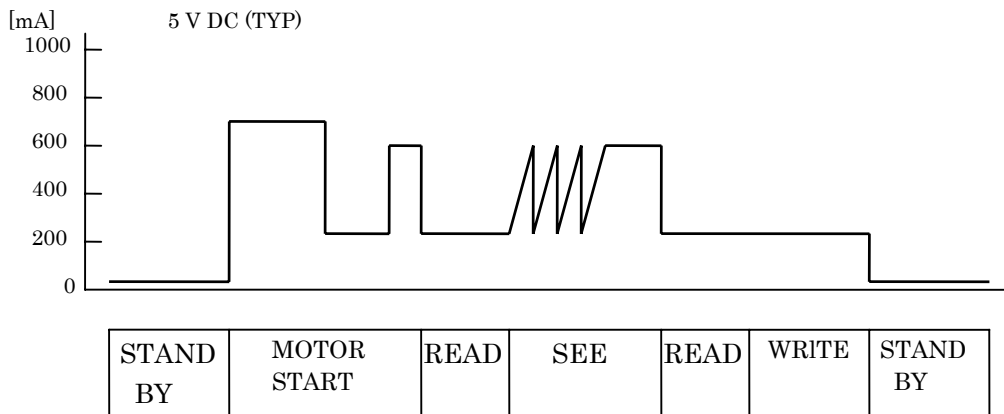

Fig.3.12 Current Waveform

## Chapter 4. Physical Interface

This drive is connected to the host system by one type of connectors.

The cable connections are illustrated in figure

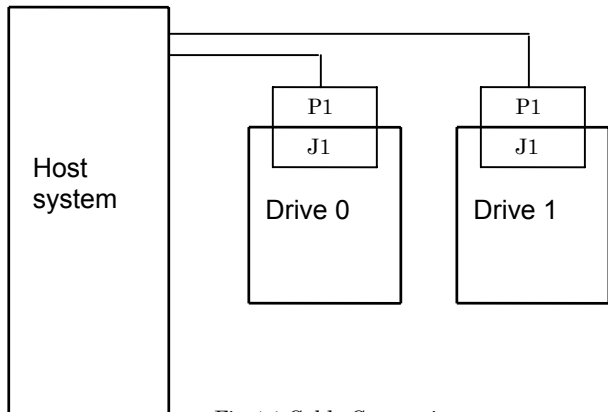

Fig 4.1 Cable Connections

### 4.1 Signal Connector and cable (J1/P1)

#### 4.1.1 J1 Signal Connector

The J1 Signal connector is 26pin FFC connector located at the rear of the drive.

#### Standard:

ZIF TYPE (SMK Model CFP5126-0501 or equivalent)

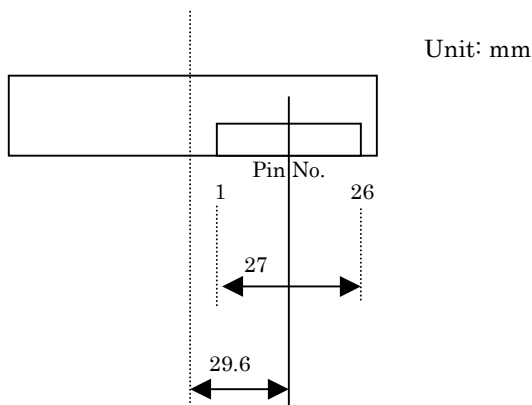

Fig 4.2 J1 Signal Connector Dimensions

#### 4.1.2 P1 Cable

A P1 cable connector is used to connect the J1 signal connector to the system interface.

#### Recommended Parts

- FFC: • Sumitomo Electric Industries LTD's "sumi" card SMCD-26  
• Eikura Communication's ET-C100-26

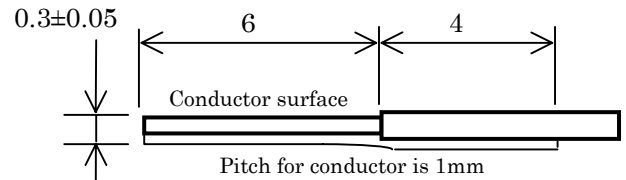

Fig 4.3 FFC Dimensions for FDD side

#### 4.1.3 Frame Ground

The internal circuit ground on the PWB has been connected with the frame for shielding purposes. The frame ground of the system will be connected to the signal ground through the drive when the drive is installed into the system.

The frame ground and signal ground of the system have to be connected except the drive.

Otherwise the drive ought to be floated from the frame ground of the system.

### 4.2 Connector Pin Assignments

#### 4.2.1. Signal Connector Pin Assignments

Signal Pin#	Signal name
2	INDEX
4	DRIVE SELECT 0
6	DISK CHANGE
7	N.C.
8	READY
9	HD (High: HD)
10	MOTOR ON
11	N.C.
12	DIRECTION SELECT
13	MODE SELECT
14	STEP
16	WRITE DATA
18	WRITE GATE
20	TRACK 00
22	WRITE PROTECT
24	READ DATA
26	SIDE ONE SELECT
1,3,5	+5V
15~25	GND
(Odd No. pins)	

Table 4.1 Signal Connector Pins

#### 4.3 Terminators

All input lines on the drive are terminated with non-removable resistors of 20k ohms.

Chapter 5. Diagrams

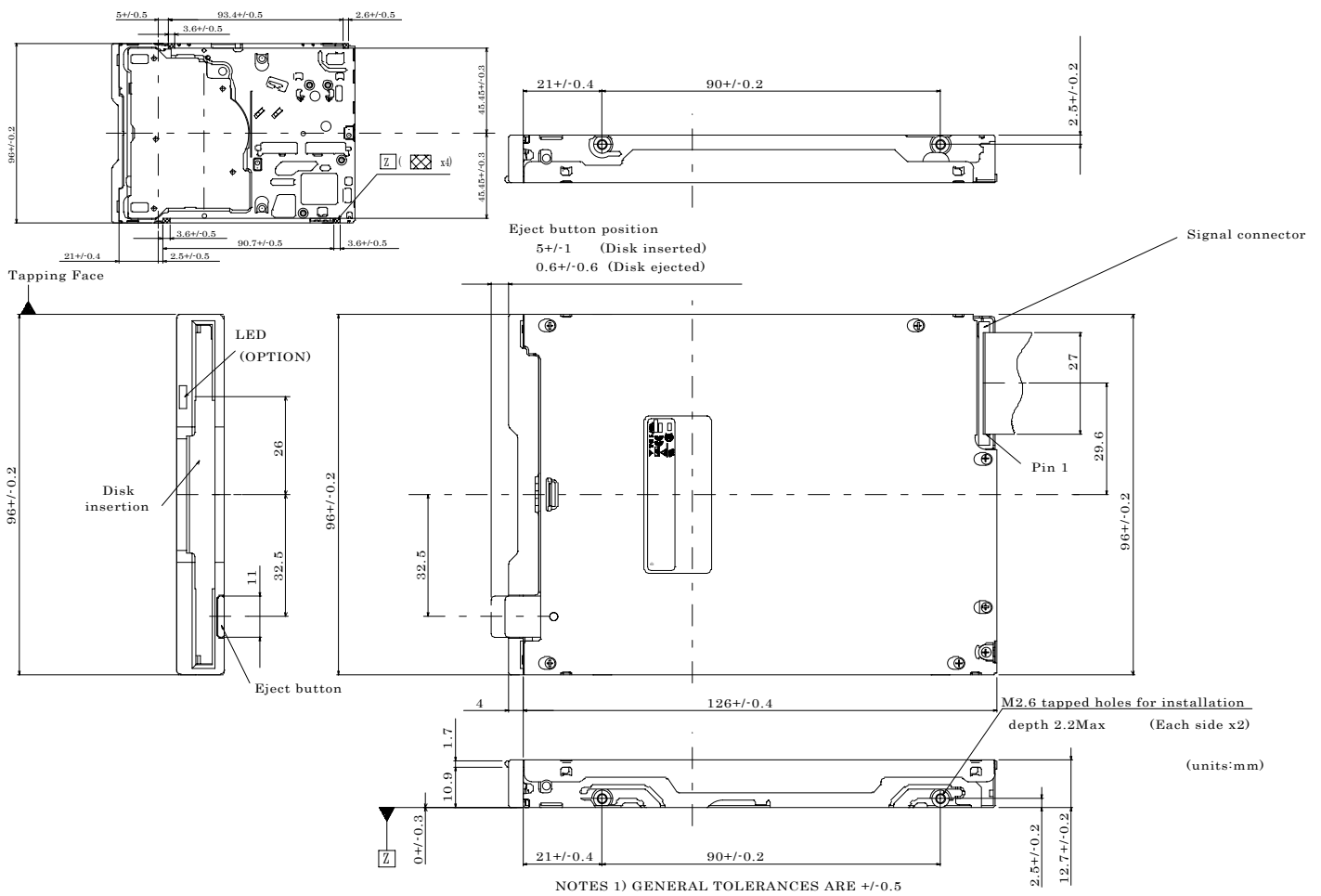
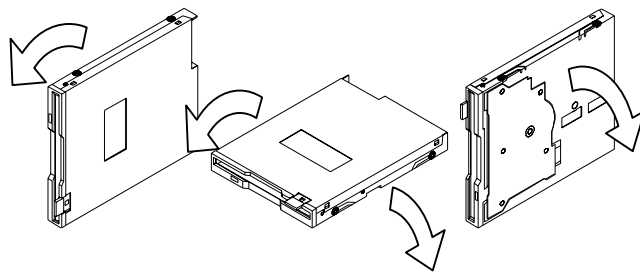

Fig.5.1 Mechanical Dimensions



Recommended angle of the drive when the drive is installed is less than +30 degrees.

Fig.5.2 Recommended Mounting

### 5.1 Caution on Mounting

- 1) Mounting screws should be tightened by  $0.2\text{Nm}$  ( $2\text{kgf}\cdot\text{cm}$ ) in torque.
- 2) Mounting bracket is recommended not to make contact with the drive except the mounting spots, and should not be designed that any portion on the drive except the mounting spots is pressed and/or crushed.
- 3) Recommended to fasten the drive at 3 mounting spots with screws (4 spots available).
- 4) Mounting bracket should be provided structure to absorb strain.
- 5) The drive should be separated or shielded from noise sources. Do not strain the drive. Do not install the drive in large electromagnetic fields. Otherwise, failure may result.

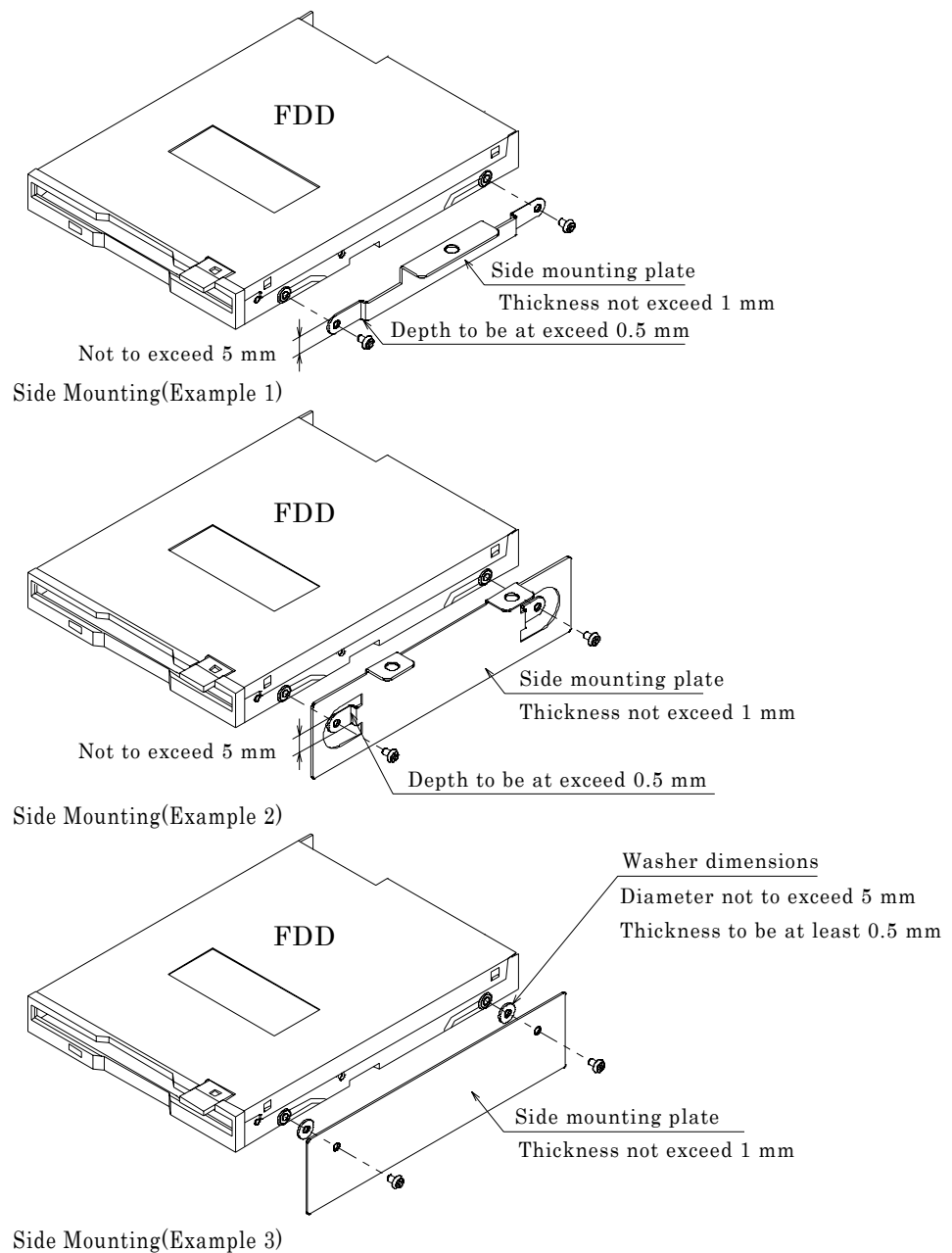

Fig.5.3 Caution on Mounting

## 5.2 Caution on handling

- 1) Strong vibration and shock can damage the drive. It may cause an error. Do not use or store the drive under such conditions.
- 2) We recommend handling the drive on side frame, portion of mounting spots, of the drive as well as possible. If you handle like pressing the top or the bottom of the drive, it may cause damage of heads and PWB.
- 3) Do not disassemble the drive by yourself because of an adjusted product. If you do so, we can not assure you of adjusted accuracy.

## Chapter 6. Other Functional Characteristics

### 6.1 Standby Mode

The YD-702J includes standby mode to reduce the load on the host system power supply when the drive is not actually in use. When the spindle motor stops, power to the read/write and spindle motor control systems is cut off, and power to the stepper is cut off when the stepper is not seeking.

As a result of this built in power conservation, when all the interface input signals are inactive, typical drive power consumption is 15mW.

### 6.2 In Use

The IN USE lamp will turn on when DRIVE SELECT is at low level and turn off when it is high.

### 6.3 Mask Function

“READ DATA” and “INDEX” signals are inhibited to output during seek (includes 18 ms MAX after the last step pulse) and not ready (500 ms MAX after motor start).

### 6.4 Automatic Motor On/Off

When the disk is inserted or removed, the spindle motor is controlled as follows:

- 1) When the disk is inserted, the spindle motor will start to rotate regardless of the “MOTOR ON” signal condition. The spindle motor will stop approximately 400 ms later if the “MOTOR ON” signal is not active, but will continue to rotate if it is active.
- 2) When the disk is removed, the spindle motor will stop.