

# Rackmount Mixers

## EURORACK PRO RX1602



### Professional Multi-Purpose 16-Input Ultra Low-Noise Line Mixer

- Extremely flexible keyboard and multi-purpose sub-mixer, multi-track monitoring mixer, level translator, FX return sub-mixer, etc.
- 16 balanced high-headroom line inputs for individual stereo or mono use of each section
- Ultra-low noise ULN design, highest possible headroom, ultra-transparent audio
- Dedicated balance and level controls plus +4/-10 level selection per channel
- Monitor/FX send control per section with global master send control for flexible monitoring, recording or effects applications
- Illuminated double-function "mute" button per section with additional "clip" indication provides comfortable input source/level information
- Monitor/FX signal assignable to phones output for added flexibility
- Highly accurate 2 x 7-segment LED level meters and individual level control for left and right main mix signal
- ¼" TRS main mix outputs plus easily accessible headphones output on the front panel with dedicated level control
- High-quality detented rotary controls for long-term reliability
- Shielded toroidal power transformer for lowest noise interference
- High-quality component components and exceptionally rugged construction ensure long life
- Conceived and designed by BEHRINGER Germany

The RX1602 is an incredibly versatile 16-channel line mixer that works perfectly for monitoring multi-track recording projects, sub-mixing multiple keyboards, sub-mixing samplers or mixing a small live set-up (for example, one keyboard and one microphone preamp). Its simple interface and intuitive features make it an invaluable addition to any recording enthusiast's or live performer's gear arsenal.

If you want to get technical, the RX1602 actually features a total of 24 channels, since the 8 stereo inputs can be used as 16 mono inputs. Any way you add it up, that's a lot of flexibility in one compact line mixer.

### We hate to call it a "Miracle Product," but...

Like a souped-up blender capable of liquefying golf balls and soda cans, the Eurorack Pro can mix just about anything into a delicious sonic puree. If you're a keyboardist with more keyboards than pairs of socks, the RX1602 can submix all your inputs into a single stereo signal, saving you valuable inputs on your main mixer.

Or, if you work frequently with hardware samplers in the studio, you can save yourself a ton of time by submixing your sampler's outputs with the RX1602. This mixer also makes monitoring your home recordings a breeze. Just hook it up to your PC equipped with recording software or a multi-track recorder to quickly and easily create a tasty monitor mix.

If a one-person band is more your style, the RX1602 provides the perfect solution for mixing down a mic preamp along with a keyboard. From there, you need only send a single signal to the house's main mixer.

### Channel With Care

The RX1602 comes equipped with all the necessary features to create the right mix for your sound. The 16 high-headroom inputs (8 stereo, 8 mono) can be used for individual line level instruments or component outputs. The ULN (Ultra Low-Noise) design's high headroom means you can run up to 16 HOT inputs without clipping – and at the same time be assured that there won't be any extra noise added by the mixer.

*Continued on next page*



# EURORACK PRO RX1602

Each channel has its own balance and level controls, as well as illuminated double-function "mute" buttons with "clip" LEDs to help you avoid distortion. You also get highly accurate dual 7-segment LED level meters and an individual level control for left and right main mix signals. For further flexibility, the Monitor/FX signal is assignable to headphones. It all adds up to transparent, crystal-clear audio performance.

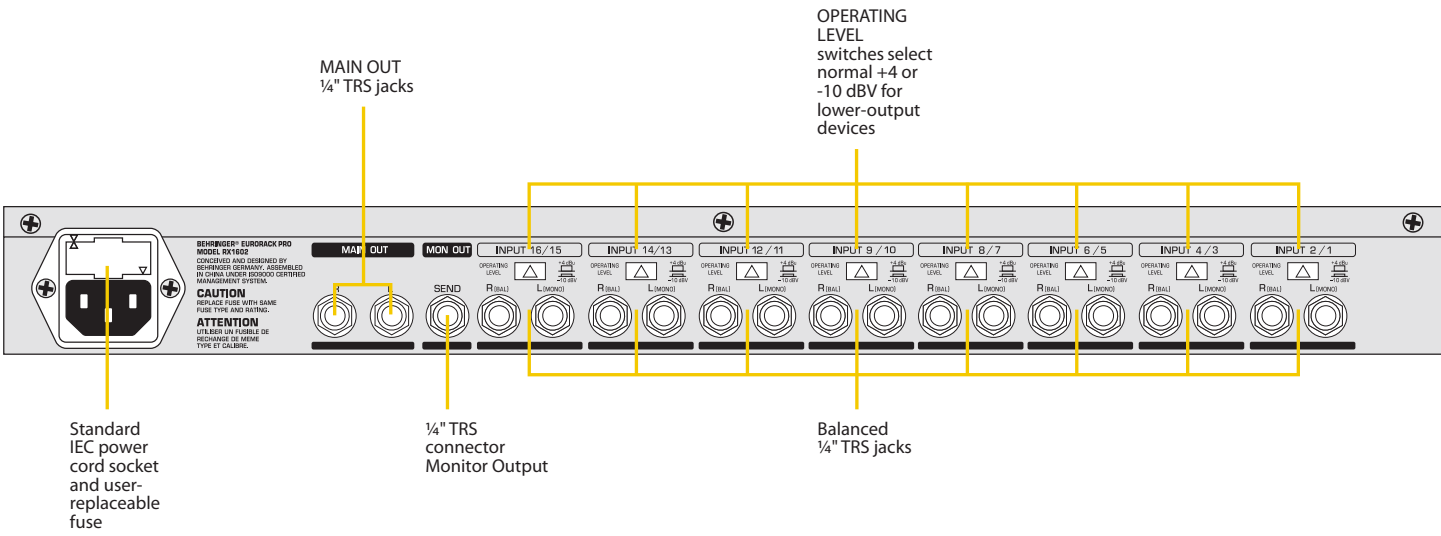
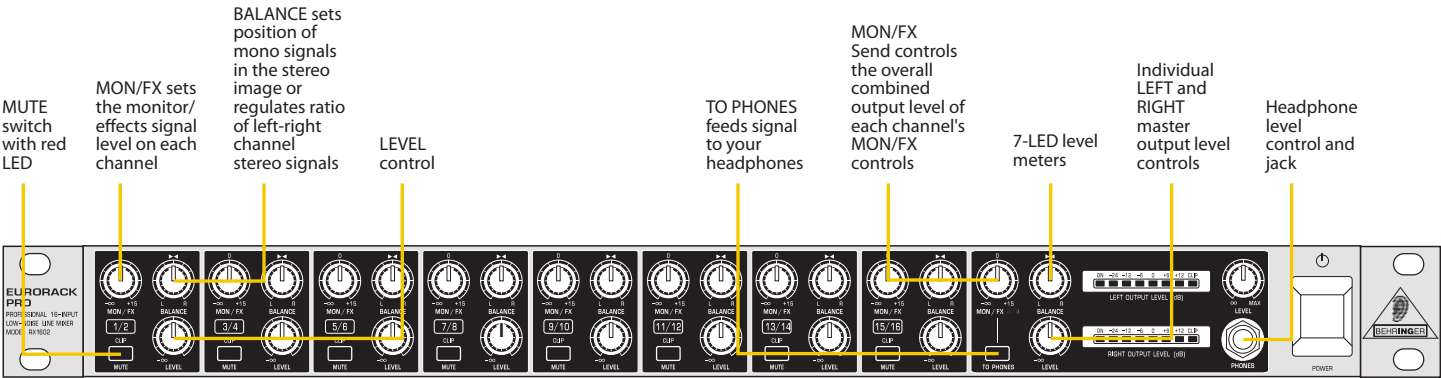

# EURORACK PRO RX1602

## Monitoring multi-track recorder

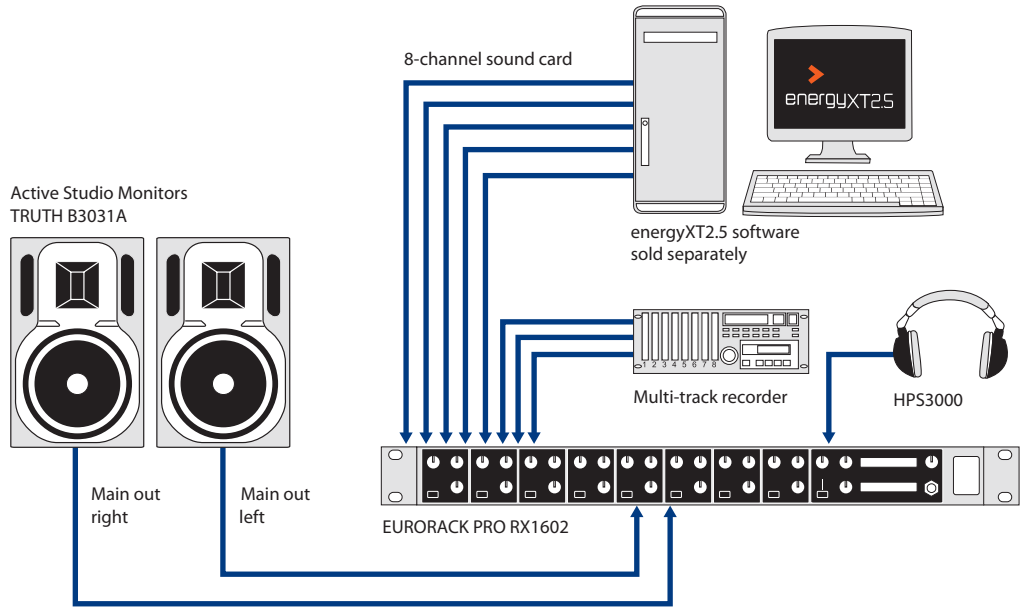

## Keyboards sub-mixer

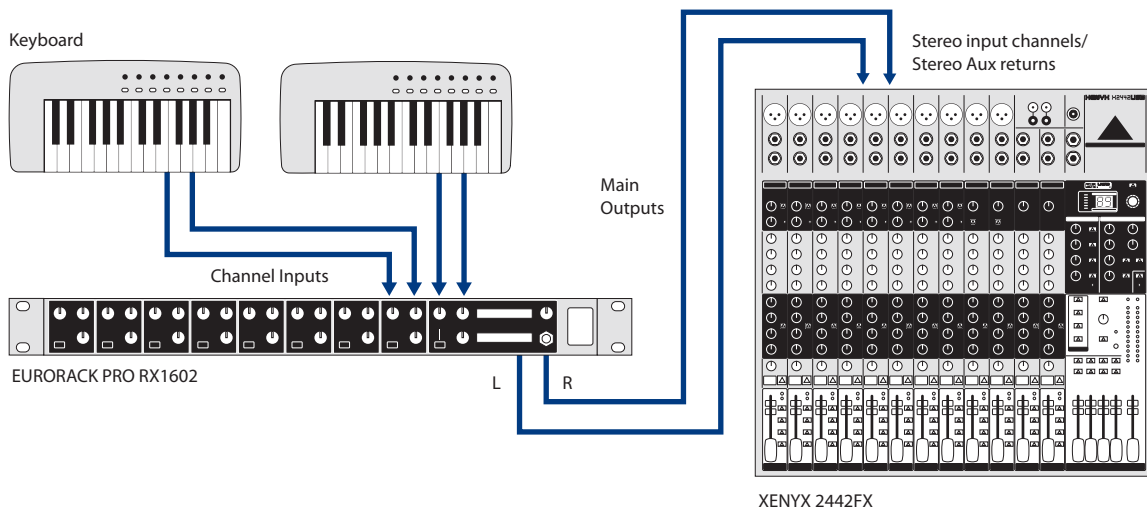

# EURORACK PRO RX1602

## Small Live setup

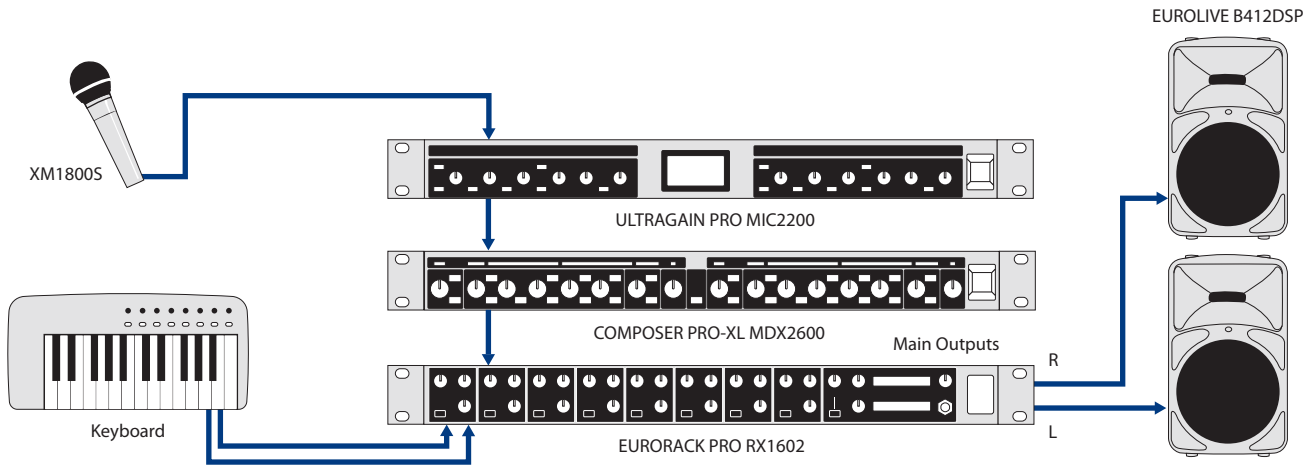

## Sub-mix with samplers

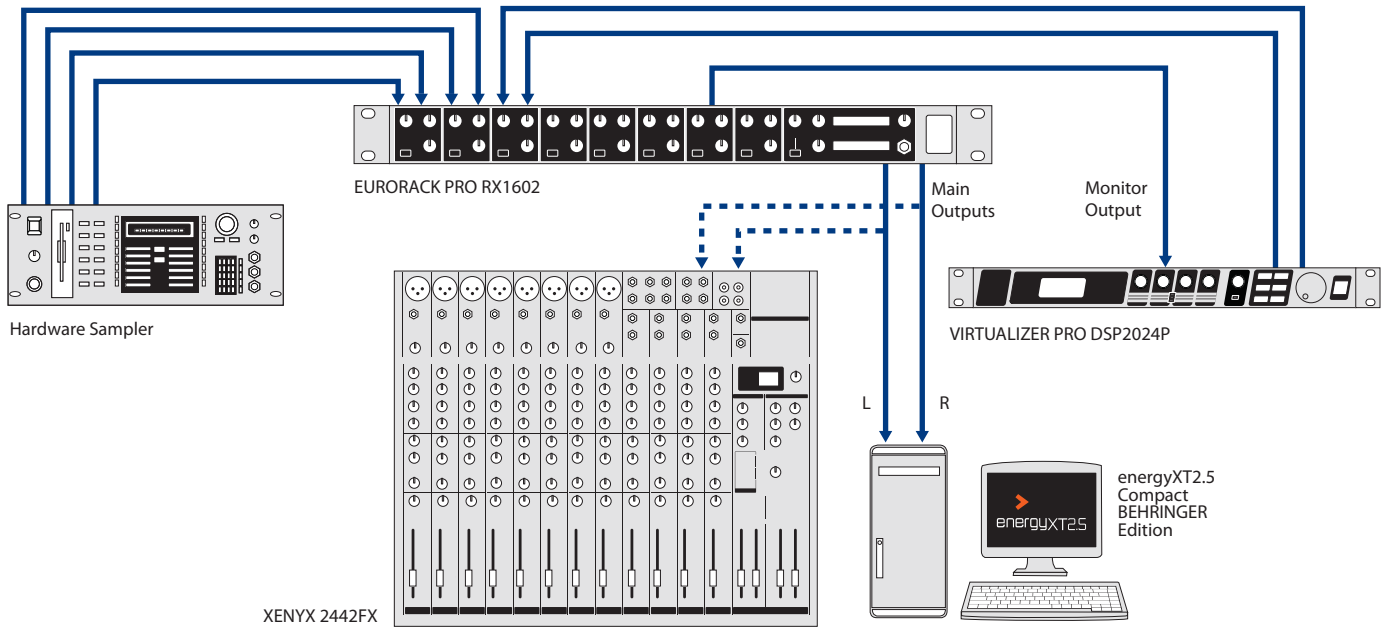

# EURORACK PRO RX1602

## AUDIO INPUTS

### INPUT L/R

Type	¼" TRS connector, electronically balanced
Impedance	approx. 20 kΩ balanced, 10 kΩ unbalanced
Gain Range	-∞ to +15 dB
Operating Level	variable, +4 dBu/-10 dBV (switchable)
Max. input level	+22 dBu
Common-mode rejection	typ. 44 dB CMRR @ 1kHz

## AUDIO OUTPUTS

### MAIN OUT L/R

Type	¼" TRS connector, unbalanced
Gain range	-∞ to +15 dB
Impedance	approx. 120 Ω
Max. output level	+22 dBu

## PHONES OUTPUT

Type	¼" TRS connector, stereo, unbalanced, mono
Minimum load impedance	100 Ω

## SYSTEM SPECIFICATIONS

Bandwidth	20 Hz – 20 kHz +/-0.2 dB
Frequency Range	20 Hz – 200 kHz +/-3 dB
Signal-to-noise ratio	<-97 dB
THD	0.0025% @ +4 dB input 1 kHz gain 1
Crosstalk	< -70 dB

## POWER SUPPLY

### Voltage

USA/Canada	120 V~, 60 Hz
Europe/U.K. Australia	230 V~, 50 Hz
Japan	100 V~, 50 – 60 Hz
General export model	120/230 V~, 50 – 60 Hz
Power consumption	max. 14 W
Fuse	100 – 120 V~: T 630 mA H 200 – 240 V~: T 315 mA H
Mains connection	Standard IEC connector

## DIMENSIONS/WEIGHT

Dimensions	approx. 1 ¾ x 19 x 8 ½" approx. 44.5 x 482.6 x 217 mm
Weight	approx. 5.07 lbs / 2.30 kg
Shipping Weight	approx. 7.83 lbs / 3.55 kg

Please note these specifications are preliminary and conceptual in nature, and as such are subject to change as product development progresses. This information is supplied for market research purposes only and is not to be made public in any manner. This document is solely the property of The MUSIC Group, or one of its subsidiaries, and must be surrendered upon request of the owner.

For service, support or more information contact the BEHRINGER location nearest you:

**Europe** Tel.: +49 2154 9206 4149  
Fax: +49 2154 9206 4199

**USA/Canada** Tel.: +1 425 672 0816  
Fax: +1 425 673 7647

**Singapore** Tel.: +65 6845 1800  
Fax: +65 6214 0275

**Australia** Tel.: +61 03 9877 7170  
Fax: +61 03 9877 7870

**Japan** Tel.: +81 3 5281 1180  
Fax: +81 3 5281 1181

©2010 Red Chip Company Ltd. Technical specifications and appearance subject to change without notice. The information contained herein is correct at the time of printing. All trademarks are the property of their respective owners. BEHRINGER accepts no liability for any loss which may be suffered by any person who relies either wholly or in part upon any description, photograph or statement contained herein. 985-10000-00291

behringer.com

